



M29W128FH M29W128FL

128 Mbit (8Mb x 16 or 16Mb x 8, Page, Uniform Block)
3V Supply Flash Memory

Feature summary

- Supply voltage
 - $V_{CC} = 2.7$ to $3.6V$ for Program, Erase and Read
 - $V_{PP} = 12V$ for Fast Program (optional)
- Asynchronous Random/Page Read
 - Page Width: 8 Words/16 Bytes
 - Page Access: 25, 30ns
 - Random Access: 60, 70ns
- Programming time
 - $10\mu s$ per Byte/Word (typical)
 - 4 Words / 8 Bytes Program
 - 32-Word (64-Bytes) Write Buffer
- 64 KByte (32 KWord) Uniform Blocks
- Program/ Erase Suspend and Resume Modes
 - Read from any Block during Program Suspend
 - Read and Program another Block during Erase Suspend
- Unlock Bypass Program
 - Faster Production/Batch Programming
- Common Flash Interface
 - 64 bit Security Code
- 100,000 Program/Erase cycles per block
- Low power consumption
 - Standby and Automatic Standby
- Hardware Block Protection
 - V_{PP}/\overline{WP} pin for fast program and write protect of the highest (M29W128FH) or lowest block (M29W128FL)
- Extended Memory Block:
Extra block used as security block or to store additional information

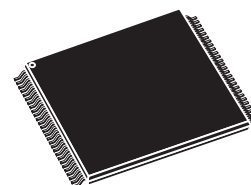

TSOP56 (N)
14 x 20mm

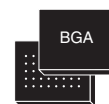

TBGA64 (ZA)
10 x 13mm

- Electronic Signature
 - Manufacturer Code: 0020h
 - Device Code:
M29W128FH: 227Eh + 2212h + 228Ah
M29W128FL: 227Eh + 2212h + 228Bh
- ECOPACK[®] packages

Contents

1	Summary description	7
2	Signal descriptions	12
2.1	Address Inputs (A0-A22)	12
2.2	Data Inputs/Outputs (DQ0-DQ7)	12
2.3	Data Inputs/Outputs (DQ8-DQ14)	12
2.4	Data Input/Output or Address Input (DQ15A-1)	12
2.5	Chip Enable (E)	12
2.6	Output Enable (G)	12
2.7	Write Enable (W)	13
2.8	V _{PP} /Write Protect (V _{PP} /WP)	13
2.9	Reset/Block Temporary Unprotect (RP)	14
2.10	Ready/Busy Output (RB)	14
2.11	Byte/Word Organization Select (BYTE)	14
2.12	V _{CC} supply voltage (2.7V to 3.6V)	14
2.13	V _{SS} ground	15
3	Bus operations	16
3.1	Bus Read	16
3.2	Bus Write	16
3.3	Output Disable	16
3.4	Standby	16
3.5	Automatic Standby	17
3.6	Special Bus operations	17
3.6.1	Read Electronic Signature	17
3.6.2	Verify Extended Memory Block Protection Indicator	17
3.6.3	Verify Block Protection Status	17
3.6.4	Hardware Block Protect	17
3.6.5	Temporary Unprotect of high voltage Protected Blocks	18
4	Hardware protection	21
4.1	Write Protect	21

4.2	Temporary Block Unprotect	21
5	Command interface	22
5.1	Standard commands	22
5.1.1	Read/Reset command	22
5.1.2	Auto Select command	22
5.1.3	Read CFI Query command	22
5.1.4	Chip Erase command	23
5.1.5	Block Erase command	23
5.1.6	Erase Suspend command	24
5.1.7	Erase Resume command	24
5.1.8	Program Suspend command	24
5.1.9	Program Resume command	25
5.1.10	Program command	25
5.2	Fast Program commands	28
5.2.1	Write to Buffer and Program command	28
5.2.2	Write to Buffer and Program Confirm command	29
5.2.3	Write to Buffer and Program Abort and Reset command	29
5.2.4	Double Word Program command	29
5.2.5	Quadruple Word Program command	30
5.2.6	Double Byte Program command	30
5.2.7	Quadruple Byte Program command	30
5.2.8	Octuple Byte Program command	31
5.2.9	Unlock Bypass command	31
5.2.10	Unlock Bypass Program command	31
5.2.11	Unlock Bypass Reset command	31
5.3	Extended Memory Block Protection commands	34
5.3.1	Enter Extended Memory Block command	34
5.3.2	Exit Extended Block command	34
6	Status register	37
6.0.1	Data Polling Bit (DQ7)	37
6.0.2	Toggle Bit (DQ6)	37
6.0.3	Error Bit (DQ5)	38
6.0.4	Erase Timer Bit (DQ3)	38
6.0.5	Alternative Toggle Bit (DQ2)	38
6.0.6	Write to Buffer and Program Abort Bit (DQ1)	38

7	Maximum rating	41
8	DC and AC parameters	42
9	Package mechanical	51
10	Part numbering	53
Appendix A Block addresses and Read/Modify Protection Groups		54
Appendix B Common Flash Interface (CFI)		63
Appendix C Extended Memory Block		67
C.1	Factory Locked Extended Memory Block	67
C.2	Customer Lockable Extended Memory Block	68
Appendix D High Voltage Block Protection		69
D.1	Programmer technique	69
D.2	In-System technique	70
Appendix E Flowcharts		71
Revision history		77

List of tables

Table 1.	Signal names	7
Table 2.	Bus operations, 8-bit mode	18
Table 3.	Read Electronic Signature, 8-bit mode	18
Table 4.	Block Protection, 8-bit mode	19
Table 5.	Bus operations, 16-bit mode	19
Table 6.	Read Electronic Signature, 16-bit mode	20
Table 7.	Block Protection, 16-bit mode	20
Table 8.	Hardware Protection	21
Table 9.	Standard commands, 8-bit mode	26
Table 10.	Standard commands, 16-bit mode	27
Table 11.	Fast Program commands, 8-bit mode	32
Table 12.	Fast Program commands, 16-bit mode	33
Table 13.	Extended Block Protection commands, 8-bit mode	35
Table 14.	Block Protection commands, 16-bit mode	35
Table 15.	Program, Erase Times and Program, Erase Endurance cycles	36
Table 16.	Status register bits	39
Table 17.	Absolute maximum ratings	41
Table 18.	Operating and AC measurement conditions	42
Table 19.	Device capacitance	43
Table 20.	DC characteristics	43
Table 21.	Read AC characteristics	46
Table 22.	Write AC characteristics, Write Enable Controlled	47
Table 23.	Write AC characteristics, Chip Enable Controlled	48
Table 24.	Reset/Block Temporary Unprotect AC characteristics	49
Table 25.	TSOP56 – 56 lead Plastic Thin Small Outline, 14 x 20mm, package mechanical data	51
Table 26.	TBGA64 10x13mm - 8x8 active ball array, 1mm pitch, package mechanical data	52
Table 27.	Ordering information scheme	53
Table 28.	Block Addresses and Protection Groups	54
Table 29.	Query Structure Overview	63
Table 30.	CFI Query Identification String	63
Table 31.	CFI Query System Interface Information	64
Table 32.	Device Geometry Definition	64
Table 33.	Primary Algorithm-Specific Extended Query Table	65
Table 34.	Security Code Area	66
Table 35.	Extended Memory Block Address and Data	68
Table 36.	Programmer technique Bus operations, 8-bit or 16-bit mode	70
Table 37.	Document revision history	77

List of figures

Figure 1.	Logic diagram	8
Figure 2.	TSOP connections	9
Figure 3.	TBGA connections (top view through package)	10
Figure 4.	Block addresses	11
Figure 5.	Data Polling flowchart	39
Figure 6.	Toggle flowchart	40
Figure 7.	AC measurement load circuit	42
Figure 8.	AC measurement I/O waveform	43
Figure 9.	Random Read AC waveforms	44
Figure 10.	Page Read AC waveforms (Word mode)	45
Figure 11.	Write AC waveforms, Write Enable Controlled	47
Figure 12.	Write AC waveforms, Chip Enable Controlled	48
Figure 13.	Reset/Block Temporary Unprotect AC waveforms (No Program/Erase ongoing)	49
Figure 14.	Reset/Block Temporary Unprotect during Program/Erase operation AC waveforms	49
Figure 15.	Accelerated Program Timing waveforms	50
Figure 16.	TSOP56 – 56 lead Plastic Thin Small Outline, 14 x 20mm, package outline	51
Figure 17.	TBGA64 10x13mm - 8x8 active ball array, 1mm pitch, package outline	52
Figure 18.	Programmer equipment Group Protect flowchart	71
Figure 19.	Programmer equipment Chip Unprotect flowchart	72
Figure 20.	In-System equipment Group Protect flowchart	73
Figure 21.	In-System equipment Chip Unprotect flowchart	74
Figure 22.	Write to Buffer and Program flowchart and Pseudo Code	75

1 Summary description

The M29W128FH and M29W128FL are 128 Mbit (16Mb x8 or 8Mb x16) non-volatile memories that can be read, erased and reprogrammed. These operations can be performed using a single low voltage (2.7 to 3.6V) supply. At Power-up the memories default to Read mode. The M29W128FH and M29W128FL are divided into 256 thirty-two KWord (sixty-four KByte) uniform blocks.

Program and Erase commands are written to the Command Interface of the memory. An on-chip Program/Erase Controller simplifies the process of programming or erasing the memory by taking care of all of the special operations that are required to update the memory contents. The end of a program or erase operation can be detected and any error conditions identified. The command set required to control the memory is consistent with JEDEC standards.

The Chip Enable, Output Enable and Write Enable signals control the bus operations of the memory. They allow simple connection to most microprocessors, often without additional logic.

The devices support Asynchronous Random Read and Page Read from all blocks of the memory array.

The M29W128FH and M29W128FL have an extra 128 Word (256 Byte) Extended Memory Block that can be accessed using a dedicated command. The Extended Memory Block can be protected and so is useful for storing security information. However the protection is irreversible, once protected the protection cannot be undone.

Each block can be erased independently, so it is possible to preserve valid data while old data is erased.

The devices feature two different levels of hardware block protection to avoid unwanted program or erase (modify):

- The V_{PP}/\overline{WP} pin protects the highest block on the M29W128FH and the lowest block on the M29W128FL.
- The \overline{RP} pin temporarily unprotects all the blocks previously protected using a High Voltage Block Protection technique (see *Appendix D: High Voltage Block Protection*).

The memories are offered in TSOP56 (14 x 20mm) and TBGA64 (10 x 13mm, 1mm pitch) packages.

In order to meet environmental requirements, Numonyx offers the M29W128FH and the M29W128FL in ECOPACK® packages. ECOPACK packages are Lead-free. The category of second Level Interconnect is marked on the package and on the inner box label, in compliance with JEDEC Standard JESD97. The maximum ratings related to soldering conditions are also marked on the inner box label.

The memories are supplied with all the bits erased (set to '1').

The M29W128FH and the M29W128FL will be referred to as M29W128F throughout the document.

Table 1. Signal names

A0-A22	Address Inputs
--------	----------------

Table 1. Signal names

DQ0-DQ7	Data Inputs/Outputs
DQ8-DQ14	Data Inputs/Outputs
DQ15A-1	Data Input/Output or Address Input
\bar{E}	Chip Enable
\bar{G}	Output Enable
\bar{W}	Write Enable
\bar{RP}	Reset/Block Temporary Unprotect
\bar{RB}	Ready/Busy Output
$\overline{\text{BYTE}}$	Byte/Word Organization Select
V_{CC}	Supply voltage
V_{PP}/\bar{WP}	V_{PP} /Write Protect
V_{SS}	Ground
NC	Not Connected Internally

Figure 1. Logic diagram

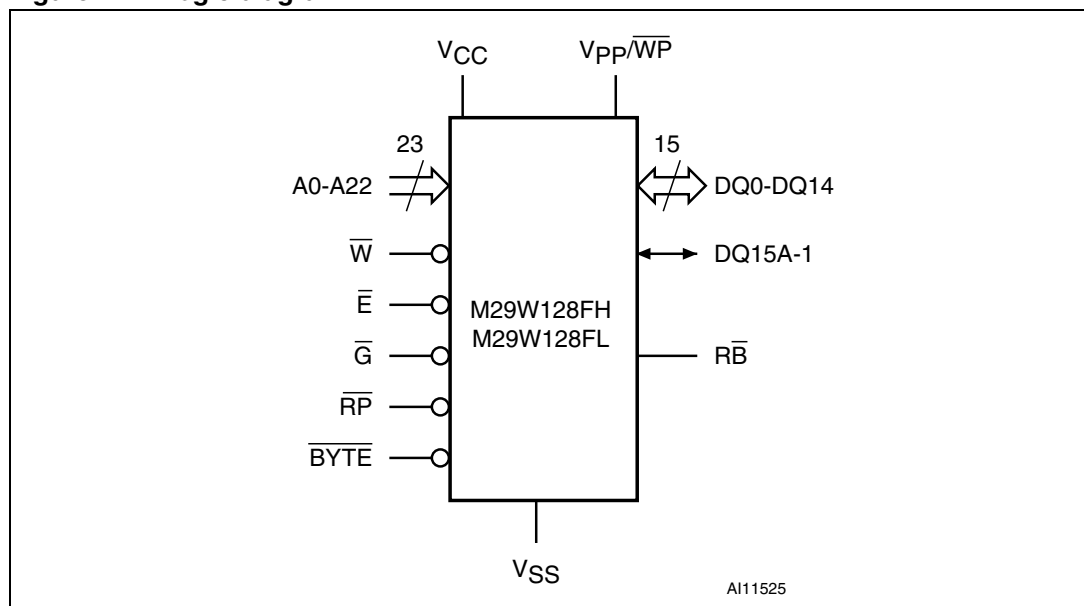

1. Also see *Appendix A* and *Table 28* for a full listing of the Block Addresses.

Figure 2. TSOP connections

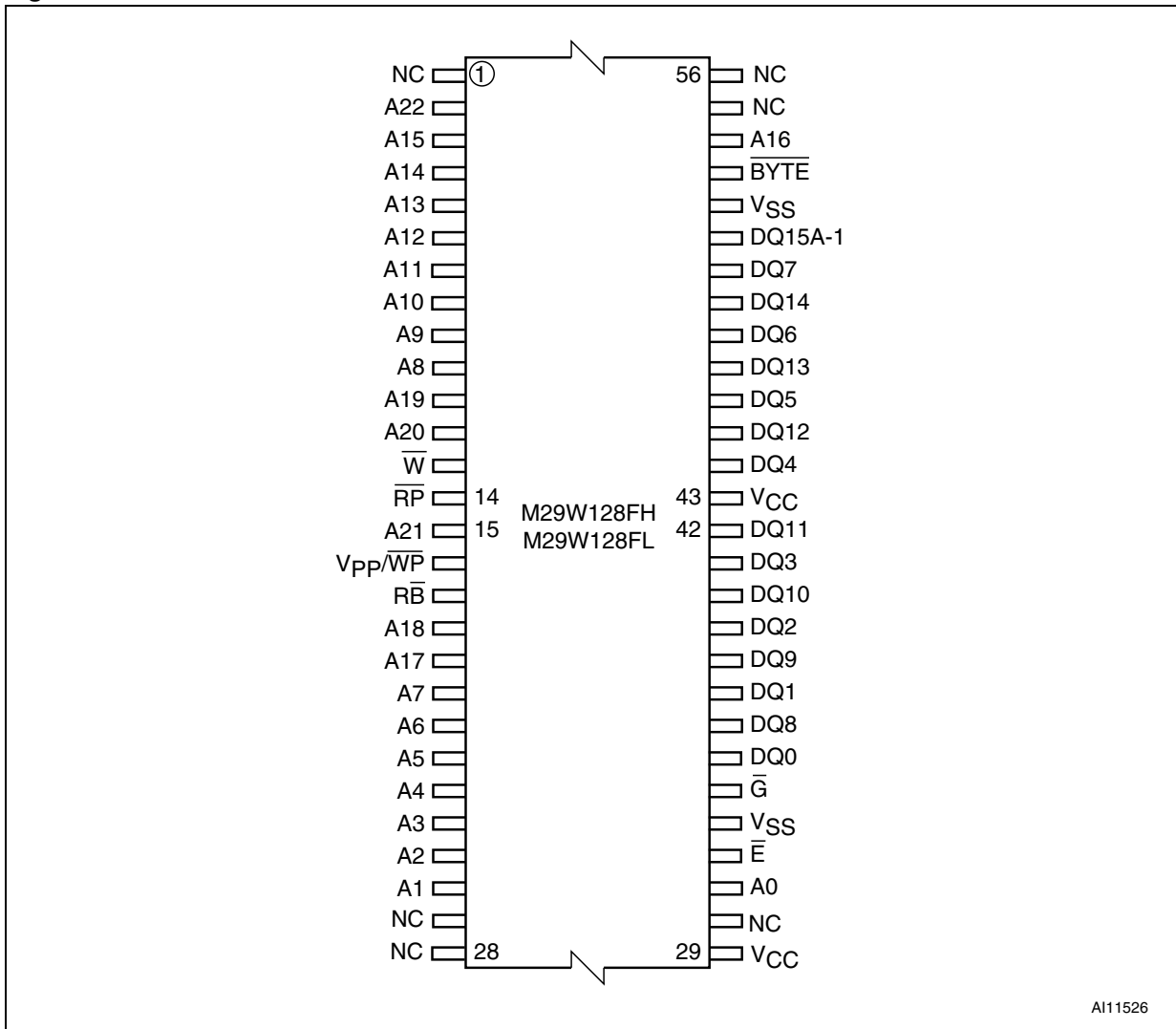

A11526

Figure 3. TBGA connections (top view through package)

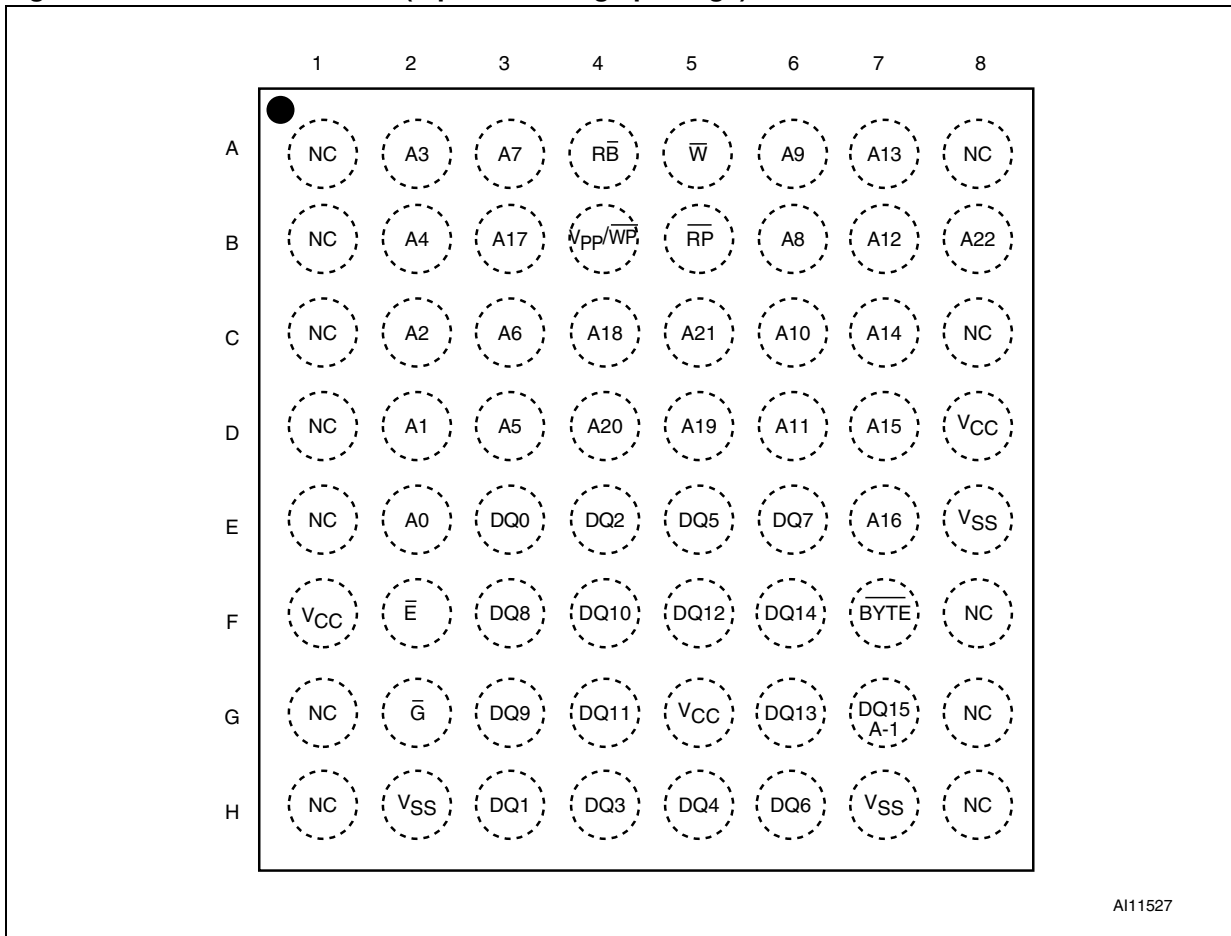
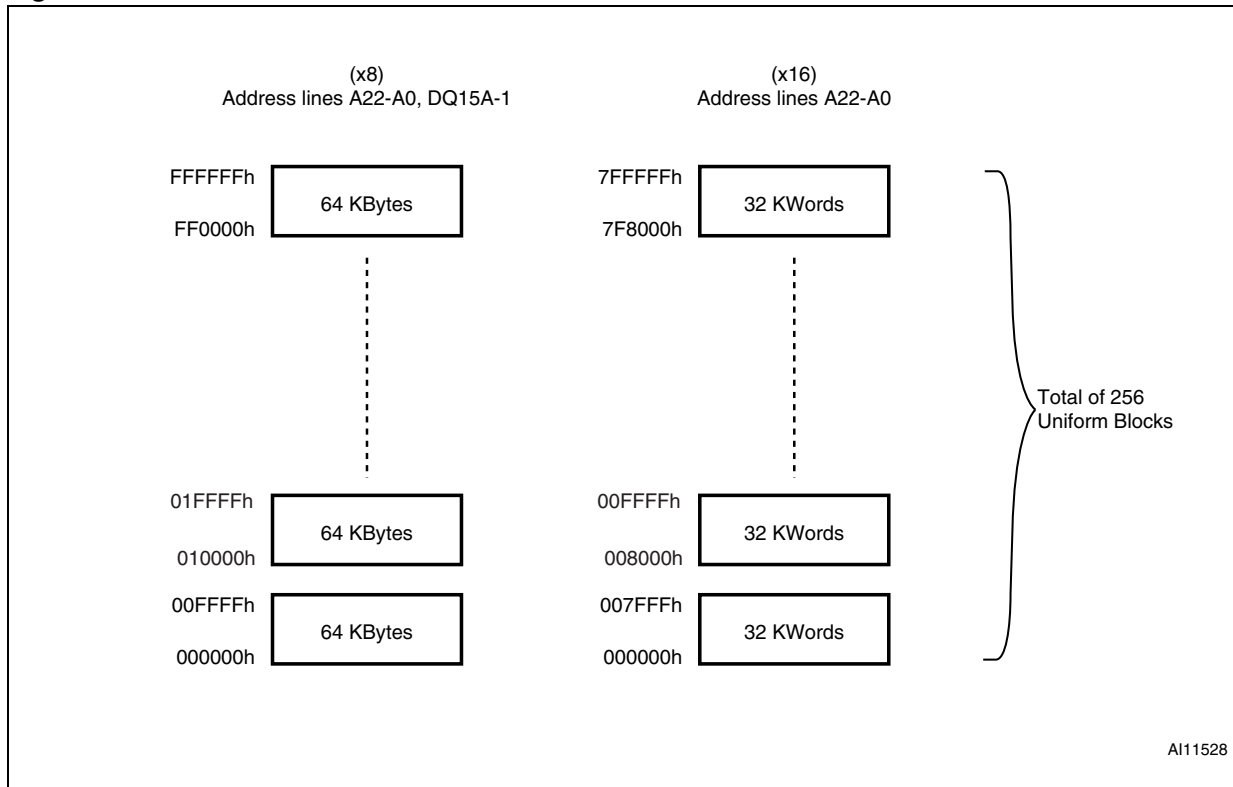

Figure 4. Block addresses



2 Signal descriptions

See *Figure 1: Logic diagram*, and *Table 1: Signal names*, for a brief overview of the signals connected to this device.

2.1 Address Inputs (A0-A22)

The Address Inputs select the cells in the memory array to access during Bus Read operations. During Bus Write operations they control the commands sent to the Command Interface of the Program/Erase Controller.

2.2 Data Inputs/Outputs (DQ0-DQ7)

The Data I/O outputs the data stored at the selected address during a Bus Read operation. During Bus Write operations they represent the commands sent to the Command Interface of the internal state machine.

2.3 Data Inputs/Outputs (DQ8-DQ14)

The Data I/O outputs the data stored at the selected address during a Bus Read operation when $\overline{\text{BYTE}}$ is High, V_{IH} . When $\overline{\text{BYTE}}$ is Low, V_{IL} , these pins are not used and are high impedance. During Bus Write operations the Command Register does not use these bits. When reading the Status Register these bits should be ignored.

2.4 Data Input/Output or Address Input (DQ15A-1)

When the device is in x16 Bus mode, this pin behaves as a Data Input/Output pin (as DQ8-DQ14). When the device is in x8 Bus mode, this pin behaves as an address pin; DQ15A-1 Low will select the LSB of the addressed Word, DQ15A-1 High will select the MSB. Throughout the text consider references to the Data Input/Output to include this pin when the device operates in x16 bus mode and references to the Address Inputs to include this pin when the device operates in x8 bus mode except when stated explicitly otherwise.

2.5 Chip Enable ($\overline{\text{E}}$)

The Chip Enable pin, $\overline{\text{E}}$, activates the memory, allowing Bus Read and Bus Write operations to be performed. When Chip Enable is High, V_{IH} , all other pins are ignored.

2.6 Output Enable ($\overline{\text{G}}$)

The Output Enable pin, $\overline{\text{G}}$, controls the Bus Read operation of the memory.

2.7 Write Enable (\overline{W})

The Write Enable pin, \overline{W} , controls the Bus Write operation of the memory's Command Interface.

2.8 V_{PP} /Write Protect (V_{PP}/\overline{WP})

The V_{PP} /Write Protect pin provides two functions. The V_{PP} function allows the memory to use an external high voltage power supply to reduce the time required for Program operations. This is achieved by bypassing the unlock cycles and/or using the multiple Word (2 or 4 at-a-time) or multiple Byte Program (2, 4 or 8 at-a-time) commands.

The Write Protect function provides a hardware method of protecting the highest or lowest block. When V_{PP} /Write Protect is Low, V_{IL} , the highest or lowest block is protected; Program and Erase operations on this block are ignored while V_{PP} /Write Protect is Low, even when \overline{RP} is at V_{ID} .

When V_{PP} /Write Protect is High, V_{IH} , the memory reverts to the previous protection status of the highest or lowest block. Program and Erase operations can now modify the data in this block unless the block is protected using Block Protection.

Applying V_{PPH} to the V_{PP}/\overline{WP} pin will temporarily unprotect any block previously protected (including the highest or lowest block) using a High Voltage Block Protection technique (In-System or Programmer technique). See *Table 8: Hardware Protection* for details.

When V_{PP} /Write Protect is raised to V_{PP} the memory automatically enters the Unlock Bypass mode. When V_{PP} /Write Protect returns to V_{IH} or V_{IL} normal operation resumes. During Unlock Bypass Program operations the memory draws I_{PP} from the pin to supply the programming circuits. See the description of the Unlock Bypass command in the Command Interface section. The transitions from V_{IH} to V_{PP} and from V_{PP} to V_{IH} must be slower than t_{VHVPP} (see *Figure 15: Accelerated Program Timing waveforms*).

Never raise V_{PP} /Write Protect to V_{PP} from any mode except Read mode, otherwise the memory may be left in an indeterminate state.

The V_{PP} /Write Protect pin must not be left floating or unconnected or the device may become unreliable. A 0.1 μ F capacitor should be connected between the V_{PP} /Write Protect pin and the V_{SS} Ground pin to decouple the current surges from the power supply. The PCB track widths must be sufficient to carry the currents required during Unlock Bypass Program, I_{PP}

2.9 Reset/Block Temporary Unprotect (\overline{RP})

The Reset/Block Temporary Unprotect pin can be used to apply a Hardware Reset to the memory or to temporarily unprotect all the blocks previously protected using a High Voltage Block Protection technique (In-System or Programmer technique). Note that if V_{PP}/\overline{WP} is at V_{IL} , then the highest or lowest block will remain protected even if \overline{RP} is at V_{ID} .

A Hardware Reset is achieved by holding Reset/Block Temporary Unprotect Low, V_{IL} , for at least t_{PLPX} . After Reset/Block Temporary Unprotect goes High, V_{IH} , the memory will be ready for Bus Read and Bus Write operations after t_{PHEL} or t_{RHEL} , whichever occurs last. See Section 2.10: Ready/Busy Output (RB), Table 24: Reset/Block Temporary Unprotect AC characteristics and Figure 13 and Figure 14 for more details.

Holding \overline{RP} at V_{ID} will temporarily unprotect all the blocks previously protected using a High Voltage Block Protection technique. Program and erase operations on all blocks will be possible. The transition from V_{IH} to V_{ID} must be slower than t_{PHPHH} .

2.10 Ready/Busy Output (\overline{RB})

The Ready/Busy pin is an open-drain output that can be used to identify when the device is performing a Program or erase operation. During Program or erase operations Ready/Busy is Low, V_{OL} . Ready/Busy is high-impedance during Read mode, Auto Select mode and Erase Suspend mode.

After a Hardware Reset, Bus Read and Bus Write operations cannot begin until Ready/Busy becomes high-impedance. See Table 24: Reset/Block Temporary Unprotect AC characteristics and Figure 13 and Figure 14.

The use of an open-drain output allows the Ready/Busy pins from several memories to be connected to a single pull-up resistor. A Low will then indicate that one, or more, of the memories is busy.

2.11 Byte/Word Organization Select (\overline{BYTE})

It is used to switch between the x8 and x16 Bus modes of the memory. When Byte/Word Organization Select is Low, V_{IL} , the memory is in x8 mode, when it is High, V_{IH} , the memory is in x16 mode.

2.12 V_{CC} supply voltage (2.7V to 3.6V)

V_{CC} provides the power supply for all operations (Read, Program and Erase).

The Command Interface is disabled when the V_{CC} Supply Voltage is less than the Lockout Voltage, V_{LKO} . This prevents Bus Write operations from accidentally damaging the data during power up, power down and power surges. If the Program/Erase Controller is programming or erasing during this time then the operation aborts and the memory contents being altered will be invalid.

A 0.1 μ F capacitor should be connected between the V_{CC} Supply Voltage pin and the V_{SS} Ground pin to decouple the current surges from the power supply. The PCB track widths must be sufficient to carry the currents required during program and erase operations, I_{CC2} .

2.13 V_{SS} ground

V_{SS} is the reference for all voltage measurements. The device features two V_{SS} pins both of which must be connected to the system ground.

3 Bus operations

There are five standard bus operations that control the device. These are Bus Read (Random and Page modes), Bus Write, Output Disable, Standby and Automatic Standby.

See *Table 2* and *Table 5*, Bus Operations, for a summary. Typically glitches of less than 5ns on Chip Enable, Write Enable, and Reset/Block Temporary Unprotect pins are ignored by the memory and do not affect bus operations.

3.1 Bus Read

Bus Read operations read from the memory cells, or specific registers in the Command Interface. To speed up the read operation the memory array can be read in Page mode where data is internally read and stored in a page buffer. The Page has a size of 8 Words (or 16 Bytes) and is addressed by the address inputs A2-A0 in x16 mode and A2-DQ15A-1 in Byte mode.

A valid Bus Read operation involves setting the desired address on the Address Inputs, applying a Low signal, V_{IL} , to Chip Enable and Output Enable and keeping Write Enable High, V_{IH} . The Data Inputs/Outputs will output the value, see *Figure 9: Random Read AC waveforms*, *Figure 10: Page Read AC waveforms (Word mode)*, and *Table 21: Read AC characteristics*, for details of when the output becomes valid.

3.2 Bus Write

Bus Write operations write to the Command Interface. A valid Bus Write operation begins by setting the desired address on the Address Inputs. The Address Inputs are latched by the Command Interface on the falling edge of Chip Enable or Write Enable, whichever occurs last. The Data Inputs/Outputs are latched by the Command Interface on the rising edge of Chip Enable or Write Enable, whichever occurs first. Output Enable must remain High, V_{IH} , during the whole Bus Write operation. See *Figure 11* and *Figure 12*, Write AC Waveforms, and *Table 22* and *Table 23*, Write AC Characteristics, for details of the timing requirements.

3.3 Output Disable

The Data Inputs/Outputs are in the high impedance state when Output Enable is High, V_{IH} .

3.4 Standby

When Chip Enable is High, V_{IH} , the memory enters Standby mode and the Data Inputs/Outputs pins are placed in the high-impedance state. To reduce the Supply Current to the Standby Supply Current, I_{CC2} , Chip Enable should be held within $V_{CC} \pm 0.3V$. For the Standby current level see *Table 20: DC characteristics*.

During program or erase operations the memory will continue to use the Program/Erase Supply Current, I_{CC3} , for Program or Erase operations until the operation completes.

3.5 Automatic Standby

If CMOS levels ($V_{CC} \pm 0.3V$) are used to drive the bus and the bus is inactive for t_{AVQV+} 30ns or more the memory enters Automatic Standby where the internal Supply Current is reduced to the Standby Supply Current, I_{CC2} . The Data Inputs/Outputs will still output data if a Bus Read operation is in progress.

3.6 Special Bus operations

Additional bus operations can be performed to read the Electronic Signature, verify the Protection Status of the Extended Memory Block, and apply and remove Block Protection. These bus operations are intended for use by programming equipment and are not usually used in applications. They require V_{ID} to be applied to some pins.

3.6.1 Read Electronic Signature

The memory has two codes, the Manufacturer code and the Device code used to identify the memory. These codes can be accessed by performing read operations with control signals and addresses set as shown in *Table 3* and *Table 5*.

These codes can also be accessed by issuing an Auto Select command (see *Section 5.1.2: Auto Select command*).

3.6.2 Verify Extended Memory Block Protection Indicator

The Extended Memory Block is either Factory Locked or Customer Lockable.

The Protection Status of the Extended Memory Block (Factory Locked or Customer Lockable) can be accessed by reading the Extended Memory Block Protection Indicator. This is performed by applying the signals as shown in *Table 4* and *Table 7*. The Protection Status of the Extended Memory Block is then output on bit DQ7 of the Data Input/Outputs. (see *Table 2* and *Table 5*, Bus Operations).

The Protection Status of the Extended Memory Block can also be accessed by issuing an Auto Select command (see *Section 5.1.2: Auto Select command*).

3.6.3 Verify Block Protection Status

The Protection Status of a Block can be directly accessed by performing a read operation with control signals and addresses set as shown in *Table 4* and *Table 7*.

If the Block is protected, then 01h (in x8 mode) is output on Data Input/Outputs DQ0-DQ7, otherwise 00h is output.

3.6.4 Hardware Block Protect

The V_{PP}/\overline{WP} pin can be used to protect the highest or lowest block. When V_{PP}/\overline{WP} is at V_{IL} the highest or lowest block is protected and remains protected regardless of the Block Protection Status or the Reset/Block Temporary Unprotect pin state.

3.6.5 Temporary Unprotect of high voltage Protected Blocks

The \overline{RP} pin can be used to temporarily unprotect all the blocks previously protected using the In-System or the Programmer protection technique (High Voltage techniques).

Refer to Section 2.9: Reset/Block Temporary Unprotect (RP).

Table 2. Bus operations, 8-bit mode

Operation ⁽¹⁾	\overline{E}	\overline{G}	\overline{W}	\overline{RP}	V_{PP}/\overline{WP}	Address Inputs	Data Inputs/Outputs	
						A22-A0, DQ15A-1	DQ14-DQ8	DQ7-DQ0
Bus Read	V_{IL}	V_{IL}	V_{IH}	V_{IH}	V_{IH}	Cell Address	Hi-Z	Data Output
Bus Write	V_{IL}	V_{IH}	V_{IL}	V_{IH}	V_{IH}	Command Address	Hi-Z	Data Input
Output Disable	X	V_{IH}	V_{IH}	V_{IH}	V_{IH}	X	Hi-Z	Hi-Z
Standby	V_{IH}	X	X	V_{IH}	V_{IH}	X	Hi-Z	Hi-Z

1. X = V_{IL} or V_{IH} .

Table 3. Read Electronic Signature, 8-bit mode

Read Cycle ⁽¹⁾	\overline{E}	\overline{G}	\overline{W}	Address Inputs										Data Inputs/Outputs		
				A22-A10	A9	A8-A7	A6	A5-A4	A3	A2	A1	A0	DQ15A-1	DQ14-DQ8	DQ7-DQ0	
Manufacturer Code	V_{IL}	V_{IL}	V_{IH}	X	V_{ID}	X	V_{IL}	X	V_{IL}	V_{IL}	V_{IL}	V_{IL}	X	Hi-Z	20h	
Device Code (Cycle 1)									V_{IL}	V_{IL}	V_{IL}	V_{IH}	X	Hi-Z	7Eh (Both Devices)	
Device Code (Cycle 2)									V_{IH}	V_{IH}	V_{IH}	V_{IL}	X	Hi-Z	12h (Both Devices)	
Device Code (Cycle 3)									V_{IH}	V_{IH}	V_{IH}	V_{IH}	X	Hi-Z	8Ah (M29W128FH) 8Bh (M29W128FL)	

1. X = V_{IL} or V_{IH} .

Table 4. Block Protection, 8-bit mode

Operation (1)	\bar{E}	\bar{G}	\bar{W}	\bar{RP}	V_{PP}/WP	Address Inputs										Data Inputs/Outputs	
						A22-A12	A11-A10	A9	A8-A7	A6	A5-A4	A3-A2	A1	A0	DQ15-A-1	DQ14-DQ8	DQ7-DQ0
Verify Extended Memory Block Protection Indicator (bit DQ7)	V_{IL}	V_{IL}	V_{IH}	V_{IH}	V_{IH}	BA	X	V_{ID}	X	V_{IL}	X	V_{IL}	V_{IH}	V_{IH}	X	Hi-Z	M29W128FH 88h (factory locked) 08h (customer lockable)
Verify Block Protection Status													V_{IL}				01h (protected) 00h (unprotected)
Temporary Block Unprotect (2)	X	X	X	V_{ID}	X	Valid											Data Input

1. X = V_{IL} or V_{IH} . BA any Address in the Block.
2. The \bar{RP} pin unprotects all the blocks that have been previously protected using a High Voltage protection Technique.

Table 5. Bus operations, 16-bit mode

Operation(1)	\bar{E}	\bar{G}	\bar{W}	\bar{RP}	V_{PP}/WP	Address Inputs	Data Inputs/Outputs
						A22-A0	DQ15A-1, DQ14-DQ0
Bus Read	V_{IL}	V_{IL}	V_{IH}	V_{IH}	V_{IH}	Cell Address	Data Output
Bus Write	V_{IL}	V_{IH}	V_{IL}	V_{IH}	V_{IH}	Command Address	Data Input
Output Disable	X	V_{IH}	V_{IH}	V_{IH}	V_{IH}	X	Hi-Z
Standby	V_{IH}	X	X	V_{IH}	V_{IH}	X	Hi-Z

1. X = V_{IL} or V_{IH} .

Table 6. Read Electronic Signature, 16-bit mode

Read Cycle ⁽¹⁾	\bar{E}	\bar{G}	\bar{W}	Address Inputs										Data Inputs/Outputs
				A22-A10	A9	A8-A7	A6	A5-A4	A3	A2	A1	A0	DQ15A-1, DQ14-DQ0	
Manufacturer Code	V _{IL}	V _{IL}	V _{IH}	X	V _{ID}	X	V _{IL}	X	V _{IL}	V _{IL}	V _{IL}	V _{IL}	0020h	
Device Code (Cycle 1)									V _{IL}	V _{IL}	V _{IL}	V _{IH}	227Eh (Both Devices)	
Device Code (Cycle 2)									V _{IH}	V _{IH}	V _{IH}	V _{IL}	2212h (Both Devices)	
Device Code (Cycle 3)									V _{IH}	V _{IH}	V _{IH}	V _{IH}	228Ah (M29W128FH) 228Bh (M29W128FL)	

1. X = V_{IL} or V_{IH}.

Table 7. Block Protection, 16-bit mode

Operation ⁽¹⁾	\bar{E}	\bar{G}	\bar{W}	\bar{RP}	$\frac{V_{PP}}{WP}$	Address Inputs										Data Inputs/Outputs	
						A22-A12	A11-A10	A9	A8-A7	A6	A5-A4	A3-A2	A1	A0	DQ15A-1, DQ14-DQ0		
Verify Extended Memory Block Indicator (bit DQ7)	V _{IL}	V _{IL}	V _{IH}	V _{IH}	V _{IH}	BA	X	V _{ID}	X	V _{IL}	X	V _{IL}	V _{IH}	V _{IH}	M29W128FH 0088h (factory locked) 0008h (customer lockable)		
														V _{IH}	M29W128FL 0098h (factory locked) 0018h (customer lockable)		
Verify Block Protection Status	X	X	X	V _{ID}	X	Valid										V _{IL}	0001h (protected) 0000h (unprotected)
Temporary Block Unprotect ⁽²⁾						Valid										V _{IL}	Data Input

1. X = V_{IL} or V_{IH}. BA Any Address in the Block.

2. The \bar{RP} pin unprotects all the blocks that have been previously protected using a High Voltage protection Technique.

4 Hardware protection

The M29W128F features hardware protection/unprotection. Refer to *Table 8* for details on hardware block protection/unprotection using V_{PP}/\overline{WP} and \overline{RP} pins.

4.1 Write Protect

The V_{PP}/\overline{WP} pin protects the highest or lowest block (refer to *Section 2: Signal descriptions* for a detailed description of the signals).

4.2 Temporary Block Unprotect

When held at V_{ID} , the Reset/Block Temporary Unprotect pin, \overline{RP} , will temporarily unprotect all the blocks previously protected using a High Voltage Block Protection technique.

Table 8. Hardware Protection

V_{PP}/\overline{WP}	\overline{RP}	Function
V_{IL}	V_{IH}	Highest or lowest block protected from Program/Erase operations
	V_{ID}	All blocks temporarily unprotected except the highest or lowest block
V_{IH} or V_{ID}	V_{ID}	All blocks temporarily unprotected
V_{PPH}	V_{IH} or V_{ID}	All blocks temporarily unprotected

5 Command interface

All Bus Write operations to the memory are interpreted by the Command Interface. Commands consist of one or more sequential Bus Write operations. Failure to observe a valid sequence of Bus Write operations will result in the memory returning to Read mode. The long command sequences are imposed to maximize data security.

The address used for the commands changes depending on whether the memory is in 16-bit or 8-bit mode.

5.1 Standard commands

See either *Table 9*, or *Table 10*, depending on the configuration that is being used, for a summary of the Standard commands.

5.1.1 Read/Reset command

The Read/Reset command returns the memory to Read mode. It also resets the errors in the Status Register. Either one or three Bus Write operations can be used to issue the Read/Reset command.

The Read/Reset command can be issued, between Bus Write cycles before the start of a program or erase operation, to return the device to Read mode. If the Read/Reset command is issued during the time-out of a Block erase operation, the memory will take up to 10 μ s to abort. During the abort period no valid data can be read from the memory.

The Read/Reset command will not abort an Erase operation when issued while in Erase Suspend.

5.1.2 Auto Select command

The Auto Select command is used to read the Manufacturer Code, the Device Code, the Protection Status of each block (Block Protection Status) and the Extended Memory Block Protection Indicator.

Three consecutive Bus Write operations are required to issue the Auto Select command. Once the Auto Select command is issued Bus Read operations to specific addresses output the Manufacturer Code, the Device Code, the Extended Memory Block Protection Indicator and a Block Protection Status (see *Table 9* and *Table 10* in conjunction with *Table 3*, *Table 4*, *Table 6* and *Table 7*). The memory remains in Auto Select mode until a Read/Reset or CFI Query command is issued.

5.1.3 Read CFI Query command

The Read CFI Query Command is used to put the memory in Read CFI Query mode. Once in Read CFI Query mode, Bus Read operations to the memory will output data from the Common Flash Interface (CFI) Memory Area. One Bus Write cycle is required to issue the Read CFI Query Command. This command is valid only when the device is in the Read Array or Auto Select mode.

The Read/Reset command must be issued to return the device to the previous mode (the Read Array mode or Auto Select mode). A second Read/Reset command is required to put the device in Read Array mode from Auto Select mode.

See *Appendix B, Table 29, Table 30, Table 31, Table 32, Table 33 and Table 34* for details on the information contained in the Common Flash Interface (CFI) memory area.

5.1.4 Chip Erase command

The Chip Erase command can be used to erase the entire chip. Six Bus Write operations are required to issue the Chip Erase Command and start the Program/Erase Controller.

If any blocks are protected, then these are ignored and all the other blocks are erased. If all of the blocks are protected the Chip Erase operation appears to start but will terminate within about 100 μ s, leaving the data unchanged. No error condition is given when protected blocks are ignored.

During the erase operation the memory will ignore all commands, including the Erase Suspend command. It is not possible to issue any command to abort the operation. Typical chip erase times are given in *Table 15*. All Bus Read operations during the Chip Erase operation will output the Status Register on the Data Inputs/Outputs. See the section on the Status Register for more details.

After the Chip Erase operation has completed the memory will return to the Read mode, unless an error has occurred. When an error occurs the memory will continue to output the Status Register. A Read/Reset command must be issued to reset the error condition and return to Read mode.

The Chip Erase Command sets all of the bits in unprotected blocks of the memory to '1'. All previous data is lost.

5.1.5 Block Erase command

The Block Erase command can be used to erase a list of one or more blocks. It sets all of the bits in the unprotected selected blocks to '1'. All previous data in the selected blocks is lost.

Six Bus Write operations are required to select the first block in the list. Each additional block in the list can be selected by repeating the sixth Bus Write operation using the address of the additional block. The Block Erase operation starts the Program/Erase Controller after a time-out period of 50 μ s after the last Bus Write operation. Once the Program/Erase Controller starts it is not possible to select any more blocks. Each additional block must therefore be selected within 50 μ s of the last block. The 50 μ s timer restarts when an additional block is selected. After the sixth Bus Write operation, a Bus Read operation outputs the Status Register. See *Section 6: Status register* for details on how to identify if the Program/Erase Controller has started the Block Erase operation.

After the Block Erase operation has completed, the memory returns to the Read mode, unless an error has occurred. When an error occurs, Bus Read operations will continue to output the Status Register. A Read/Reset command must be issued to reset the error condition and return to Read mode.

If any selected blocks are protected then these are ignored and all the other selected blocks are erased. If all of the selected blocks are protected the Block Erase operation appears to start but will terminate within about 100 μ s, leaving the data unchanged. No error condition is given when protected blocks are ignored.

During the Block Erase operation the memory will ignore all commands except the Erase Suspend command and the Read/Reset command which is only accepted during the 50 μ s time-out period. Typical block erase times are given in *Table 15*.

5.1.6 Erase Suspend command

The Erase Suspend command may be used to temporarily suspend a Block or multiple Block Erase operation. One Bus Write operation is required to issue the command. Issuing the Erase Suspend command returns the whole device to Read mode.

The Program/Erase Controller will suspend within the Erase Suspend Latency time (see *Table 15: Program, Erase Times and Program, Erase Endurance cycles*) of the Erase Suspend Command being issued. Once the Program/Erase Controller has stopped the memory will be set to Read mode and the Erase will be suspended. If the Erase Suspend command is issued during the period when the memory is waiting for an additional block (before the Program/Erase Controller starts) then the Erase is suspended immediately and will start immediately when the Erase Resume Command is issued. It is not possible to select any further blocks to erase after the Erase Resume.

During Erase Suspend it is possible to Read and Program cells in blocks that are not being erased; both Read and Program operations behave as normal on these blocks. If any attempt is made to program in a protected block or in the suspended block then the Program command is ignored and the data remains unchanged. The Status Register is not read and no error condition is given. Reading from blocks that are being erased will output the Status Register.

It is also possible to issue the Auto Select, Read CFI Query and Unlock Bypass commands during an Erase Suspend. The Read/Reset command must be issued to return the device to Read Array mode before the Resume command will be accepted.

During Erase Suspend a Bus Read operation to the Extended Memory Block will output the Extended Memory Block data. Once in the Extended Block mode, the Exit Extended Block command must be issued before the erase operation can be resumed.

5.1.7 Erase Resume command

The Erase Resume command is used to restart the Program/Erase Controller after an Erase Suspend.

The device must be in Read Array mode before the Resume command will be accepted. An Erase can be suspended and resumed more than once.

5.1.8 Program Suspend command

The Program Suspend command allows the system to interrupt a program operation so that data can be read from any block. When the Program Suspend command is issued during a program operation, the device suspends the program operation within the Program Suspend Latency time (see *Table 15: Program, Erase Times and Program, Erase Endurance cycles*) and updates the Status Register bits.

After the program operation has been suspended, the system can read array data from any address. However, data read from Program-Suspended addresses is not valid.

The Program Suspend command may also be issued during a program operation while an erase is suspended. In this case, data may be read from any addresses not in Erase Suspend or Program Suspend. If a read is needed from the Extended Memory Block area (One-time Program area), the user must use the proper command sequences to enter and exit this region.

The system may also issue the Auto Select command sequence when the device is in the Program Suspend mode. The system can read as many Auto Select codes as required.

When the device exits the Auto Select mode, the device reverts to the Program Suspend mode, and is ready for another valid operation. See Auto Select command sequence for more information.

5.1.9 Program Resume command

After the Program Resume command is issued, the device reverts to programming. The controller can determine the status of the program operation using the DQ7 or DQ6 status bits, just as in the standard program operation. Refer to *Section 6: Status register* for details.

The system must issue a Program Resume command, to exit the Program Suspend mode and to continue the programming operation.

Further issuing of the Resume command is ignored. Another Program Suspend command can be written after the device has resumed programming.

5.1.10 Program command

The Program command can be used to program a value to one address in the memory array at a time. The command requires four Bus Write operations, the final Write operation latches the address and data in the internal state machine and starts the Program/Erase Controller.

Programming can be suspended and then resumed by issuing a Program Suspend command and a Program Resume command, respectively (see *Section 5.1.8: Program Suspend command* and *Section 5.1.9: Program Resume command*).

If the address falls in a protected block then the Program command is ignored, the data remains unchanged. The Status Register is never read and no error condition is given.

After programming has started, Bus Read operations output the Status Register content. See *Section 6: Status register* for more details. Typical program times are given in *Table 15: Program, Erase Times and Program, Erase Endurance cycles*.

After the program operation has completed the memory will return to the Read mode, unless an error has occurred. When an error occurs, Bus Read operations to the memory continue to output the Status Register. A Read/Reset command must be issued to reset the error condition and return to Read mode.

One of the Erase Commands must be used to set all the bits in a block or in the whole memory from '0' to '1'.

Table 9. Standard commands, 8-bit mode

Command		Length	Bus operations ⁽¹⁾⁽²⁾											
			1st		2nd		3rd		4th		5th		6th	
			Add	Data	Add	Data	Add	Data	Add	Data	Add	Data	Add	Data
Read/Reset		1	X	F0										
		3	AAA	AA	555	55	X	F0						
Auto Select	Manufacturer Code	3	AAA	AA	555	55	AAA	90	(3)	(3)				
	Device Code													
	Extended Memory Block Protection Indicator													
	Block Protection Status													
Program		4	AAA	AA	555	55	AAA	A0	PA	PD				
Chip Erase		6	AAA	AA	555	55	AAA	80	AAA	AA	555	55	AAA	10
Block Erase		6 +	AAA	AA	555	55	AAA	80	AAA	AA	555	55	BA	30
Erase/Program Suspend		1	X	B0										
Erase/Program Resume		1	X	30										
Read CFI Query		1	AA	98										

1. Grey cells represent Read cycles. The other cells are Write cycles.
2. X Don't Care, PA Program Address, PD Program Data, BA Any address in the Block. All values in the table are in hexadecimal.
3. The Auto Select addresses and data are given in *Table 3: Read Electronic Signature, 8-bit mode*, and *Table 4: Block Protection, 8-bit mode*, except for A9 that is 'Don't Care'.

Table 10. Standard commands, 16-bit mode

Command		Length	Bus operations ⁽¹⁾⁽²⁾											
			1st		2nd		3rd		4th		5th		6th	
			Add	Data	Add	Data	Add	Data	Add	Data	Add	Data	Add	Data
Read/Reset		1	X	F0										
		3	555	AA	2AA	55	X	F0						
Auto Select	Manufacturer Code	3	555	AA	2AA	55	555	90	(3)	(3)				
	Device Code													
	Extended Memory Block Protection Indicator													
	Block Protection Status													
Program		4	555	AA	2AA	55	555	A0	PA	PD				
Chip Erase		6	555	AA	2AA	55	555	80	555	AA	2AA	55	555	10
Block Erase		6+	555	AA	2AA	55	555	80	555	AA	2AA	55	BA	30
Erase/Program Suspend		1	X	B0										
Erase/Program Resume		1	X	30										
Read CFI Query		1	55	98										

1. Gray cells represent Read cycles. The other cells are Write cycles.
2. X Don't Care, PA Program Address, PD Program Data, BA any address in the Block. All values in the table are in hexadecimal.
3. The Auto Select addresses and data are given in *Table 6: Read Electronic Signature, 16-bit mode*, and *Table 7: Block Protection, 16-bit mode*, except for A9 that is 'Don't Care'.

5.2 Fast Program commands

The M29W128F offers a set of Fast Program commands to improve the programming throughput:

- Write to Buffer and Program
- Double and Quadruple Word, Program
- Double, Quadruple and Octuple Byte Program
- Unlock Bypass.

See either *Table 12*, or *Table 11*, depending on the configuration that is being used, for a summary of the Fast Program commands.

When V_{PPH} is applied to the $V_{PP}/\overline{Write\ Protect}$ pin the memory automatically enters the Fast Program mode. The user can then choose to issue any of the Fast Program commands. Care must be taken because applying a V_{PPH} to the V_{PP}/\overline{WP} pin will temporarily unprotect any protected block.

After programming has started, Bus Read operations in the memory output the Status Register content. Fast program commands can be suspended and then resumed by issuing a Program Suspend command and a Program Resume command, respectively (see *Section 5.1.8: Program Suspend command* and *Section 5.1.9: Program Resume command*)

After the fast program operation has completed, the memory will return to the Read mode, unless an error has occurred. When an error occurs Bus Read operations to the memory will continue to output the Status Register. A Read/Reset command must be issued to reset the error condition and return to Read mode. One of the Erase Commands must be used to set all the bits in a block or in the whole memory from '0' to '1'.

Typical Program times are given in *Table 15: Program, Erase Times and Program, Erase Endurance cycles*.

5.2.1 Write to Buffer and Program command

The Write to Buffer and Program Command makes use of the device's 64-Byte Write Buffer to speed up programming. 32 Words/64 Bytes can be loaded into the Write Buffer. Each Write Buffer has the same A22-A5 addresses. The Write to Buffer and Program command dramatically reduces system programming time compared to the standard non-buffered Program command.

When issuing a Write to Buffer and Program command, the V_{PP}/\overline{WP} pin can be either held High, V_{IH} or raised to V_{PPH} .

See *Table 15* for details on typical Write to Buffer and Program times in both cases.

Five successive steps are required to issue the Write to Buffer and Program command:

1. The Write to Buffer and Program command starts with two unlock cycles.
2. The third Bus Write cycle sets up the Write to Buffer and Program command. The setup code can be addressed to any location within the targeted block.
3. The fourth Bus Write cycle sets up the number of Words/Bytes to be programmed. Value N is written to the same block address, where N+1 is the number of Words/Bytes to be programmed. N+1 must not exceed the size of the Write Buffer or the operation will abort.
4. The fifth cycle loads the first address and data to be programmed.

Use N Bus Write cycles to load the address and data for each Word/Byte into the Write Buffer. Addresses must lie within the range from the start address+1 to the start address + N-1. Optimum performance is obtained when the start address corresponds to a 64 Byte boundary. If the start address is not aligned to a 64 Byte boundary, the total programming time is doubled.

All the addresses used in the Write to Buffer and Program operation must lie within the same page.

To program the content of the Write Buffer, this command must be followed by a Write to Buffer and Program Confirm command.

If an address is written several times during a Write to Buffer and Program operation, the address/data counter will be decremented at each data load operation and the data will be programmed to the last word loaded into the Buffer.

Invalid address combinations or failing to follow the correct sequence of Bus Write cycles will abort the Write to Buffer and Program.

The Status Register bits DQ1, DQ5, DQ6, DQ7 can be used to monitor the device status during a Write to Buffer and Program operation.

It is not possible to detect Program operation fails when changing programmed data from '0' to '1', that is when reprogramming data in a portion of memory already programmed. The resulting data will be the logical OR between the previous value and the current value.

A Write to Buffer and Program Abort and Reset command must be issued to abort the Write to Buffer and Program operation and reset the device in Read mode.

See *Appendix E, Figure 22: Write to Buffer and Program flowchart and Pseudo Code*, for a suggested flowchart on using the Write to Buffer and Program command.

5.2.2 Write to Buffer and Program Confirm command

The Write to Buffer and Program Confirm command is used to confirm a Write to Buffer and Program command and to program the N+1 Words/Bytes loaded in the Write Buffer by this command.

5.2.3 Write to Buffer and Program Abort and Reset command

The Write to Buffer and Program Abort and Reset command is used to abort Write to Buffer and Program command.

5.2.4 Double Word Program command

This is used to write two adjacent Words in x16 mode, simultaneously. The addresses of the two Words must differ only in A0.

Three bus write cycles are necessary to issue the command:

1. The first bus cycle sets up the command.
2. The second bus cycle latches the Address and the Data of the first Word to be written.
3. The third bus cycle latches the Address and the Data of the second Word to be written and starts the Program/Erase Controller.

5.2.5 Quadruple Word Program command

This is used to write a page of four adjacent Words (or 8 adjacent Bytes), in x16 mode, simultaneously. The addresses of the four Words must differ only in A1 and A0.

Five bus write cycles are necessary to issue the command:

1. The first bus cycle sets up the command.
2. The second bus cycle latches the Address and the Data of the first Word to be written.
3. The third bus cycle latches the Address and the Data of the second Word to be written.
4. The fourth bus cycle latches the Address and the Data of the third Word to be written.
5. The fifth bus cycle latches the Address and the Data of the fourth Word to be written and starts the Program/Erase Controller.

5.2.6 Double Byte Program command

This is used to write two adjacent Bytes in x8 mode, simultaneously. The addresses of the two Bytes must differ only in DQ15A-1.

Three bus write cycles are necessary to issue the command:

6. The first bus cycle sets up the command.
7. The second bus cycle latches the Address and the Data of the first Byte to be written.
8. The third bus cycle latches the Address and the Data of the second Byte to be written and starts the Program/Erase Controller.

5.2.7 Quadruple Byte Program command

This is used to write four adjacent Bytes in x8 mode, simultaneously. The addresses of the four Bytes must differ only in A0, DQ15A-1.

Five bus write cycles are necessary to issue the command.

1. The first bus cycle sets up the command.
2. The second bus cycle latches the Address and the Data of the first Byte to be written.
3. The third bus cycle latches the Address and the Data of the second Byte to be written.
4. The fourth bus cycle latches the Address and the Data of the third Byte to be written.
5. The fifth bus cycle latches the Address and the Data of the fourth Byte to be written and starts the Program/Erase Controller.

5.2.8 Octuple Byte Program command

This is used to write eight adjacent Bytes, in x8 mode, simultaneously. The addresses of the eight Bytes must differ only in A1, A0 and DQ15A-1.

Nine bus write cycles are necessary to issue the command:

1. The first bus cycle sets up the command.
2. The second bus cycle latches the Address and the Data of the first Byte to be written.
3. The third bus cycle latches the Address and the Data of the second Byte to be written.
4. The fourth bus cycle latches the Address and the Data of the third Byte to be written.
5. The fifth bus cycle latches the Address and the Data of the fourth Byte to be written.
6. The sixth bus cycle latches the Address and the Data of the fifth Byte to be written.
7. The seventh bus cycle latches the Address and the Data of the sixth Byte to be written.
8. The eighth bus cycle latches the Address and the Data of the seventh Byte to be written.
9. The ninth bus cycle latches the Address and the Data of the eighth Byte to be written and starts the Program/Erase Controller.

5.2.9 Unlock Bypass command

The Unlock Bypass command is used in conjunction with the Unlock Bypass Program command to program the memory faster than with the standard program commands. When the cycle time to the device is long, considerable time saving can be made by using these commands. Three Bus Write operations are required to issue the Unlock Bypass command.

Once the Unlock Bypass command has been issued, the memory enters Unlock Bypass mode. When in Unlock Bypass mode, only the Unlock Bypass Program and Unlock Bypass Reset commands are valid. The Unlock Bypass Program command can then be issued to program addresses within the memory, or the Unlock Bypass Reset command can be issued to return the memory to Read mode. In Unlock Bypass mode the memory can be read as if in Read mode.

5.2.10 Unlock Bypass Program command

The Unlock Bypass Program command can be used to program one address in the memory array at a time. The command requires two Bus Write operations, the final write operation latches the address and data and starts the Program/Erase Controller.

The Program operation using the Unlock Bypass Program command behaves identically to the Program operation using the Program command. The operation cannot be aborted, a Bus Read operation to the memory outputs the Status Register. See the Program command for details on the behavior.

5.2.11 Unlock Bypass Reset command

The Unlock Bypass Reset command can be used to return to Read/Reset mode from Unlock Bypass mode. Two Bus Write operations are required to issue the Unlock Bypass Reset command. Read/Reset command does not exit from Unlock Bypass mode.

Table 11. Fast Program commands, 8-bit mode

Command	Length	Bus Write operations ⁽¹⁾																	
		1st		2nd		3rd		4th		5th		6th		7th		8th		9th	
		Add	Data	Add	Data	Add	Data	Add	Data	Add	Data	Add	Data	Add	Data	Add	Data	Add	Data
Write to Buffer and Program	N+5	AAA	AA	555	55	BA	25	BA	N ⁽²⁾	PA ⁽³⁾	PD	WBL ⁽⁴⁾	PD						
Write to Buffer and Program Abort and Reset	3	AAA	AA	555	55	AAA	F0												
Write to Buffer and Program Confirm	1	BA ⁽⁵⁾	29																
Double Byte Program	3	AAA	50	PA0	PD0	PA1	PD1												
Quadruple Byte Program	5	AAA	56	PA0	PD0	PA1	PD1	PA2	PD2	PA3	PD3								
Octuple Byte Program	9	AAA	8B	PA0	PD0	PA1	PD1	PA2	PD2	PA3	PD3	PA4	PD4	PA5	PD5	PA6	PD6	PA7	PD7
Unlock Bypass	3	AAA	AA	555	55	AAA	20												
Unlock Bypass Program	2	X	A0	PA	PD														
Unlock Bypass Reset	2	X	90	X	00														

1. X Don't Care, PA Program Address, PD Program Data, BA Any address in the Block, WBL Write Buffer Location. All values in the table are in hexadecimal.
2. The maximum number of cycles in the command sequence is 68. N+1 is the number of Bytes to be programmed during the Write to Buffer and Program operation.
3. Each buffer has the same A22-A5 addresses. A0-A4 and A-1 are used to select a Byte within the N+1 Byte page.
4. The 6th cycle has to be issued N time. WBL scans the Word inside the page.
5. BA must be identical to the address loaded during the Write to buffer and Program 3rd and 4th cycles.

Table 12. Fast Program commands, 16-bit mode

Command	Length	Bus Write operations ⁽¹⁾											
		1st		2nd		3rd		4th		5th		6th	
		Add	Data	Add	Data	Add	Data	Add	Data	Add	Data	Add	Data
Write to Buffer and Program	N+5	555	AA	2AA	55	BA	25	BA	N ⁽²⁾	PA ⁽³⁾	PD	WBL ₍₄₎	PD
Write to Buffer and Program Abort and Reset	3	555	AA	2AA	55	555	F0						
Write to Buffer and Program Confirm	1	BA ⁽⁵⁾	29										
Double Word Program	3	555	50	PA0	PD0	PA1	PD1						
Quadruple Word Program	5	555	56	PA0	PD0	PA1	PD1	PA2	PD2	PA3	PD3		
Unlock Bypass	3	555	AA	2AA	55	555	20						
Unlock Bypass Program	2	X	A0	PA	PD								
Unlock Bypass Reset	2	X	90	X	00								

1. X Don't Care, PA Program Address, PD Program Data, BA Any address in the Block, WBL Write Buffer Location. All values in the table are in hexadecimal.
2. The maximum number of cycles in the command sequence is 36. N+1 is the number of Words to be programmed during the Write to Buffer and Program operation.
3. Each buffer has the same A22-A5 addresses. A0-A4 are used to select a Word within the N+1 Word page.
4. The 6th cycle has to be issued N time. WBL scans the Word inside the page.
5. BA must be identical to the address loaded during the Write to buffer and Program 3rd and 4th cycles.

5.3 Extended Memory Block Protection commands

The M29W128F offers a set of commands to access the Extended Memory Block and to configure and check its protection mode.

The commands related to the Extended Memory Block Protection are available in both 8 bit and 16 bit memory configuration.

5.3.1 Enter Extended Memory Block command

The M29W128F has one extra 128 Word block (Extended Memory Block) that can only be accessed using the Enter Extended Memory Block command.

Three Bus Write cycles are required to issue the Extended Memory Block command. Once the command has been issued the device enters the Extended Memory Block mode where all Bus Read or Program operations are conducted on the Extended Memory Block. Once the device is in the Extended Block mode, the Extended Memory Block is addressed by using the addresses occupied by block 0 in the other operating modes (see *Table 28: Block Addresses and Protection Groups*).

The device remains in Extended Block mode until the Exit Extended Block command is issued or power is removed from the device. After power-up or a hardware reset, the device reverts to the Read mode where commands issued to block 0 address space will address block 0.

Note that when the device is in the Extended Block mode, the V_{PP}/\overline{WP} pin cannot be used for fast programming and the Unlock Bypass mode is not available.

The Extended Memory Block cannot be erased, and can be treated as one-time programmable (OTP) memory.

In Extended Block mode, Erase, Chip Erase, Erase Suspend and Erase resume commands are not allowed.

To exit from the Extended Block mode the Exit Extended Block command must be issued.

The Extended Memory Block can be protected by setting the Extended Memory Block Protection Bit to '1'; however once protected the protection cannot be undone.

5.3.2 Exit Extended Block command

The Exit Extended Block command is used to exit from the Extended Block mode and return the device to Read mode. Four Bus Write operations are required to issue the command.

Table 13. Extended Block Protection commands, 8-bit mode

Command	Length	Bus operations ⁽¹⁾⁽²⁾											
		1st		2nd		3rd		4th		5th		6th	
		Add	Data	Add	Data	Add	Data	Add	Data	Add	Data	Add	Data
Enter Extended Block	3	AAA	AA	555	55	AAA	88						
Exit Extended Block	4	AAA	AA	555	55	AAA	90	X	00				

1. X Don't Care. All values in the table are in hexadecimal.
2. Grey cells represent Read cycles. The other cells are Write cycles.

Table 14. Block Protection commands, 16-bit mode

Command	Length	Bus operations ⁽¹⁾⁽²⁾⁽³⁾													
		1st		2nd		3rd		4th		5th		6th		7th	
		Add	Data	Add	Data	Add	Data	Add	Data	Add	Data	Add	Data	Add	Data
Enter Extended Block	3	555	AA	2AA	55	555	88								
Exit Extended Block	4	555	AA	2AA	55	555	90	X	00						

1. Grey cells represent Read cycles. The other cells are Write cycles.
2. X Don't Care. All values in the table are in hexadecimal.
3. During Command cycles, if the lower address bits are 555h or 2AAh then the address bits higher than A11 and data bits higher than DQ7 are Don't Care.

Table 15. Program, Erase Times and Program, Erase Endurance cycles

Parameter		Min	Typ ⁽¹⁾⁽²⁾	Max ⁽²⁾	Unit
Chip Erase			80	400 ⁽³⁾	s
Block Erase (64 KBytes)			0.8	6 ⁽⁴⁾	s
Erase Suspend Latency Time				50 ⁽⁴⁾	µs
Byte Program	Single or Multiple Byte Program (1, 2, 4 or 8 Bytes at-a-time)		10	200 ⁽³⁾	µs
	Write to Buffer and Program (64 Bytes at-a-time)	$V_{PP}/\overline{WP} = V_{PPH}$	90		µs
		$V_{PP}/\overline{WP} = V_{IH}$	280		
Word Program	Single or Multiple Word Program (1, 2 or 4 Words at-a-time)		10	200 ⁽³⁾	µs
	Write to Buffer and Program (32 Words at-a-time)	$V_{PP}/\overline{WP} = V_{PPH}$	90		µs
		$V_{PP}/\overline{WP} = V_{IH}$	280		
Chip Program (Byte by Byte)			80	400 ⁽³⁾	s
Chip Program (Word by Word)			40	200 ⁽³⁾	s
Chip Program (Quadruple Byte or Double Word)			20	100 ⁽³⁾	s
Chip Program (Octuple Byte or Quadruple Word)			10	50 ⁽³⁾	s
Program Suspend Latency Time			5	15	µs
Program/Erase Cycles (per Block)		100,000			cycles
Data Retention		20			years

1. Typical values measured at room temperature and nominal voltages.
2. Sampled, but not 100% tested.
3. Maximum value measured at worst case conditions for both temperature and V_{CC} after 100,00 program/erase cycles.
4. Maximum value measured at worst case conditions for both temperature and V_{CC} .

6 Status register

The M29W128F has one Status Register. The Status Register provides information on the current or previous Program or Erase operations. The various bits convey information and errors on the operation. Bus Read operations from any address within the memory, always read the Status Register during Program and Erase operations. It is also read during Erase Suspend when an address within a block being erased is accessed.

The bits in the Status Register are summarized in *Table 16: Status register bits*.

6.0.1 Data Polling Bit (DQ7)

The Data Polling Bit can be used to identify whether the Program/Erase Controller has successfully completed its operation or if it has responded to an Erase Suspend. The Data Polling Bit is output on DQ7 when the Status Register is read.

During Program operations the Data Polling Bit outputs the complement of the bit being programmed to DQ7. After successful completion of the Program operation the memory returns to Read mode and Bus Read operations from the address just programmed output DQ7, not its complement.

During Erase operations the Data Polling Bit outputs '0', the complement of the erased state of DQ7. After successful completion of the Erase operation the memory returns to Read mode.

In Erase Suspend mode the Data Polling Bit will output a '1' during a Bus Read operation within a block being erased. The Data Polling Bit will change from a '0' to a '1' when the Program/Erase Controller has suspended the Erase operation.

Figure 5: Data Polling flowchart, gives an example of how to use the Data Polling Bit. A Valid Address is the address being programmed or an address within the block being erased.

6.0.2 Toggle Bit (DQ6)

The Toggle Bit can be used to identify whether the Program/Erase Controller has successfully completed its operation or if it has responded to an Erase Suspend. The Toggle Bit is output on DQ6 when the Status Register is read.

During a Program/Erase operation the Toggle Bit changes from '0' to '1' to '0', etc., with successive Bus Read operations at any address. After successful completion of the operation the memory returns to Read mode.

During Erase Suspend mode the Toggle Bit will output when addressing a cell within a block being erased. The Toggle Bit will stop toggling when the Program/Erase Controller has suspended the Erase operation.

Figure 6: Toggle flowchart, gives an example of how to use the Data Toggle Bit.

6.0.3 Error Bit (DQ5)

The Error Bit can be used to identify errors detected by the Program/Erase Controller. The Error Bit is set to '1' when a Program, Block Erase or Chip Erase operation fails to write the correct data to the memory. If the Error Bit is set a Read/Reset command must be issued before other commands are issued. The Error bit is output on DQ5 when the Status Register is read.

Note that the Program command cannot change a bit set to '0' back to '1' and attempting to do so will set DQ5 to '1'. A Bus Read operation to that address will show the bit is still '0'. One of the Erase commands must be used to set all the bits in a block or in the whole memory from '0' to '1'.

6.0.4 Erase Timer Bit (DQ3)

The Erase Timer Bit can be used to identify the start of Program/Erase Controller operation during a Block Erase command. Once the Program/Erase Controller starts erasing the Erase Timer Bit is set to '1'. Before the Program/Erase Controller starts the Erase Timer Bit is set to '0' and additional blocks to be erased may be written to the Command Interface. The Erase Timer Bit is output on DQ3 when the Status Register is read.

6.0.5 Alternative Toggle Bit (DQ2)

The Alternative Toggle Bit can be used to monitor the Program/Erase controller during Erase operations. The Alternative Toggle Bit is output on DQ2 when the Status Register is read.

During Chip Erase and Block Erase operations the Toggle Bit changes from '0' to '1' to '0', etc., with successive Bus Read operations from addresses within the blocks being erased. A protected block is treated the same as a block not being erased. Once the operation completes the memory returns to Read mode.

During Erase Suspend the Alternative Toggle Bit changes from '0' to '1' to '0', etc. with successive Bus Read operations from addresses within the blocks being erased. Bus Read operations to addresses within blocks not being erased will output the memory array data as if in Read mode.

After an Erase operation that causes the Error Bit to be set, the Alternative Toggle Bit can be used to identify which block or blocks have caused the error. The Alternative Toggle Bit changes from '0' to '1' to '0', etc. with successive Bus Read Operations from addresses within blocks that have not erased correctly. The Alternative Toggle Bit does not change if the addressed block has erased correctly.

6.0.6 Write to Buffer and Program Abort Bit (DQ1)

The Write to Buffer and Program Abort bit, DQ1, is set to '1' when a Write to Buffer and Program operation aborts. The Write to Buffer and Program Abort and Reset command must be issued to return the device to Read mode (see Write to Buffer and Program in COMMANDS section).

Table 16. Status register bits⁽¹⁾

Operation	DQ7	DQ6	DQ5	DQ3	DQ2	DQ1	R \bar{B}
Program	$\overline{DQ7}$	Toggle	0	–	–	0	0
Program During Erase Suspend	$\overline{DQ7}$	Toggle	0	–	–	–	0
Write to Buffer and Program Abort	$\overline{DQ7}$	Toggle	0	–	–	1	0
Program Error	$\overline{DQ7}$	Toggle	1	–	–	–	Hi-Z
Chip Erase	0	Toggle	0	1	Toggle	–	0
Block Erase before timeout	0	Toggle	0	0	Toggle	–	0
	0	Toggle	0	0	No Toggle	–	0
Block Erase	0	Toggle	0	1	Toggle	–	0
	0	Toggle	0	1	No Toggle	–	0
Erase Suspend	1	No Toggle	0	–	Toggle	–	Hi-Z
	Data read as normal						–
Erase Error	0	Toggle	1	1	No Toggle	–	Hi-Z
	0	Toggle	1	1	Toggle	–	Hi-Z

1. Unspecified data bits should be ignored.

Figure 5. Data Polling flowchart

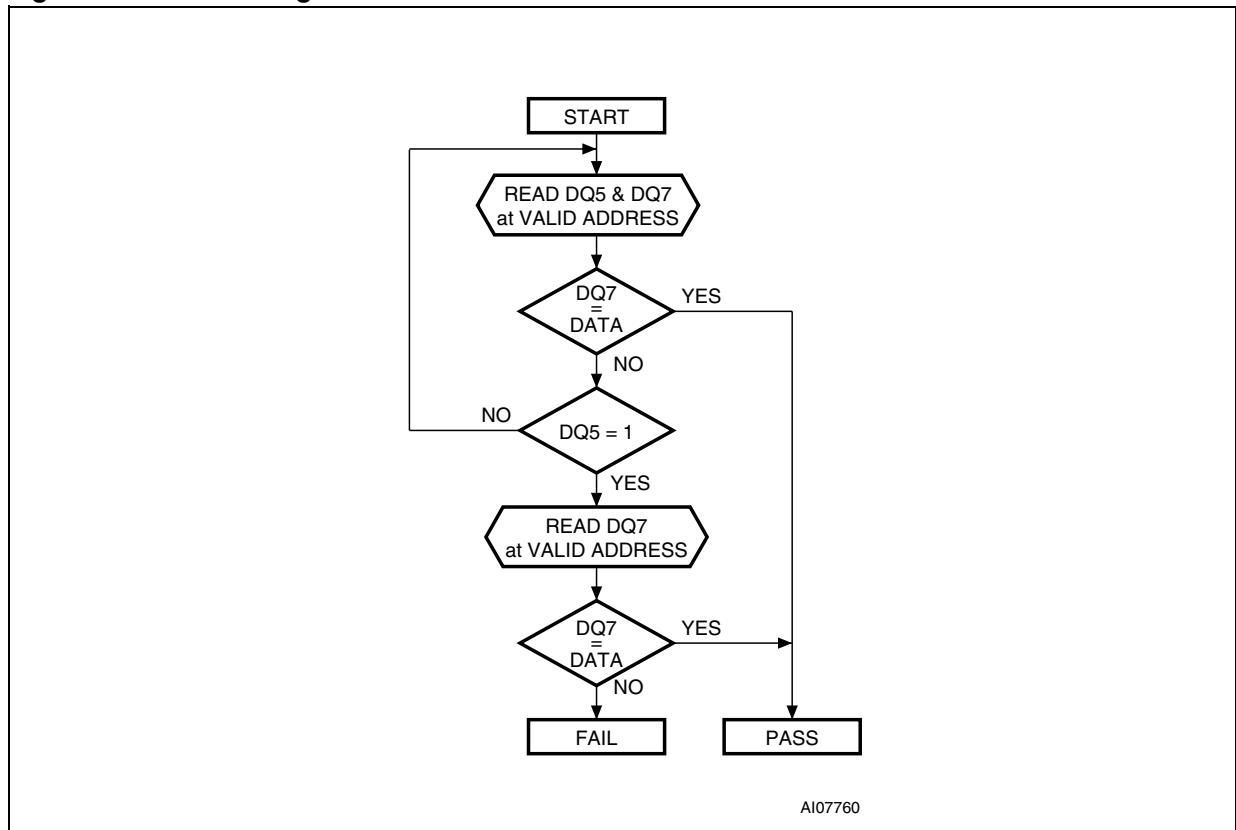
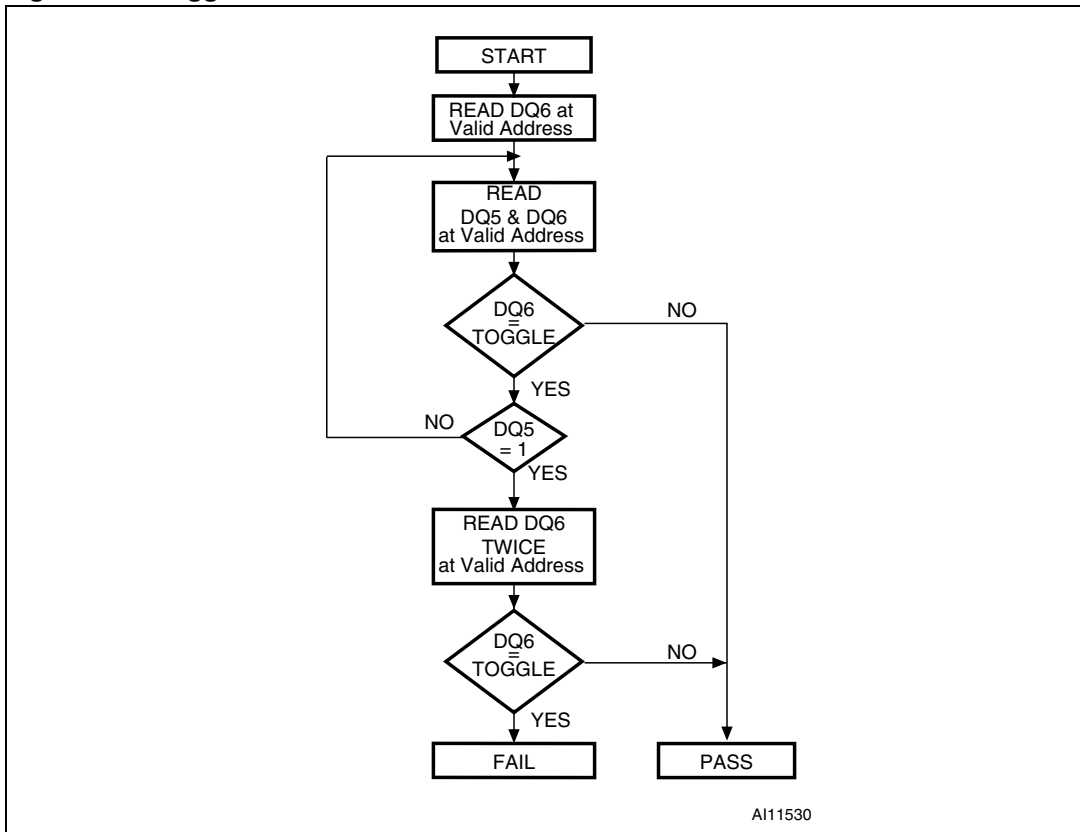

Figure 6. Toggle flowchart



7 Maximum rating

Stressing the device above the rating listed in the Absolute Maximum Ratings table may cause permanent damage to the device. Exposure to Absolute Maximum Rating conditions for extended periods may affect device reliability. These are stress ratings only and operation of the device at these or any other conditions above those indicated in the Operating sections of this specification is not implied. Refer also to the Numonyx SURE Program and other relevant quality documents.

Table 17. Absolute maximum ratings

Symbol	Parameter	Min	Max	Unit
T_{BIAS}	Temperature Under Bias	-50	125	°C
T_{STG}	Storage Temperature	-65	150	°C
V_{IO}	Input or Output voltage ⁽¹⁾⁽²⁾	-0.6	$V_{CC} + 0.6$	V
V_{CC}	Supply voltage	-0.6	4	V
V_{ID}	Identification voltage	-0.6	13.5	V
$V_{PP}^{(3)}$	Program voltage	-0.6	13.5	V

1. Minimum voltage may undershoot to -2V during transition and for less than 20ns during transitions.
2. Maximum voltage may overshoot to $V_{CC} + 2V$ during transition and for less than 20ns during transitions.
3. V_{PP} must not remain at 12V for more than a total of 80hrs.

8 DC and AC parameters

This section summarizes the operating measurement conditions, and the DC and AC characteristics of the device. The parameters in the DC and AC characteristics Tables that follow, are derived from tests performed under the Measurement Conditions summarized in *Table 18: Operating and AC measurement conditions*. Designers should check that the operating conditions in their circuit match the operating conditions when relying on the quoted parameters.

Table 18. Operating and AC measurement conditions

Parameter	M29W128FH, M29W128FL				Unit
	60		70		
	Min	Max	Min	Max	
V _{CC} supply voltage	2.7	3.6	2.7	3.6	V
Ambient Operating Temperature	-40	85	-40	85	°C
Load capacitance (C _L)	30		30		pF
Input Rise and Fall Times		10		10	ns
Input pulse voltages	0 to V _{CC}		0 to V _{CC}		V
Input and Output Timing Ref. voltages	V _{CC} /2		V _{CC} /2		V

Figure 7. AC measurement load circuit

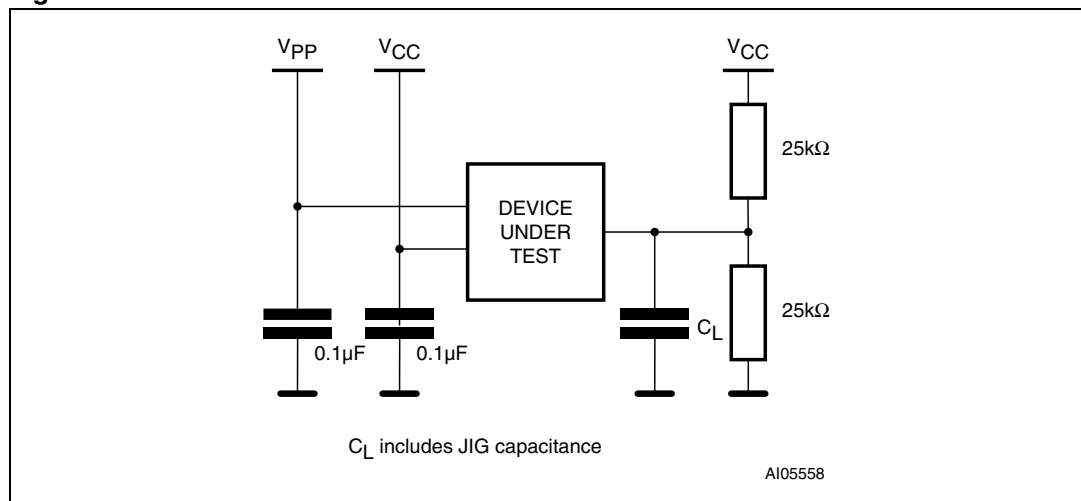
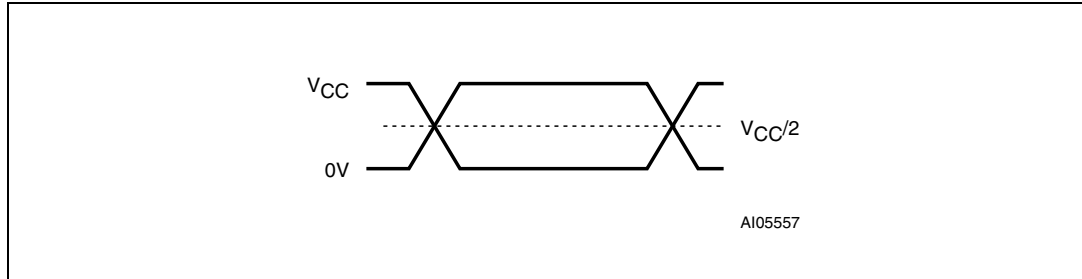

Figure 8. AC measurement I/O waveform**Table 19. Device capacitance⁽¹⁾**

Symbol	Parameter	Test condition	Min	Max	Unit
C_{IN}	Input Capacitance	$V_{IN} = 0V$		6	pF
C_{OUT}	Output Capacitance	$V_{OUT} = 0V$		12	pF

1. Sampled only, not 100% tested.

Table 20. DC characteristics

Symbol	Parameter	Test condition	Min	Max	Unit
I_{LI}	Input Leakage Current	$0V \leq V_{IN} \leq V_{CC}$		± 1	μA
I_{LO}	Output Leakage Current	$0V \leq V_{OUT} \leq V_{CC}$		± 1	μA
I_{CC1}	Supply Current (Read)	$\bar{E} = V_{IL}, \bar{G} = V_{IH},$ $f = 6MHz$		10	mA
I_{CC2}	Supply Current (Standby)	$\bar{E} = V_{CC} \pm 0.2V,$ $\bar{RP} = V_{CC} \pm 0.2V$		100	μA
$I_{CC3}^{(1)}$	Supply Current (Program/Erase)	Program/Erase Controller active	$V_{PP}/\bar{WP} = V_{IL} \text{ or } V_{IH}$	20	mA
			$V_{PP}/\bar{WP} = V_{PPH}$	20	mA
V_{IL}	Input Low voltage		-0.5	0.8	V
V_{IH}	Input High voltage		$0.7V_{CC}$	$V_{CC} + 0.3$	V
V_{PPH}	Voltage for V_{PP}/\bar{WP} Program Acceleration	$V_{CC} = 2.7V \pm 10\%$	11.5	12.5	V
I_{PP}	Current for V_{PP}/\bar{WP} Program Acceleration	$V_{CC} = 2.7V \pm 10\%$		15	mA
V_{OL}	Output Low voltage	$I_{OL} = 1.8mA$		0.45	V
V_{OH}	Output High voltage	$I_{OH} = -100\mu A$	$V_{CC} - 0.4$		V
V_{ID}	Identification voltage		11.5	12.5	V
V_{LKO}	Program/Erase Lockout Supply voltage		1.8	2.3	V

1. Sampled only, not 100% tested.

Figure 9. Random Read AC waveforms

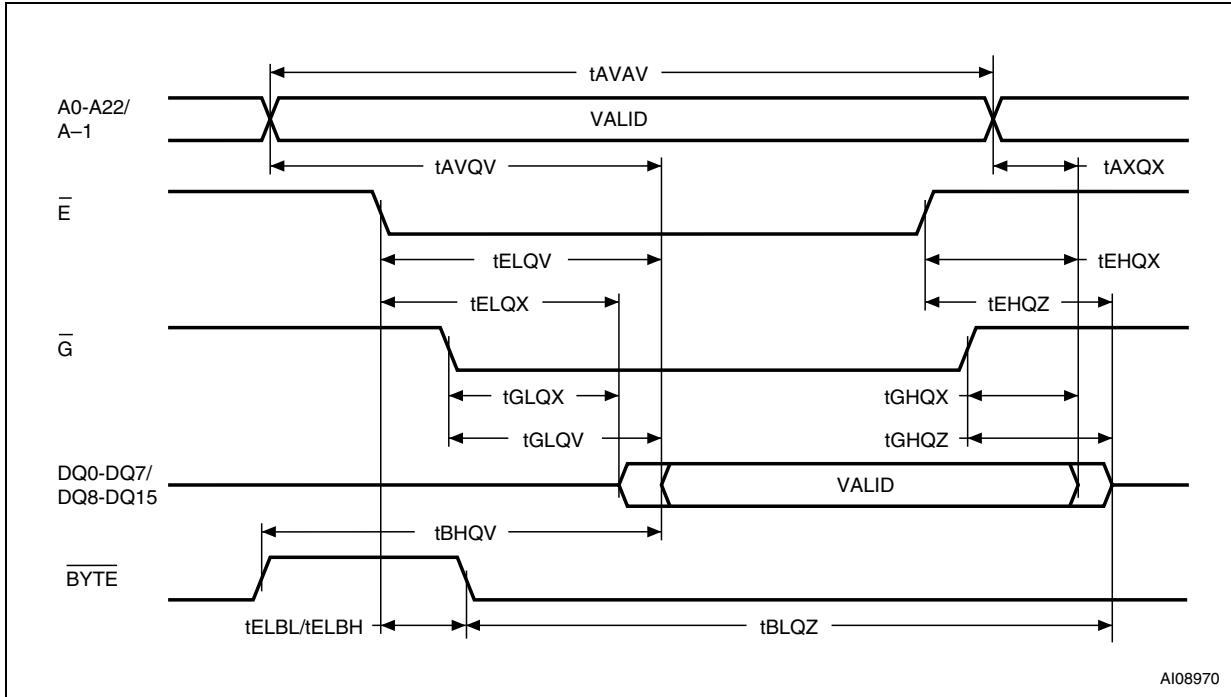

Figure 10. Page Read AC waveforms (Word mode)

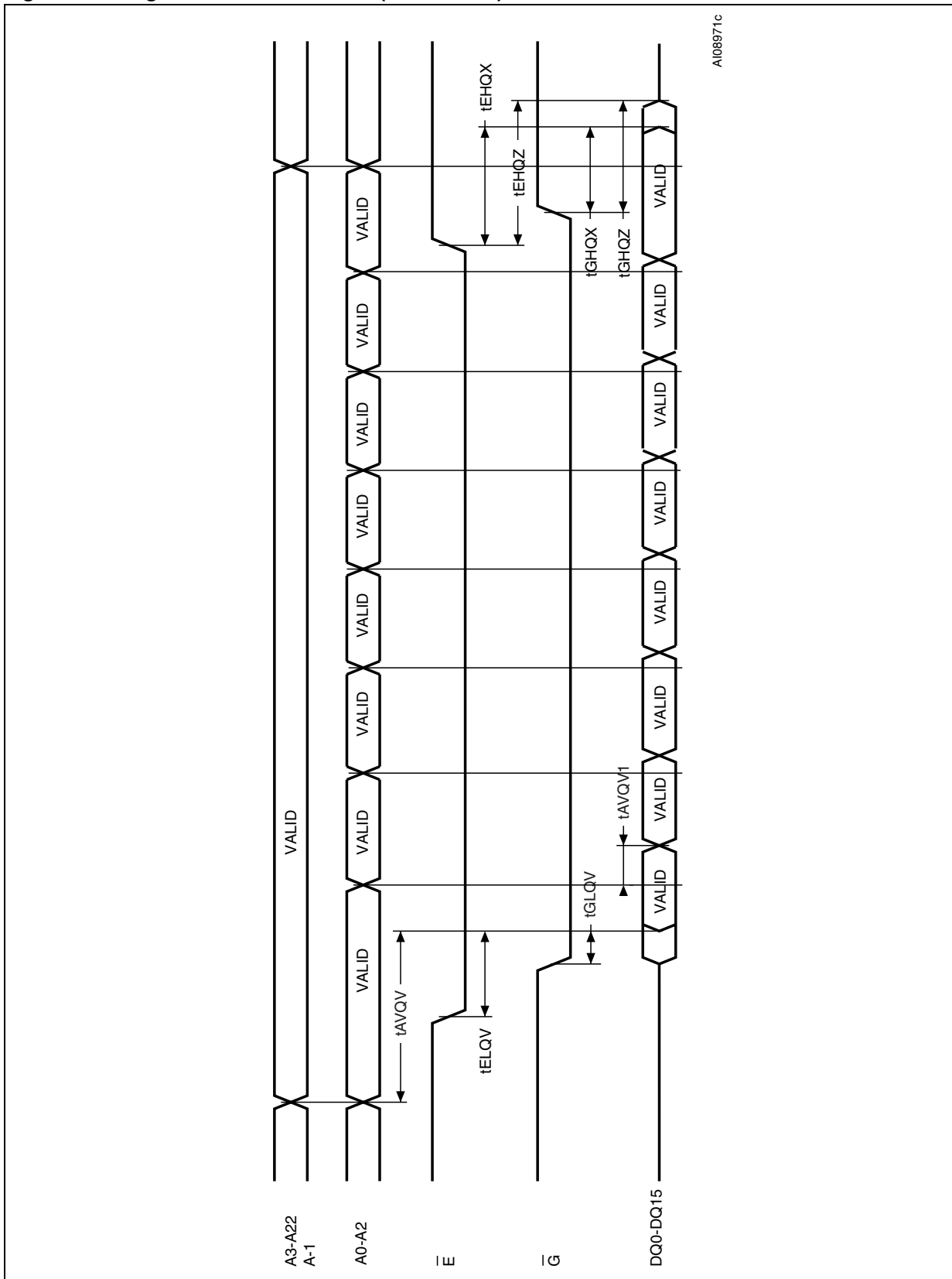

Table 21. Read AC characteristics

Symbol	Alt	Parameter	Test condition		M29W128FH, M29W128FL		Unit
					60	70	
t_{AVAV}	t_{RC}	Address Valid to Next Address Valid	$\overline{E} = V_{IL},$ $\overline{G} = V_{IL}$	Min	60	70	ns
t_{AVQV}	t_{ACC}	Address Valid to Output Valid	$\overline{E} = V_{IL},$ $\overline{G} = V_{IL}$	Max	60	70	ns
t_{AVQV1}	t_{PAGE}	Address Valid to Output Valid (Page)	$\overline{E} = V_{IL},$ $\overline{G} = V_{IL}$	Max	25	30	ns
$t_{ELQX}^{(1)}$	t_{LZ}	Chip Enable Low to Output Transition	$\overline{G} = V_{IL}$	Min	0	0	ns
t_{ELQV}	t_{CE}	Chip Enable Low to Output Valid	$\overline{G} = V_{IL}$	Max	60	70	ns
$t_{GLQX}^{(1)}$	t_{OLZ}	Output Enable Low to Output Transition	$\overline{E} = V_{IL}$	Min	0	0	ns
t_{GLQV}	t_{OE}	Output Enable Low to Output Valid	$\overline{E} = V_{IL}$	Max	20	25	ns
$t_{EHQX}^{(1)}$	t_{HZ}	Chip Enable High to Output Hi-Z	$\overline{G} = V_{IL}$	Max	25	25	ns
$t_{GHQX}^{(1)}$	t_{DF}	Output Enable High to Output Hi-Z	$\overline{E} = V_{IL}$	Max	25	25	ns
t_{EHQX} t_{GHQX} t_{AXQX}	t_{OH}	Chip Enable, Output Enable or Address Transition to Output Transition		Min	0	0	ns
t_{ELBL} t_{ELBH}	t_{ELFL} t_{ELFH}	Chip Enable to \overline{BYTE} Low or High		Max	5	5	ns
t_{BLQZ}	t_{FLQZ}	\overline{BYTE} Low to Output Hi-Z		Max	25	25	ns
t_{BHQV}	t_{FHQV}	\overline{BYTE} High to Output Valid		Max	30	30	ns

1. Sampled only, not 100% tested.

Figure 11. Write AC waveforms, Write Enable Controlled

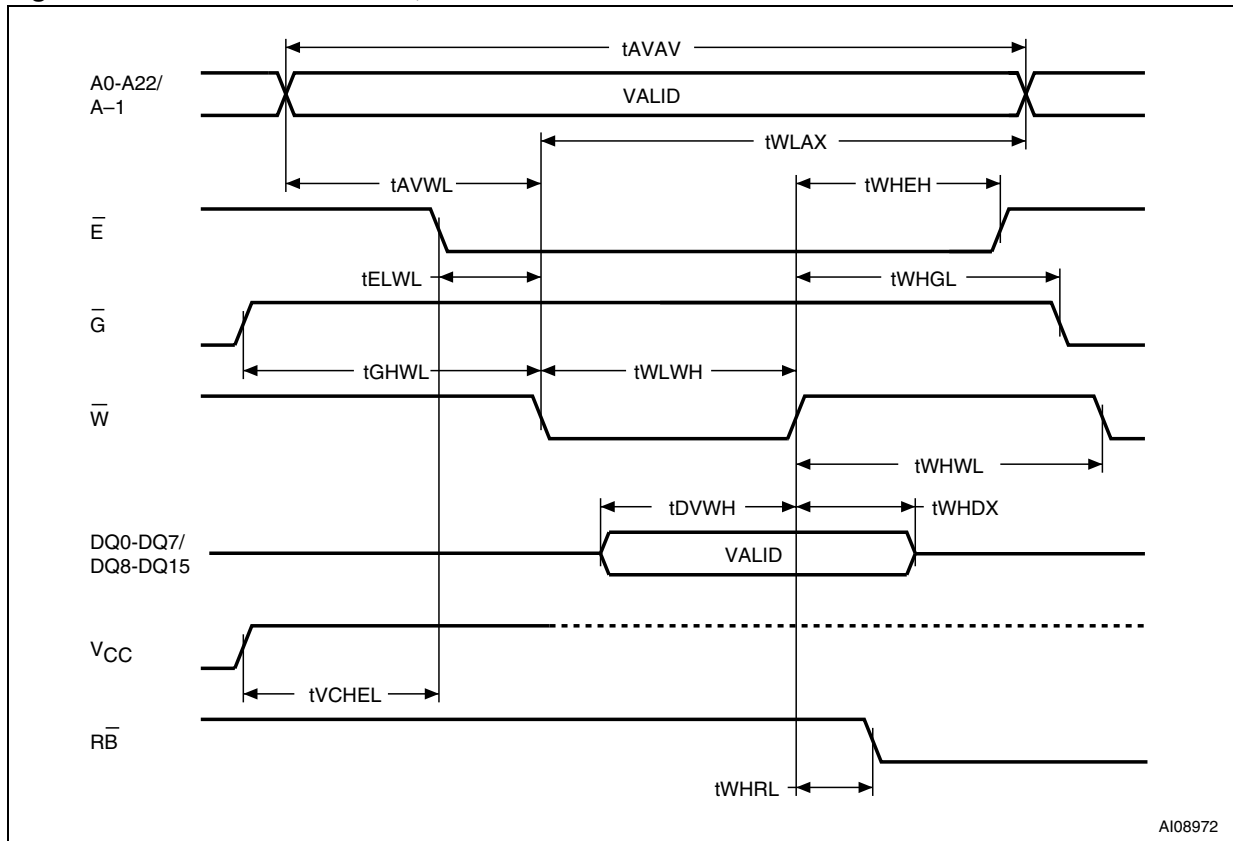

Table 22. Write AC characteristics, Write Enable Controlled

Symbol	Alt	Parameter		M29W128FH, M29W128FL		Unit
				60	70	
t_{AVAV}	t_{WC}	Address Valid to Next Address Valid	Min	60	70	ns
t_{ELWL}	t_{CS}	Chip Enable Low to Write Enable Low	Min	0	0	ns
t_{WLWH}	t_{WP}	Write Enable Low to Write Enable High	Min	45	45	ns
t_{DVWH}	t_{DS}	Input Valid to Write Enable High	Min	45	45	ns
t_{WHDX}	t_{DH}	Write Enable High to Input Transition	Min	0	0	ns
t_{WHEH}	t_{CH}	Write Enable High to Chip Enable High	Min	0	0	ns
t_{WHWL}	t_{WPH}	Write Enable High to Write Enable Low	Min	30	30	ns
t_{AVWL}	t_{AS}	Address Valid to Write Enable Low	Min	0	0	ns
t_{WLAX}	t_{AH}	Write Enable Low to Address Transition	Min	45	45	ns
t_{GHWL}		Output Enable High to Write Enable Low	Min	0	0	ns
t_{WHGL}	t_{OEHL}	Write Enable High to Output Enable Low	Min	0	0	ns
$t_{WHRL}^{(1)}$	t_{BUSY}	Program/Erase Valid to \overline{RB} Low	Max	30	30	ns
t_{VCHL}	t_{VCS}	V_{CC} High to Chip Enable Low	Min	50	50	μ s

1. Sampled only, not 100% tested.

Figure 12. Write AC waveforms, Chip Enable Controlled

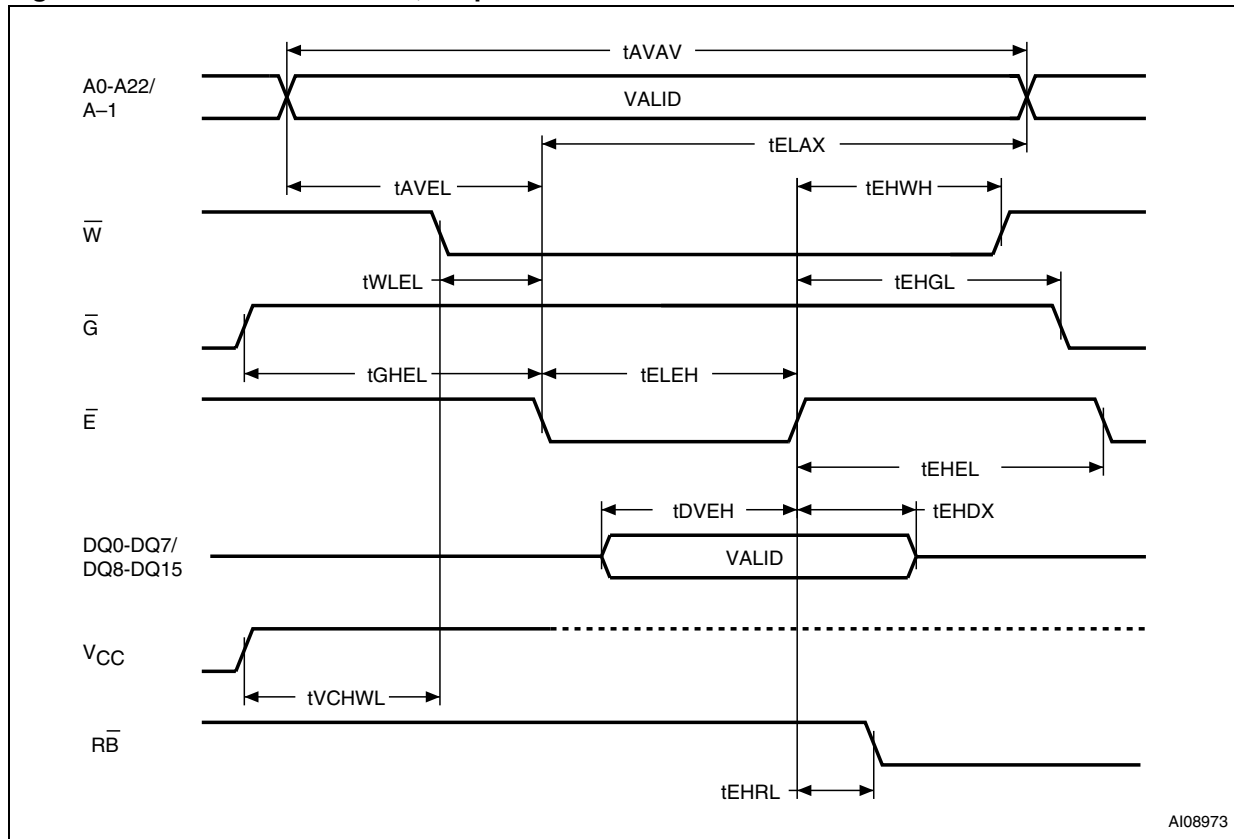

Table 23. Write AC characteristics, Chip Enable Controlled

Symbol	Alt	Parameter	Min	M29W128FH, M29W128FL		Unit
				60	70	
t _{AVAV}	t _{WC}	Address Valid to Next Address Valid	Min	60	70	ns
t _{WLEL}	t _{WS}	Write Enable Low to Chip Enable Low	Min	0	0	ns
t _{ELEH}	t _{CP}	Chip Enable Low to Chip Enable High	Min	45	45	ns
t _{DVEH}	t _{DS}	Input Valid to Chip Enable High	Min	45	45	ns
t _{EHDX}	t _{DH}	Chip Enable High to Input Transition	Min	0	0	ns
t _{EHWH}	t _{WH}	Chip Enable High to Write Enable High	Min	0	0	ns
t _{EHEL}	t _{CPH}	Chip Enable High to Chip Enable Low	Min	30	30	ns
t _{AVEL}	t _{AS}	Address Valid to Chip Enable Low	Min	0	0	ns
t _{ELAX}	t _{AH}	Chip Enable Low to Address Transition	Min	45	45	ns
t _{GHEL}		Output Enable High Chip Enable Low	Min	0	0	ns
t _{EHGL}	t _{OEHL}	Chip Enable High to Output Enable Low	Min	0	0	ns
t _{EHRL} ⁽¹⁾	t _{BUSY}	Program/Erase Valid to RB-bar Low	Max	30	30	ns
t _{VCHWL}	t _{VCS}	V _{CC} High to Write Enable Low	Min	50	50	µs

1. Sampled only, not 100% tested.

Figure 13. Reset/Block Temporary Unprotect AC waveforms (No Program/Erase ongoing)

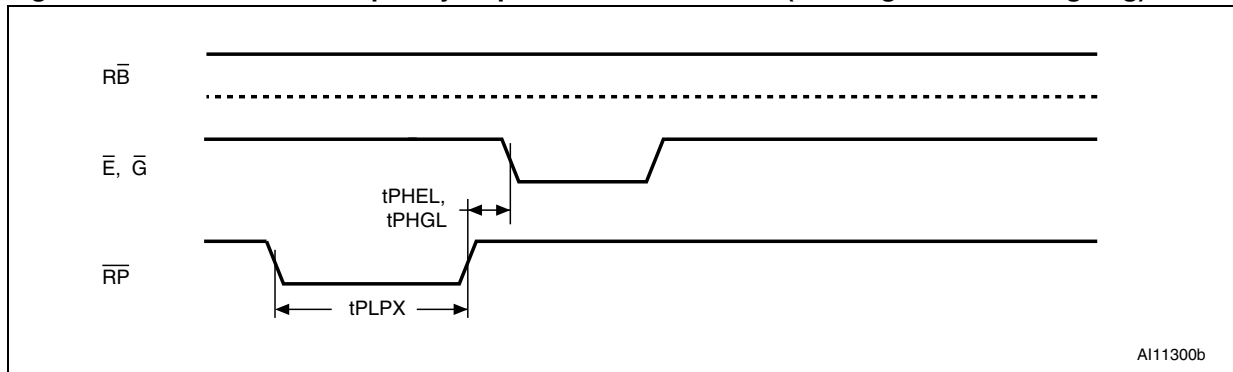

Figure 14. Reset/Block Temporary Unprotect during Program/Erase operation AC waveforms

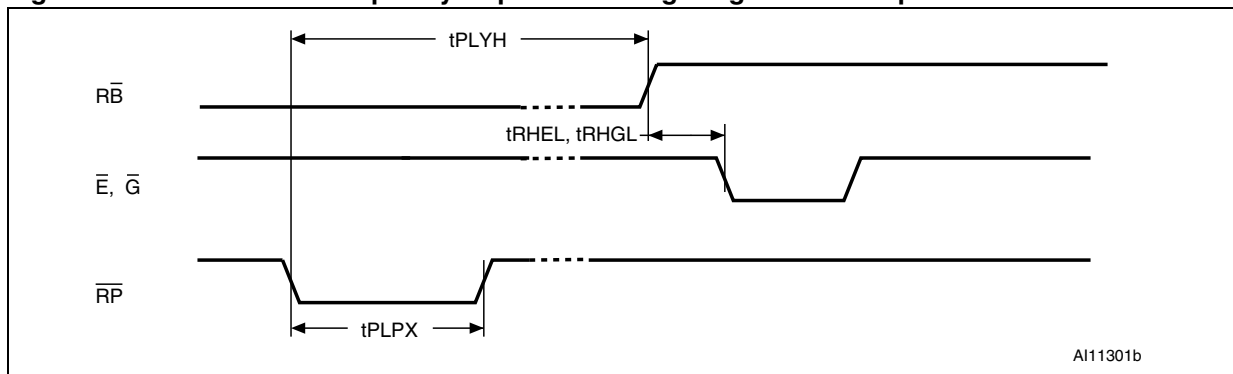
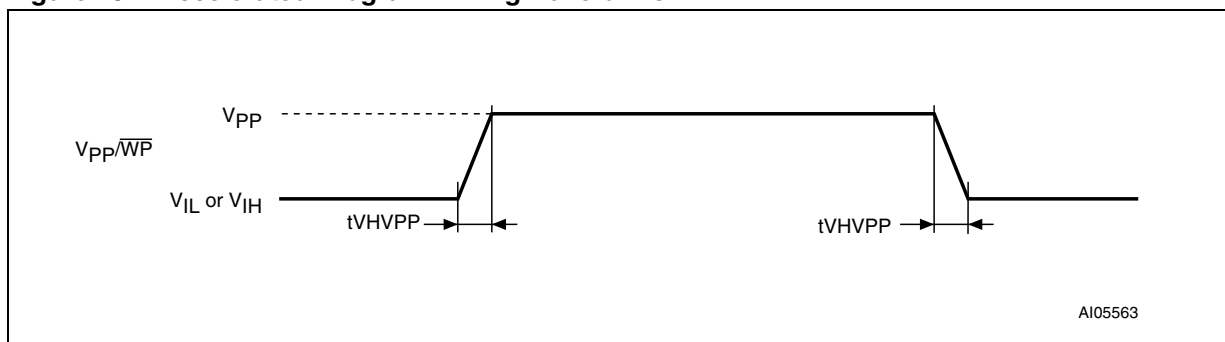

Table 24. Reset/Block Temporary Unprotect AC characteristics

Symbol	Alt	Parameter		M29W128FH, M29W128FL		Unit
				60	70	
$t_{PLYH}^{(1)}$	t_{READY}	\overline{RP} Low to Read mode, during Program or Erase	Max	20		μs
t_{PLPX}	t_{RP}	\overline{RP} Pulse Width	Min	500		ns
$t_{PHEL}, t_{PHGL}^{(1)}$	t_{RH}	\overline{RP} High to Write Enable Low, Chip Enable Low, Output Enable Low	Min	50		ns
	t_{RPD}	\overline{RP} Low to Standby Mode.	Min	20		ns
$t_{RHEL}, t_{RHGL}^{(1)}$	t_{RB}	\overline{RB} High to Write Enable Low, Chip Enable Low, Output Enable Low	Min	0		ns

1. Sampled only, not 100% tested.

Figure 15. Accelerated Program Timing waveforms



9 Package mechanical

Figure 16. TSOP56 – 56 lead Plastic Thin Small Outline, 14 x 20mm, package outline

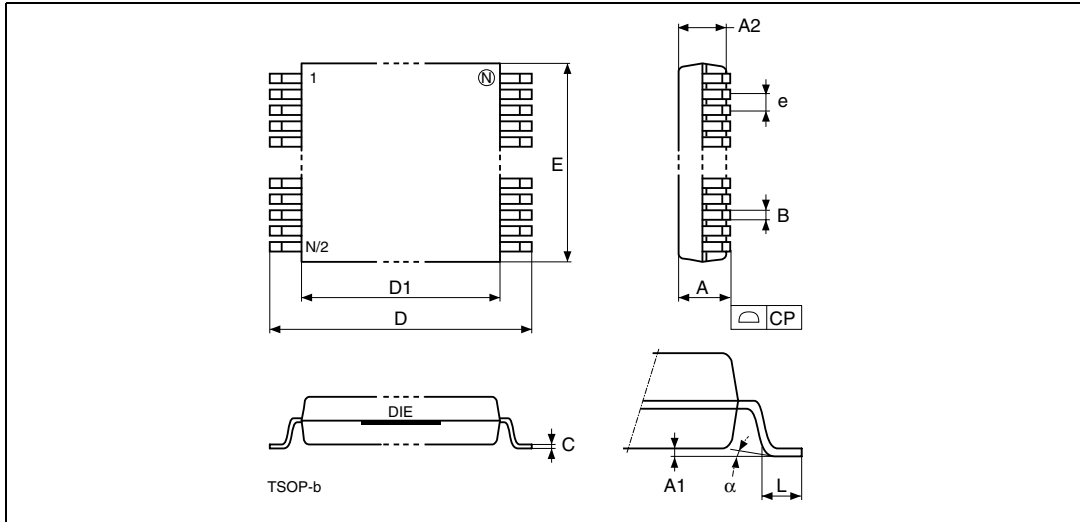

1. Drawing is not to scale.

Table 25. TSOP56 – 56 lead Plastic Thin Small Outline, 14 x 20mm, package mechanical data

Symbol	millimeters			inches		
	Typ	Min	Max	Typ	Min	Max
A			1.200			0.0472
A1	0.100	0.050	0.150	0.0039	0.0020	0.0059
A2	1.000	0.950	1.050	0.0394	0.0374	0.0413
B	0.220	0.170	0.270	0.0087	0.0067	0.0106
C		0.100	0.210		0.0039	0.0083
CP			0.100			0.0039
D	20.000	19.800	20.200	0.7874	0.7795	0.7953
D1	18.400	18.300	18.500	0.7244	0.7205	0.7283
e	0.500	–	–	0.0197	–	–
E	14.000	13.900	14.100	0.5512	0.5472	0.5551
L	0.600	0.500	0.700	0.0236	0.0197	0.0276
α	3°	0	5°	3°	0	5°
N	56			56		

Figure 17. TBGA64 10x13mm - 8x8 active ball array, 1mm pitch, package outline

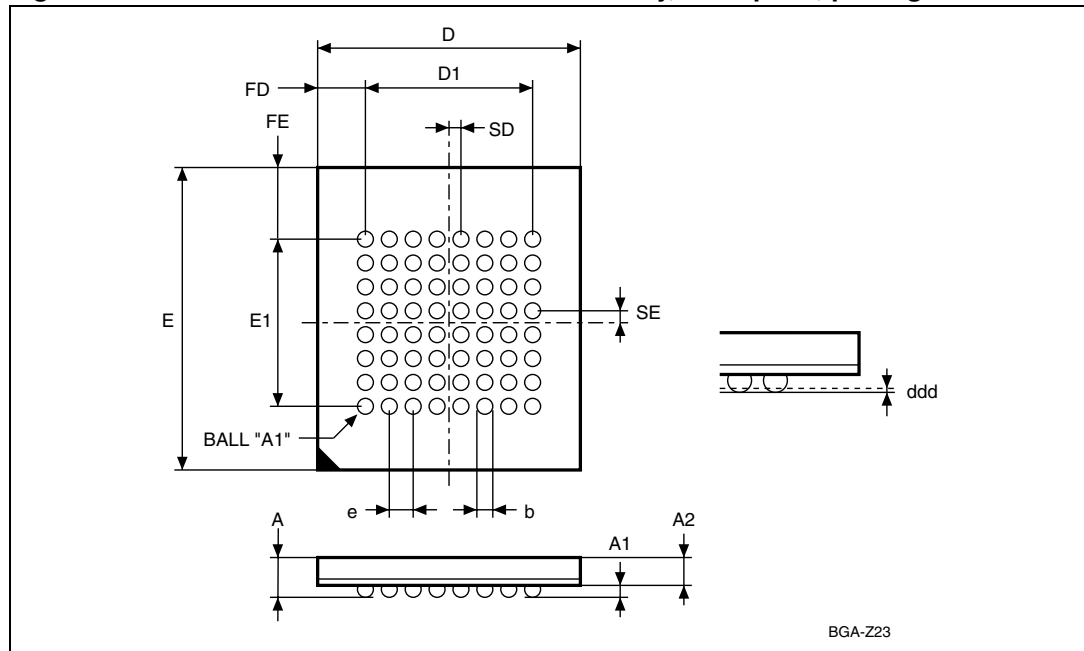

1. Drawing is not to scale.

Table 26. TBGA64 10x13mm - 8x8 active ball array, 1mm pitch, package mechanical data

Symbol	millimeters			inches		
	Typ	Min	Max	Typ	Min	Max
A			1.200			0.0472
A1	0.300	0.200	0.350	0.0118	0.0079	0.0138
A2	0.800			0.0315		
b		0.350	0.500		0.0138	0.0197
D	10.000	9.900	10.100	0.3937	0.3898	0.3976
D1	7.000	-	-	0.2756	-	-
ddd			0.100			0.0039
e	1.000	-	-	0.0394	-	-
E	13.000	12.900	13.100	0.5118	0.5079	0.5157
E1	7.000	-	-	0.2756	-	-
FD	1.500	-	-	0.0591	-	-
FE	3.000	-	-	0.1181	-	-
SD	0.500	-	-	0.0197	-	-
SE	0.500	-	-	0.0197	-	-

10 Part numbering

Table 27. Ordering information scheme

Example:	M29W128FH 70 N 6 F
Device type	
M29	
Operating voltage	
W = $V_{CC} = 2.7$ to $3.6V$	
Device function	
128FH = 128 Mbit (x8/x16), Page, Uniform Block, Flash Memory, Highest Block Protected by V_{PP}/\overline{WP}	
128FL = 128 Mbit (x8/x16), Page, Uniform Block, Flash Memory, Lowest Block Protected by V_{PP}/\overline{WP}	
Speed	
60 = 60ns	
70 = 70ns	
Package	
N = TSOP56: 14 x 20 mm	
ZA = TBGA64: 10 x13mm, 1mm pitch	
Temperature range	
6 = -40 to 85 °C	
Option	
E = ECOPACK Package, Standard Packing	
F = ECOPACK Package, Tape & Reel Packing	

Note: This product is also available with the Extended Memory Block factory locked. For further details and ordering information contact your nearest Numonyx sales office.

Devices are shipped from the factory with the memory content bits erased to '1'.

For a list of available options (Speed, Package, etc.) or for further information on any aspect of this device, please contact your nearest Numonyx Sales Office.

Appendix A Block addresses and Read/Modify Protection Groups

Table 28. Block Addresses and Protection Groups

Block	Size (KBytes/KWords)	Protection Block Group	(x8)	(x16)
0	64/32	Protection Group	000000h-00FFFFh	000000h-007FFFh
1	64/32	Protection Group	010000h-01FFFFh	008000h-00FFFFh
2	64/32	Protection Group	020000h-02FFFFh	010000h-017FFFh
3	64/32	Protection Group	030000h-03FFFFh	018000h-01FFFFh
4	64/32	Protection Group	040000h-04FFFFh	020000h-027FFFh
5	64/32		050000h-05FFFFh	028000h-02FFFFh
6	64/32		060000h-06FFFFh	030000h-037FFFh
7	64/32		070000h-07FFFFh	038000h-03FFFFh
8	64/32	Protection Group	080000h-08FFFFh	040000h-047FFFh
9	64/32		090000h-09FFFFh	048000h-04FFFFh
10	64/32		0A0000h-0AFFFFh	050000h-057FFFh
11	64/32		0B0000h-0BFFFFh	058000h-05FFFFh
12	64/32	Protection Group	0C0000h-0CFFFFh	060000h-067FFFh
13	64/32		0D0000h-0DFFFFh	068000h-06FFFFh
14	64/32		0E0000h-0EFFFFh	070000h-077FFFh
15	64/32		0F0000h-0FFFFFFh	078000h-07FFFFh
16	64/32	Protection Group	100000h-10FFFFh	080000h-087FFFh
17	64/32		110000h-11FFFFh	088000h-08FFFFh
18	64/32		120000h-12FFFFh	090000h-097FFFh
19	64/32		130000h-13FFFFh	098000h-09FFFFh
20	64/32	Protection Group	140000h-14FFFFh	0A0000h-0A7FFFh
21	64/32		150000h-15FFFFh	0A8000h-0AFFFFh
22	64/32		160000h-16FFFFh	0B0000h-0B7FFFh
23	64/32		170000h-17FFFFh	0B8000h-0BFFFFh
24	64/32	Protection Group	180000h-18FFFFh	0C0000h-0C7FFFh
25	64/32		190000h-19FFFFh	0C8000h-0CFFFFh
26	64/32		1A0000h-1AFFFFh	0D0000h-0D7FFFh
27	64/32		1B0000h-1BFFFFh	0D8000h-0DFFFFh

Table 28. Block Addresses and Protection Groups (continued)

Block	Size (KBytes/KWords)	Protection Block Group	(x8)	(x16)
28	64/32	Protection Group	1C0000h-1CFFFFh	0E0000h-0E7FFFh
29	64/32		1D0000h-1DFFFFh	0E8000h-0EFFFFh
30	64/32		1E0000h-1EFFFFh	0F0000h-0F7FFFh
31	64/32		1F0000h-1FFFFFFh	0F8000h-0FFFFFFh
32	64/32	Protection Group	200000h-20FFFFh	100000h-107FFFh
33	64/32		210000h-21FFFFh	108000h-10FFFFh
34	64/32		220000h-22FFFFh	110000h-117FFFh
35	64/32		230000h-23FFFFh	118000h-11FFFFh
36	64/32	Protection Group	240000h-24FFFFh	120000h-127FFFh
37	64/32		250000h-25FFFFh	128000h-12FFFFh
38	64/32		260000h-26FFFFh	130000h-137FFFh
39	64/32		270000h-27FFFFh	138000h-13FFFFh
40	64/32	Protection Group	280000h-28FFFFh	140000h-147FFFh
41	64/32		290000h-29FFFFh	148000h-14FFFFh
42	64/32		2A0000h-2AFFFFh	150000h-157FFFh
43	64/32		2B0000h-2BFFFFh	158000h-15FFFFh
44	64/32	Protection Group	2C0000h-2CFFFFh	160000h-167FFFh
45	64/32		2D0000h-2DFFFFh	168000h-16FFFFh
46	64/32		2E0000h-2EFFFFh	170000h-177FFFh
47	64/32		2F0000h-2FFFFFFh	178000h-17FFFFh
48	64/32	Protection Group	300000h-30FFFFh	180000h-187FFFh
49	64/32		310000h-31FFFFh	188000h-18FFFFh
50	64/32		320000h-32FFFFh	190000h-197FFFh
51	64/32		330000h-33FFFFh	198000h-19FFFFh
52	64/32	Protection Group	340000h-34FFFFh	1A0000h-1A7FFFh
53	64/32		350000h-35FFFFh	1A8000h-1AFFFFh
54	64/32		360000h-36FFFFh	1B0000h-1B7FFFh
55	64/32		370000h-37FFFFh	1B8000h-1BFFFFh
56	64/32	Protection Group	380000h-38FFFFh	1C0000h-1C7FFFh
57	64/32		390000h-39FFFFh	1C8000h-1CFFFFh
58	64/32		3A0000h-3AFFFFh	1D0000h-1D7FFFh
59	64/32		3B0000h-3BFFFFh	1D8000h-1DFFFFh

Table 28. Block Addresses and Protection Groups (continued)

Block	Size (KBytes/KWords)	Protection Block Group	(x8)	(x16)
60	64/32	Protection Group	3C0000h-3CFFFFh	1E0000h-1E7FFFh
61	64/32		3D0000h-3DFFFFh	1E8000h-1EFFFFh
62	64/32		3E0000h-3EFFFFh	1F0000h-1F7FFFh
63	64/32		3F0000h-3FFFFFFh	1F8000h-1FFFFFFh
64	64/32	Protection Group	400000h-40FFFFh	200000h-207FFFh
65	64/32		410000h-41FFFFh	208000h-20FFFFh
66	64/32		420000h-42FFFFh	210000h-217FFFh
67	64/32		430000h-43FFFFh	218000h-21FFFFh
68	64/32	Protection Group	440000h-44FFFFh	220000h-227FFFh
69	64/32		450000h-45FFFFh	228000h-22FFFFh
70	64/32		460000h-46FFFFh	230000h-237FFFh
71	64/32		470000h-47FFFFh	238000h-23FFFFh
72	64/32	Protection Group	480000h-48FFFFh	240000h-247FFFh
73	64/32		490000h-49FFFFh	248000h-24FFFFh
74	64/32		4A0000h-4AFFFFh	250000h-257FFFh
75	64/32		4B0000h-4BFFFFh	258000h-25FFFFh
76	64/32	Protection Group	4C0000h-4CFFFFh	260000h-267FFFh
77	64/32		4D0000h-4DFFFFh	268000h-26FFFFh
78	64/32		4E0000h-4EFFFFh	270000h-277FFFh
79	64/32		4F0000h-4FFFFFFh	278000h-27FFFFh
80	64/32	Protection Group	500000h-50FFFFh	280000h-287FFFh
81	64/32		510000h-51FFFFh	288000h-28FFFFh
82	64/32		520000h-52FFFFh	290000h-297FFFh
83	64/32		530000h-53FFFFh	298000h-29FFFFh
84	64/32	Protection Group	540000h-54FFFFh	2A0000h-2A7FFFh
85	64/32		550000h-55FFFFh	2A8000h-2AFFFFh
86	64/32		560000h-56FFFFh	2B0000h-2B7FFFh
87	64/32		570000h-57FFFFh	2B8000h-2BFFFFh
88	64/32	Protection Group	580000h-58FFFFh	2C0000h-2C7FFFh
89	64/32		590000h-59FFFFh	2C8000h-2CFFFFh
90	64/32		5A0000h-5AFFFFh	2D0000h-2D7FFFh
91	64/32		5B0000h-5BFFFFh	2D8000h-2DFFFFh

Table 28. Block Addresses and Protection Groups (continued)

Block	Size (KBytes/KWords)	Protection Block Group	(x8)	(x16)
92	64/32	Protection Group	5C0000h-5CFFFFh	2E0000h-2E7FFFh
93	64/32		5D0000h-5DFFFFh	2E8000h-2EFFFFh
94	64/32		5E0000h-5EFFFFh	2F0000h-2F7FFFh
95	64/32		5F0000h-5FFFFFFh	2F8000h-2FFFFFFh
96	64/32	Protection Group	600000h-60FFFFh	300000h-307FFFh
97	64/32		610000h-61FFFFh	308000h-30FFFFh
98	64/32		620000h-62FFFFh	310000h-317FFFh
99	64/32		630000h-63FFFFh	318000h-31FFFFh
100	64/32	Protection Group	640000h-64FFFFh	320000h-327FFFh
101	64/32		650000h-65FFFFh	328000h-32FFFFh
102	64/32		660000h-66FFFFh	330000h-337FFFh
103	64/32		670000h-67FFFFh	338000h-33FFFFh
104	64/32	Protection Group	680000h-68FFFFh	340000h-347FFFh
105	64/32		690000h-69FFFFh	348000h-34FFFFh
106	64/32		6A0000h-6AFFFFh	350000h-357FFFh
107	64/32		6B0000h-6BFFFFh	358000h-35FFFFh
108	64/32	Protection Group	6C0000h-6CFFFFh	360000h-367FFFh
109	64/32		6D0000h-6DFFFFh	368000h-36FFFFh
110	64/32		6E0000h-6EFFFFh	370000h-377FFFh
111	64/32		6F0000h-6FFFFFFh	378000h-37FFFFh
112	64/32	Protection Group	700000h-70FFFFh	380000h-387FFFh
113	64/32		710000h-71FFFFh	388000h-38FFFFh
114	64/32		720000h-72FFFFh	390000h-397FFFh
115	64/32		730000h-73FFFFh	398000h-39FFFFh
116	64/32	Protection Group	740000h-74FFFFh	3A0000h-3A7FFFh
117	64/32		750000h-75FFFFh	3A8000h-3AFFFFh
118	64/32		760000h-76FFFFh	3B0000h-3B7FFFh
119	64/32		770000h-77FFFFh	3B8000h-3BFFFFh
120	64/32	Protection Group	780000h-78FFFFh	3C0000h-3C7FFFh
121	64/32		790000h-79FFFFh	3C8000h-3CFFFFh
122	64/32		7A0000h-7AFFFFh	3D0000h-3D7FFFh
123	64/32		7B0000h-7BFFFFh	3D8000h-3DFFFFh

Table 28. Block Addresses and Protection Groups (continued)

Block	Size (KBytes/KWords)	Protection Block Group	(x8)	(x16)
124	64/32	Protection Group	7C0000h–7CFFFFh	3E0000h–3E7FFFh
125	64/32		7D0000h–7DFFFFh	3E8000h–3EFFFFh
126	64/32		7E0000h–7EFFFFh	3F0000h–3F7FFFh
127	64/32		7F0000h–7FFFFFFh	3F8000h–3FFFFFFh
128	64/32	Protection Group	800000h–80FFFFh	400000h–407FFFh
129	64/32		810000h–81FFFFh	408000h–40FFFFh
130	64/32		820000h–82FFFFh	410000h–417FFFh
131	64/32		830000h–83FFFFh	418000h–41FFFFh
132	64/32	Protection Group	840000h–84FFFFh	420000h–427FFFh
133	64/32		850000h–85FFFFh	428000h–42FFFFh
134	64/32		860000h–86FFFFh	430000h–437FFFh
135	64/32		870000h–87FFFFh	438000h–43FFFFh
136	64/32	Protection Group	880000h–88FFFFh	440000h–447FFFh
137	64/32		890000h–89FFFFh	448000h–44FFFFh
138	64/32		8A0000h–8AFFFFh	450000h–457FFFh
139	64/32		8B0000h–8BFFFFh	458000h–45FFFFh
140	64/32	Protection Group	8C0000h–8CFFFFh	460000h–467FFFh
141	64/32		8D0000h–8DFFFFh	468000h–46FFFFh
142	64/32		8E0000h–8EFFFFh	470000h–477FFFh
143	64/32		8F0000h–8FFFFFFh	478000h–47FFFFh
144	64/32	Protection Group	900000h–90FFFFh	480000h–487FFFh
145	64/32		910000h–91FFFFh	488000h–48FFFFh
146	64/32		920000h–92FFFFh	490000h–497FFFh
147	64/32		930000h–93FFFFh	498000h–49FFFFh
148	64/32	Protection Group	940000h–94FFFFh	4A0000h–4A7FFFh
149	64/32		950000h–95FFFFh	4A8000h–4AFFFFh
150	64/32		960000h–96FFFFh	4B0000h–4B7FFFh
151	64/32		970000h–97FFFFh	4B8000h–4BFFFFh
152	64/32	Protection Group	980000h–98FFFFh	4C0000h–4C7FFFh
153	64/32		990000h–99FFFFh	4C8000h–4CFFFFh
154	64/32		9A0000h–9AFFFFh	4D0000h–4D7FFFh
155	64/32		9B0000h–9BFFFFh	4D8000h–4DFFFFh

Table 28. Block Addresses and Protection Groups (continued)

Block	Size (KBytes/KWords)	Protection Block Group	(x8)	(x16)
156	64/32	Protection Group	9C0000h–9CFFFFh	4E0000h–4E7FFFh
157	64/32		9D0000h–9DFFFFh	4E8000h–4EFFFFh
158	64/32		9E0000h–9EFFFFh	4F0000h–4F7FFFh
159	64/32		9F0000h–9FFFFFFh	4F8000h–4FFFFFFh
160	64/32	Protection Group	A00000h–A0FFFFh	500000h–507FFFh
161	64/32		A10000h–A1FFFFh	508000h–50FFFFh
162	64/32		A20000h–A2FFFFh	510000h–517FFFh
163	64/32		A30000h–A3FFFFh	518000h–51FFFFh
164	64/32	Protection Group	A40000h–A4FFFFh	520000h–527FFFh
165	64/32		A50000h–A5FFFFh	528000h–52FFFFh
166	64/32		A60000h–A6FFFFh	530000h–537FFFh
167	64/32		A70000h–A7FFFFh	538000h–53FFFFh
168	64/32	Protection Group	A80000h–A8FFFFh	540000h–547FFFh
169	64/32		A90000h–A9FFFFh	548000h–54FFFFh
170	64/32		AA0000h–AAFFFFh	550000h–557FFFh
171	64/32		AB0000h–ABFFFFh	558000h–55FFFFh
172	64/32	Protection Group	AC0000h–ACFFFFh	560000h–567FFFh
173	64/32		AD0000h–ADFFFFh	568000h–56FFFFh
174	64/32		AE0000h–AEFFFFh	570000h–577FFFh
175	64/32		AF0000h–AFFFFFFh	578000h–57FFFFh
176	64/32	Protection Group	B00000h–B0FFFFh	580000h–587FFFh
177	64/32		B10000h–B1FFFFh	588000h–58FFFFh
178	64/32		B20000h–B2FFFFh	590000h–597FFFh
179	64/32		B30000h–B3FFFFh	598000h–59FFFFh
180	64/32	Protection Group	B40000h–B4FFFFh	5A0000h–5A7FFFh
181	64/32		B50000h–B5FFFFh	5A8000h–5AFFFFh
182	64/32		B60000h–B6FFFFh	5B0000h–5B7FFFh
183	64/32		B70000h–B7FFFFh	5B8000h–5BFFFFh
184	64/32	Protection Group	B80000h–B8FFFFh	5C0000h–5C7FFFh
185	64/32		B90000h–B9FFFFh	5C8000h–5CFFFFh
186	64/32		BA0000h–BAFFFFh	5D0000h–5D7FFFh
187	64/32		BB0000h–BBFFFFh	5D8000h–5DFFFFh

Table 28. Block Addresses and Protection Groups (continued)

Block	Size (KBytes/KWords)	Protection Block Group	(x8)	(x16)
188	64/32	Protection Group	BC0000h–BCFFFFh	5E0000h–5E7FFFh
189	64/32		BD0000h–BDFFFFh	5E8000h–5EFFFFh
190	64/32		BE0000h–BEFFFFh	5F0000h–5F7FFFh
191	64/32		BF0000h–BFFFFFFh	5F8000h–5FFFFFFh
192	64/32	Protection Group	C00000h–C0FFFFh	600000h–607FFFh
193	64/32		C10000h–C1FFFFh	608000h–60FFFFh
194	64/32		C20000h–C2FFFFh	610000h–617FFFh
195	64/32		C30000h–C3FFFFh	618000h–61FFFFh
196	64/32	Protection Group	C40000h–C4FFFFh	620000h–627FFFh
197	64/32		C50000h–C5FFFFh	628000h–62FFFFh
198	64/32		C60000h–C6FFFFh	630000h–637FFFh
199	64/32		C70000h–C7FFFFh	638000h–63FFFFh
200	64/32	Protection Group	C80000h–C8FFFFh	640000h–647FFFh
201	64/32		C90000h–C9FFFFh	648000h–64FFFFh
202	64/32		CA0000h–CAFFFFh	650000h–657FFFh
203	64/32		CB0000h–CBFFFFh	658000h–65FFFFh
204	64/32	Protection Group	CC0000h–CCFFFFh	660000h–667FFFh
205	64/32		CD0000h–CDFFFFh	668000h–66FFFFh
206	64/32		CE0000h–CEFFFFh	670000h–677FFFh
207	64/32		CF0000h–CFFFFFFh	678000h–67FFFFh
208	64/32	Protection Group	D00000h–D0FFFFh	680000h–687FFFh
209	64/32		D10000h–D1FFFFh	688000h–68FFFFh
210	64/32		D20000h–D2FFFFh	690000h–697FFFh
211	64/32		D30000h–D3FFFFh	698000h–69FFFFh
212	64/32	Protection Group	D40000h–D4FFFFh	6A0000h–6A7FFFh
213	64/32		D50000h–D5FFFFh	6A8000h–6AFFFFh
214	64/32		D60000h–D6FFFFh	6B0000h–6B7FFFh
215	64/32		D70000h–D7FFFFh	6B8000h–6BFFFFh
216	64/32	Protection Group	D80000h–D8FFFFh	6C0000h–6C7FFFh
217	64/32		D90000h–D9FFFFh	6C8000h–6CFFFFh
218	64/32		DA0000h–DAFFFFh	6D0000h–6D7FFFh
219	64/32		DB0000h–DBFFFFh	6D8000h–6DFFFFh

Table 28. Block Addresses and Protection Groups (continued)

Block	Size (KBytes/KWords)	Protection Block Group	(x8)	(x16)
220	64/32	Protection Group	DC0000h-DCFFFFh	6E0000h-6E7FFFh
221	64/32		DD0000h-DDFFFFh	6E8000h-6EFFFFh
222	64/32		DE0000h-DEFFFFh	6F0000h-6F7FFFh
223	64/32		DF0000h-DFFFFFh	6F8000h-6FFFFFh
224	64/32	Protection Group	E00000h-E0FFFFh	700000h-707FFFh
225	64/32		E10000h-E1FFFFh	708000h-70FFFFh
226	64/32		E20000h-E2FFFFh	710000h-717FFFh
227	64/32		E30000h-E3FFFFh	718000h-71FFFFh
228	64/32	Protection Group	E40000h-E4FFFFh	720000h-727FFFh
229	64/32		E50000h-E5FFFFh	728000h-72FFFFh
230	64/32		E60000h-E6FFFFh	730000h-737FFFh
231	64/32		E70000h-E7FFFFh	738000h-73FFFFh
232	64/32	Protection Group	E80000h-E8FFFFh	740000h-747FFFh
233	64/32		E90000h-E9FFFFh	748000h-74FFFFh
234	64/32		EA0000h-EAFFFFh	750000h-757FFFh
235	64/32		EB0000h-EBFFFFh	758000h-75FFFFh
236	64/32	Protection Group	EC0000h-ECFFFFh	760000h-767FFFh
237	64/32		ED0000h-EDFFFFh	768000h-76FFFFh
238	64/32		EE0000h-EEFFFFh	770000h-777FFFh
239	64/32		EF0000h-EFFFFFh	778000h-77FFFFh
240	64/32	Protection Group	F00000h-F0FFFFh	780000h-787FFFh
241	64/32		F10000h-F1FFFFh	788000h-78FFFFh
242	64/32		F20000h-F2FFFFh	790000h-797FFFh
243	64/32		F30000h-F3FFFFh	798000h-79FFFFh
244	64/32	Protection Group	F40000h-F4FFFFh	7A0000h-7A7FFFh
245	64/32		F50000h-F5FFFFh	7A8000h-7AFFFFh
246	64/32		F60000h-F6FFFFh	7B0000h-7B7FFFh
247	64/32		F70000h-F7FFFFh	7B8000h-7BFFFFh
248	64/32	Protection Group	F80000h-F8FFFFh	7C0000h-7C7FFFh
249	64/32		F90000h-F9FFFFh	7C8000h-7CFFFFh
250	64/32		FA0000h-FAFFFFh	7D0000h-7D7FFFh
251	64/32		FB0000h-FBFFFFh	7D8000h-7DFFFFh
252	64/32	Protection Group	FC0000h-FCFFFFh	7E0000h-7E7FFFh
253	64/32	Protection Group	FD0000h-FDFFFFh	7E8000h-7EFFFFh

Table 28. Block Addresses and Protection Groups (continued)

Block	Size (KBytes/KWords)	Protection Block Group	(x8)	(x16)
254	64/32	Protection Group	FE0000h-FEFFFFh	7F0000h-7F7FFFh
255	64/32	Protection Group	FF0000h-FFFFFFh	7F8000h-7FFFFFFh

Appendix B Common Flash Interface (CFI)

The Common Flash Interface is a JEDEC approved, standardized data structure that can be read from the Flash memory device. It allows a system software to query the device to determine various electrical and timing parameters, density information and functions supported by the memory. The system can interface easily with the device, enabling the software to upgrade itself when necessary.

When the Read CFI Query command is issued, the memory enters Read CFI Query mode and read operations output the CFI data. *Table 29, Table 30, Table 31, Table 32, Table 33 and Table 34* show the addresses (A-1, A0-A10) used to retrieve the data. The CFI data structure also contains a security area where a 64 bit unique security number is written (see *Table 34: Security Code Area*). This area can be accessed only in Read mode by the final user. It is impossible to change the security number after it has been written by Numonyx.

Table 29. Query Structure Overview⁽¹⁾

Address		Sub-section Name	Description
x16	x8		
10h	20h	CFI Query Identification String	Command set ID and algorithm data offset
1Bh	36h	System Interface Information	Device timing & voltage information
27h	4Eh	Device Geometry Definition	Flash device layout
40h	80h	Primary Algorithm-specific Extended Query table	Additional information specific to the Primary Algorithm (optional)
61h	C2h	Security Code Area	64 bit unique device number

1. Query data are always presented on the lowest order data outputs.

Table 30. CFI Query Identification String⁽¹⁾

Address		Data	Description	Value
x16	x8			
10h	20h	0051h	Query Unique ASCII String "QRY"	"Q"
11h	22h	0052h		"R"
12h	24h	0059h		"Y"
13h	26h	0002h	Primary Algorithm Command Set and Control Interface ID code 16 bit ID code defining a specific algorithm	AMD Compatible
14h	28h	0000h		
15h	2Ah	0040h	Address for Primary Algorithm extended Query table (see <i>Table 33</i>)	P = 40h
16h	2Ch	0000h		
17h	2Eh	0000h	Alternate Vendor Command Set and Control Interface ID Code second vendor - specified algorithm supported	NA
18h	30h	0000h		
19h	32h	0000h	Address for Alternate Algorithm extended Query table	NA
1Ah	34h	0000h		

1. Query data are always presented on the lowest order data outputs (DQ7-DQ0) only. DQ8-DQ15 are '0'.

Table 31. CFI Query System Interface Information⁽¹⁾

Address		Data	Description	Value
x16	x8			
1Bh	36h	0027h	V _{CC} Logic Supply Minimum Program/Erase voltage bit 7 to 4BCD value in volts bit 3 to 0BCD value in 100mV	3.0V
1Ch	38h	0036h	V _{CC} Logic Supply Maximum Program/Erase voltage bit 7 to 4BCD value in volts bit 3 to 0BCD value in 100mV	3.6V
1Dh	3Ah	00B5h	V _{PP} [Programming] Supply Minimum Program/Erase voltage bit 7 to 4HEX value in volts bit 3 to 0BCD value in 100mV	11.5V
1Eh	3Ch	00C5h	V _{PP} [Programming] Supply Maximum Program/Erase voltage bit 7 to 4HEX value in volts bit 3 to 0BCD value in 10mV	12.5V
1Fh	3Eh	0004h	Typical timeout per single Byte/Word program = 2 ⁿ μs	16μs
20h	40h	0000h	Typical timeout for minimum size write buffer program = 2 ⁿ μs	NA
21h	42h	0009h	Typical timeout per individual block erase = 2 ⁿ ms	512ms
22h	44h	0000h	Typical timeout for full Chip Erase = 2 ⁿ ms	NA
23h	46h	0005h	Maximum timeout for Byte/Word program = 2 ⁿ times typical	512μs
24h	48h	0000h	Maximum timeout for write buffer program = 2 ⁿ times typical	NA
25h	4Ah	0004h	Maximum timeout per individual block erase = 2 ⁿ times typical	8s
26h	4Ch	0000h	Maximum timeout for Chip Erase = 2 ⁿ times typical	NA

1. The values given in the above table are valid for both packages.

Table 32. Device Geometry Definition

Address		Data	Description	Value
x16	x8			
27h	4Eh	0018h	Device Size = 2 ⁿ in number of Bytes	16 MBytes
28h	50h	0002h	Flash Device Interface Code description	x8, x16 Async.
29h	52h	0000h		
2Ah	54h	0006h	Maximum number of Bytes in Multiple-Byte program or Page= 2 ⁿ	64
2Bh	56h	0000h		
2Ch	58h	0001h	Number of Erase Block Regions. It specifies the number of regions containing contiguous Erase Blocks of the same size.	1
2Dh	5Ah	00FFh	Erase Block Region 1 Information	256
2Eh	5Ch	0000h	Number of Erase Blocks of identical size = 00FFh+1	
2Fh	5Eh	0000h	Erase Block Region 1 Information	64 KBytes
30h	60h	0001h	Block size in Region 1 = 0100h * 256 Byte	

Table 32. Device Geometry Definition (continued)

Address		Data	Description	Value
x16	x8			
31h	62h	0000h	Erase Block Region 2 Information	0
32h	64h	0000h		
33h	66h	0000h		
34h	68h	0000h		
35h	6Ah	0000h	Erase Block Region 3 information	0
36h	6Ch	0000h		
37h	6Eh	0000h		
38h	70h	0000h		
39h	72h	0000h	Erase Block Region 4 information	0
3Ah	74h	0000h		
3Bh	76h	0000h		
3Ch	78h	0000h		

Table 33. Primary Algorithm-Specific Extended Query Table ⁽¹⁾

Address		Data	Description	Value
x16	x8			
40h	80h	0050h	Primary Algorithm extended Query table unique ASCII string "PRI"	"P"
41h	82h	0052h		"R"
42h	84h	0049h		"I"
43h	86h	0031h	Major version number, ASCII	"1"
44h	88h	0033h	Minor version number, ASCII	"3"
45h	8Ah	000Ch	Address Sensitive Unlock (bits 1 to 0) 00 = required, 01 = not required Silicon Revision Number (bits 7 to 2)	Yes
46h	8Ch	0002h	Erase Suspend 00 = not supported, 01 = Read only, 02 = Read and Write	2
47h	8Eh	0001h	Block Protection 00 = not supported, x = number of sectors in per group	1
48h	90h	0001h	Temporary Block Unprotect 00 = not supported, 01 = supported	Yes
49h	92h	0006h	Block Protect /Unprotect 06 = M29W128FH/M29W128FL	6
4Ah	94h	0000h	Simultaneous Operations: Not Supported	NA
4Bh	96h	0000h	Burst Mode, 00 = not supported, 01 = supported	No
4Ch	98h	0002h	Page Mode, 00 = not supported, 02 = 8-Word page	02
4Dh	9Ah	00B5h	V _{PP} Supply Minimum Program/Erase voltage bit 7 to 4 HEX value in volts bit 3 to 0 BCD value in 100mV	11.5V

Table 33. Primary Algorithm-Specific Extended Query Table (continued)⁽¹⁾

Address		Data	Description	Value
x16	x8			
4Eh	9Ch	00C5h	V _{PP} Supply Maximum Program/Erase voltage bit 7 to 4 HEX value in volts bit 3 to 0 BCD value in 100mV	12.5V
4Fh	9Eh	0000h	Top/Bottom Boot Block Flag 00h = Uniform device	Uniform + V _{PP} /W _P Protecting Highest or Lowest Block
50h	A0h	0001h	Program Suspend, 00 = not supported, 01 = supported	Yes

1. The values given in the above table are valid for both packages.

Table 34. Security Code Area

Address		Data	Description
x16	x8		
61h	C3h, C2h	XXXX	64 bit: unique device number
62h	C5h, C4h	XXXX	
63h	C7h, C6h	XXXX	
64h	C9h, C8h	XXXX	

Appendix C Extended Memory Block

The M29W128F has an extra block, the Extended Memory Block, that can be accessed using a dedicated command. This Extended Memory Block is 128 Words in x16 mode and 256 Bytes in x8 mode. It is used as a security block (to provide a permanent security identification number) or to store additional information.

The Extended Memory Block is either Factory Locked or Customer Lockable, its status is indicated by bit DQ7. This bit is permanently set to either '1' or '0' at the factory and cannot be changed. When set to '1', it indicates that the device is factory locked and the Extended Memory Block is protected. When set to '0', it indicates that the device is customer lockable and the Extended Memory Block is unprotected. Bit DQ7 being permanently locked to either '1' or '0' is another security feature which ensures that a customer lockable device cannot be used instead of a factory locked one.

Bit DQ7 is the most significant bit in the Extended Memory Block Verify Indicator and a specific procedure must be followed to read it. See Verify Extended Memory Block Protection Indicator in *Table 4: Block Protection, 8-bit mode* and *Table 7: Block Protection, 16-bit mode*, for details of how to read bit DQ7.

The Extended Memory Block can only be accessed when the device is in Extended Memory Block mode. For details of how the Extended Block mode is entered and exited, refer to the *Section 5.3.1: Enter Extended Memory Block command* and *Section 5.3.2: Exit Extended Block command*, and to *Table 13* and *Table 9*.

C.1 Factory Locked Extended Memory Block

In devices where the Extended Memory Block is factory locked, the Security Identification Number is written to the Extended Memory Block address space (see *Table 35: Extended Memory Block Address and Data*) in the factory. The DQ7 bit is set to '1' and the Extended Memory Block cannot be unprotected.

C.2 Customer Lockable Extended Memory Block

A device where the Extended Memory Block is customer lockable is delivered with the DQ7 bit set to '0' and the Extended Memory Block unprotected. It is up to the customer to program and protect the Extended Memory Block but care must be taken because the protection of the Extended Memory Block is not reversible.

There are two ways of protecting the Extended Memory Block:

- Issue the Enter Extended Block command to place the device in Extended Block mode, then use the In-System Technique with \overline{RP} either at V_{IH} or at V_{ID} (refer to *Appendix D: High Voltage Block Protection*, and to the corresponding flowcharts, *Figure 20* and *Figure 21*, for a detailed explanation of the technique).
- Issue the Enter Extended Block command to place the device in Extended Block mode, then use the Programmer Technique (refer to *Appendix D: High Voltage Block Protection*, and to the corresponding flowcharts, *Figure 18* and *Figure 19*, for a detailed explanation of the technique).

Once the Extended Memory Block is programmed and protected, the Exit Extended Block command must be issued to exit the Extended Memory Block mode and return the device to Read mode.

Table 35. Extended Memory Block Address and Data

Address ⁽¹⁾		Data	
x8	x16	Factory Locked	Customer Lockable
000000h-0000FFh	000000h-00007Fh	Security Identification Number	Determined by Customer

1. See *Table 28: Block Addresses and Protection Groups*.

Appendix D High Voltage Block Protection

The High Voltage Block Protection can be used to prevent any operation from modifying the data stored in the memory. The blocks are protected in groups, refer to *Appendix A: Block addresses and Read/Modify Protection Groups*, and *Table 28* for details of the Protection Groups. Once protected, Program and Erase operations within the protected group fail to change the data.

There are three techniques that can be used to control Block Protection, these are the Programmer technique, the In-System technique and Temporary Unprotection. Temporary Unprotection is controlled by the Reset/Block Temporary Unprotection pin, \overline{RP} ; this is described in the Signal Descriptions section.

To protect the Extended Memory Block issue the Enter Extended Block command and then use either the Programmer or In-System technique. Once protected issue the Exit Extended Block command to return to read mode. The Extended Memory Block protection is irreversible, once protected the protection cannot be undone.

D.1 Programmer technique

The Programmer technique uses high (V_{ID}) voltage levels on some of the bus pins. These cannot be achieved using a standard microprocessor bus, therefore the technique is recommended only for use in Programming Equipment.

To protect a group of blocks follow the flowchart in *Figure 18: Programmer equipment Group Protect flowchart*. To unprotect the whole chip it is necessary to protect all of the groups first, then all groups can be unprotected at the same time. To unprotect the chip follow *Figure 19: Programmer equipment Chip Unprotect flowchart*. *Table 36: Programmer technique Bus operations, 8-bit or 16-bit mode*, gives a summary of each operation.

The timing on these flowcharts is critical. Care should be taken to ensure that, where a pause is specified, it is followed as closely as possible. Do not abort the procedure before reaching the end. Chip Unprotect can take several seconds and a user message should be provided to show that the operation is progressing.

D.2 In-System technique

The In-System technique requires a high voltage level on the Reset/Blocks Temporary Unprotect pin, \overline{RP} ⁽¹⁾. This can be achieved without violating the maximum ratings of the components on the microprocessor bus, therefore this technique is suitable for use after the memory has been fitted to the system.

To protect a group of blocks follow the flowchart in *Figure 20: In-System equipment Group Protect flowchart*. To unprotect the whole chip it is necessary to protect all of the groups first, then all the groups can be unprotected at the same time. To unprotect the chip follow *Figure 21: In-System equipment Chip Unprotect flowchart*.

The timing on these flowcharts is critical. Care should be taken to ensure that, where a pause is specified, it is followed as closely as possible. Do not allow the microprocessor to service interrupts that will upset the timing and do not abort the procedure before reaching the end. Chip Unprotect can take several seconds and a user message should be provided to show that the operation is progressing.

Note: \overline{RP} can be either at V_{IH} or at V_{ID} when using the In-System Technique to protect the Extended Memory Block.

Table 36. Programmer technique Bus operations, 8-bit or 16-bit mode

Operation	\overline{E}	\overline{G}	\overline{W}	Address Inputs A0-A22	Data Inputs/Outputs DQ15A-1, DQ14-DQ0
Block (Group) Protect ⁽¹⁾	V_{IL}	V_{ID}	V_{IL} Pulse	A9 = V_{ID} , A12-A22 Block Address Others = X	X
Chip Unprotect	V_{ID}	V_{ID}	V_{IL} Pulse	A6 = V_{IH} , A9 = V_{ID} , A12 = V_{IH} , A15 = V_{IH} Others = X	X
Block (Group) Protect Verify	V_{IL}	V_{IL}	V_{IH}	A0, A2, A3, A6 = V_{IL} , A1 = V_{IH} A9 = V_{ID} , A12-A22 = Block Address Others = X	Pass = xx01h Retry = xx00h.
Block (Group) Unprotect Verify	V_{IL}	V_{IL}	V_{IH}	A0, A2, A3 = V_{IL} A1, A6 = V_{IH} A9 = V_{ID} , A12-A22 = Block Address Others = X	Pass = xx00h Retry = xx01h.

1. Block Protection Groups are shown in *Appendix D, Table 28*.

Appendix E Flowcharts

Figure 18. Programmer equipment Group Protect flowchart

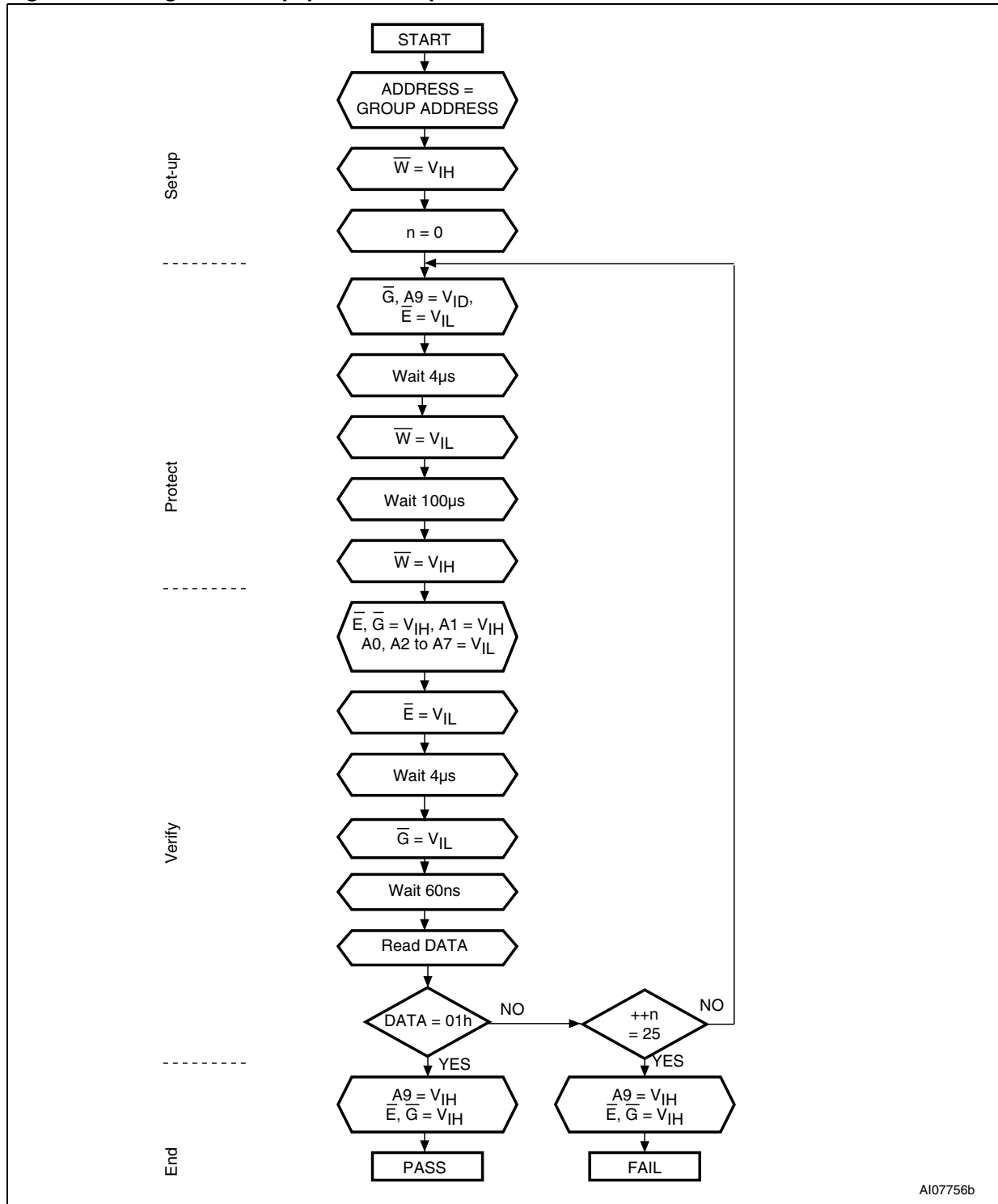

1. Block Protection Groups are shown in Appendix D: High Voltage Block Protection, Table 28.

Figure 19. Programmer equipment Chip Unprotect flowchart

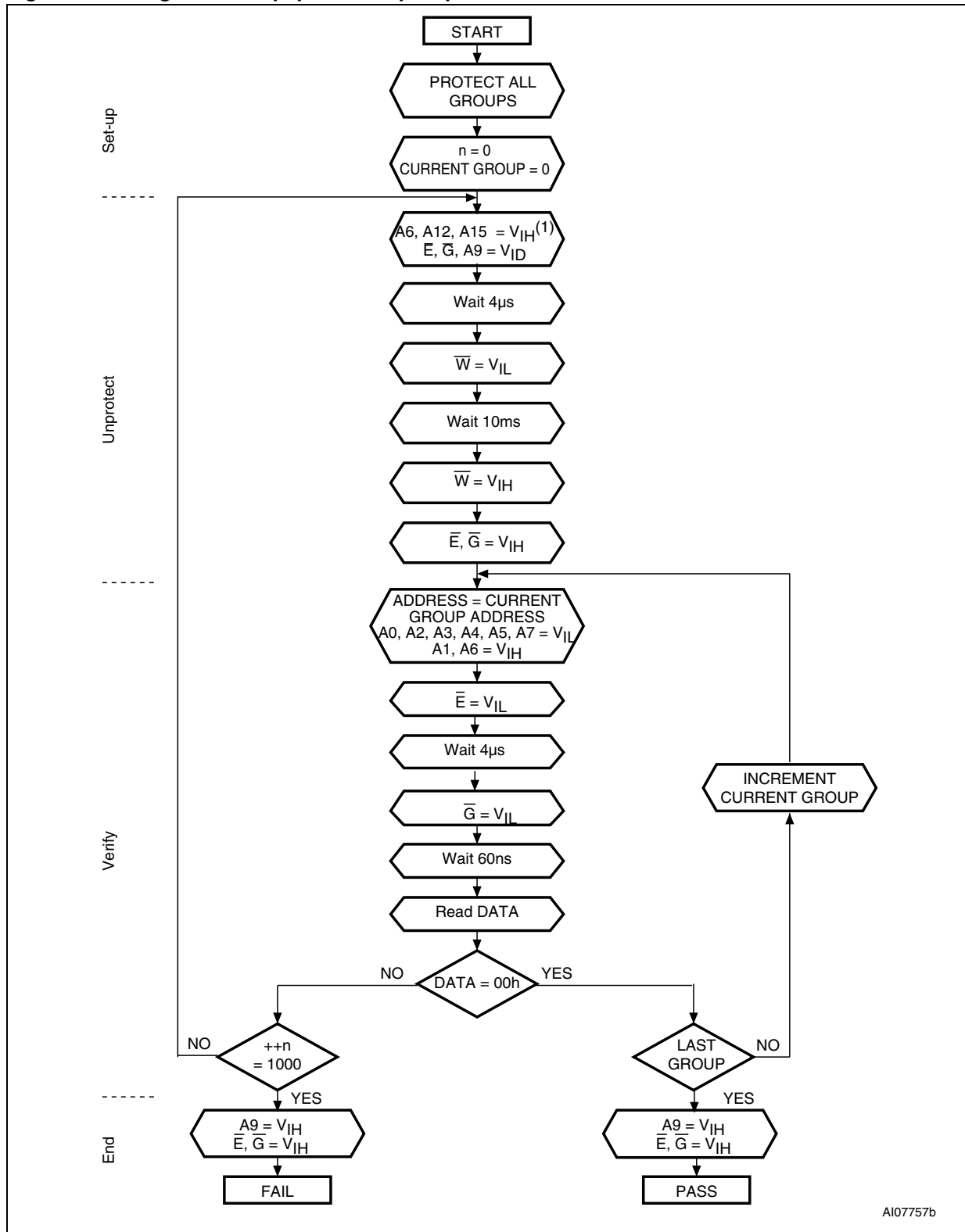

1. Block Protection Groups are shown in Appendix D: High Voltage Block Protection, Table 28.

Figure 20. In-System equipment Group Protect flowchart

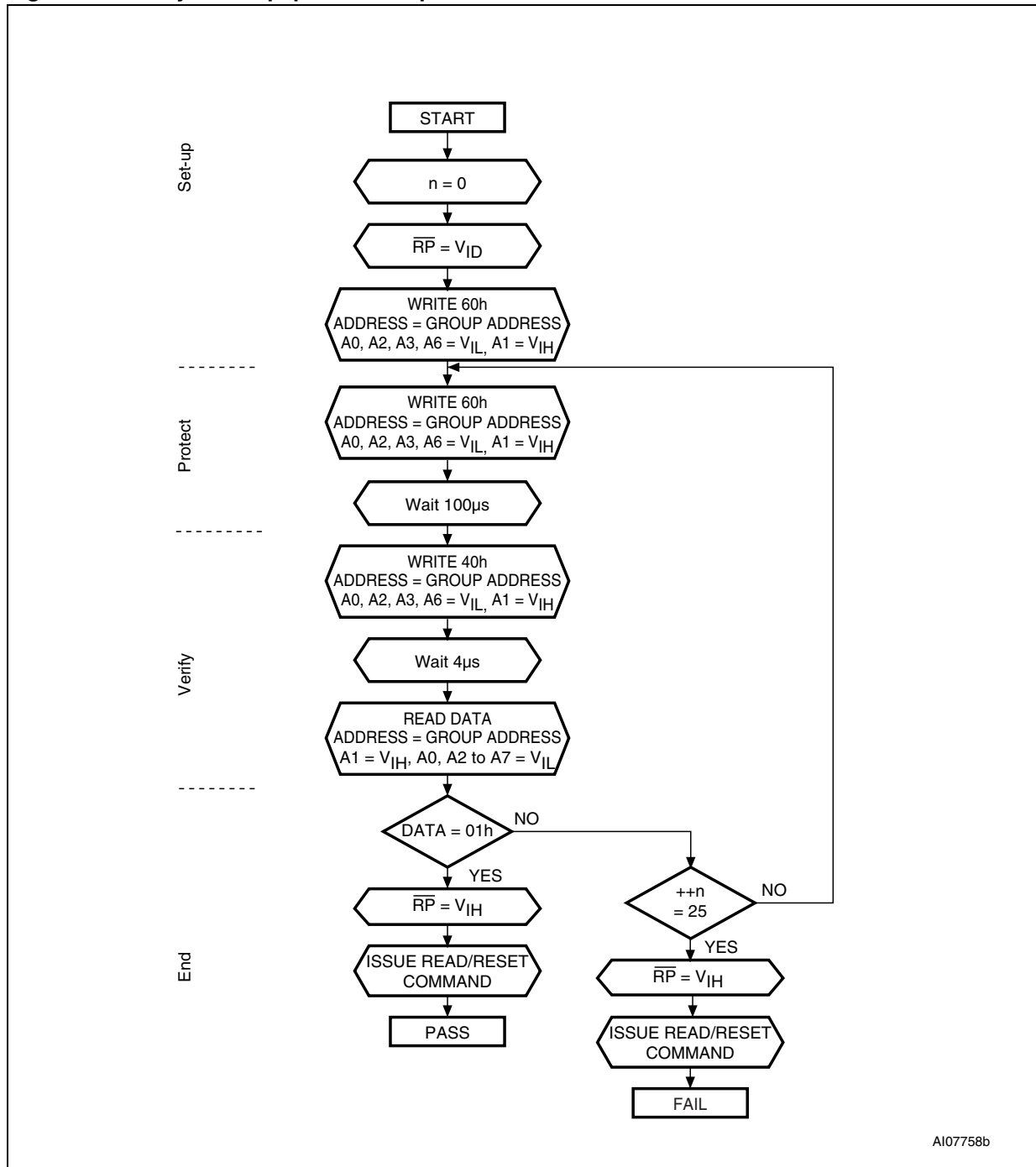

AI07758b

1. Block Protection Groups are shown in *Appendix D: High Voltage Block Protection, Table 28*.
2. \overline{RP} can be either at V_{IH} or at V_{ID} when using the In-System Technique to protect the Extended Memory Block.

Figure 21. In-System equipment Chip Unprotect flowchart

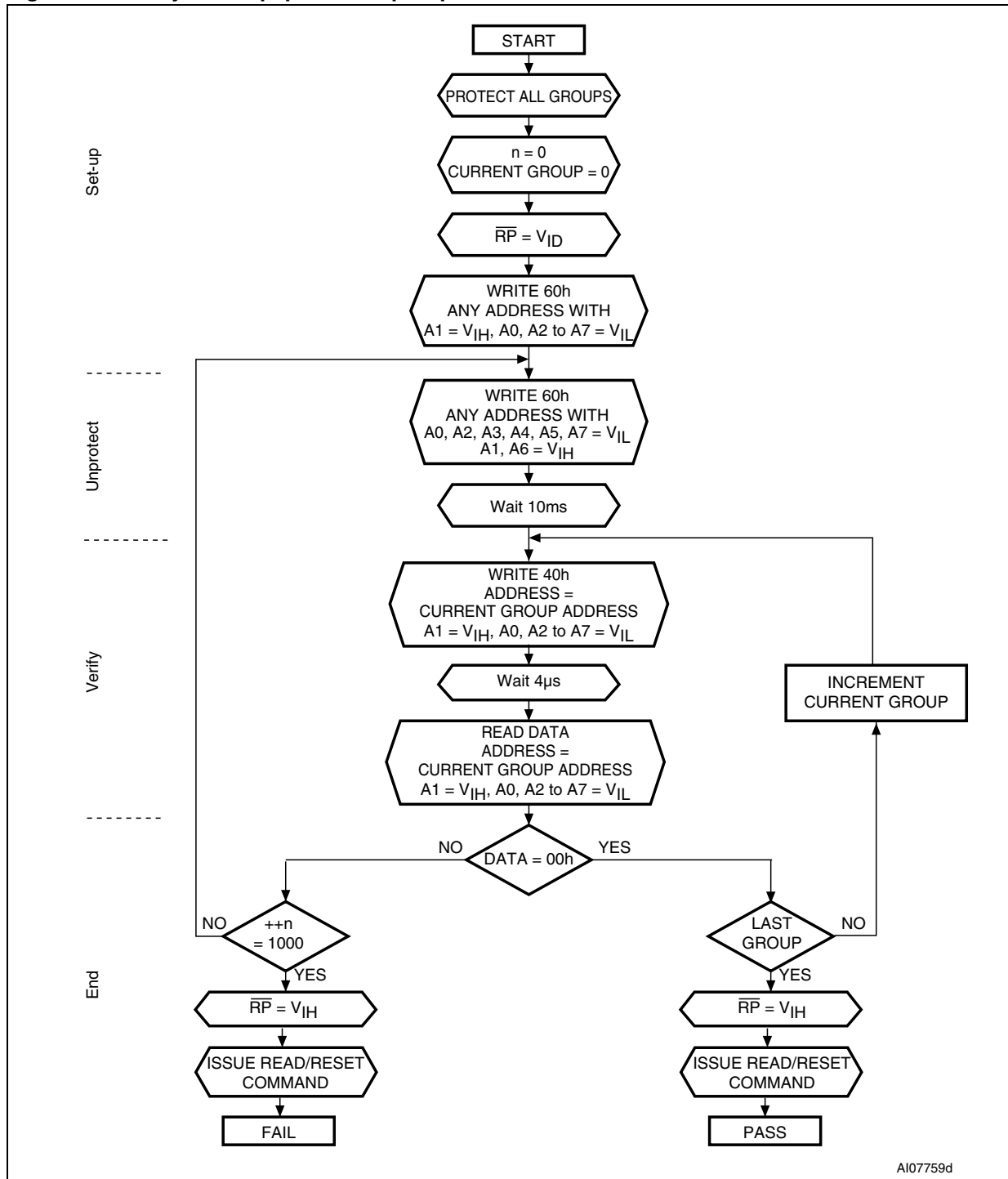

AI07759d

1. Block Protection Groups are shown in Appendix D: High Voltage Block Protection, Table 28.

Figure 22. Write to Buffer and Program flowchart and Pseudo Code

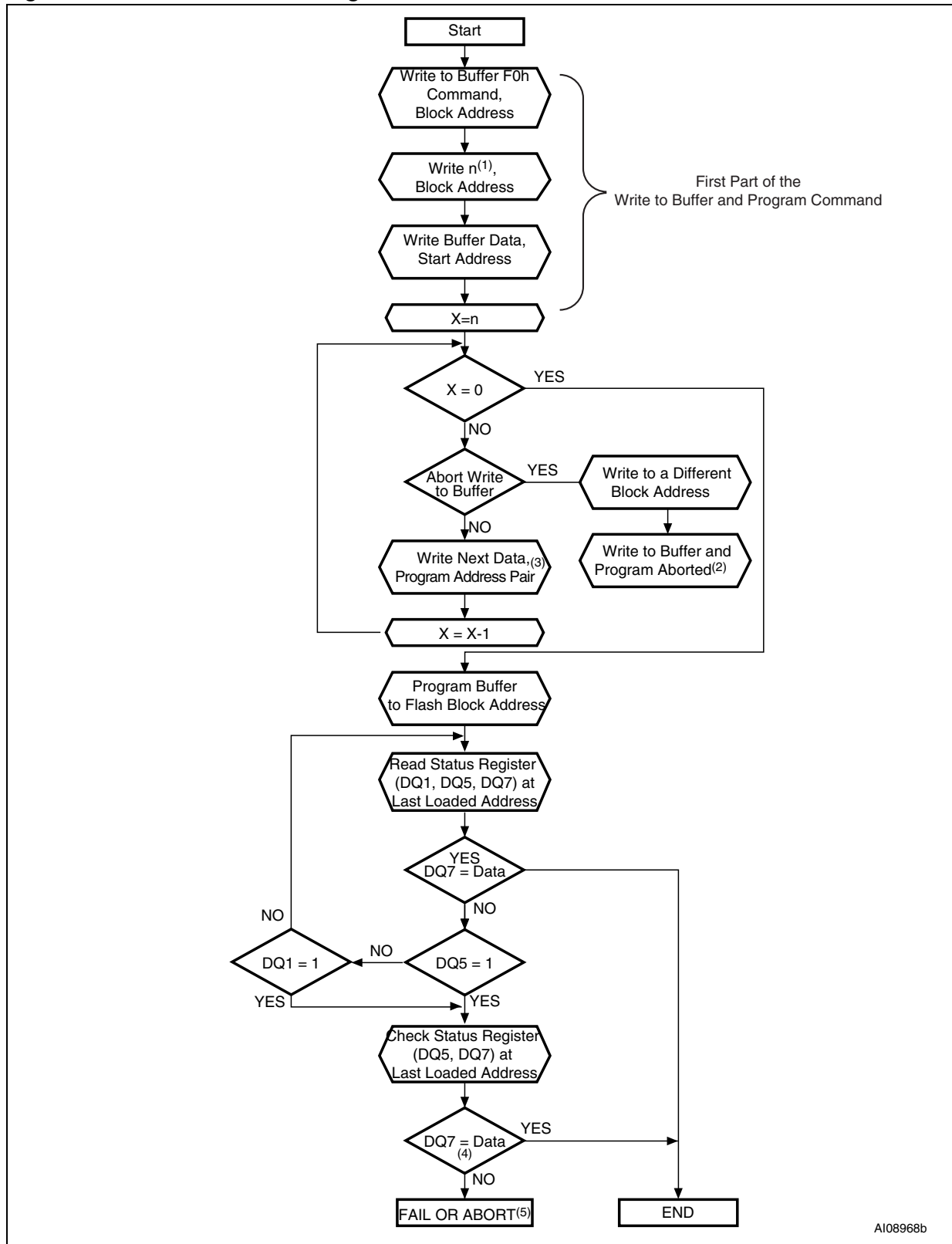

1. n+1 is the number of addresses to be programmed.

2. A Write to Buffer and Program Abort and Reset must be issued to return the device in Read mode.
3. When the block address is specified, any address in the selected block address space is acceptable. However when loading Write Buffer address with data, all addresses must fall within the selected Write Buffer page.
4. DQ7 must be checked since DQ5 and DQ7 may change simultaneously.
5. If this flowchart location is reached because $DQ5=1$, then the Write to Buffer and Program command failed. If this flowchart location is reached because $DQ1=1$, then the Write to Buffer and Program command aborted. In both cases, the appropriate reset command must be issued to return the device in Read mode: a Reset command if the operation failed, a Write to Buffer and Program Abort and Reset command if the operation aborted.
6. See *Table 9* and *Table 10*, for details on Write to Buffer and Program command sequence.

Revision history

Table 37. Document revision history

Date	Version	Changes
29-Sep-2005	0.1	First Issue.
02-Dec-2005	1	Document status changed to "Full Datasheet". Title updated. Program Suspend Latency time updated in <i>Table 15: Program, Erase Times and Program, Erase Endurance cycles</i> .
07-Mar-2006	2	DQ7 changed to $\overline{DQ7}$ for Program, Program During Erase Suspend and Program Error in <i>Table 16: Status register bits</i> .
13-Mar-2006	3	<i>Section 5.2.1: Write to Buffer and Program command</i> , and <i>Section 5.2.2: Write to Buffer and Program Confirm command</i> updated to cover 8-bit mode. <i>Note 2</i> , <i>Note 3</i> , and <i>Note 4</i> updated in <i>Table 11: Fast Program commands, 8-bit mode</i> .
06-Apr-2006	4	Verify Extended Memory Block Protection bit command removed.
25-Oct-2006	5	<i>Table 16: Status register bits</i> updated.
06-Nov-2006	6	DQ7 was replaced by $\overline{DQ7}$ for 'Write to Buffer and Program Abort' in <i>Table 16: Status register bits</i> .
10-Dec-2007	7	Applied Numonyx branding.

Please Read Carefully:

INFORMATION IN THIS DOCUMENT IS PROVIDED IN CONNECTION WITH NUMONYX™ PRODUCTS. NO LICENSE, EXPRESS OR IMPLIED, BY ESTOPPEL OR OTHERWISE, TO ANY INTELLECTUAL PROPERTY RIGHTS IS GRANTED BY THIS DOCUMENT. EXCEPT AS PROVIDED IN NUMONYX'S TERMS AND CONDITIONS OF SALE FOR SUCH PRODUCTS, NUMONYX ASSUMES NO LIABILITY WHATSOEVER, AND NUMONYX DISCLAIMS ANY EXPRESS OR IMPLIED WARRANTY, RELATING TO SALE AND/OR USE OF NUMONYX PRODUCTS INCLUDING LIABILITY OR WARRANTIES RELATING TO FITNESS FOR A PARTICULAR PURPOSE, MERCHANTABILITY, OR INFRINGEMENT OF ANY PATENT, COPYRIGHT OR OTHER INTELLECTUAL PROPERTY RIGHT.

Numonyx products are not intended for use in medical, life saving, life sustaining, critical control or safety systems, or in nuclear facility applications.

Numonyx may make changes to specifications and product descriptions at any time, without notice.

Numonyx, B.V. may have patents or pending patent applications, trademarks, copyrights, or other intellectual property rights that relate to the presented subject matter. The furnishing of documents and other materials and information does not provide any license, express or implied, by estoppel or otherwise, to any such patents, trademarks, copyrights, or other intellectual property rights.

Designers must not rely on the absence or characteristics of any features or instructions marked "reserved" or "undefined." Numonyx reserves these for future definition and shall have no responsibility whatsoever for conflicts or incompatibilities arising from future changes to them.

Contact your local Numonyx sales office or your distributor to obtain the latest specifications and before placing your product order.

Copies of documents which have an order number and are referenced in this document, or other Numonyx literature may be obtained by visiting Numonyx's website at <http://www.numonyx.com>.

Numonyx StrataFlash is a trademark or registered trademark of Numonyx or its subsidiaries in the United States and other countries.

*Other names and brands may be claimed as the property of others.

Copyright © 11/5/7, Numonyx, B.V., All Rights Reserved.