

PLEASE CHECK WWW.MOLEX.COM FOR LATEST PART INFORMATION

Part Number: **0524841010**
Status: **Active**
Description: 2.0 W/B CONN. IDT REC. HSG ASSY

Documents:

3D Model	Product Specification PS-52484-011 (PDF)
Drawing (PDF)	Product Specification PS-52484-012 (PDF)
Product Specification PS-51090-003 (PDF)	Product Specification PS-52484-021 (PDF)
Product Specification PS-51090-007 (PDF)	Product Specification PS-52484-022 (PDF)
Product Specification PS-52478-001 (PDF)	Product Specification PS-53358-001 (PDF)
Product Specification PS-52478-002 (PDF)	Product Specification PS-55460-001 (PDF)
Product Specification PS-52484-004 (PDF)	Product Specification PS-55533-003 (PDF)
Product Specification PS-52484-009 (PDF)	RoHS Certificate of Compliance (PDF)

Agency Certification

CSA	LR19980
UL	E29179

General

Product Family	IDT and Solder Connectors
Series	<u>52484</u>
Crimp Quality Equipment	Yes
Product Name	Mi II™

Physical

Circuits (Loaded)	10
Color - Resin	Natural
Durability (mating cycles max)	30
Flammability	94V-0
Gender	Female
Glow-Wire Compliant	No
Lock to Mating Part	None
Material - Metal	Phosphor Bronze
Material - Plating Mating	Tin
Material - Plating Termination	Tin
Material - Resin	Nylon
Number of Rows	1
Packaging Type	Bag
Panel Mount	No
Pitch - Mating Interface (in)	0.079 In
Pitch - Mating Interface (mm)	2.00 mm
Plating min: Mating (µin)	36
Plating min: Mating (µm)	0.90
Plating min: Termination (µin)	36
Plating min: Termination (µm)	0.90
Temperature Range - Operating	-40°C to +105°C
Wire Insulation Diameter	0.85-1.05mm (.033-.041")
Wire Size AWG	26, 28

Electrical

Current - Maximum per Contact	1.5A
Voltage - Maximum	125V

Material Info

Reference - Drawing Numbers

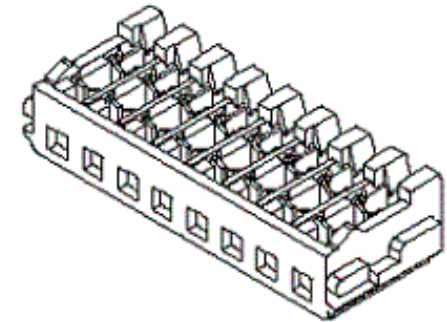

image - Reference only

Series

EU RoHS

ELV and RoHS Compliant

REACH SVHC

Not Reviewed

Halogen-Free

Status

Not Reviewed

Need more information on product environmental compliance?

Email productcompliance@molex.com
 For a multiple part number RoHS Certificate of Compliance, [click here](#)

Please visit the [Contact Us](#) section for any non-product compliance questions.

China RoHS



Search Parts in this Series

[52484Series](#)

Mates With

[51206](#) , [53313](#) , [55460](#) , [53358](#) , [53324](#) , [53325](#)

Application Tooling | FAQ

Tooling specifications and manuals are found by selecting the products below. Crimp Height Specifications are then contained in the Application Tooling Specification document.

Japan

Description	Product #
Hand Crimper	0573255000
Die Set For	0572257000
57222-7000	
IDT Bench-Top Terminator (Small Type) for Mi II™	0572257100
Fully-Automated IDT Machine (XELOM-PLUS)	0578008000

Product Specification

PS-51090-003, PS-51090-007, PS-52478-001,
PS-52478-002, PS-52484-004, PS-52484-009,
PS-52484-011, PS-52484-012, PS-52484-021,
PS-52484-022, PS-53358-001, PS-55460-001,
PS-55533-003, RPS-51090-002, RPS-51090-005,
RPS-51090-019, RPS-51090-021, RPS-52484-002,
RPS-52484-005, RPS-52484-015, RPS-52484-016,
RPS-52484-017, RPS-52484-019, RPS-52484-020,
RPS-52484-022, RPS-52484-024, RPS-52484-025,
RPS-52484-026, RPS-52969-004, RPS-52969-005,
RPS-52969-006, RPS-53358-001, RPS-54111-005,
RPS-55460-015
SD-52484-008

Sales Drawing

Fully-Automated IDT 0578008400
Machine (XELOM-
PLUS)
Fully-Automated IDT 0578258000
Machine (XELOM-
SIMPLE)
IDT Bench-Top 0578657000
Terminator for Mi II™

This document was generated on 04/16/2010

PLEASE CHECK WWW.MOLEX.COM FOR LATEST PART INFORMATION

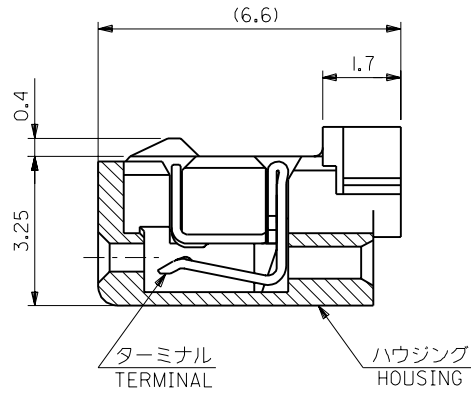
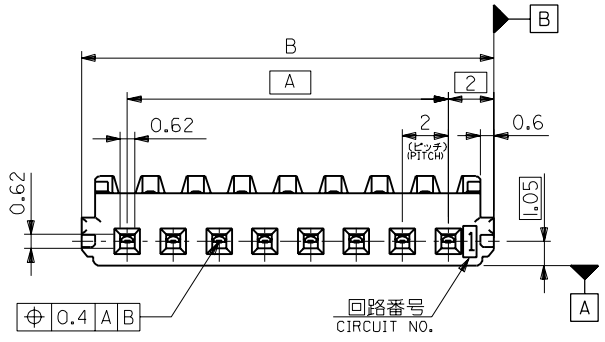
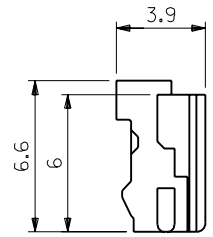
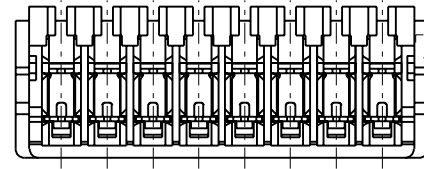
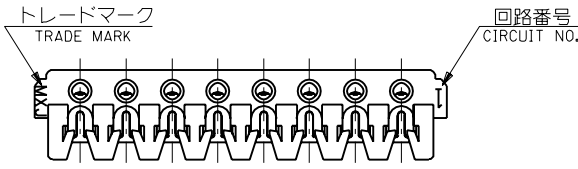

ターミナル装着状態図
FIGURE OF TERMINAL WHEN ASSEMBLED
(SCALE : 10-1)

注記 NOTES

1. 嵌合相手: 53324-***0, 53325-***0, 53358-***0, 53401-***0
MATES WITH
2. 材質 MATERIAL
ハウジング: ガラス入り66ナイロン, UL94V-0, 色: 表参照
HOUSING: GLASS FILLED 66 NYLON, UL94V-0, COLOR: SEE CHART
ターミナル: りん青銅, 錫メッキ (t=0.2)
TERMINAL: PHOSPHOR BRONZE, PRE-TINNED (t=0.2)
3. 適合クリップ: 51094-***05
APPLICABLE CLIP



製品番号 MATERIAL NO.
52484-***
極数 CIRCUIT SIZE

ナチュラル(白) NATURAL(WHITE)	0
赤 RED	2
黄 YELLOW	3
青 BLUE	4

32	28	52484-151*	15	52484-***1*
30	26	-141*	14	
28	24	-131*	13	
26	22	-121*	12	
24	20	-111*	11	
22	18	-101*	10	
20	16	-091*	9	
18	14	-081*	8	
16	12	-071*	7	
14	10	-061*	6	
12	8	-051*	5	
10	6	-041*	4	
8	4	-031*	3	
6	2	52484-021*	2	
B	A	製品番号 MATERIAL NO.	極数 CIRCUIT	MODEL NO.

EC NO. DRWN: CHK: APPR:	EC NO. DRWN: CHK: APPR:	EC NO. DRWN: CHK: APPR:	EC NO. DRWN: CHK: APPR:	EC NO. DRWN: CHK: APPR:	RELEASED EC No. JD2000-0703 DRWN: K.KOBAYASHI 00/05/07 CHK: J.MIYAZAWA 00/05/07 APPR: H.IKESUGI 00/05/07	DESCRIPTION	MATERIAL 材料	GENERAL TOLERANCES: (UNLESS SPECIFIED) 一般公差	SCALE 5-1	DESIGN UNITS <input checked="" type="checkbox"/> mm <input type="checkbox"/> INCH	THIRD ANGLE PROJECTION	DIMENSIONS: <input type="checkbox"/> mm <input type="checkbox"/> INCH <input checked="" type="checkbox"/> mm ONLY	SHT REV
							注参照 SEE NOTES	10 UNDER 未満	+0.2	DRAWN BY & DATE K Kobayashi 00/05/07	TITLE: 2.0 W/B CONN. IDT REC. HS'G ASS'Y		
							注参照 SEE NOTES	10 OVER 以上	+0.25	CHECKED BY & DATE Masumi 00/05/07			
							WIRE RANGE 適用線径範囲	30 OVER 以上	+0.3	APPROVED BY & DATE 00/05/07		MOLEX INCORPORATED	
							AWG #26-#28	ANGLE 角度	+3°	CAD FILE NAME 52484008.S01	MATERIAL NO. SEE CHART	DRAWING NO. SD-52484-008	SHEET NO. 1 OF 1
							INS. RANGE 被覆外径	∅1.05 MAX.		THIS DRAWING CONTAINS INFORMATION THAT IS PROPRIETARY TO MOLEX INCORPORATED AND SHOULD NOT BE USED WITHOUT WRITTEN PERMISSION.			SIZE B