

FEATURES/BENEFITS

- Zero switching AC output
- DC control input
- Fault detection: line or load open; short-circuit output
- Solid-state N.C. status output without power supply
- Control and status LED indicators
- Terminal block for control and status output connections



Part Number	Description
SS24D50	50A, 70–280 Vac with diagnostic
SS24D75	75A, 70–280 Vac with diagnostic
SS48D50	50A, 150–510 Vac with diagnostic
SS48D75	75A, 150–510 Vac with diagnostic

Part Number Explanation

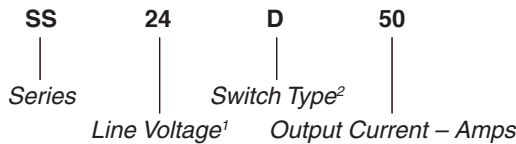

ELECTRICAL SPECIFICATIONS

(+25°C ambient temperature unless otherwise specified)

INPUT (CONTROL) SPECIFICATIONS

	Min	Max	Units
Control Range			
SS24	7	32	V
SS48	8	32	V
Input Current Range			
SS24	4	30	mA
SS48	4	28	mA
Must Turn-Off Voltage			
SS24	3		V
SS48	4		V

Input Resistance (Typical)

All relays	1000	Ohms
------------	------	------

Reverse Voltage Protection

All relays	30	V
------------	----	---

MECHANICAL SPECIFICATION

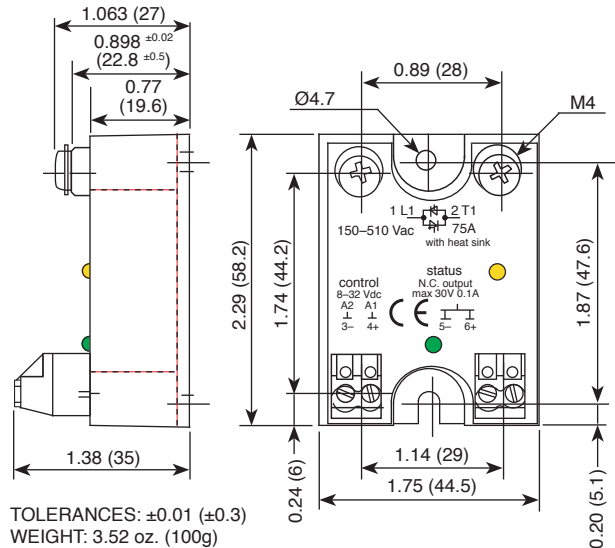
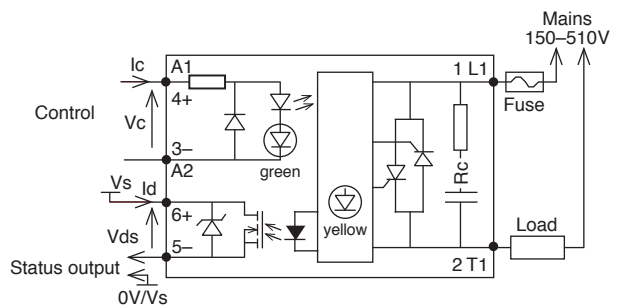

Figure 1

BLOCK DIAGRAM



Without faults, the status output is normally closed (NC)

Figure 2

STATUS OUTPUT SPECIFICATIONS

	Min	Max	Units
Supply Voltage	1	32	V
Output Current	0	0.1	A
On Resistance		2	Ohms
Maximum Cable Length		40	m

ELECTRICAL SPECIFICATIONS

(+25°C ambient temperature unless otherwise specified)

OUTPUT (LOAD) SPECIFICATIONS

	Min	Max	Units
Operating Range			
SS24	70	280	Vrms
SS48	150	510	Vrms

Peak Voltage

	Min	Max	Units
SS24		600	Vpeak
SS48		1200	Vpeak

Load Current Range

	Min	Max	Units
50A output current	.1	50	Arms
75A output current	.1	75	Arms

Maximum Surge Current Rating (Resistive)

	Min	Max	Units
50A output current		550	A
75A output current		1000	A

On-State Voltage Drop

	Min	Max	Units
50A output current		1.45	V
75A output current		1.35	V

Zero-Cross Window (Typical)

	Min	Max	Units
All relays		±14	V

Off-State Leakage Current (60 Hz)

	Min	Max	Units
All relays		5	mA

Turn-On Time (60 Hz)

	Min	Max	Units
All relays		8.3	ms

Turn-Off Time (60 Hz)

	Min	Max	Units
All relays		8.3	ms

Off-State dv/dt

	Min	Max	Units
All relays		500	V/μs

Maximum di/dt (Non-Repetitive)

	Min	Max	Units
All relays		50	A/μs

OUTPUT (LOAD) SPECIFICATIONS (Continued)

	Min	Max	Units
I ² t for Match Fusing (<8.3 ms)			
50A output current		1500	A ² S
75A output current		5000	A ² S
Operating Frequency Range			
All relays	47	63	Hz

CONTROL CHARACTERISTIC

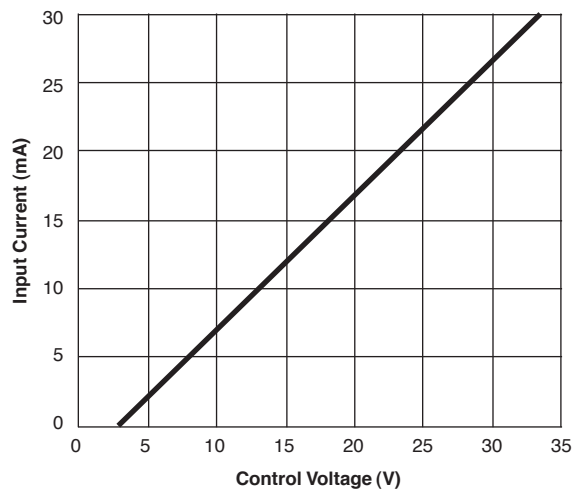

Figure 3

SURGE CURRENT

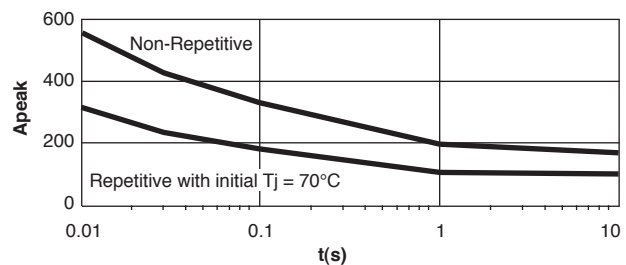

Figure 4a — 50A relays

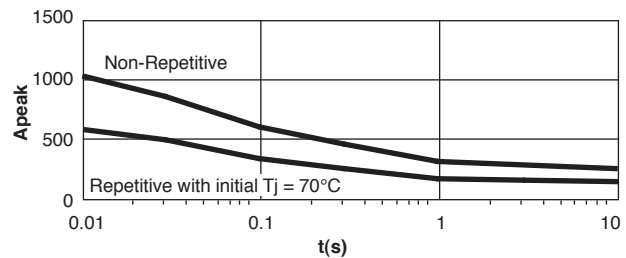

Figure 4b — 75A relays

GENERAL SPECIFICATIONS

(+25°C ambient temperature unless otherwise specified)

ENVIRONMENTAL SPECIFICATIONS

	Min	Max	Units
Operating Temperature	-40	+90	°C
Storage Temperature	-40	+100	°C
Junction Case Thermal Resistance		0.5	°C/W
Input-Output Isolation	3750		Vrms
Input, Output, Case Isolation	3300		Vrms
Status, Output, Input Isolation	2500		Vrms
Rated Impulse Voltage	4000		V

THERMAL CHARACTERISTICS

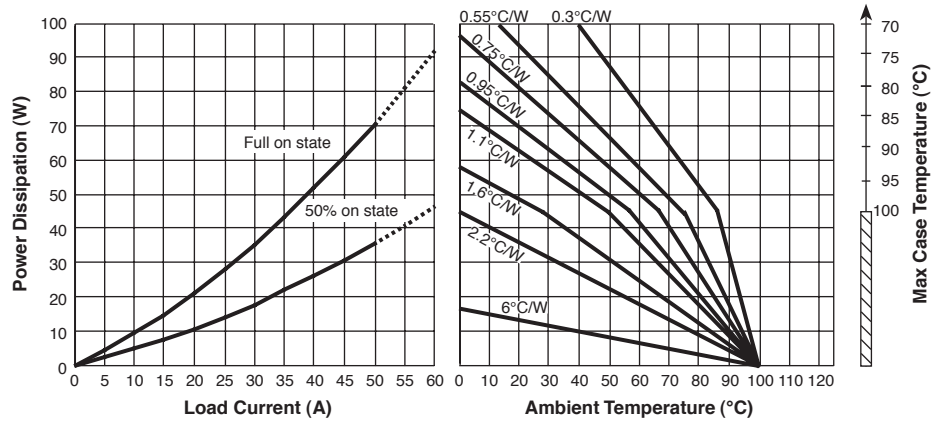

Figure 5a — 50A output current

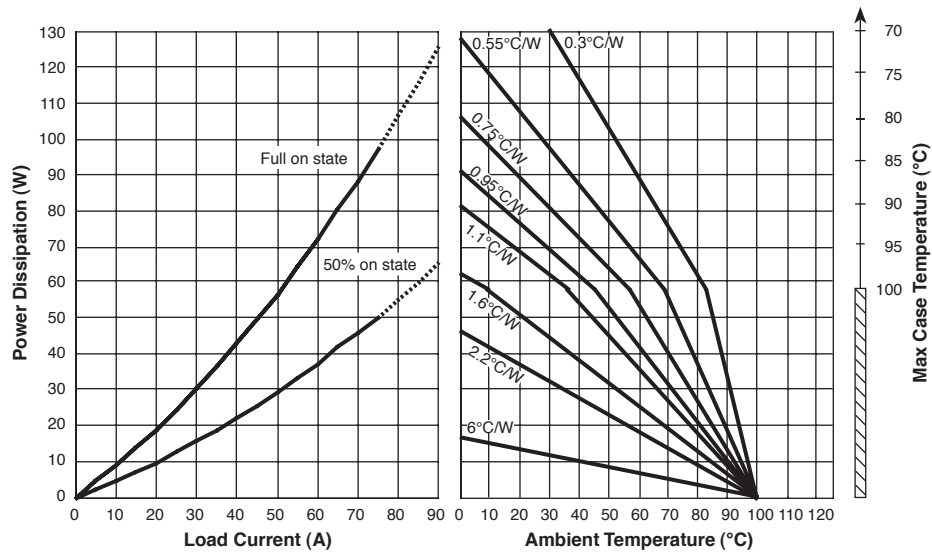

Figure 4b — 75A output current

DIAGNOSTIC DESCRIPTION

Control	Control LED	Mains	Load	SSR	Output LED	Output Status
0	○	No	X	X	○	Open
1	●	No	X	X	○	Open
0	○	Yes	OK	OK	●	Closed
1	●	Yes	OK	OK	●	Closed
0	○	Yes	Open	OK	○	Open
0	○	Yes	OK	Short circuit	○	Open
1	●	Yes	Open	OK	○	Open
1	●	Yes	OK	Short circuit	○	Open

Figure 6

- The yellow LED luminosity depends on:
 - Load voltage.
 - Control: ON or OFF.
 - Load type.
- The status outputs can be connected in series.
- NPN or PNP output is possible with status.
- Mains voltage lower than specifications (150 Vac). The SSR works correctly, but an alarm status can be given without control.

DIAGNOSTIC OVERVIEW

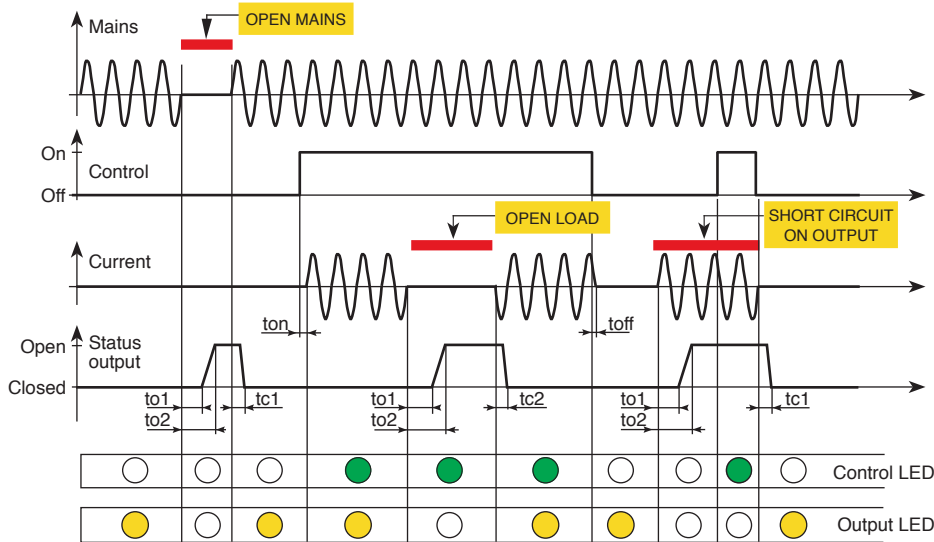

Figure 7

- Output status is normally closed without failure on the relay and the load. The output LED is normally ON.
- In case of failure on the load (open) or on the SSR (short-circuit condition):
 - the status is open
 - the output LED is switched OFF

Important: If you use a long wiring cable between the SSR and the load (>25 meters), the diagnostic system might not be able to detect an open load.

TIMING SPECIFICATIONS

(+25°C ambient temperature unless otherwise specified)

	Min	Max	Units
t01 – Open Delay (Typical)		70	ms
t02 – Open Time (Typical)		120	ms
tc1 – Close Time		20	ms
tc2 – Close Time		20	ms

NOTES

1. For additional/custom options, contact factory.