

CY8C9520, CY8C9540, and CY8C9560



20-, 40-, and 60-Bit I/O Expander with EEPROM

Features

- I2C™ interface logic electrically compatible with SMBus.
- Up to 20 (CY8C9520), 40 (CY8C9540) or 60 (CY8C9560) I/O data pins independently configurable as inputs, outputs, bi-directional input/outputs or PWM outputs.
- 4/8/16 PWM sources with 8-bit resolution.
- Extendable Soft Addressing™ algorithm allowing flexible I2C-address configuration.
- Internal 3-/11-/27-Kbyte EEPROM.
- Storage of user defaults and I/O port settings in the internal EEPROM.
- Optional EEPROM Write Disable (WD) input.
- Interrupt output indicates input pin level changes and pulse width modulator (PWM) state changes.
- Internal power-on reset (POR).

Overview

The CY8C95xx is a multi-port I/O expander with on-board user-available EEPROM and several PWM outputs. All devices in this family operate identically but differ in I/O pins, number of PWMs, and internal EEPROM size.

The CY8C95xx operates as two I2C slave devices. The first device is a multi-port I/O expander (single I2C address to access all ports via registers). The second device is a serial EEPROM. Dedicated configuration registers can be used to disable the EEPROM. The EEPROM utilizes 2-byte addressing to support the 28-Kbyte EEPROM address space. The selected device is defined by the most significant bits of the I2C address or by specific register addressing.

The I/O expander's data pins can be independently assigned as inputs, outputs, quasi-bidirectional input/outputs or PWM outputs. The individual data pins can be configured as open drain/collector, strong drive (10 mA source, 25 mA sink), resistively pulled-up/-down, or high-impedance. The factory default configuration is pulled-up internally.

The system master writes to the I/O configuration registers via the I2C bus. Configuration and output register settings can be stored as user defaults in a dedicated section of the EEPROM. If user defaults have been stored in EEPROM, they are restored to the ports at power-up. While this device can share the bus with SMBus devices, it can only communicate with I2C-masters.

There is one dedicated pin that is configured as an interrupt output (INT) and can be connected to the interrupt logic of the system master. This signal can inform the system master that there is incoming data on its ports or that the PWM output state was changed.

The EEPROM is byte-readable and supports byte-by-byte writing. A pin can be configured as an EEPROM Write Disable (WD) input that blocks write operations when set high. The configuration registers can also disable EEPROM operations.

The CY8C95xx has one fixed address pin (A0) and up to six additional pins (A1-A6) which allow up to 128 devices to share a common two-wire I2C data bus. The Extendable Soft Addressing algorithm provides the option to choose the number of pins needed to assign the desired address. Pins not used for address bits are available as GPIO pins.

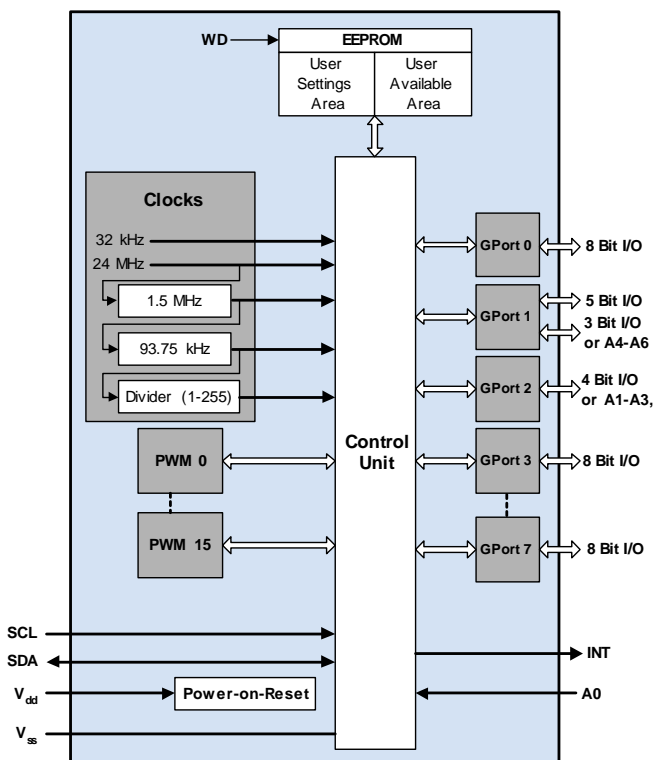

Figure 1-1. Top Level Block Diagram

There are 4 (CY8C9520), 8 (CY8C9540) or 16 (CY8C9560) independently configurable 8-bit PWMs. These PWMs are denoted as PWM0-PWM15. Each PWM can be clocked by one of six available clock sources.

Architecture

The figure titled “Top Level Block Diagram” on page 1 illustrates the device block diagram. The main blocks include the control unit, PWMs, EEPROM and I/O ports. The control unit executes commands received from the I2C bus and transfers data between other bus devices and the master device.

The on-chip EEPROM can be separated conventionally into two regions. The first region is designed to store data and is available for byte-wide read/writes via the I2C bus. It is possible to prevent write operations by setting the WD pin to high. All EEPROM operations can be blocked by configuration register settings. The second region allows the user to store the port and PWM default settings using special commands. These defaults will be automatically reloaded and processed after device power-on.

The number of I/O lines and PWM sources is presented in the following table.

Table 1-1. GPIO Availability

Port	CY8C9520	CY8C9540	CY8C9560
GPort 0	8 bit	8 bit	8 bit
GPort 1	5-8 bit*	5-8* bit	5-8 bit*
GPort 2	0-4 bit*	0-4* bit	0-4 bit*
GPort 3	-	8 bit	8 bit
GPort 4	-	8 bit	8 bit
GPort 5	-	4 bit	8 bit
GPort 6	-	-	8 bit
GPort 7	-	-	8 bit
PWMs	4	8	16

* This port contains configuration-dependant GPIO lines or A1-A6 and WD lines.

There are four pins on GPort 2 and three on GPort 1 that can be used as general purpose I/O or EEPROM Write Disable (WD) and I2C-address input (A1-A6), depending on configuration settings.

The figure titled “Logical Structure of the I/O Port” shows the single port logical structure. The Port Drive Mode register gives the option to select one of seven available modes for each pin separately: pulled-up/-down, open drain high/low, strong drive fast/slow, or high-impedance. By default these configuration registers store values setting I/O pins to pulled-up. The Invert register allows for inversion of the logic of the Input registers separately for each pin. The Select PWM register allows pins to be assigned as PWM outputs. All of these configuration registers are read/writable using corresponding commands in the multi-port device.

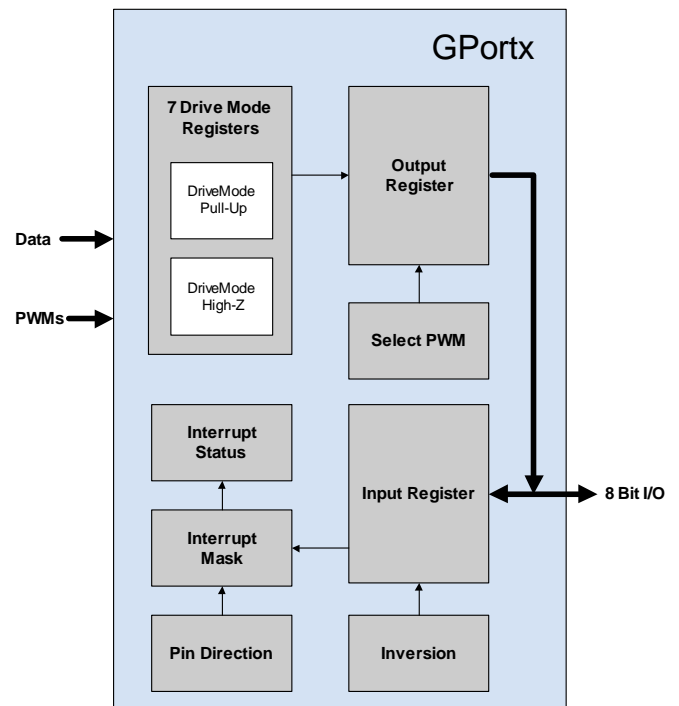

Figure 1-2. Logical Structure of the I/O Port

The Port Input and Output registers are separated. When the Output register is written, the data is sent to the external pins. When the Input register is read, the external pin logic levels are captured and transferred. As a result, the read data can be different from written Output register data. This allows for implementation of a quasi-bidirectional input-output mode, when the corresponding binary digit is configured as pulled-up/down output.

Each GPort has an Interrupt Mask register and an Interrupt Status register. Each high bit in the Interrupt Status register signals that there has been a change in the corresponding input line since the last read of that Interrupt Status register. The Interrupt Status register is cleared after each read. The Interrupt Mask register enables/disables activation of the INT line when input levels are changed. Each high in the Interrupt Mask register masks (disables) an interrupt generated from the corresponding input line.

Applications

Each GPIO pin can be used to monitor and control various board-level devices, including LEDs and system intrusion detection devices.

The on-board EEPROM can be used to store information such as error codes or board manufacturing data for read-back by application software for diagnostic purposes.

Device Access Addressing

Following a start condition, the I2C master device sends a byte to address an I2C slave. This address selects the device to be accessed in the CY8C95xx. By default there are two possible address formats in binary representation: 010000A0X and 101000A0X. The first is used to access the multi-port device and the second to access the EEPROM. If additional address lines (A1-A6) are used then the Device Addressing Table 1-2 defines the device addresses. This addressing method uses a technique called Extendable Soft Addressing™, described later in this document.

Table 1-2. Device Addressing

Multi-Port Device								EEPROM Device							
01		0	0	0	0	A ₀	R/ \overline{W}	1	0	1	0	0	0	A ₀	R/ \overline{W}
0	1	0	0	0	A ₁	A ₀	R/ \overline{W}	1	0	1	0	0	A ₁	A ₀	R/ \overline{W}
0	1	0	0	A ₂	A ₁	A ₀	R/ \overline{W}	1	0	1	0	A ₂	A ₁	A ₀	R/ \overline{W}
0	1	0	A ₃	A ₂	A ₁	A ₀	R/ \overline{W}	1	0	1	A ₃	A ₂	A ₁	A ₀	R/ \overline{W}
0	1	A ₄	A ₃	A ₂	A ₁	A ₀	R/ \overline{W}	1	0	A ₄	A ₃	A ₂	A ₁	A ₀	R/ \overline{W}
0	A ₅	A ₄	A ₃	A ₂	A ₁	A ₀	R/ \overline{W}	1	A ₅	A ₄	A ₃	A ₂	A ₁	A ₀	R/ \overline{W}
A ₆	A ₅	A ₄	A ₃	A ₂	A ₁	A ₀	R/ \overline{W}	A ₆	A ₅	A ₄	A ₃	A ₂	A ₁	A ₀	R/ \overline{W}

When all address lines A1-A6 are used, the device being accessed is defined by the first byte following the address in the write transaction. If the most significant bit (MSb) of this byte is '0', this byte is treated as a command (register address) byte of the multi-port device. If the MSb is '1', this byte is the first of a 2-byte EEPROM address. In this case, the device will mask the MSb to determine the EEPROM address.

Serial EEPROM Device

EEPROM reading and writing operations require 2 bytes, AHI and ALO, which indicate which memory address to use.

To read one or more bytes, the master device addresses the unit with a write cycle (= 0) to send AHI followed by ALO, re-addresses the unit with a read cycle (= 1), and reads one or more data bytes. Each data byte read will increment the internal address counter by one up to the end of the EEPROM address space. A read or write beyond the end of the EEPROM address space should result in a NAK response by the Port Expander.

To write data to the EEPROM, the master device performs one write cycle, with the first two bytes being AHI followed by ALO. This is followed by one or more data bytes. In the case of block writing it is advisable to set the starting address on the beginning of the 64-byte boundary, for example 01C0h or 0080h, but this is not mandatory. When a 64-byte boundary is crossed in the EEPROM, the I2C clock is stretched while the device performs an EEPROM write sequence. If the end of available EEPROM space is reached, then further writes will be responded to with a NAK.

Refer to [Figure 2-2, "Memory Reading and Writing,"](#) on page 10, which illustrates memory reading and writing procedures for the EEPROM device.

Multi-Port I/O Device

This device allows the user to set various configurations and I/O operations through internal registers.

Each data transfer is preceded by the command byte. This byte is used as a pointer to a register that will receive or transmit data. Available registers are listed in [Table 3-1, "The Device Register Address Map,"](#) on page 11.

Document Conventions

Acronyms

The following table lists the acronyms that are used in this document.

Acronym	Description
AC	alternating current
DC	direct current
EEPROM	electrically erasable programmable read-only memory (E ²)
GPIO	general purpose IO
I/O	input/output
MSb	most-significant bit
POR	power on reset
PWM	pulse width modulator

Units of Measure

A units of measure table is located in the Electrical Specifications section. [Table 4-1, "Units of Measure," on page 16](#) lists all the abbreviations used in Section 4.

Numeric Naming

Hexidecimal numbers are represented with all letters in uppercase with an appended lowercase 'h' (for example, '14h' or '3Ah'). Hexidecimal numbers may also be represented by a '0x' prefix, the C coding convention. Binary numbers have an appended lowercase 'b' (e.g., '01010100b' or '01000011b'). Numbers not indicated by an 'h', 'b', or '0x' are decimal.

Table of Contents

The following is a table of contents for the remainder of this data sheet.

2. Pinouts and Pin Descriptions	5
2.1 Pinouts	5
2.1.1 28-Pin Part Pinout	5
2.1.2 48-Pin Part Pinout	6
2.1.3 100-Pin Part Pinout	7
2.2 PIN Descriptions	9
2.2.1 Extendable Soft Addressing™	9
2.2.2 Interrupt Pin (INT)	9
2.2.3 Write Disable Pin (WD)	9
2.2.4 External Reset Pin (XRES)	9
2.2.5 Working with PWMs	9
3. Register Reference	11
3.1 Register Mapping Table	11
3.2 Register Descriptions	12
3.2.1 Input Port Registers (00h - 07h)	12
3.2.2 Output Port Registers (08h - 0Fh)	12
3.2.3 Int. Status Port Registers (10h - 17h)	12
3.2.4 Port Select Register (18h)	12
3.2.5 Interrupt Mask Port Register (19h)	12
3.2.6 Select PWM Register (1Ah)	12
3.2.7 Inversion Register (1Bh)	12
3.2.8 Port Direction Register (1Ch)	12
3.2.9 Drive Mode Registers (1Dh-23h)	13
3.2.10 PWM Select Register (28h)	13
3.2.11 Config (29h)	13
3.2.12 Period Register (2Ah)	13
3.2.13 Pulse Width Register (2Bh)	13
3.2.14 Divider Register (2Ch)	13
3.2.15 Enable Register (2Dh)	13
3.2.16 Device ID/Status Register (2Eh)	14
3.2.17 Command Register (30h)	14
3.3 Commands Description	14
3.3.1 Store Config to E2 POR Defaults Cmd (01h)	14
3.3.2 Restore Factory Defaults Cmd (02h)	14
3.3.3 Write E2 POR Defaults Cmd (03h)	14
3.3.4 Read E2 POR Defaults Cmd (04h)	15
3.3.5 Write Device Config Cmd (05h)	15
3.3.6 Read Device Config Cmd (06h)	15
3.3.7 Reconfigure Device Cmd (07h)	15
4. Electrical Specifications	16
4.1 Absolute Maximum Ratings	16
4.2 Operating Temperature	17
4.3 DC Electrical Characteristics	17
4.3.1 DC Chip-Level Specifications	17
4.3.2 DC Programming Specifications	18
4.3.3 DC General Purpose I/O Specifications	18
4.4 AC Electrical Characteristics	19
4.4.1 AC General Purpose I/O Specifications	19
4.4.2 AC PWM Output Jitter Specifications	19
4.4.3 AC I2C Specifications	20
5. Packaging Information	21
5.1 Packaging Dimensions	21
5.2 Thermal Impedances	23
5.3 Solder Reflow Peak Temperature	23
6. Ordering Information	24
6.1 Ordering Code Definitions	24
7. Sales and Service Information	25
7.1 Revision History	25
7.2 Copyrights and Code Protection	25

2. Pinouts and Pin Descriptions



This chapter describes, lists, and illustrates the CY8C95xx device pins and pinout configurations, along with application examples.

2.1 Pinouts

The CY8C95xx device is available in a variety of packages, which are listed and illustrated in the following tables.

2.1.1 28-Pin Part Pinout

Table 2-1. 28-Pin Part Pinout (SSOP)

Pin No.	Pin Name	Description
1	GPort0_Bit0_PWM3	Port 0, Bit 0, PWM 3.
2	GPort0_Bit1_PWM1	Port 0, Bit 1, PWM 1.
3	GPort0_Bit2_PWM3	Port 0, Bit 2, PWM 3.
4	GPort0_Bit3_PWM1	Port 0, Bit 3, PWM 1.
5	GPort0_Bit4_PWM3	Port 0, Bit 4, PWM 3.
6	GPort0_Bit5_PWM1	Port 0, Bit 5, PWM 1.
7	GPort0_Bit6_PWM3	Port 0, Bit 6, PWM 3.
8	GPort0_Bit7_PWM1	Port 0, Bit 7, PWM 1.
9	V _{SS}	Ground connection.
10	I ² C Serial Clock (SCL)	I ² C Clock.
11	I ² C Serial Data (SDA)	I ² C Data.
12	GPort2_Bit3_PWM3/A1	Port 2, Bit 3, PWM 3, Address 1.
13	A0	Address 0.
14	V _{SS}	Ground connection.
15	GPort2_Bit2_PWM0/WD	Port 2, Bit 2, PWM 0, E ² Write Disable.
16	INT	
17	GPort2_Bit1_PWM0/A2	Port 2, Bit 1, PWM 0, Address 2.
18	GPort2_Bit0_PWM2/A3	Port 2, Bit 0, PWM 2, Address 3.
19	XRES	Active high external reset with internal pull down.
20	GPort1_Bit7_PWM0/A4	Port 1, Bit 7, PWM 0, Address 4.
21	GPort1_Bit6_PWM2/A5	Port 1, Bit 6, PWM 2, Address 5.
22	GPort1_Bit5_PWM0/A6	Port 1, Bit 5, PWM 0, Address 6.
23	GPort1_Bit4_PWM2	Port 1, Bit 4, PWM 2.
24	GPort1_Bit3_PWM0	Port 1, Bit 3, PWM 0.
25	GPort1_Bit2_PWM2	Port 1, Bit 2, PWM 2.
26	GPort1_Bit1_PWM0	Port 1, Bit 1, PWM 0.
27	GPort1_Bit0_PWM2	Port 1, Bit 0, PWM 2.
28	V _{DD}	Supply voltage.

CY8C9520 28-Pin Device

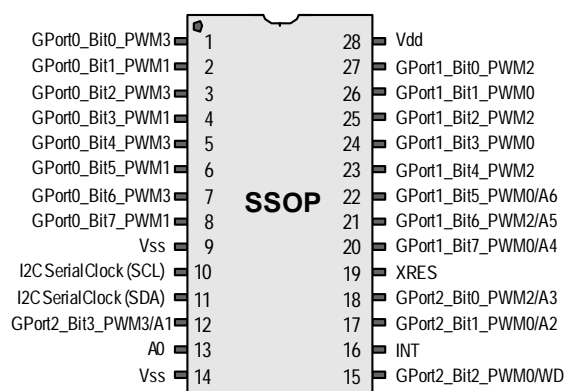

2.1.2 48-Pin Part Pinout

Table 2-2. 48-Pin Part Pinout (SSOP)

Pin No.	Pin Name	Description
1	GPort0_Bit0_PWM7	Port 0, Bit 0, PWM 7.
2	GPort0_Bit1_PWM5	Port 0, Bit 1, PWM 5.
3	GPort0_Bit2_PWM3	Port 0, Bit 2, PWM 3.
4	GPort0_Bit3_PWM1	Port 0, Bit 3, PWM 1.
5	GPort0_Bit4_PWM7	Port 0, Bit 4, PWM 7.
6	GPort0_Bit5_PWM5	Port 0, Bit 5, PWM 5.
7	GPort0_Bit6_PWM3	Port 0, Bit 6, PWM 3.
8	GPort0_Bit7_PWM1	Port 0, Bit 7, PWM 1.
9	GPort3_Bit0_PWM7	Port 3, Bit 0, PWM 7.
10	GPort3_Bit1_PWM5	Port 3, Bit 1, PWM 5.
11	GPort3_Bit2_PWM3	Port 3, Bit 2, PWM 3.
12	GPort3_Bit3_PWM1	Port 3, Bit 3, PWM 1.
13	V _{SS}	Ground connection.
14	GPort3_Bit4_PWM7	Port 3, Bit 4, PWM 7.
15	GPort3_Bit5_PWM5	Port 3, Bit 5, PWM 5.
16	GPort3_Bit6_PWM3	Port 3, Bit 6, PWM 3.
17	GPort3_Bit7_PWM1	Port 3, Bit 7, PWM 1.
18	GPort5_Bit2_PWM3	Port 5, Bit 2, PWM 3.
19	GPort5_Bit3_PWM1	Port 5, Bit 3, PWM 1.
20	I ² C Serial Clock (SCL)	I ² C Clock.
21	I ² C Serial Data (SDA)	I ² C Data.
22	GPort2_Bit3_PWM3/A1	Port 2, Bit 3, PWM 3, Address 1.
23	A0	Address 0.
24	V _{SS}	Ground connection.
25	GPort2_Bit2_PWM0/WD	Port 2, Bit 2, PWM 0, E ² Write Disable.
26	INT	
27	GPort2_Bit1_PWM4/A2	Port 2, Bit 1, PWM 4, Address 2.
28	GPort2_Bit0_PWM6/A3	Port 2, Bit 0, PWM 6, Address 3.
29	GPort5_Bit1_PWM0	Port 5, Bit 1, PWM 0.
30	GPort5_Bit0_PWM2	Port 5, Bit 0, PWM 2.
31	GPort4_Bit7_PWM0	Port 4, Bit 7, PWM 0.
32	GPort4_Bit6_PWM2	Port 4, Bit 6, PWM 2.
33	GPort4_Bit5_PWM4	Port 4, Bit 5, PWM 4.
34	GPort4_Bit4_PWM6	Port 4, Bit 4, PWM 6.
35	XRES	Active high external reset with internal pull down.
36	GPort4_Bit3_PWM0	Port 4, Bit 3, PWM 0.
37	GPort4_Bit2_PWM2	Port 4, Bit 2, PWM 2.
38	GPort4_Bit1_PWM4	Port 4, Bit 1, PWM 4.
39	GPort4_Bit0_PWM6	Port 4, Bit 0, PWM 6.
40	GPort1_Bit7_PWM0/A4	Port 1, Bit 7, PWM 0, Address 4.
41	GPort1_Bit6_PWM2/A5	Port 1, Bit 6, PWM 2, Address 5.
42	GPort1_Bit5_PWM4/A6	Port 1, Bit 5, PWM 4, Address 6.
43	GPort1_Bit4_PWM6	Port 1, Bit 4, PWM 6.
44	GPort1_Bit3_PWM0	Port 1, Bit 3, PWM 0.
45	GPort1_Bit2_PWM2	Port 1, Bit 2, PWM 2.
46	GPort1_Bit1_PWM4	Port 1, Bit 1, PWM 4.
47	GPort1_Bit0_PWM6	Port 1, Bit 0, PWM 6.
48	V _{DD}	Supply voltage.

CY8C9540 48-Pin Device

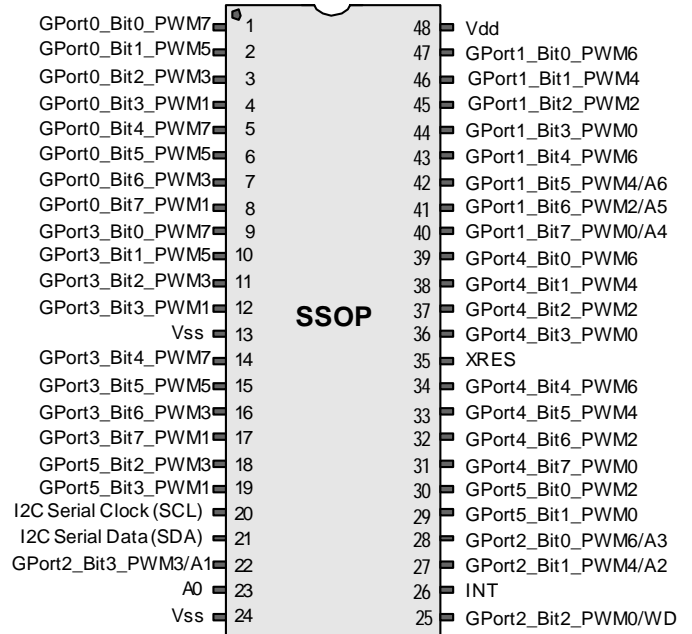

2.1.3 100-Pin Part Pinout

Table 2-3. 100-Pin Part Pinout (TQFP)

Pin No.	Name	Description	Pin No.	Name	Description
1	DNU	DNU = Do Not Use; leave floating.	51	DNU	DNU = Do Not Use; leave floating.
2	DNU	DNU = Do Not Use; leave floating.	52	GPort5_Bit1_PWM8	Port 5, Bit 1, PWM 8.
3	GPort0_Bit3_PWM1	Port 0, Bit 3, PWM 1.	53	GPort5_Bit0_PWM10	Port 5, Bit 0, PWM 10.
4	GPort0_Bit4_PWM7	Port 0, Bit 4, PWM 7.	54	GPort5_Bit4_PWM12	Port 5, Bit 4, PWM 12.
5	GPort0_Bit5_PWM5	Port 0, Bit 5, PWM 5.	55	GPort5_Bit5_PWM14	Port 5, Bit 5, PWM 14.
6	GPort0_Bit6_PWM3	Port 0, Bit 6, PWM 3.	56	GPort4_Bit7_PWM8	Port 4, Bit 7, PWM 8.
7	GPort0_Bit7_PWM1	Port 0, Bit 7, PWM 1.	57	GPort4_Bit6_PWM10	Port 4, Bit 6, PWM 10.
8	GPort3_Bit0_PWM7	Port 3, Bit 0, PWM 7.	58	GPort4_Bit5_PWM12	Port 4, Bit 5, PWM 12.
9	GPort3_Bit1_PWM5	Port 3, Bit 1, PWM 5.	59	GPort4_Bit4_PWM14	Port 4, Bit 4, PWM 14.
10	GPort3_Bit2_PWM3	Port 3, Bit 2, PWM 3.	60	DNU	DNU = Do Not Use; leave floating.
11	GPort3_Bit3_PWM1	Port 3, Bit 3, PWM 1.	61	DNU	DNU = Do Not Use; leave floating.
12	DNU	DNU = Do Not Use; leave floating.	62	XRES	Active high external reset with internal pull down.
13	DNU	DNU = Do Not Use; leave floating.	63	GPort4_Bit3_PWM0	Port 4, Bit 3, PWM 0.
14	DNU	DNU = Do Not Use; leave floating.	64	GPort4_Bit2_PWM2	Port 4, Bit 2, PWM 2.
15	V _{SS}	Ground connection.	65	V _{SS}	Ground connection.
16	GPort3_Bit4_PWM15	Port 3, Bit 4, PWM 15.	66	GPort4_Bit1_PWM4	Port 4, Bit 1, PWM 4.
17	GPort3_Bit5_PWM13	Port 3, Bit 5, PWM 13.	67	GPort4_Bit0_PWM6	Port 4, Bit 0, PWM 6.
18	GPort3_Bit6_PWM11	Port 3, Bit 6, PWM 11.	68	GPort1_Bit7_PWM0/A4	Port 1, Bit 7, PWM 0, Address 4.
19	GPort3_Bit7_PWM9	Port 3, Bit 7, PWM 9.	69	GPort1_Bit6_PWM2/A5	Port 1, Bit 6, PWM 2, Address 5.
20	GPort5_Bit7_PWM15	Port 5, Bit 7, PWM 15.	70	GPort1_Bit5_PWM4/A6	Port 1, Bit 5, PWM 4, Address 6.
21	GPort5_Bit6_PWM13	Port 5, Bit 6, PWM 13.	71	DNU	DNU = Do Not Use; leave floating.
22	GPort5_Bit2_PWM11	Port 5, Bit 2, PWM 11.	72	GPort1_Bit4_PWM6	Port 1, Bit 4, PWM 6.
23	GPort5_Bit3_PWM9	Port 5, Bit 3, PWM 9.	73	DNU	DNU = Do Not Use; leave floating.
24	I ² C Serial Clock (SCL)	I ² C Clock.	74	GPort1_Bit3_PWM0	Port 1, Bit 3, PWM 0.
25	DNU	DNU = Do Not Use; leave floating.	75	DNU	DNU = Do Not Use; leave floating.
26	DNU	DNU = Do Not Use; leave floating.	76	DNU	DNU = Do Not Use; leave floating.
27	DNU	DNU = Do Not Use; leave floating.	77	GPort1_Bit2_PWM2	Port 1, Bit 2, PWM 2.
28	I ² C Serial Data (SDA)	I ² C Data.	78	DNU	DNU = Do Not Use; leave floating.
29	GPort2_Bit3_PWM11/A1	Port 2, Bit 3, PWM 11, Address 1.	79	GPort1_Bit1_PWM4	Port 1, Bit 1, PWM 4.
30	A0	Address 0.	80	DNU	DNU = Do Not Use; leave floating.
31	DNU	DNU = Do Not Use; leave floating.	81	GPort1_Bit0_PWM6	Port 1, Bit 0, PWM 6.
32	V _{dd}	Supply voltage.	82	V _{dd}	Supply voltage.
33	DNU	DNU = Do Not Use; leave floating.	83	V _{dd}	Supply voltage.
34	V _{SS}	Ground connection.	84	V _{SS}	Ground connection.
35	DNU	DNU = Do Not Use; leave floating.	85	V _{SS}	Ground connection.
36	GPort7_Bit7_PWM15	Port 7, Bit 7, PWM 15.	86	GPort6_Bit0_PWM0	Port 6, Bit 0, PWM 0.
37	GPort7_Bit6_PWM14	Port 7, Bit 6, PWM 14.	87	GPort6_Bit1_PWM1	Port 6, Bit 1, PWM 1.
38	GPort7_Bit5_PWM13	Port 7, Bit 5, PWM 13.	88	GPort6_Bit2_PWM2	Port 6, Bit 2, PWM 2.
39	GPort7_Bit4_PWM12	Port 7, Bit 4, PWM 12.	89	GPort6_Bit3_PWM3	Port 6, Bit 3, PWM 3.
40	GPort7_Bit3_PWM11	Port 7, Bit 3, PWM 11.	90	GPort6_Bit4_PWM4	Port 6, Bit 4, PWM 4.
41	GPort7_Bit2_PWM10	Port 7, Bit 2, PWM 10.	91	GPort6_Bit5_PWM5	Port 6, Bit 5, PWM 5.
42	GPort7_Bit1_PWM9	Port 7, Bit 1, PWM 9.	92	GPort6_Bit6_PWM6	Port 6, Bit 6, PWM 6.
43	GPort7_Bit0_PWM8	Port 7, Bit 0, PWM 8.	93	GPort6_Bit7_PWM7	Port 6, Bit 7, PWM 7.
44	GPort2_Bit2_PWM8/WD	Port 2, Bit 2, PWM 8, E ² Write Disable.	94	DNU	DNU = Do Not Use; leave floating.
45	INT		95	GPort0_Bit0_PWM7	Port 0, Bit 0, PWM 7.
46	GPort2_Bit1_PWM12/A2	Port 2, Bit 1, PWM 12, Address 2.	96	DNU	DNU = Do Not Use; leave floating.
47	GPort2_Bit0_PWM14/A3	Port 2, Bit 0, PWM 14, Address 3.	97	GPort0_Bit1_PWM5	Port 0, Bit 1, PWM 5.
48	DNU	DNU = Do Not Use; leave floating.	98	DNU	DNU = Do Not Use; leave floating.
49	DNU	DNU = Do Not Use; leave floating.	99	GPort0_Bit2_PWM3	Port 0, Bit 2, PWM 3.
50	DNU	DNU = Do Not Use; leave floating.	100	DNU	DNU = Do Not Use; leave floating.

CY8C9560 100-Pin Device

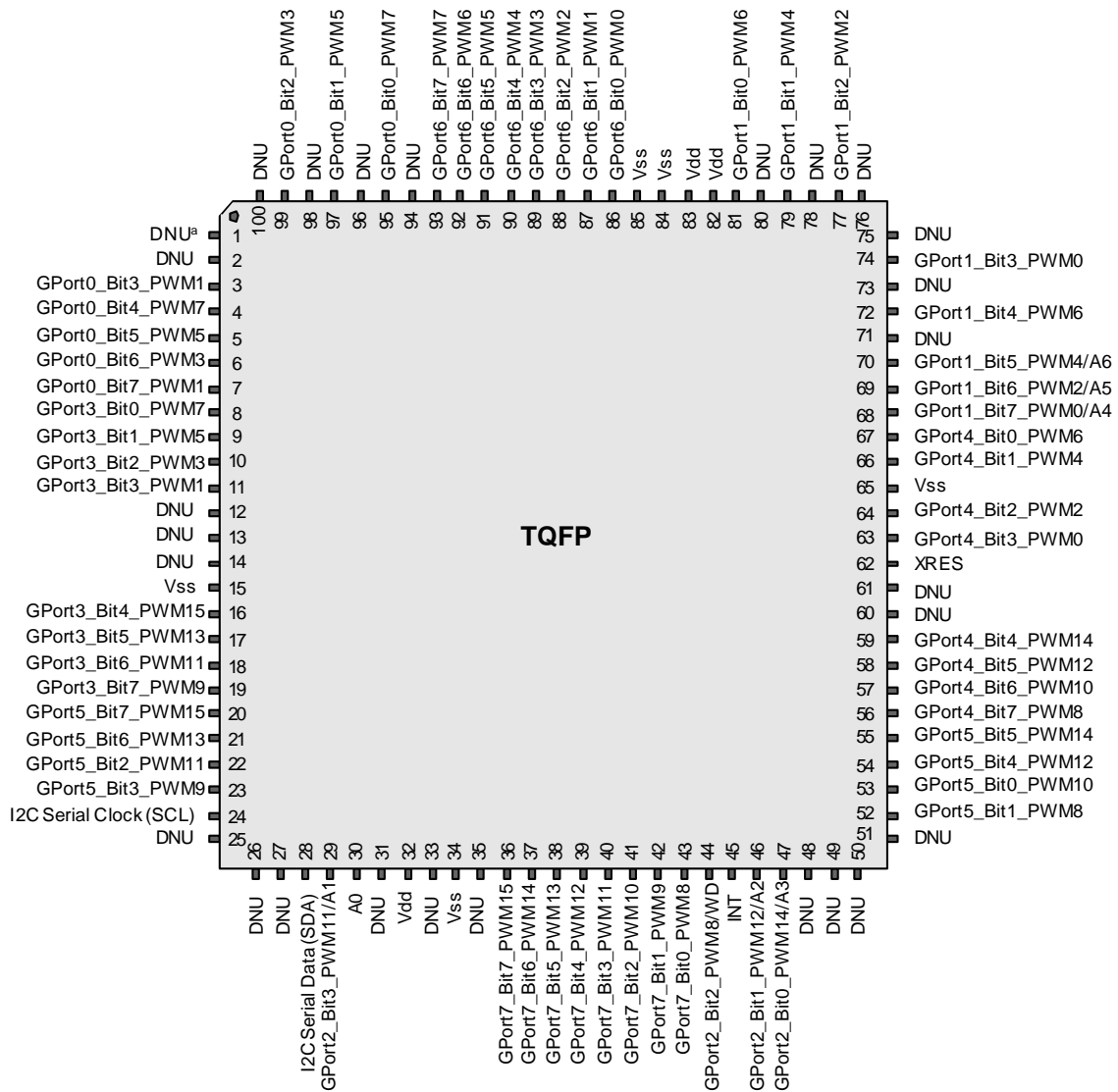

a.) DNU = Do Not Use; leave floating.

2.2 PIN Descriptions

2.2.1 Extendable Soft Addressing™

The A0 line is always used to define the corresponding bit of the I2C address. This pin should be pulled up or down. If A0 is a strong pull-up or a strong pull-down (wired through 330 or less resistor to Vdd or Vss), then that is the only address line being specified and the A1-A6 lines are used as GPIO. If A0 is a weak pull-up or a weak pull-down (connected to Vdd or Vss through 75K- 200K-ohm resistor), then A0 is not the only externally defined address bit. There is a pin assigned to be A1 if it is needed. This pin can be pulled-up or pulled-down strong or weak with a resistor. As with A0, the type of pull determines whether the address bit is the last externally defined address bit. Differently from A0, A1 is not dedicated as an address pin. It is only used if A0 is not the only address bit externally defined. There are also predefined pins for A2, A3, A4, A5 and A6 that will only be used for addressing if needed. The last address bit in the chain is pulled strong. That way, only the number of pins needed to assign the address desired for the part are allocated as address pins, any pins not used for address bits are available to be used as GPIO pins. The Table , “Device Addressing,” on page 3 defines the resulting device I2C address.

2.2.2 Interrupt Pin (INT)

The interrupt output (if enabled) is activated if one of the following events occurs:

- One of the GPIO port pins changes state and the corresponding bit in the Interrupt Mask register is set low.
- When a PWM driven by the slowest clock source (367.6 Hz) and assigned to a pin changes state and the pin's corresponding bit in the Interrupt Mask register is set low.

The interrupt line is deactivated when the master device performs a read from the corresponding Interrupt Status register.

2.2.3 Write Disable Pin (WD)

If this feature is enabled, '0' allows writes to the EEPROM and '1' blocks any memory writes. This pin is checked immediately before performing any write to memory. If the EEE bit in the Enable register is not set (EEPROM disabled) or bit EERO is set (EEPROM is read-only) then WD line level is ignored.

Note that '1' on this line blocks all commands which perform operations with EEPROM (see Table 3-9, “Available Commands,” on page 14).

This line may be enabled/disabled by bit 1 of the Enable register (2Dh): '1' enables WD function, '0' disables.

2.2.4 External Reset Pin (XRES)

A full device reset is caused by pulling the XRES pin high. The XRES pin has an always-on pull-down resistor, so it does not require an external pull down for operation. It can be tied directly to ground or left open. Behavior after XRES is similar to POR.

2.2.5 Working with PWMs

There are four independent PWMs in the CY8C9520, eight in the CY8C9540 and sixteen in the CY8C9560. Each I/O pin can be configured as a PWM output by writing '1' to the corresponding bit of the Select PWM register (see Table 3-2, “Output and Select PWM Registers Logic,” on page 127).

The next step of PWM configuration is clock source selection using the Config PWM registers. There are six available clock sources: 32 kHz (default), 24 MHz, 1.5 MHz, 93.75 kHz, 367.6 Hz or previous PWM output. (see Figure 2-1).

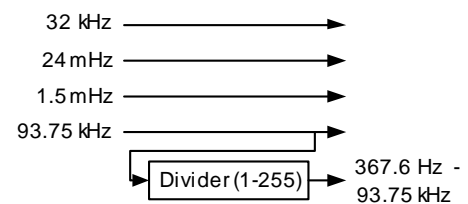

Figure 2-1. Clock Sources

By default, 32 kHz is selected as the PWM clock.

PWM Period registers are used to set the output period:

$$t_{OUT} = Period \times t_{CLK} \quad \text{Equation 1}$$

Allowed values are between 1 and FFh.

The PWM Pulse Width register sets the duration of the PWM output pulse. Allowed values are between zero and the (Period-1) value. The duty cycle ratio can be computed using the following equation:

$$DutyCycle = \frac{PulseWidth}{Period} \quad \text{Equation 2}$$

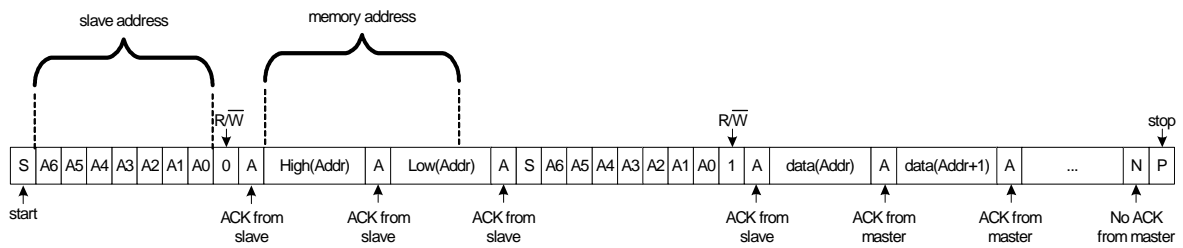

Reading from EEPROM

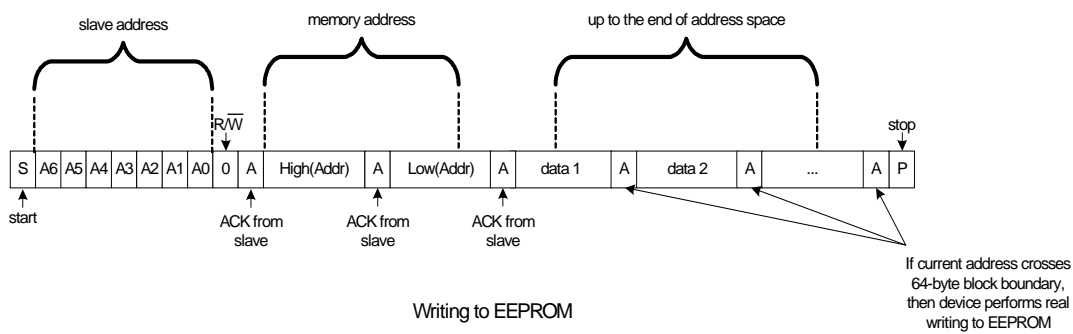

Writing to EEPROM

Figure 2-2. Memory Reading and Writing

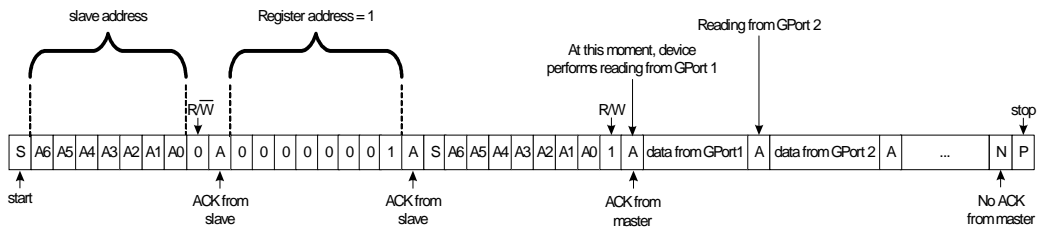

Reading from GPort 1

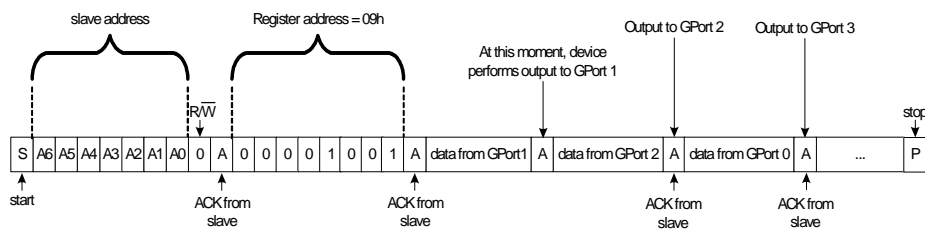

Writing from GPort 1

Figure 2-3. Port Reading and Writing in Multi-Port Device

3. Register Reference



This chapter lists and describes the registers of the CY8C95xx device, starting with a register map and then detailed descriptions of register types.

3.1 Register Mapping Table

The register address is auto-incrementing. If the master device writes or reads data to or from one register and then continues data transfer in the same I2C transaction, sequential bytes will be written or read to or from the following registers. For example, if the first byte is sent to the Output Port 1 register, then the next bytes will be written to Output Port 2, Output Port 3, Output Port 4 etc. The first byte of each write transaction is treated as the register address.

To read data from a series of registers, the master device should write the starting register address byte then perform a start and series of read transactions. If no address was sent, reads start from address 0.

To read a specific register address, the master device should write the register address byte, then perform a start and read transaction.

See Figure 1-3, "Port Reading and Writing in Multi-Port Device," on page 11.

The device's register mapping is listed in Table 3-1.

Table 3-1. The Device Register Address Map

Address	Register	Default Register Value
00h	Input Port 0	None
01h	Input Port 1	None
02h	Input Port 2	None
03h	Input Port 3	None
04h	Input Port 4	None
05h	Input Port 5	None
06h	Input Port 6	None
07h	Input Port 7	None
08h	Output Port 0	FFh
09h	Output Port 1	FFh
0Ah	Output Port 2	FFh
0Bh	Output Port 3	FFh
0Ch	Output Port 4	FFh
0Dh	Output Port 5	FFh
0Eh	Output Port 6	FFh
0Fh	Output Port 7	FFh
10h	Interrupt Status Port 0	00h
11h	Interrupt Status Port 1	00h
12h	Interrupt Status Port 2	00h

Table 3-1. The Device Register Address Map (continued)

Address	Register	Default Register Value
13h	Interrupt Status Port 3	00h
14h	Interrupt Status Port 4	00h
15h	Interrupt Status Port 5	00h
16h	Interrupt Status Port 6	00h
17h	Interrupt Status Port 7	00h
18h	Port Select	00h
19h	Interrupt Mask	FFh
1Ah	Select PWM for Port Output	00h
1Bh	Inversion	00h
1Ch	Pin Direction - Input/Output	00h
1Dh	Drive Mode - Pull Up	FFh
1Eh	Drive Mode - Pull Down	00h
1Fh	Drive Mode - Open Drain High	00h
20h	Drive Mode - Open Drain Low	00h
21h	Drive Mode - Strong	00h
22h	Drive Mode - Slow Strong	00h
23h	Drive Mode - High-Z	00h
24h	Reserved	None
25h	Reserved	None
26h	Reserved	None
27h	Reserved	None
28h	PWM Select	00h
29h	Config PWM	00h
2Ah	Period PWM	FFh
2Bh	Pulse Width PWM	80h
2Ch	Programmable Divider	FFh
2Dh	Enable WDE, EEE, EERO	00h
2Eh	Device ID/Status	20h/40h/60h
2Fh	Reserved	None
30h	Command	00h

3.2 Register Descriptions

The registers for the CY8C95xx are described in the sections that follow. Note that the PWM registers are located at addresses 28h to 2Bh.

3.2.1 Input Port Registers (00h - 07h)

These registers represent actual logical levels on the pins and are used for I/O port reading operations. They are read-only.

The Inversion registers will change the state of reads to these ports.

3.2.2 Output Port Registers (08h - 0Fh)

These registers are used for writing data to GPIO ports. By default, all ports are in the pull-up mode allowing quasi-bidirectional I/O. To allow input operations without reconfiguration, these registers have to store '1's.

Output register data also affects pin states when PWMs are enabled. See [Table 3-2. Output and Select PWM Registers Logic](#) for details.

[Figure 2-3 on page 10](#) illustrates port read/write procedures.

The Inversion registers have no effect on these ports.

3.2.3 Int. Status Port Registers (10h - 17h)

Each '1' bit in these registers signals that there has been a change in the corresponding input line since the last read of that Interrupt Status register. Each Interrupt (Int.) Status register is cleared only after a read of that register.

If a PWM is assigned to a pin, then all state changes of the PWM will set the corresponding bit in the Interrupt Status register. If the pin's interrupt mask is cleared and the PWM is set to the slowest possible rate allowed (driven by the programmable clock source with divide register 2Dh set to FFh), then the INT line will also be driven on the PWM state change.

3.2.4 Port Select Register (18h)

This register is used to select the GPort to be configured. Write a value of 0-7 to this register to select the port to program with the following registers, 19h-23h.

3.2.5 Interrupt Mask Port Register (19h)

The Interrupt Mask register enables/disables activation of the INT line when GPIO input levels are changed. Each '1' in the Interrupt Mask register masks (disables) interrupts generated from the corresponding input line of the GPort selected by the Port Select register (18h).

3.2.6 Select PWM Register (1Ah)

This register is used to allow each port to act as a PWM output. By default, all ports are configured as GPIO lines. Each '1' in this register connects the corresponding pin of the GPort selected by the Port Select register (18h) to the PWM output. Output register data also affects the pin state when a PWM is enabled. See [Table 3-2](#).

Note that a pin used as PWM output should be configured to the appropriate drive mode. See [Table 3-4 on page 13](#) for more information.

[Table 3-2](#) describes the logic of the Output and Select PWM registers.

Table 3-2. Output and Select PWM Registers Logic

Output	Select PWM	Pin State
0	0	0
1	0	1
0	1	0
1	1	Current PWM

3.2.7 Inversion Register (1Bh)

This register can invert the logic of the input ports. Each '1' written to this register inverts the logic of the corresponding bit in the Input register of the GPort selected by the Port Select register (18h).

The Input registers' logic is presented in [Table 3-3](#).

These registers have no effect on outputs or PWMs.

Table 3-3. Inversion Register Logic

Pin State	Invert	Input
0	0	0
1	0	1
0	1	1
1	1	0

3.2.8 Port Direction Register (1Ch)

Each bit in a port can be configured as either an input or an output. To perform this configuration, the Port Direction register (1Ch) is used for the GPort selected by the Port Select register (18h). If a bit in this register is set (written with '1'), the corresponding port pin is enabled as an input. If a bit in this register is cleared (written with '0'), the corresponding port pin is enabled as an output.

3.2.9 Drive Mode Registers (1Dh-23h)

Each port's data pins can be set separately to one of seven available modes: pull-up/-down, open drain high/low, strong drive fast/slow, or high-impedance input. To perform this configuration, the seven drive mode registers are used for the GPort selected by the Port Select register (18h). Each '1' written to this register changes the corresponding line drive mode. Registers 1Dh through 23h have last-register priority meaning that the bit set to high in which the last register was written will override those that came before. Reading these registers reflects the actual setting, not what was originally written.

Table 3-4. Drive Mode Register Settings

Register	Pin State	Description
1Dh	Resistive pull up	Resistive high, strong low (default)
1Eh	Resistive pull down	Strong high, resistive low
1Fh	Open drain high	Slow strong high, High-Z low
20h	Open drain low	Slow strong low, High-Z high
21h	Strong drive	Strong high, strong low, fast output mode
22h	Slow strong drive	Strong high, strong low, slow output mode
23h	High impedance	High-Z

3.2.10 PWM Select Register (28h)

This register is used to select the PWM to be configured. Write a value of 00h-0Fh to this register to select the PWM to program with the following registers, 29h-2Bh.

3.2.11 Config (29h)

This register is used to choose the clock source for the PWM selected by the PWM Select register (28h) and interrupt logic.

There are six available clock sources: 32 kHz (default), 24 MHz, 1.5 MHz, 93.75 kHz, 367.6 Hz, or previous PWM output. The 367.6 Hz clock is user programmable. It divides the 93.75 kHz clock source by the divisor stored in the Divider register (2Ch). The default divide ratio is 255. (see [Table 3-5](#) for details). By default, all PWMs are clocked from 32 kHz.

Table 3-5. PWM Clock Sources

Config PWM	PWM Clock Source
xxxx000b	32 kHz (default)
xxxx001b	24 MHz
xxxx010b	1.5 MHz
xxxx011b	93.75 kHz
xxxx100b	367.6 Hz (programmable)
xxxx101b	Previous PWM

Each PWM can generate an interrupt at the rising or falling edge of the output pulse. There is a limitation on the clock source for a PWM to generate an interrupt. Only the slowest speed source (programmed to 367.6 Hz) with the divider equal to 255 allows interrupt generation. Consequently, to create a PWM interrupt, it is necessary to choose the programmable divider output as the clock source (write xxxxx100b to Config register (29h)), write 255 to the Divide register (2Ch), and select PWM for pin output (1Ah).

Interrupt status is reflected in the Interrupt Status registers (10h-17h) and can cause INT line activation if enabled by the corresponding mask bit in the Interrupt Mask register:

3.2.12 Period Register (2Ah)

Table 3-6. Period Register

Config PWM	PWM Interrupt on
xxxx0xxx	Falling pulse edge (default)
xxxx1xxx	Rising pulse edge

This register sets the period of the PWM counter. Allowed values are between 1 and FFh. The effective output waveform period of the PWM is:

$$t_{OUT} = Period \cdot t_{CLK}$$

3.2.13 Pulse Width Register (2Bh)

This register sets the pulse width of the PWM output. Allowed values are between zero and the (Period - 1) value. The duty cycle ratio can be computed using the following equation:

$$DutyCycle = \frac{PulseWidth}{Period}$$

3.2.14 Divider Register (2Ch)

This register sets the frequency on the output of the programmable divider:

$$Frequency = \frac{93.75 \text{ kHz}}{Divider}$$

Allowed values are between 1 and 255.

3.2.15 Enable Register (2Dh)

The WDE bit configures the write disable pin to operate either as a GPIO or as WD. It also enables/disables EEPROM operations (EEE bit) or makes the EEPROM read-only (EERO bit). Bit assignments are shown in [Table 3-7](#) on page 14.

Each '1' enables the corresponding feature, '0' disables.

Table 3-7. Enable Register

Bit	7	6	5	4	3	2	1	0
Function	Reserved					EERO	EEE	WDE
Default	Reserved					0	0	0

Writes to this register differ from other registers. The write sequence to modify the Enable register is as follows:

1. Send device I2C address with bit 0.
2. Send register address 2Dh.
3. Send unlock key - the sequence of three bytes: 43h, 4Dh, 53h; ('C', 'M', 'S' in ASCII bytes).
4. Send new Enable register value.

This write sequence secures the register from accidental changes. The register can be read without the use of the unlock key.

By default, EERO and EEPROM (EEE bit) are disabled and WD line (WDE bit) is set to GPIO (WD disabled).

When performing a burst write operation that crosses this register, the data written to this register will be ignored and the address will increment to 2Eh.

3.2.16 Device ID/Status Register (2Eh)

This register stores device identifiers (2xh/4xh/6xh) and reflects which settings were loaded during startup, either factory defaults (FD) or user defaults (UD). By default during startup, the device will attempt to load the user default block. If it seems to be corrupted then factory defaults are loaded and the low nibble of this register is set high to inform which set is active. The high nibble is always equal to 2 for CY8C9520, 4 for CY8C9540, and 6 for CY8C9560.

This register is read-only.

Table 3-8. Device ID Status Register

Bit	7	8	5	4	3	2	1	0
Function	Device Family (2, 4, or 6)				Reserved			FD/ \overline{UD}

3.2.17 Command Register (30h)

This register sends commands to the device, including current configuration as new POR defaults, restore factory defaults, define POR defaults, read POR defaults, write device configuration, read device configuration, and reconfigure device with stored POR defaults. The command set is presented in [Table 3-9](#).

Note that registers are not restored in parallel. Do not assume any particular order to the restoration process.

Table 3-9. Available Commands

Command	Description
01h	Store device configuration to EEPROM POR defaults
02h	Restore Factory Defaults
03h	Write EEPROM POR defaults
04h	Read EEPROM POR defaults
05h	Write device configuration
06h	Read device configuration
07h	Reconfigure device with stored POR defaults

3.3 Commands Description

3.3.1 Store Config to E² POR Defaults Cmd (01h)

The current ports settings (drive modes and output data) and other configuration registers are saved in the EEPROM by using the store configuration command (Cmd). These settings will be automatically loaded after the next device power-up or if the 07h command is issued.

3.3.2 Restore Factory Defaults Cmd (02h)

This command replaces the saved user configuration with the factory default configuration. Current settings are unaffected by this command. New settings will be loaded after the next device power-up or if the 07h command is issued.

3.3.3 Write E² POR Defaults Cmd (03h)

This command is used to send new power-up defaults to the CY8C95xx without changing current settings unless the 07h command is issued afterwards. This command is followed by 147 data bytes according to [Table 3-10](#). The CRC is calculated as the XOR of the 146 data bytes (00h-91h). If the CRC check fails or an incomplete block is sent, then the slave will respond with a NAK and the data will not be saved to EEPROM.

To define new POR defaults the user must:

- Write command 03h;
- Write 146 data bytes with new values of registers;
- Write 1 CRC byte calculated as XOR of previous 146 data bytes.

Content of the data block is described in [Table 3-10](#).

Table 3-10. POR Defaults Data Structure

Offset	Value
00h – 07h	Output Port 0-7
08h – 0Fh	Interrupt mask Port 0-7
10h – 17h	Select PWM Port 0-7
18h – 1Fh	Inversion Port 0-7
20h – 27h	Pin Direction Port 0-7
28h	Resistive pull up Drive Mode Port 0
29h	Resistive pull down Drive Mode Port 0
2Ah	Open drain high Drive Mode Port 0
2Bh	Open drain low Drive Mode Port 0
2Ch	Strong drive Drive Mode Port 0
2Dh	Slow strong drive Drive Mode Port 0
2Eh	High impedance Drive Mode Port 0
2Fh – 35h	Drive Modes Port 1
36h – 3Ch	Drive Modes Port 2
3Dh – 43h	Drive Modes Port 3
44h – 4Ah	Drive Modes Port 4
4Bh – 51h	Drive Modes Port 5
52h – 58h	Drive Modes Port 6
59h – 5Fh	Drive Modes Port 7
60h	Config setting PWM0
61h	Period setting PWM0
62h	Pulse Width setting PWM0
63h – 65h	PWM1 settings
...	...
8Dh – 8Fh	PWM15 settings
90h	Divider
91h	Enable
92h	CRC

3.3.4 Read E2 POR Defaults Cmd (04h)

This command is used to read the POR settings stored in the EEPROM.

To read POR defaults the user must:

- Write command 04h;
- Read 146 data bytes (see [Table 3-10](#)).
- Read 1 CRC byte.

3.3.5 Write Device Config Cmd (05h)

This command is used to send a new device configuration to the CY8C95xx. It is followed by 146 data bytes according to [Table 3-10](#). The CRC is calculated as the XOR of the 146 data bytes (00h-91h). If the CRC check fails or an incomplete block is sent, then the slave will respond with a NAK and the device will not use the data. This gives the user 'flat-address-space' access to all device settings.

To set the current device configuration the user must:

- Write command 05h;
- Write 146 data bytes with new values of registers;
- Write 1 CRC byte calculated as XOR of previous 146 data bytes.

If the CRC check passes, then the device will use the new settings immediately.

Content of the data block is described in [Table 3-10](#).

3.3.6 Read Device Config Cmd (06h)

This command is used to read the current device configuration. It gives the user 'flat-address-space' access to all device settings.

To read device configuration the user must:

- Write command 06h;
- Read 146 data bytes (see [Table 3-10](#)).
- Read 1 CRC byte.

3.3.7 Reconfigure Device Cmd (07h)

This command is used to immediately reconfigure the device with actual POR defaults from EEPROM. It has the same effect on the registers as a POR.

4. Electrical Specifications



This chapter presents the DC and AC electrical specifications of the CY8C95xx device. For the most up to date electrical specifications, confirm that you have the most recent data sheet by going to the web at <http://www.cypress.com/psoc>.

Specifications are valid for $-40^{\circ}\text{C} \leq T_A \leq 85^{\circ}\text{C}$ and $T_J \leq 100^{\circ}\text{C}$, except where noted.

The following table lists the units of measure that are used in this chapter.

Table 4-1: Units of Measure

Symbol	Unit of Measure	Symbol	Unit of Measure
$^{\circ}\text{C}$	degree Celsius	mA	milli-ampere
kHz	kilohertz	nA	nanoampere
MHz	megahertz	ns	nanosecond
μs	microsecond	pF	picofarad
μV	microvolts	V	volts
μV_{rms}	microvolts root-mean-square		

4.1 Absolute Maximum Ratings

Table 4-2: Absolute Maximum Ratings

Symbol	Description	Min	Typ	Max	Units	Notes
T_{STG}	Storage Temperature	-45	–	+100	$^{\circ}\text{C}$	Higher storage temperatures will reduce data retention time.
T_A	Ambient Temperature with Power Applied	-40	–	+85	$^{\circ}\text{C}$	
Vdd	Supply Voltage on Vdd Relative to Vss	-0.5	–	+6.0	V	
V_{IO}	DC Input Voltage	Vss - 0.5	–	Vdd + 0.5	V	
V_{IOZ}	DC Voltage Applied to Tri-state	Vss - 0.5	–	Vdd + 0.5	V	
I_{MIO}	Maximum Current into any Port Pin	-25	–	+50	mA	
ESD	Electro Static Discharge Voltage	2000	–	–	V	Human Body Model ESD.
LU	Latch-up Current	–	–	200	mA	

4.2 Operating Temperature

Table 4-3: Operating Temperature

Symbol	Description	Min	Typ	Max	Units	Notes
T _A	Ambient Temperature	-40	–	+85	°C	
T _J	Junction Temperature	-40	–	+100	°C	The temperature rise from ambient to junction is package specific. See "Thermal Impedances" on page 23. The user must limit the power consumption to comply with this requirement.

4.3 DC Electrical Characteristics

4.3.1 DC Chip-Level Specifications

The following table lists guaranteed maximum and minimum specifications for the voltage and temperature ranges: 4.75V to 5.25V and $-40^{\circ}\text{C} \leq T_A \leq 85^{\circ}\text{C}$, or 3.0V to 3.6V and $-40^{\circ}\text{C} \leq T_A \leq 85^{\circ}\text{C}$, respectively. Typical parameters apply to 5V and 3.3V at 25°C and are for design guidance only.

Table 4-4: CY8C9520 DC Chip-Level Specifications

Symbol	Description	Min	Typ	Max	Units	Notes
V _{DD}	Supply Voltage	3.00	–	5.25	V	
I _{DD}	Supply Current V _{DD} 5V	–	3.8	5	mA	Conditions are 5.0V, T _A = 25 °C, IOH = 0.
I _{DD3}	Supply Current V _{DD} 3.3V	–	2.3	3	mA	Conditions are 3.3V, T _A = 25 °C, IOH = 0.

Table 4-5: CY8C9540 DC Chip-Level Specifications

Symbol	Description	Min	Typ	Max	Units	Notes
V _{DD}	Supply Voltage	3.00	–	5.25	V	
I _{DD}	Supply Current V _{DD} 5V	–	6	9	mA	Conditions are 5.0V, T _A = 25 °C, IOH = 0.
I _{DD3}	Supply Current V _{DD} 3.3V	–	3.3	6	mA	Conditions are 3.3V, T _A = 25 °C, IOH = 0.

Table 4-6: CY8C9560 DC Chip-Level Specifications

Symbol	Description	Min	Typ	Max	Units	Notes
V _{DD}	Supply Voltage	3.00	–	5.25	V	
I _{DD}	Supply Current V _{DD} 5V	–	15	25	mA	Conditions are 5.0V, T _A = 25 °C, IOH = 0.
I _{DD3}	Supply Current V _{DD} 3.3V	–	5	9	mA	Conditions are 3.3V, T _A = 25 °C, IOH = 0.

4.3.2 DC Programming Specifications

The following table lists guaranteed maximum and minimum specifications for the voltage and temperature ranges: 4.75V to 5.25V and $-40^{\circ}\text{C} \leq T_A \leq 85^{\circ}\text{C}$, or 3.0V to 3.6V and $-40^{\circ}\text{C} \leq T_A \leq 85^{\circ}\text{C}$, respectively. Typical parameters apply to 5V and 3.3V at 25°C and are for design guidance only.

Table 4-7. DC Programming Specifications

Symbol	Description	Min	Typ	Max	Units	Notes
Flash _{ENPB}	Flash (EEPROM) Endurance (per block)	50,000	–	–	–	Erase/write cycles per block.
Flash _{ENT}	Flash Endurance (total) ¹	1,800,000	–	–	–	Erase/write cycles.
Flash _{DR}	Flash Data Retention	10	–	–	Years	

1. A maximum of 36 x 50,000 block endurance cycles is allowed. This may be balanced between operations on 36x1 blocks of 50,000 maximum cycles each, 36x2 blocks of 25,000 maximum cycles each, or 36x4 blocks of 12,500 maximum cycles each (to limit the total number of cycles to 36x50,000 and that no single block ever sees more than 50,000 cycles).

4.3.3 DC General Purpose I/O Specifications

The following table lists guaranteed maximum and minimum specifications for the voltage and temperature ranges: 4.75V to 5.25V and $-40^{\circ}\text{C} \leq T_A \leq 85^{\circ}\text{C}$, or 3.0V to 3.6V and $-40^{\circ}\text{C} \leq T_A \leq 85^{\circ}\text{C}$, respectively. Typical parameters apply to 5V and 3.3V at 25°C and are for design guidance only.

Table 4-8: DC GPIO Specifications

Symbol	Description	Min	Typ	Max	Units	Notes
V _{OH}	High Output Level	V _{DD} - 1.0	–	–	V	IOH = 10 mA for any one pin, V _{DD} = 4.75 to 5.25V. 40 mA maximum combined IOH for GPort0; GPort2_Bit3; GPort3; GPort5_Bit2, 3, 6, 7; GPort6. 40 mA maximum combined IOH for GPort1; GPort2_Bit0, 1, 2; GPort4; GPort5_Bit0, 1, 4, 5; GPort7. 80 mA maximum combined IOH.
V _{OL}	Low Output Level	–	–	0.75	V	IOL = 25 mA for any one pin, V _{DD} = 4.75 to 5.25V. 100 mA maximum combined IOL for GPort0; GPort2_Bit3; GPort3; GPort5_Bit2, 3, 6, 7; GPort6. 100 mA maximum combined IOL for GPort1; GPort2_Bit0, 1, 2; GPort4; GPort5_Bit0, 1, 4, 5; GPort7. 200 mA maximum combined IOL.
V _{IL}	Input Low Level	–	–	0.8	V	V _{DD} = 3.0 to 5.5.
V _{IH}	Input High Level	2.1	–	–	V	V _{DD} = 3.0 to 5.5.
I _{IL}	Input Leakage (Absolute Value)	–	1	–	nA	Gross tested to 1 μA.
C _{IN}	Capacitive Load on Pins as Input	–	3.5	10	pF	Package and pin dependent. Temp = 25°C.
C _{OUT}	Capacitive Load on Pins as Output	–	3.5	10	pF	Package and pin dependent. Temp = 25°C.

4.4 AC Electrical Characteristics

4.4.1 AC General Purpose I/O Specifications

The following table lists guaranteed maximum and minimum specifications for the voltage and temperature ranges: 4.75V to 5.25V and $-40^{\circ}\text{C} \leq T_A \leq 85^{\circ}\text{C}$, or 3.0V to 3.6V and $-40^{\circ}\text{C} \leq T_A \leq 85^{\circ}\text{C}$, respectively. Typical parameters apply to 5V and 3.3V at 25°C and are for design guidance only or unless otherwise specified.

Table 4-9: AC GPIO Specifications

Symbol	Description	Min	Typ	Max	Units	Notes
F_{GPIO}	GPIO Operating Frequency	0	–	12	MHz	Normal Strong Mode
T_{RiseF}	Rise Time, Normal Strong Mode, Cload = 50 pF	3	–	18	ns	Vdd = 4.75 to 5.25V, 10% - 90%
T_{FallF}	Fall Time, Normal Strong Mode, Cload = 50 pF	2	–	18	ns	Vdd = 4.75 to 5.25V, 10% - 90%
T_{RiseS}	Rise Time, Slow Strong Mode, Cload = 50 pF	10	27	–	ns	Vdd = 3 to 5.25V, 10% - 90%
T_{FallS}	Fall Time, Slow Strong Mode, Cload = 50 pF	10	22	–	ns	Vdd = 3 to 5.25V, 10% - 90%

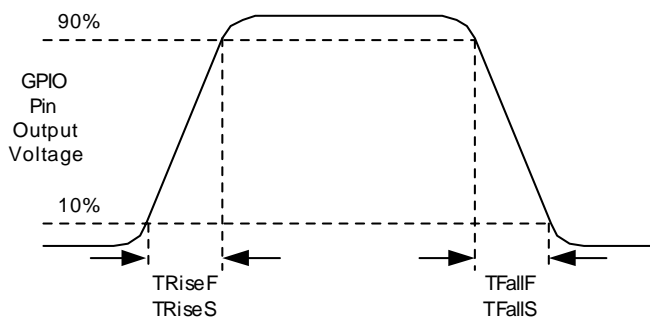

Figure 4-1. GPIO Timing Diagram

4.4.2 AC PWM Output Jitter Specifications

The following table lists guaranteed maximum and minimum specifications for the voltage and temperature ranges: 4.75V to 5.25V and $-40^{\circ}\text{C} \leq T_A \leq 85^{\circ}\text{C}$, or 3.0V to 3.6V and $-40^{\circ}\text{C} \leq T_A \leq 85^{\circ}\text{C}$, respectively. Typical parameters apply to 5V and 3.3V at 25°C and are for design guidance only or unless otherwise specified.

Table 4-10: AC PWM Output Jitter Specifications

Symbol	Description	Min	Typ	Max	Units	Notes
Jitter24MHzPWM	24 MHz-Based PWM Peak-to-Peak Period Jitter	–	0.1	1.5	%	24 MHz, 1.5 MHz, 93.75kHz and 367.6 Hz (programmable) sources.
Jitter32kHzPWM	32 kHz-Based PWM Peak-to-Peak Period Jitter	–	2.5	5.0	%	32 kHz clock source.

4.4.3 AC I²C Specifications

The following table lists guaranteed maximum and minimum specifications for the voltage and temperature ranges: 4.75V to 5.25V and $-40^{\circ}\text{C} \leq T_A \leq 85^{\circ}\text{C}$, or 3.0V to 3.6V and $-40^{\circ}\text{C} \leq T_A \leq 85^{\circ}\text{C}$, respectively. Typical parameters apply to 5V and 3.3V at 25°C and are for design guidance only or unless otherwise specified.

Table 4-11: AC Characteristics of the I²C SDA and SCL Pins

Symbol	Description	Standard Mode		Fast Mode		Units	Notes
		Min	Max	Min	Max		
F _{SCL I2C}	SCL Clock Frequency	0	100	0	400	kHz	
T _{HDSTAI2C}	Hold Time (repeated) START Condition. After this period, the first clock pulse is generated.	4.0	–	0.6	–	μs	
T _{LOWI2C}	LOW Period of the SCL Clock	4.7	–	1.3	–	μs	
T _{HIGHI2C}	HIGH Period of the SCL Clock	4.0	–	0.6	–	μs	
T _{SUSTA I2C}	Set-up Time for a Repeated START Condition	4.7	–	0.6	–	μs	
T _{HDDATI2C}	Data Hold Time	0	–	0	–	μs	
T _{SUDATI2C}	Data Set-up Time	250	–	100 ³	–	ns	
T _{SUSTOI2C}	Set-up Time for STOP Condition	4.0	–	0.6	–	μs	
T _{BUFI2C}	Bus Free Time Between a STOP and START Condition	4.7	–	1.3	–	μs	
T _{SPI2C}	Pulse Width of spikes are suppressed by the input filter.	–	–	0	50	ns	

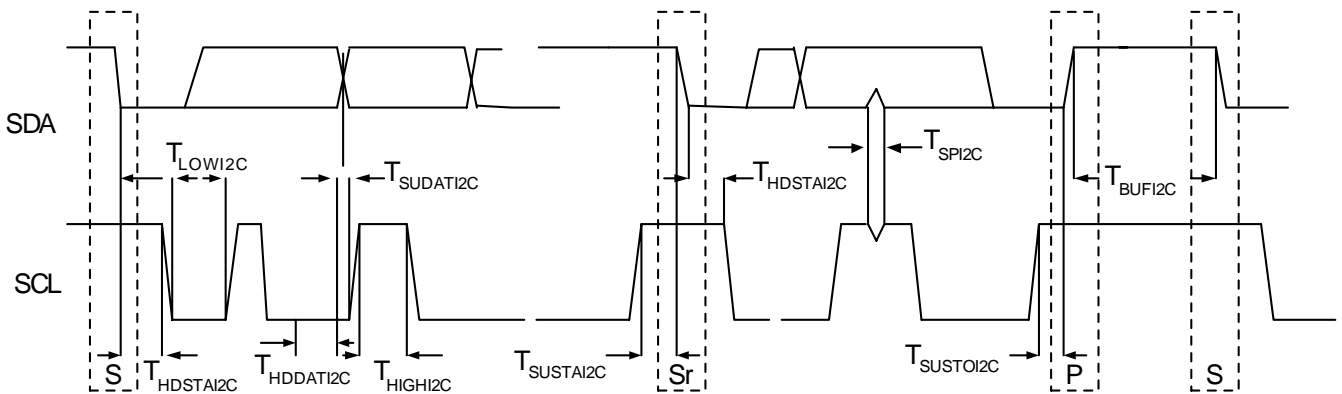

Figure 4-2. Definition for Timing for Fast/Standard Mode on the I²C Bus

5. Packaging Information



This chapter illustrates the packaging specifications for the CY8C95xx device, along with the thermal impedances for each package, the typical package capacitance on crystal pins, and the solder reflow peak temperature.

Important Note Emulation tools may require a larger area on the target PCB than the chip's footprint. For a detailed description of the emulation tools' dimensions, refer to the document titled *PSoC Emulator Pod Dimensions* at <http://www.cypress.com/support/link.cfm?mr=poddim>.

5.1 Packaging Dimensions

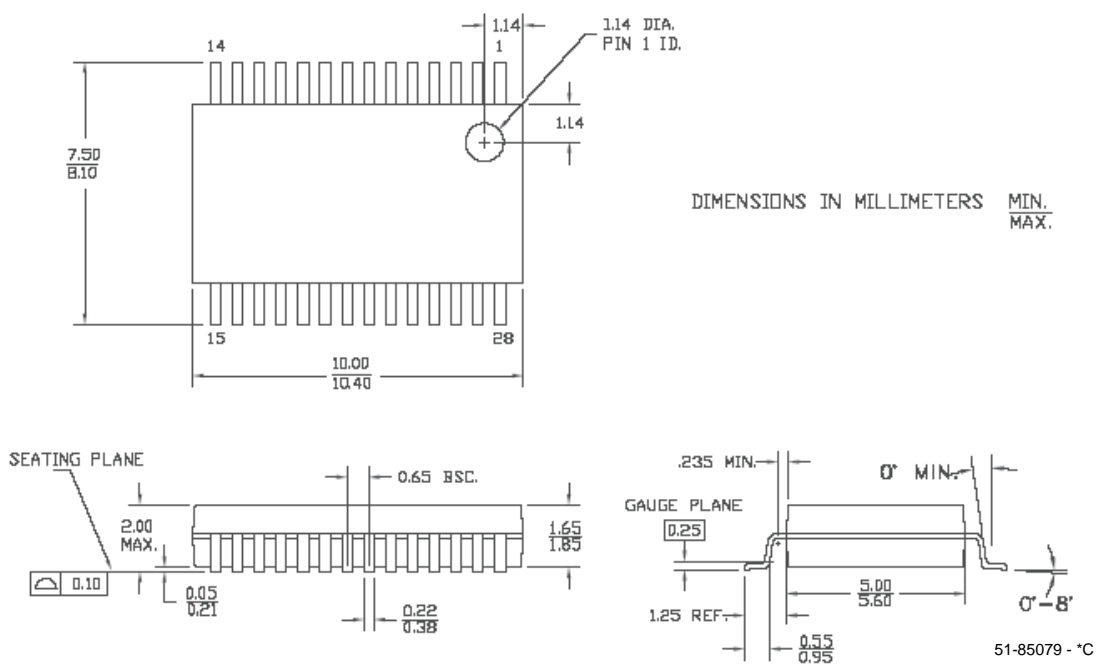

Figure 5-1. 28-Lead (210-Mil) SSOP

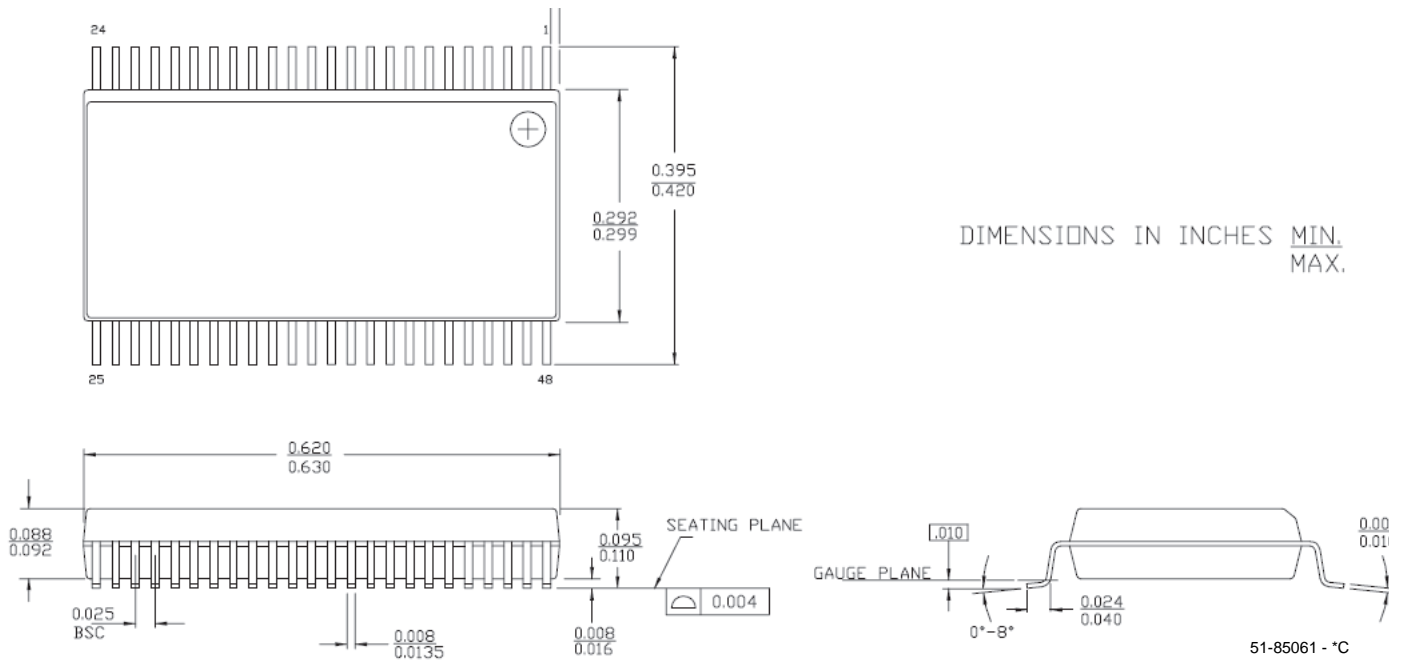

Figure 5-2. 48-Lead (300-Mil) SSOP

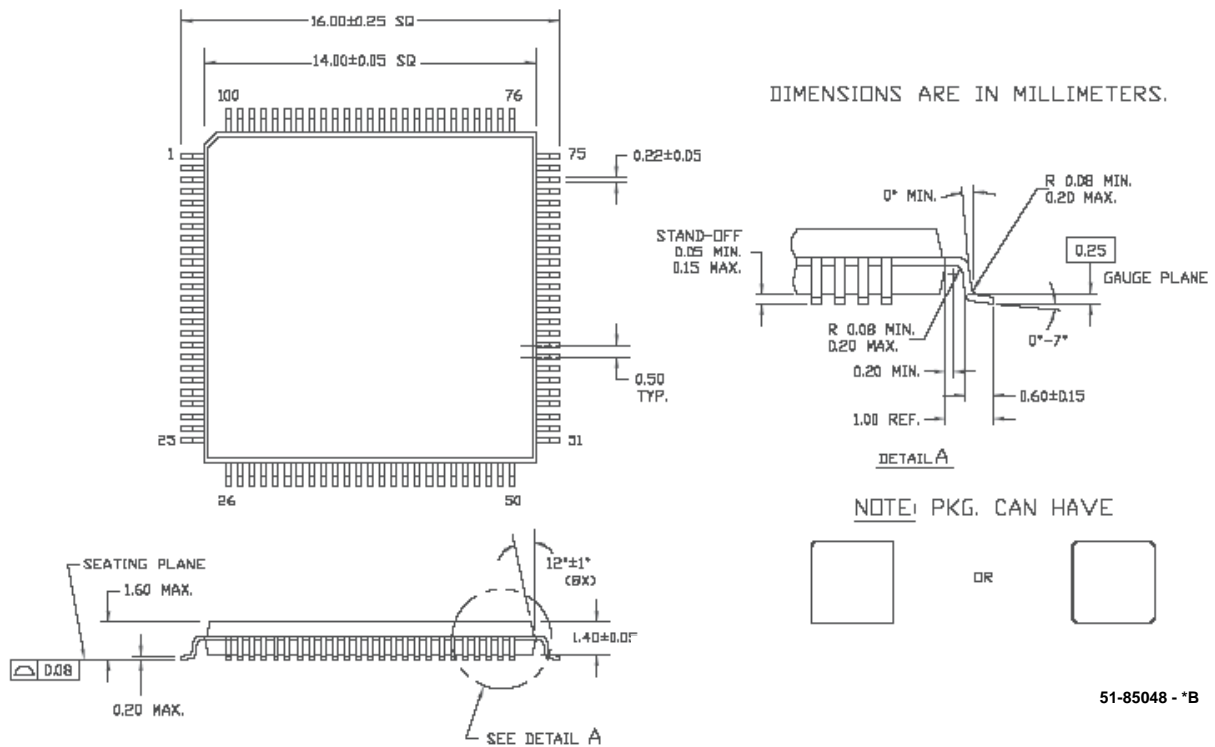

Figure 5-3. 100-Lead (14 x 14 x 1.0 mm) TQFP

5.2 Thermal Impedances

Table 5-1. Thermal Impedances per Package

Package	Typical θ_{JA} *
28 SSOP	101°C/W
48 SSOP	69°C/W
100 TQFP	48°C/W

$$* T_J = T_A + \text{POWER} \times \theta_{JA}$$

5.3 Solder Reflow Peak Temperature

Following is the minimum solder reflow peak temperature to achieve good solderability.

Table 5-2. Solder Reflow Peak Temperature

Package	Minimum Peak Temperature*	Maximum Peak Temperature
28 SSOP	240°C	260°C
48 SSOP	220°C	260°C
100 TQFP	220°C	260°C

*Higher temperatures may be required based on the solder melting point. Typical temperatures for solder are 220+/-5°C with Sn-Pb or 245+/-5°C with Sn-Ag-Cu paste. Refer to the solder manufacturer specifications.

6. Ordering Information



The following table lists the CY8C95xx device's key package features and ordering codes. A definition of the ordering number code is presented below.

Table 6-1. CY8C95xx Device Key Features and Ordering Information

Package	Ordering Code	EEPROM (Bytes)	Temperature Range	PWM Sources	Configurable I/O Pins
28 Pin (210 Mil) SSOP	CY8C9520-24PVXI	3K	-40C to +85C	4	20
28 Pin (210 Mil) SSOP (Tape and Reel)	CY8C9520-24PVXIT	3K	-40C to +85C	4	20
48 Pin (300 Mil) SSOP	CY8C9540-24PVXI	11K	-40C to +85C	8	40
48 Pin (300 Mil) SSOP (Tape and Reel)	CY8C9540-24PVXIT	11K	-40C to +85C	8	40
100 Pin TQFP	CY8C9560-24AXI	27K	-40C to +85C	16	60
100 Pin TQFP (Tape and Reel)	CY8C9560-24AXIT	27K	-40C to +85C	16	60

6.1 Ordering Code Definitions

CY 8 C 9 xxx-SPxx

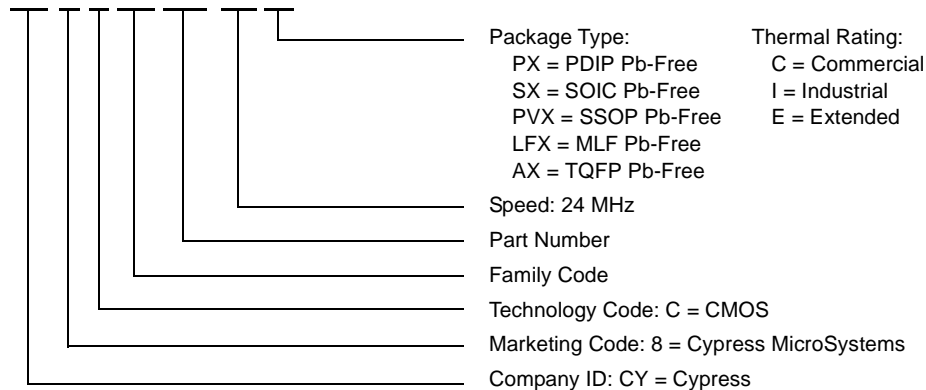

7. Sales and Service Information



To obtain information about Cypress Semiconductor or sales and technical support, reference the following information.

Cypress Semiconductor

2700 162nd Street SW, Building D
Lynnwood, WA 98087

Phone: 800.669.0557

Facsimile: 425.787.4641

Web Sites: Company Information – <http://www.cypress.com>
Sales – http://www.cypress.com/aboutus/sales_locations.cfm
Technical Support – <http://www.cypress.com/support/login.cfm>

7.1 Revision History

Table 7-1. CY8C95xx Data Sheet Revision History

Document Title: CY8C95xx Preliminary Data Sheet				
Document Number: 38-12036				
Revision	ECN #	Issue Date	Origin of Change	Description of Change
**	346754	See ECN	HMT	New silicon, document.
*A	392484	See ECN	HMT	Correct pin 79 on the TQFP. Add AC PWM Output Jitter spec. table. Upgrade to CY Perform logo and update zip code and trademarks.
Distribution: External/Public		Posting: None		

7.2 Copyrights and Code Protection

Copyrights

© Cypress Semiconductor Corp. 2005. All rights reserved. PSoC™, PSoC Designer™, Programmable System-on-Chip™, and PSoC Express™ are trademarks of Cypress Semiconductor Corp. All other trademarks or registered trademarks referenced herein are property of the respective corporations.

The information contained herein is subject to change without notice. Cypress Semiconductor assumes no responsibility for the use of any circuitry other than circuitry embodied in a Cypress Semiconductor product. Nor does it convey or imply any license under patent or other rights. Cypress Semiconductor does not authorize its products for use as critical components in life-support systems where a malfunction or failure may reasonably be expected to result in significant injury to the user. The inclusion of Cypress Semiconductor products in life-support systems application implies that the manufacturer assumes all risk of such use and in doing so indemnifies Cypress Semiconductor against all charges. Cypress Semiconductor products are not warranted nor intended to be used for medical, life-support, life-saving, critical control or safety applications, unless pursuant to an express written agreement with Cypress Semiconductor.

Flash Code Protection

Note the following details of the Flash code protection features on Cypress Semiconductor PSoC-related devices.

Cypress MicroSystems products meet the specifications contained in their particular Cypress Semiconductor Data Sheets. Cypress Semiconductor believes that its family of products is one of the most secure families of its kind on the market today, regardless of how they are used. There may be methods, unknown to Cypress Semiconductor, that can breach the code protection features. Any of these methods, to our knowledge, would be dishonest and possibly illegal. Neither Cypress Semiconductor nor any other semiconductor manufacturer can guarantee the security of their code. Code protection does not mean that we are guaranteeing the product as "unbreakable."

Cypress Semiconductor is willing to work with the customer who is concerned about the integrity of their code. Code protection is constantly evolving. We at Cypress Semiconductor are committed to continuously improving the code protection features of our products.