

PLEASE CHECK WWW.MOLEX.COM FOR LATEST PART INFORMATION

Part Number: [0878320843](#)
Status: **Active**
Overview: milligrid
Description: 2.00mm (.079") Pitch Milli-Grid™ Header, Surface Mount, Vertical, Shrouded, 8 Circuits, 0.76µm (30µ") Gold (Au) Plating, with Locking Window, Pick-and-Place Cap, PCB Locator, Tube, Lead-free

Documents:

[Drawing \(PDF\)](#) [RoHS Certificate of Compliance \(PDF\)](#)
[Product Specification PS-87831-027 \(PDF\)](#)

Agency Certification

CSA LR19980
 UL E29179

General

Product Family PCB Headers
 Series [87832](#)
 Application Wire-to-Board
 Comments With Cap|Contact Molex for application in automotive industry
 Overview [milligrid](#)
 Product Name Milli-Grid™

Physical

Breakaway No
 Circuits (Loaded) 8
 Circuits (maximum) 8
 Color - Resin Black
 First Mate / Last Break No
 Flammability 94V-0
 Glow-Wire Compliant No
 Guide to Mating Part No
 Keying to Mating Part Yes
 Lock to Mating Part Yes
 Material - Metal Phosphor Bronze
 Material - Plating Mating Gold
 Material - Plating Termination Tin
 Material - Resin Nylon
 Number of Rows 2
 Orientation Vertical
 PCB Locator Yes
 PCB Retention None
 Packaging Type Tube
 Pitch - Mating Interface (in) 0.079 In
 Pitch - Mating Interface (mm) 2.00 mm
 Pitch - Term. Interface (in) 0.079 In
 Pitch - Term. Interface (mm) 2.00 mm
 Plating min: Mating (µin) 30
 Plating min: Mating (µm) 0.76
 Plating min: Termination (µin) 75
 Plating min: Termination (µm) 1.88
 Polarized to Mating Part Polarizing Ribs
 Polarized to PCB Yes
 Robotic Placement Pick and Place Cap
 Shrouded Fully

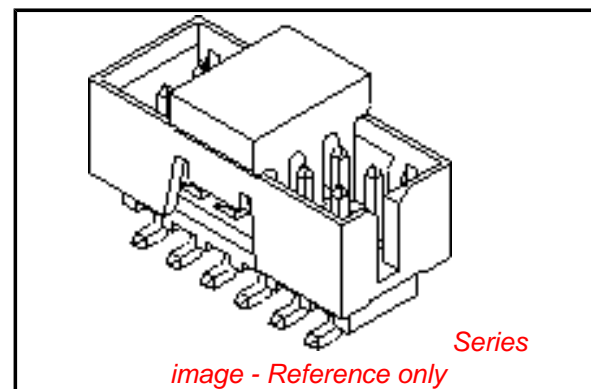

EU RoHS

ELV and RoHS Compliant
REACH SVHC Contains SVHC: No
Halogen-Free Status
Not Reviewed

China RoHS



Need more information on product environmental compliance?

Email productcompliance@molex.com
 For a multiple part number RoHS Certificate of Compliance, [click here](#)

Please visit the [Contact Us](#) section for any non-product compliance questions.

Search Parts in this Series

[87832Series](#)

Mates With

[50394](#) Wire-to-Board Terminals. [51110](#) Wire-to-Board Crimp Housing. [87568](#) Wire-to-Board IDT Housings. [79107](#) Board-to-Board Top Entry Through Hole Receptacle. [79108](#) Board-to-Board FFC/FPC Top Entry Through Hole Receptacle. [79109](#) Board

Stackable	No
Temperature Range - Operating	-55°C to +105°C
Termination Interface: Style	Surface Mount

Electrical

Current - Maximum per Contact	2A
Voltage - Maximum	125V

Material Info**Reference - Drawing Numbers**

Product Specification	PS-87831-027
Sales Drawing	SD-87832-013

This document was generated on 05/25/2010

PLEASE CHECK WWW.MOLEX.COM FOR LATEST PART INFORMATION

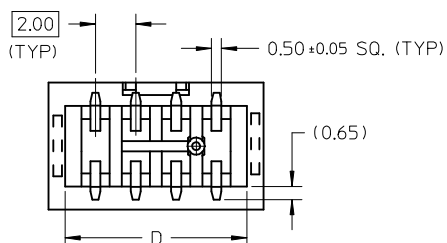
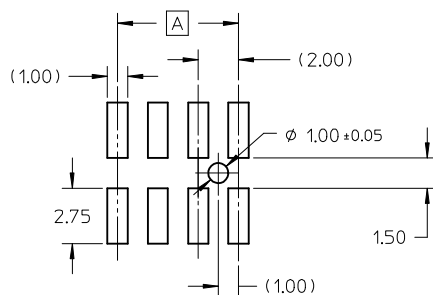
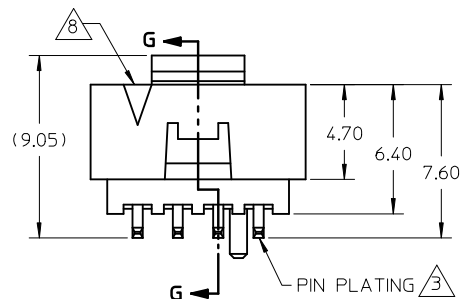
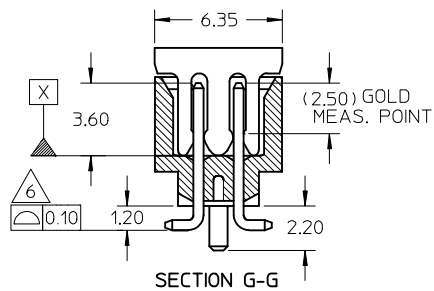
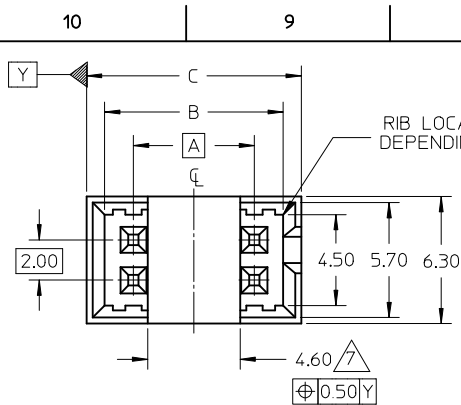

PEG OPTION	P/N WITH CAP IN TAPE & REEL		P/N WITH CAP IN TUBE		CKT SIZE	DIMENSION			
	15µm Gold	30µm Gold	15µm Gold	30µm Gold		A	B	C	D
NO	87832-0440	87832-0442	87832-0441	87832-0443	4	2.00	4.85	6.65	5.00
YES	87832-0640	87832-0642	87832-0641	87832-0643	6	4.00	6.85	8.65	7.00
YES	87832-0840	87832-0842	87832-0841	87832-0843	8	6.00	8.85	10.65	9.00
YES	87832-1040	87832-1042	87832-1041	87832-1043	10	8.00	10.85	12.65	11.00
YES	87832-1240	87832-1242	87832-1241	87832-1243	12	10.00	12.85	14.65	13.00

NOTES:

- FOR ILLUSTRATION PURPOSES, 8 CIRCUIT SIZE WAFER IS SHOWN.
- MATERIAL :
HOUSING & CAP : 30% G.F., NYLON 46, UL94V-0, COLOR BLACK.
PIN : 0.50MM SQ.PHOSPHOR BRONZE.
- PLATING :
40, 41 - 0.38µm/15uin GOLD IN CONTACT AREA AND 1.88µm/75uin MIN.TIN IN SOLDER TAIL AREA OVER 1.27µm/50uin MIN. NICKEL OVERALL.
42, 43 - 0.76µm/30uin GOLD IN CONTACT AREA AND 1.88µm/75uin MIN.TIN IN SOLDER TAIL AREA OVER 1.27µm/50uin MIN. NICKEL OVERALL.
- PIN PUSHOUT FORCE : 0.91 KG MIN. IN EITHER DIRECTION.
- PRODUCT SPECIFICATION PS-87831-027 APPLIES.
- COPLANARITY IS TO BE MEASURED BY RESTING THE SOLDER TAIL ON A GAUGE SURFACE.
- CAP TO BE POSITION IN THE CENTER OF HEADER FOR PICK AND PLACE.
- CKT 4 & 6 HAS NO IDENTIFICATION TAG.
- THIS HEADER MATES WITH MOLEX:
 - CRIMP RECEPTACLE HOUSING, 51110 SERIES WITH CRIMP TERMINAL, 50394 SERIES.
 - 2MM MILLIGRID DUAL ROW IDT, 87568 SERIES.
- PARTS SHALL BE PACKED IN MOISTURE BAG WITH DESICCANT GEL.
- NO CENTRE POLARIZATION SLOT FOR CKT SIZE 4 AND 6.

4 CKT:
BOTH SIDE WITH POLARIZATION SLOT
6 CKT & ABV:
ONLY 1 SIDE WITH POLARIZATION SLOT

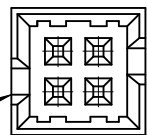

4 CKT TOP VIEW

REVISED EC NO: S2009-0943 DRWN:YMCHEONG CHKD:SKANG APPR:MLONG	DESCRIPTION 2009/07/01 2009/07/08 2009/07/16	QUALITY SYMBOLS	GENERAL TOLERANCES (UNLESS SPECIFIED)		DIMENSION STYLE		SCALE	DESIGN UNITS	THIRD ANGLE PROJECTION	
		▽=0 ∇=0	mm	INCH	MM ONLY		NTS	METRIC		
A5	REV		4 PLACES	± ---	± ---	DRAWN BY	DATE	TITLE		
			3 PLACES	± ---	± ---	ATSEE	2004/07/29	MGRID, SHROUDED HEADER W/PEG/CAP/LOCK FEATURES SMT, IN TUBE AND T&R		
			2 PLACES	± 0.15	± ---	CHECKED BY	DATE	MOLEX INCORPORATED		
			1 PLACE	± ---	± ---	KCLING	2004/08/05	MOLEX INCORPORATED		
			ANGULAR ± 3 °		APPROVED BY	DATE	DOCUMENT NO.		SHEET NO.	
			DRAFT WHERE APPLICABLE MUST REMAIN WITHIN DIMENSIONS		SKTOH	2004/08/05	SD-87832-013		1 OF 2	
					MATERIAL NO.	SEE TABLE		THIS DRAWING CONTAINS INFORMATION THAT IS PROPRIETARY TO MOLEX INCORPORATED AND SHOULD NOT BE USED WITHOUT WRITTEN PERMISSION		

WITH CAP IN TUBE PACKAGING

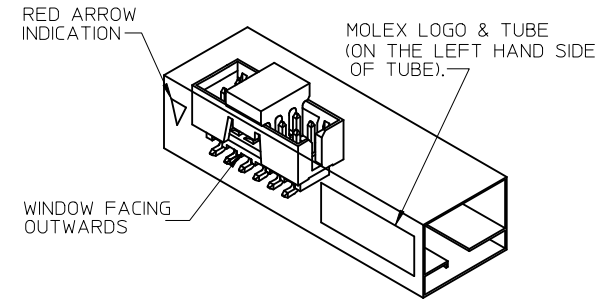
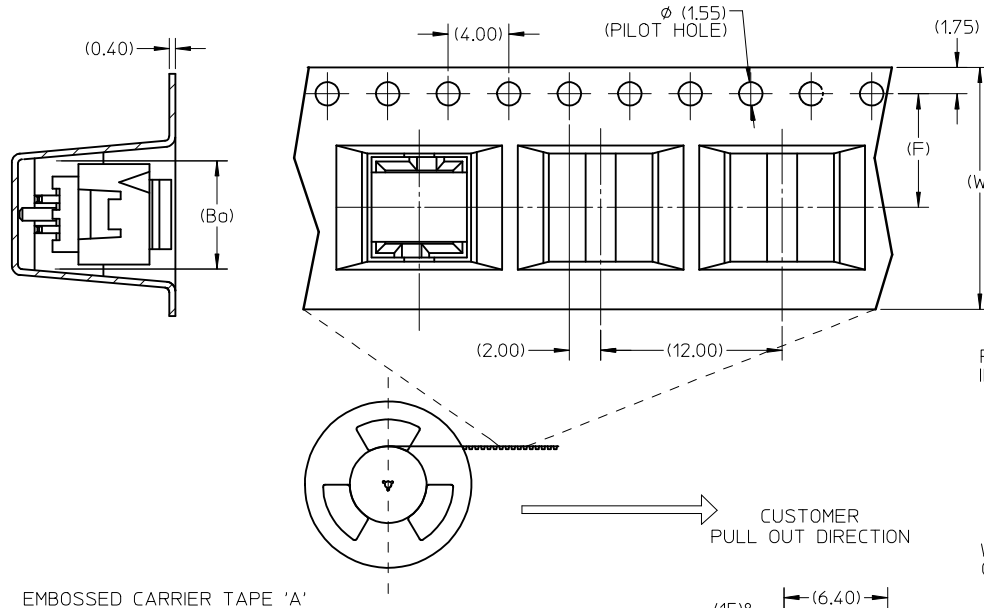
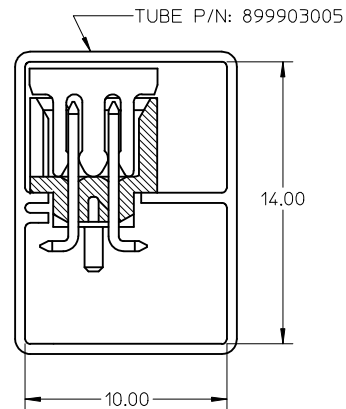
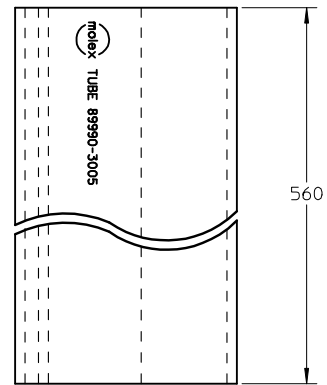

REF : ORIENTATION OF PART IN TUBE.
(FOR THE REFERENCE OF PART/TUBE ASSEMBLY.)

NOTES:

1. LEADER AND TRAILER TAPE

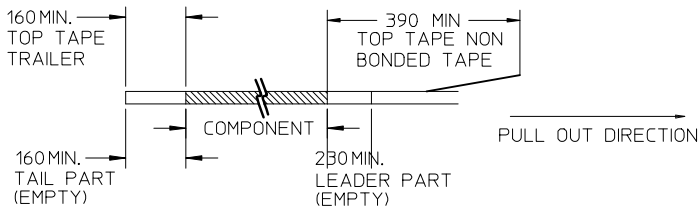

2. PEELING OFF FORCE OF THE TOP TAPE: 20-80gf.
(PEELING DIRECTION AS SHOWN IN FOLLOWING FIGURE)



3. PACKAGING STANDARD IS AS PER EIA-481.

PART NUMBER WITH CAP IN TAPE/REEL		CKT SIZE	EMBOSS TAPE PART NUMBER	TOP TAPE NUMBER	REEL NUMBER	(F)	(Bo)	(So)	(W)
87832-0440	87832-0442	4	89990-7601	89990-5602	89990-5709	7.50	7.15	-	16.00
87832-0640	87832-0642	6	89990-7752	89990-5603	89990-5710	11.50	9.15	-	24.00
87832-0840	87832-0842	8	89990-7753	89990-5603	89990-5710	11.50	11.05	-	24.00
87832-1040	87832-1042	10	89990-7754	89990-5603	89990-5710	11.50	13.05	-	24.00
87832-1240	87832-1242	12	89990-7755	89990-5604	89990-5711	14.20	15.15	28.40	32.00

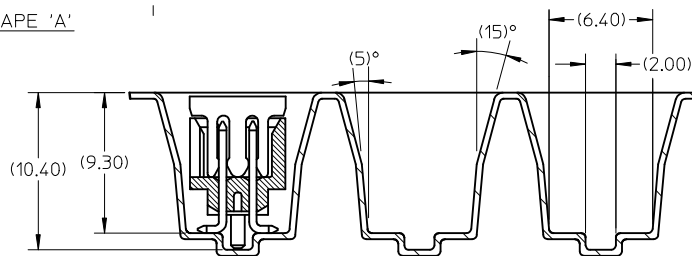

EMBOSSED CARRIER TAPE 'A'

REVISED	EC NO: S2009-0943	DRWN: YMC HONG	CHKD: SKANG	APPR: M LONG	DESCRIPTION	QUALITY SYMBOLS		GENERAL TOLERANCES (UNLESS SPECIFIED)		DIMENSION STYLE		SCALE	DESIGN UNITS	THIRD ANGLE PROJECTION	
						mm	INCH	MM ONLY	NTS	METRIC	DATE	DATE	DATE	DATE	
	2009/07/01	2009/07/08	2009/07/16			▽=0	∇=0	4 PLACES	± ---	± ---	DRAWN BY	DATE	TITLE	MGRID, SHROUDED HEADER W/PEG/CAP/LOCK FEATURES SMT, IN TUBE AND T&R MOLEX INCORPORATED	
								3 PLACES	± ---	± ---	ATSEE	2004/07/29			
								2 PLACES	± 0.15	± ---	CHECKED BY	DATE			
								1 PLACE	± ---	± ---	KCL ING	2004/08/05			
								ANGULAR ± 3 °			APPROVED BY	DATE			
								DRAFT WHERE APPLICABLE MUST REMAIN WITHIN DIMENSIONS			SKTOH	2004/08/05			
											MATERIAL NO.	DOCUMENT NO.		SHEET NO.	
											SEE TABLE			2 OF 2	
											THIS DRAWING CONTAINS INFORMATION THAT IS PROPRIETARY TO MOLEX INCORPORATED AND SHOULD NOT BE USED WITHOUT WRITTEN PERMISSION				