

TENTATIVE TOSHIBA BIPOLAR LINEAR INTEGRATED CIRCUIT SILICON MONOLITHIC

TA8899AF**FM DEMODULATION IC FOR BROADCASTING SATELLITE RECEIVER**

TA8899AF combines the necessary function on a single monolithic integrated circuit to demodulate FM signal of the 2nd IF of DBS.

FEATURES

- 5V single power source
- 2nd IF AGC amplifier (AGC range 50dB or more)
- Logarithmic-linear type signal level amplifier
- PLL type FM detector (variable impedance built in)
- Adjustment free AFT circuit (IF frequency direct count type digital AFT) and also designed for keyed AFT system
- Output terminal of 1'st AGC control circuit

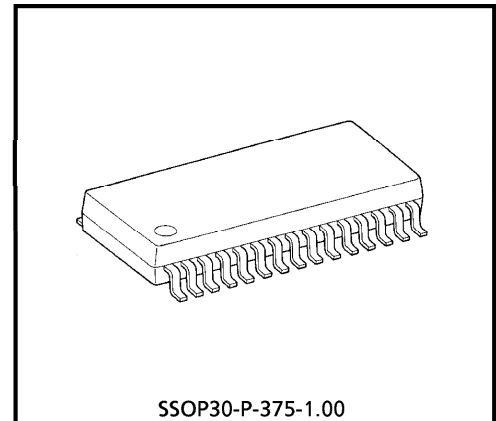

SSOP30-P-375-1.00
Weight : 0.63g (Typ.)

000707EBA1

- TOSHIBA is continually working to improve the quality and reliability of its products. Nevertheless, semiconductor devices in general can malfunction or fail due to their inherent electrical sensitivity and vulnerability to physical stress. It is the responsibility of the buyer, when utilizing TOSHIBA products, to comply with the standards of safety in making a safe design for the entire system, and to avoid situations in which a malfunction or failure of such TOSHIBA products could cause loss of human life, bodily injury or damage to property. In developing your designs, please ensure that TOSHIBA products are used within specified operating ranges as set forth in the most recent TOSHIBA products specifications. Also, please keep in mind the precautions and conditions set forth in the "Handling Guide for Semiconductor Devices," or "TOSHIBA Semiconductor Reliability Handbook" etc..
- The TOSHIBA products listed in this document are intended for usage in general electronics applications (computer, personal equipment, office equipment, measuring equipment, industrial robotics, domestic appliances, etc.). These TOSHIBA products are neither intended nor warranted for usage in equipment that requires extraordinarily high quality and/or reliability or a malfunction or failure of which may cause loss of human life or bodily injury ("Unintended Usage"). Unintended Usage include atomic energy control instruments, airplane or spaceship instruments, transportation instruments, traffic signal instruments, combustion control instruments, medical instruments, all types of safety devices, etc.. Unintended Usage of TOSHIBA products listed in this document shall be made at the customer's own risk.
- The products described in this document are subject to the foreign exchange and foreign trade laws.
- The information contained herein is presented only as a guide for the applications of our products. No responsibility is assumed by TOSHIBA CORPORATION for any infringements of intellectual property or other rights of the third parties which may result from its use. No license is granted by implication or otherwise under any intellectual property or other rights of TOSHIBA CORPORATION or others.
- The information contained herein is subject to change without notice.

BLOCK DIAGRAM

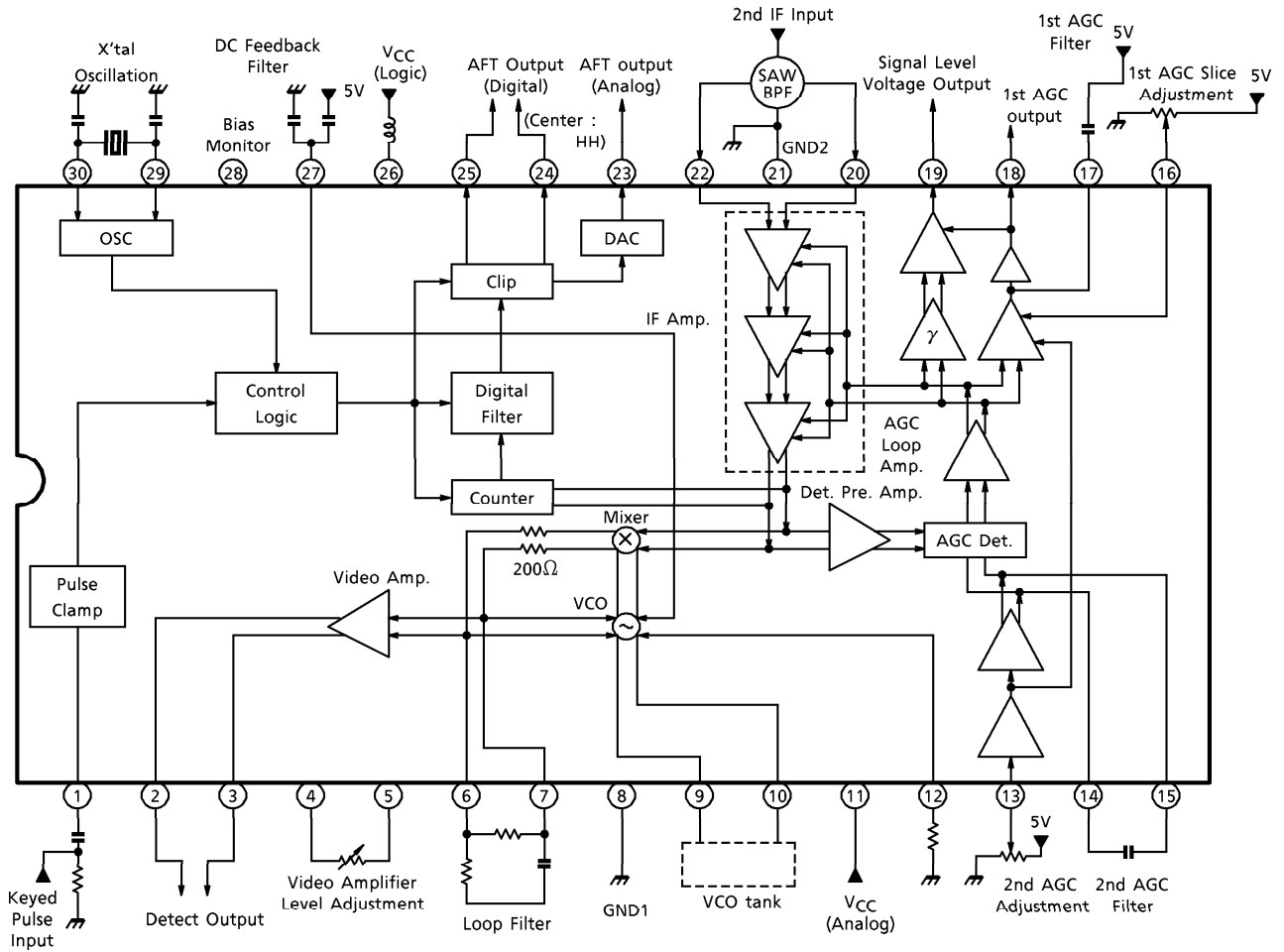

TERMINAL FUNCTION

| PIN No. | PIN NAME | FUNCTION | INTERFACE CIRCUIT |
|---------|----------------------------------|--|-------------------|
| 1 | Keyed Pulse Input | It clamps at the pulse peak and generates the reference level. The input impedance is $3k\Omega$. | |
| 2 3 | Detect Output | It outputs the detection output through a low-pass filter of 30MHz cut off frequency using an emitter follower. | |
| 4 5 | Video Amplifier Level Adjustment | It controls the level adjustment by varying the emitter resistor of a differential amplifier. If the resistor between pins 4 and 5 is reduced the output will be greater, however, since the output dynamic range is narrow the output level should be used in the range of lower than $0.7V_{p-p}$. | |
| 6 7 | Loop Filter | The output impedance is 200Ω . | |

| PIN No. | PIN NAME | FUNCTION | INTERFACE CIRCUIT |
|---------|---------------------------------|---|-------------------|
| 8 | GND1 | It is the GND of VCO circuit blocks that are VCO (pins 9, 10, 12), loop filter (pins 6, 7), video amplifier (pins 4, 5) AFT system (pins 1, 23, 24, 25, 26, 27, 28) and S/H (pins 29, 30). | — |
| 9 10 | VCO tank | It is the VCO using variations in internal impedance of diode for control voltage from mixer. Use a UJ characteristic for the capacitor of the external tank circuit to correct the internal temperature drift. | |
| 12 | VCO Temperature Compensate Bias | The VCO bias is composed of a synthesis of bias in proportion to V_{BE} and V_T of transistor, and this terminal generates a bias proportioned to the V_{BE} . If the external resistor is reduced, the VCO sensitivity will rise. | |
| 13 | 2nd AGC Adjustment | It changes the input level into AGC detector. It adjusts by adding the direct current offset to pins 14 and 15. The variation width of about 8dB can be added. Internal bias is 2.5V. | |

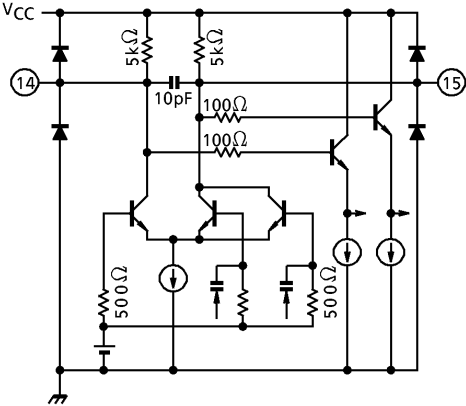
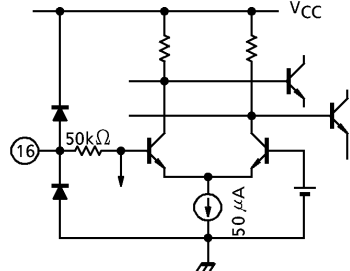
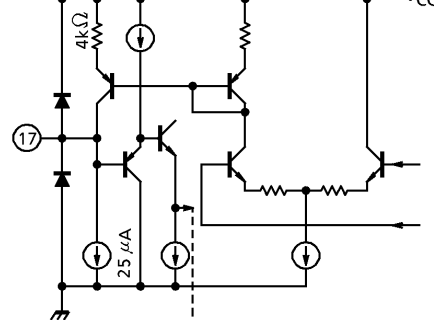
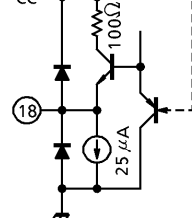
| PIN No. | PIN NAME | FUNCTION | INTERFACE CIRCUIT |
|----------|--------------------------|---|--|
| 14 15 | 2nd AGC Filter | It generates the AGC voltage by filtering the 403MHz IF signal by means of an internal resistor and an external capacitor. If applying the V _{CC} to pin 15 and with supplying 2.5V bias to pin 27, the AGC will be minimum gain and the VCO oscillates at free-running frequency. |  |
| 16 | 1st AGC Slice Adjustment | It sets the input level threshold for generating the control signal to lower gain from the IC to the 2nd converter of front stage when excessive signal input. Even if the 2nd AGC adjustment varies, the 1st AGC adjustment point hardly changes. The internal bias is 2.5V. |  |
| 17 | 1st AGC Filter | It outputs by comparing with the AGC and 1st AGC slice level adjustment voltages. This comparator is constructed by the active load type high gain amplifier and determined its response by a capacitor connected to this terminal. |  |
| 18 | 1st AGC Control | It outputs the control voltage using an emitter follower (active low level). The internal current sink has only 25μA. |  |

| PIN No. | PIN NAME | FUNCTION | INTERFACE CIRCUIT |
|----------|-----------------------------|--|-------------------|
| 19 | Signal Level Voltage Output | It outputs the AGC voltage by doing logarithm --> linear conversion. In the TA8899AF the level detection can be carried out even after the 1st AGC is effective and input is reduced using the 1st AGC output. | |
| 20 22 | 2nd IF Input | The IF amplifier constructed by the 3-step series connection of variable gm type amplifiers, of which the maximum gain is 47dB and minimum gain - 8dB. In order to prevent a sneak of radio frequency, all the circuits are balance-connected. Therefore, the differential combination is also desirable for the IC input. The internal bias is 2.0V and input impedance is 1kΩ. | |
| 23 | AFT Output (Analog) | This counts the IF frequency, averages the count data, carries out D/A conversion of the signal and outputs an AFT signal. X'tal is used for the reference signal of this AFT operation, so operation is stabilized against temperature. Furthermore, an AFT signal is created from an IF signal, and so VCO oscillation is an independent operation. | |

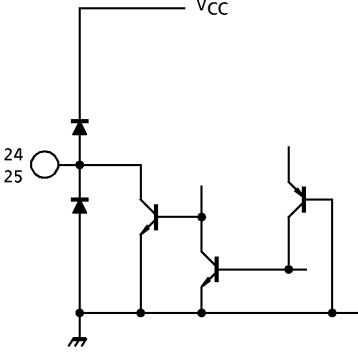
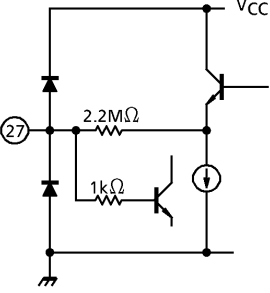
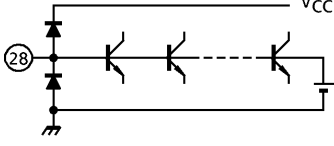
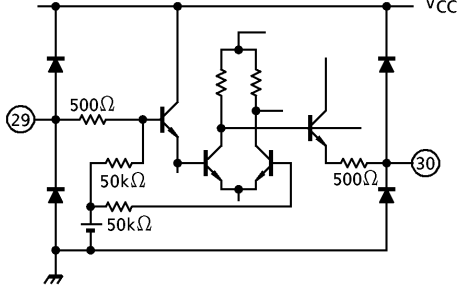
| PIN No. | PIN NAME | FUNCTION | INTERFACE CIRCUIT |
|----------|----------------------|--|--|
| 24 25 | AFT Output (Digital) | These are high detection ("H" when the IF signal is high) and low detection ("H" when the IF signal is low). These shows both outputs is high when the input frequency is nearby 402.78MHz. |  |
| 26 | VCC (Logic Block) | To avoid interference of digital circuits and analog circuits connect to the power line through a 1μH inductor. | — |
| 27 | DC Feedback Filter | In order to correct the lag between the VCO's fo and the input's IF signal, the wave detection output's DC offset is used and a circuit installed which feeds this back to the VCO oscillation frequency. The low pass filter for detecting this DC offset is composed of an internal resistor and an external capacitor. (fc ≐ 1Hz) |  |
| 28 | Bias Monitor | This terminal monitors the bias of an internal logic circuit. Normally keep it open. |  |
| 29 30 | X'tal Oscillation | This is the 4MHz X'tal oscillation terminal, the reference for internal digital operations. When supplying 4MHz OSC from other, please input to a 29 pin. |  |

MAXIMUM RATINGS (Ta = 25°C)

| CHARACTERISTIC | SYMBOL | RATING | UNIT |
|-----------------------|---------------------|------------|------|
| Power Supply Voltage | V _{CC} MAX | 6.0 | V |
| Power Dissipation | P _D MAX | 1000 | mW |
| Operation Temperature | T _{opr} | - 20~75 | °C |
| Storage Temperature | T _{stg} | - 55~150 | °C |
| Lead Temperature | — | 260°C, 10s | |

Recommended assembly method : Recommended temperature profile of reflow soldering of far and medium infrared rays

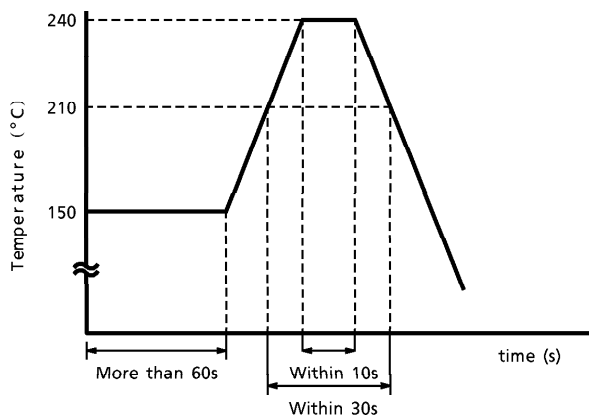

RECOMMENDED POWER SUPPLY VOLTAGE

| PIN No. | PIN NAME | MIN. | TYP. | MAX. | UNIT |
|---------|--------------------------|------|------|------|------|
| 11 | V _{CC} (Analog) | 4.75 | 5.0 | 5.25 | V |
| 26 | V _{CC} (Logic) | 4.75 | 5.0 | 5.25 | V |

ELECTRICAL CHARACTERISTICS

DC CHARACTERISTICS (Unless otherwise specified, $V_{CC} = 5.0V$, $T_a = 25^\circ C$)

| CHARACTERISTIC | SYMBOL | TEST CIR-CUIT | TEST CONDITION | MIN. | TYP. | MAX. | UNIT | |
|------------------------------------|------------|---------------|----------------|---------------------------|------|------|------|------|
| Supply Current | I_{CC} | 1 | — | 75 | 100 | 125 | mA | |
| Terminal Voltage | Pin 1 | V_1 | — | 2.0 | 2.5 | 3.0 | V | |
| | Pin 2 | V_2 | — | 1.5 | 2.0 | 2.5 | | |
| | Pin 3 | V_3 | — | 1.5 | 2.0 | 2.5 | | |
| | Pin 4 | V_4 | — | 0.8 | 1.3 | 1.8 | | |
| | Pin 5 | V_5 | — | 0.8 | 1.3 | 1.8 | | |
| | Pin 6 | V_6 | — | 2.2 | 2.7 | 3.2 | | |
| | Pin 7 | V_7 | — | 2.2 | 2.7 | 3.2 | | |
| | Pin 9 | V_9 | — | 2.2 | 2.7 | 3.2 | | |
| | Pin 10 | V_{10} | — | 2.2 | 2.7 | 3.2 | | |
| | Pin 12 | V_{12} | 1 | 1.8k Ω -GND | 0.08 | 0.2 | | 0.32 |
| | Pin 13 | V_{13} | 1 | — | 2.3 | 2.5 | | 2.7 |
| | Pin 14 | V_{14} | 1 | — | — | 3.7 | | — |
| | Pin 15 | V_{15} | 1 | — | — | 3.9 | | — |
| | Pin 16 | V_{16} | 1 | — | 2.1 | 2.5 | | 2.9 |
| | Pin 18 | V_{18h} | 1 | Pin 17 : 1k Ω -GND | — | 1.0 | | 1.3 |
| | | V_{18l} | 1 | Pin 17 : V_{CC} | 3.9 | 4.3 | | 4.7 |
| | Pin 20 | V_{20} | 1 | — | 1.5 | 2.0 | | 2.5 |
| | Pin 22 | V_{22} | 1 | — | 1.5 | 2.0 | | 2.5 |
| | Pin 28 | V_{28} | 1 | — | 1.8 | 2.2 | | 2.6 |
| | Pin 29 | V_{29} | 1 | — | 2.3 | 2.7 | | 3.0 |
| Pin 30 | V_{30} | 1 | — | 2.3 | 2.7 | 3.0 | | |
| Pin 2, 3 Acceptable Output Current | I_2, I_3 | 1 | — | -1.0 | — | 6.0 | mA | |
| 1st AGC Output Current | I_{18} | 1 | — | -0.02 | — | 6.0 | mA | |

AC CHARACTERISTICS

| CHARACTERISTIC | SYMBOL | TEST CIR-CUIT | TEST CONDITION | MIN. | TYP. | MAX. | UNIT |
|---|-----------------------|---------------|--|----------|-----------|-----------|-----------|
| IF Input Frequency Range | f_{in} | 2 | — | 350 | 400 | 550 | MHz |
| IF Input Level Range | v_{in} | 2 | — | - 50 | — | - 10 | dBmW |
| 1st AGC Shoulder Level Range | AGC _{MAX} | 2 | Pin 16 = 2.5V | - 33 | - 26 | - 19 | dBmW |
| 1st AGC Control Sensitivity | Δ AGC | 2 | — | 1.3 | 2.7 | — | V / dB |
| Signal Level Sensitivity | $\Delta V / \Delta v$ | 2 | — | 50 | 100 | 150 | mV / dB |
| VCO Conversion Sensitivity | β | 2 | — | 60 | 80 | 110 | MHz / V |
| VCO Temperature Drift | Δf_{Ta} | 2 | Ta = - 10~65°C | — | ± 1.0 | ± 2.5 | MHz |
| PLL Lock Range | f_L | 2 | — | ± 20 | ± 30 | — | MHz |
| PLL Capture Range | f_c | 2 | — | ± 20 | ± 30 | — | MHz |
| Demodulation Output Level | V_{out} | 2 | $\Delta f = 10\text{MHz}_{p-p}$ Converting to output rate Pin 4, 5 : 2.4k Ω | 0.35 | 0.50 | 0.65 | V_{p-p} |
| Video Amplifier Variable Width | v_o S/5 | 2 | Pin 4, 5 : short, 5k Ω | 10 | — | — | dB |
| Demodulation Output Amplitude Frequency Characteristics 1 | v_o A1 | 2 | f = 0.2~4MHz Reference : 100kHz | — | — | ± 2 | dB |
| Demodulation Output Amplitude Frequency Characteristics 2 | v_o A2 | 2 | f = 4~9MHz Reference : 100kHz | — | — | ± 2 | dB |
| Group Delay Characteristics 1 | τ_{pd1} | 2 | f = 0.2~4MHz Reference : 100kHz | — | — | ± 10 | ns |
| Group Delay Characteristics 2 | τ_{pd2} | 2 | f = 4~9MHz Reference : 100kHz | — | — | ± 40 | ns |
| Keyed AFT Input Range | v_1 | 2 | — | 0.35 | 0.5 | 0.65 | V_{p-p} |
| Keyed AFT Input Frequency | T_1 | 2 | — | 8.0 | 16.7 | 50 | ms |
| AFT Sensitivity | $\Delta f / \Delta V$ | 2 | — | 1.5 | 2.0 | 2.8 | MHz / V |
| AFT Width of Dead Zone | V_{DEAD} | 2 | — | 281 | 313 | 344 | kHz |
| Digital AFT Voltage Low Level | V_{20L} | 2 | — | — | 0.2 | 0.5 | V |
| D G | DG | 2 | APL : 10~90% | — | ± 2.0 | ± 3.0 | % |
| D P | DP | 2 | APL : 10~90% | — | ± 2.0 | ± 3.0 | ° |
| I M 2 | IM2 | 2 | 2.15MHz beat level (*) | 45 | 50 | — | dB |
| I M 3 | IM3 | 2 | 1.43MHz beat level (*) | 45 | 50 | — | dB |
| Video S/N | SN_{sat} | 2 | — | 51 | — | — | dB |
| External Input Level (4MHz Clock) | X_{in} | 2 | — | 0.3 | 0.5 | 0.7 | V_{p-p} |
| VCO Initial Drift | SWON | 2 | 3~20s | 0 | — | 850 | kHz |

(*) VCO coil must be adjusted to make IM2 / 3 best value

MEASUREMENT CONDITION

(Note 1) 1st AGC Shoulder Level Range : AGC_{MAX}

F = 402.78MHz input level $v_{in} = 0$ to -40 dBmW (50Ω) to pin 20. Measure v_{in} that pin 18 voltage is lower than 4V by opening pin 16 and raising v_{in} .

(Note 2) 1st AGC Control Sensitivity : ΔAGC

Input f = 402.78MHz $v_{in} = 0 \sim -40$ dBmW (50Ω) to pin 20. Calculate v_{in} that pin 18 voltage is 4V / 1V (as v_{in1} , v_{in2}), using the equation below.

$$\Delta AGC = -3 / (v_{in1} - v_{in2}) \quad V / dB$$

(Note 3) Signal Level Sensitivity : $\Delta V / \Delta v$

Measure each output voltage of pin 19 at $v_{in} = -40$, -60 dBmW (50Ω)

$$\Delta V / \Delta v = (V_{-60} - V_{-40}) / 20 \quad mV / dB$$

(Note 4) VCO Conversion Sensitivity : β

Input f = 402.78MHz and sweep ± 5 MHz, $v_{in} = -30$ dBmW (50Ω) to pin 20.

Calculate $\beta = 10 / (V_{det+5} - V_{det-5})$ and multiply the gain portion (2.66) of video amplifier when outputting a direct current voltage to pin 3 at 407.78MHz, 397.78MHz as V_{det+5} and V_{det-5} each.

(Note 5) VCO Temperature Drift : Δf_{Ta}

Short pin 6 and 7, and connect pin 14 to GND.

Measure the VCO frequency at ambient temperature $T_a = 25^\circ C$, $-10^\circ C$ + $65^\circ C$ and calculate how much frequency changes from at $25^\circ C$. (read out the VCO leakage output by spectrum analyzer.)

(Note 6) PLL Lock Range : f_L , Capture Range : f_{ca}

Measure the range that synchronizes with VCO by putting pin 20 input frequency away from the free-running frequency.

(Note 7) Demodulation Output Level : V_{out}

Input pin 20 f = 402.78MHz, $f_m = 100$ kHz, $\Delta f = 10$ MHz_{p-p}, $v_{in} = -30$ dBmW (50Ω)

Open pin 4 and 5 and measure the output level of pin 3.

(Note 8) Video Amplifier Variable Width : V_{outS} , V_{out5}

Input pin 20 f = 402.78MHz, $f_m = 100$ kHz, $\Delta f = 10$ MHz_{p-p}, $v_{in} = -30$ dBmW (50Ω)

Measure the variation of video output by shorting between pin 4 and 5 and connecting a $5k\Omega$ resistance.

(Note 9) Demodulation Output level Width, Group Delay Characteristics : V_{outA} , τ_{pd}

Input pin 20 f = 402.78MHz, $f_m = 100$ kHz, 60Hz to 4MHz to 9MHz, $\Delta f = 5$ MHz_{p-p}, $v_{in} = -30$ dBmW (50Ω)

Compare to the value at 100kHz by opening pin 4 and 5, and measuring the output level and group delay of pin 3.

(Note 10) Keyed Pulse Allowable Period : T_1

Input pin 20 $f = 402.78\text{MHz}$, $f_m = 100\text{kHz}$, $\Delta f = 10\text{MHz}_{\text{p-p}}$, $v_{\text{in}} = -30\text{dBmW}$ (50Ω)
 Input the signal below to pin 1 and open pin 27 and 28.

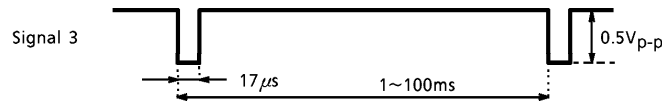

Observe the pin 23 output and change f so as to be 2.5V voltage.

(Note 11) AFT Sensitivity : $\Delta f / \Delta V_{23}$

Input pin 20 $f = 402.78\text{MHz} \pm 1\text{MHz}$, $v_{\text{in}} = -30\text{dBmW}$ (50Ω)

Adjust f so that pin 23 output will be 2.5V. By moving f up. and down, calculate each frequency as f_H , f_L when pin 23 voltage varies 0.5V using the following equation.

$$\Delta f / \Delta V_{23} = f_H - f_L \text{ (MHz/V)}$$

(Note 12) AFT Digital Output Width of dead zone : f_{DEAD}

Input pin 20 $f = 402.78\text{MHz} \pm 5\text{MHz}$, $v_{\text{in}} = -30\text{dBmW}$ (50Ω)

Measure the input frequency range in which both pin 24 and 25 become high level, by sweeping f .

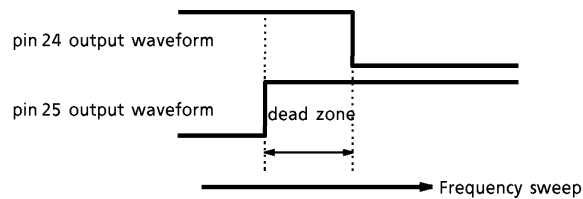

(Note 13) DG, DP

Input pin 20 $f = 402.78\text{MHz} \pm 5\text{MHz}$, $v_{\text{in}} = -30\text{dBmW}$ (50Ω), $\Delta f = 17\text{MHz}_{\text{p-p}}$, Gray level video signal (APL : 10~90%)...Pre-emphasis-on

(Note 14) IM2, IM3

Input pin 20 $f = 402.78\text{MHz} \pm 5\text{MHz}$, $v_{\text{in}} = -30\text{dBmW}$ (50Ω), $\Delta f = 17\text{MHz}_{\text{p-p}}$, Color subcarrier (3.579MHz), Sound subcarrier (5.7272MHz) ...

Observe the frequency component outputting to the screen output pin (pin 3) through the video gate of a video noise meter by spectrum analyzer, and measure the level difference between 3.579MHz component and 2.15MHz, 1.43MHz components.

TEST CIRCUIT 1
DC characteristics

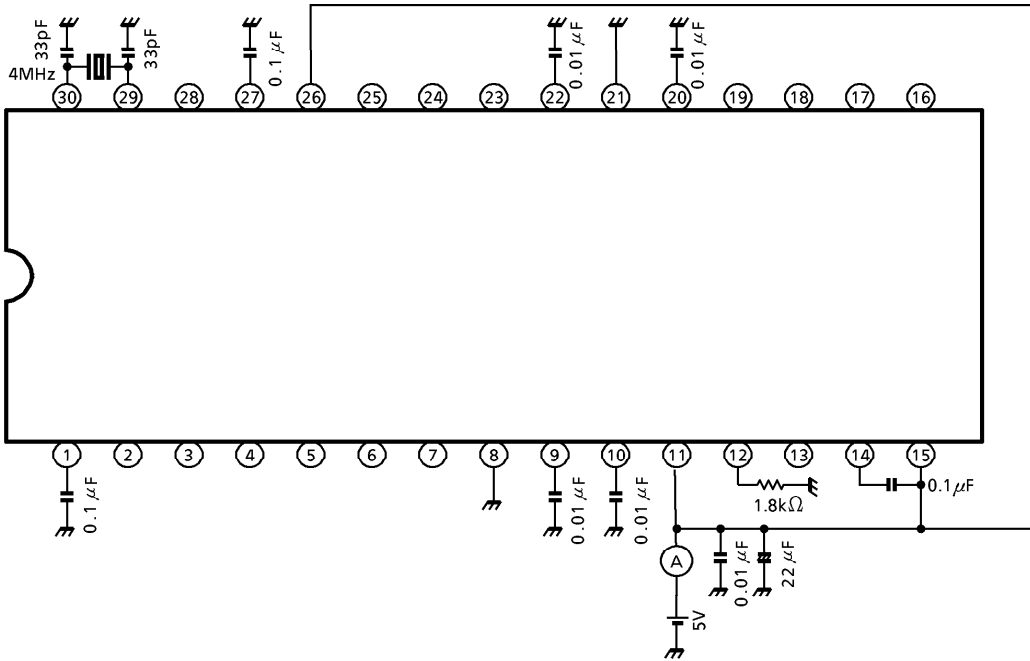

TEST CIRCUIT 2
AC characteristics

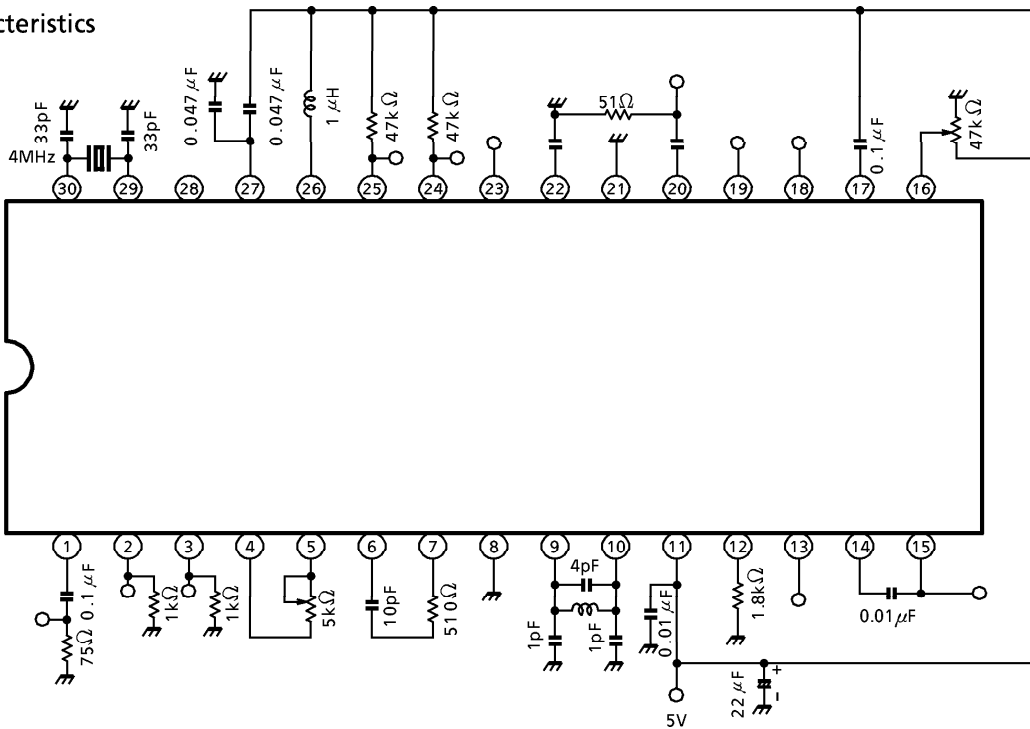

APPLICATION CIRCUIT
(402MHz IF)

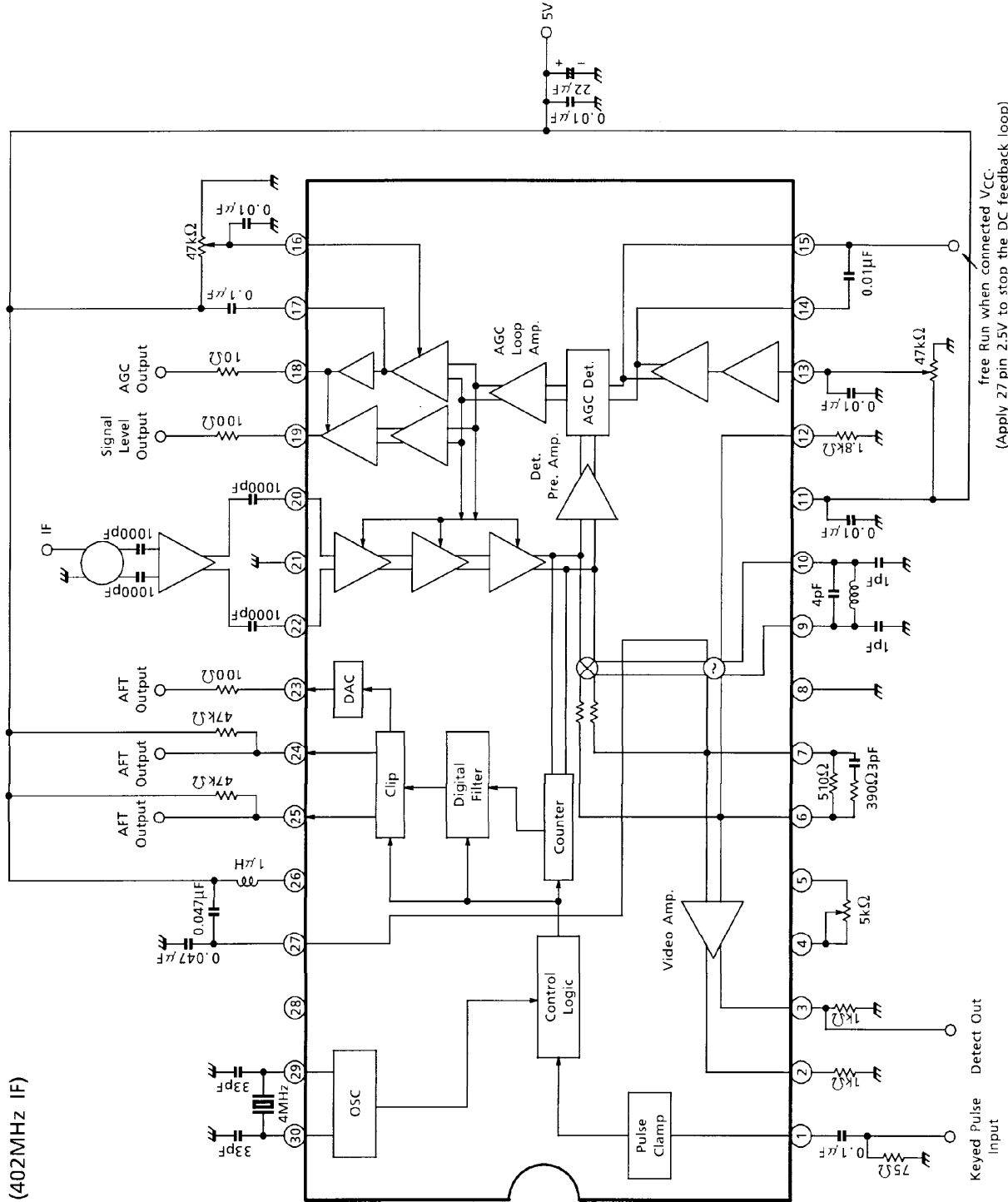

PACKAGE DIMENSIONS
SSOP30-P-375-1.00

Unit : mm

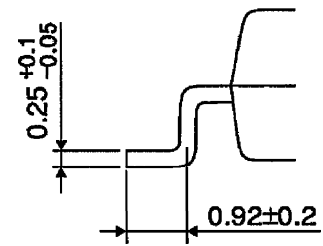
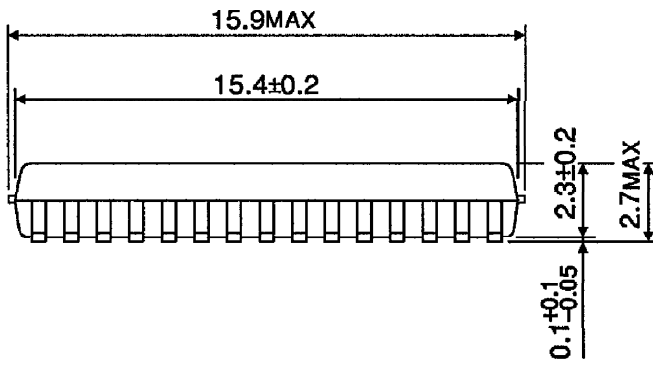
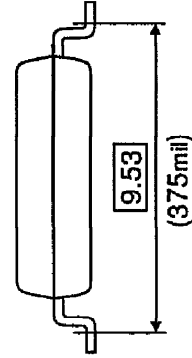
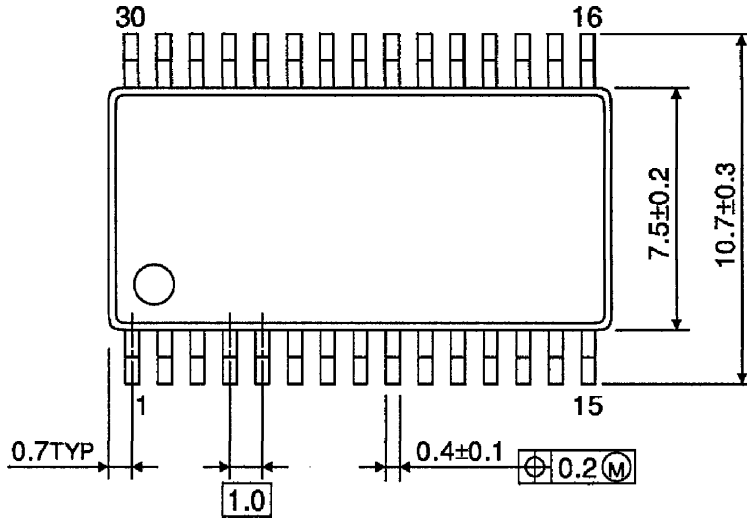

Weight : 0.63g (Typ.)