

# Customer Information Sheet

DRAWING No.: S1741-46R

SHEET 2 OF 2

IF IN DOUBT - ASK

©

NOT TO SCALE

THIRD ANGLE PROJECTION

ALL DIMENSIONS IN mm

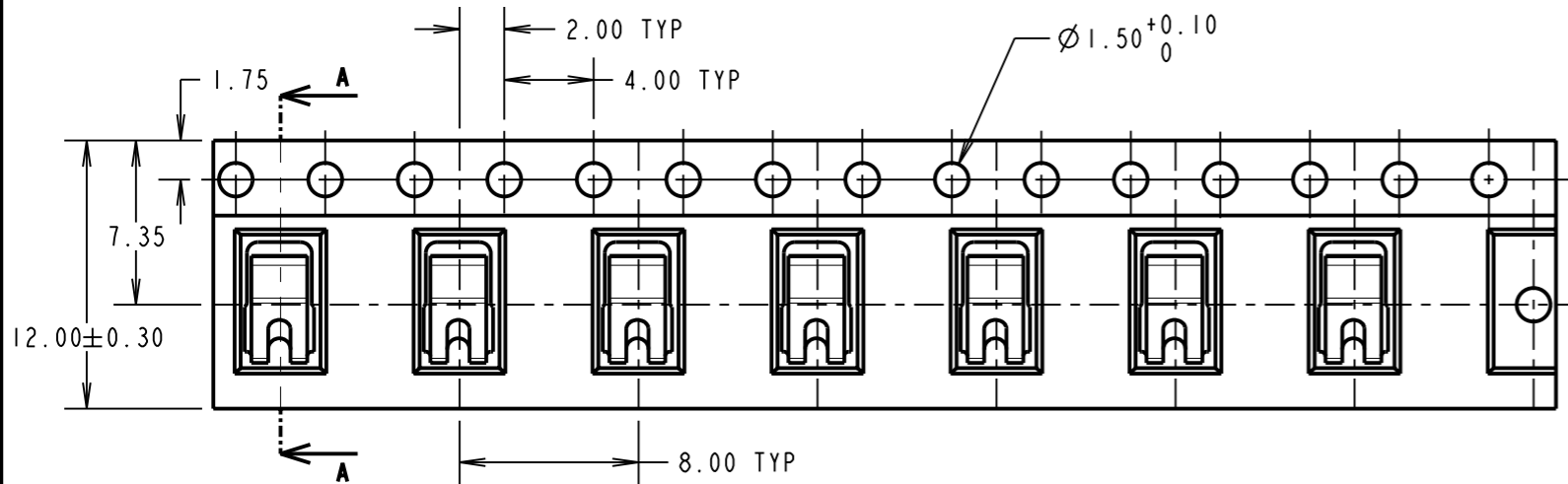

TAPE DIMENSIONS

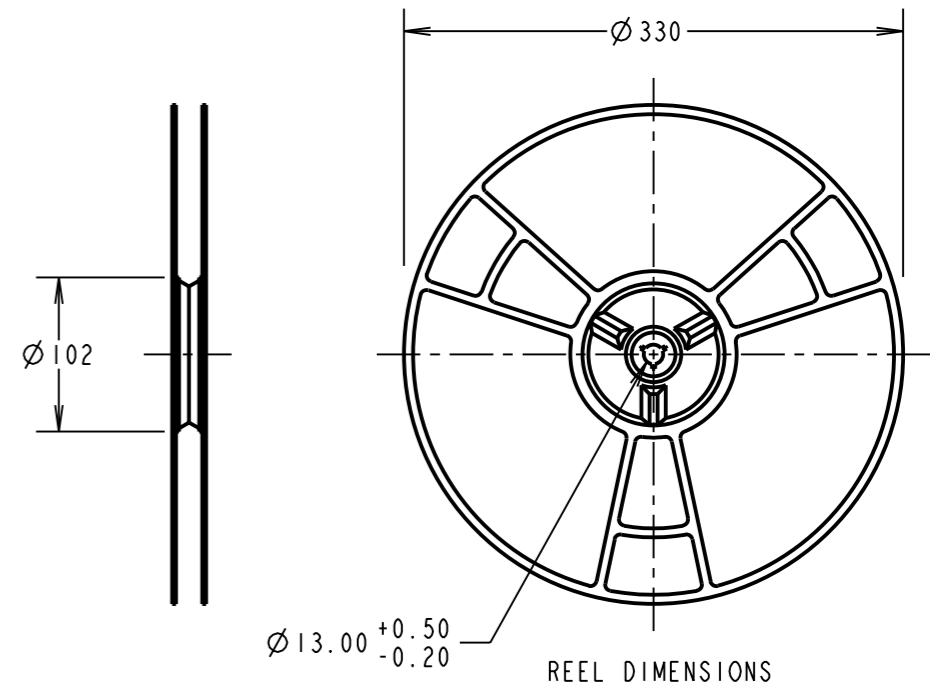
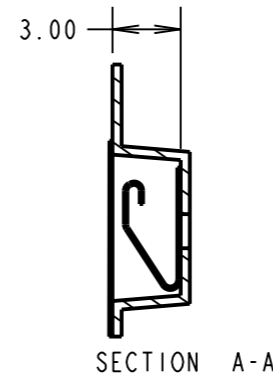

REEL DIMENSIONS

RECOMMENDED PAD LAYOUT

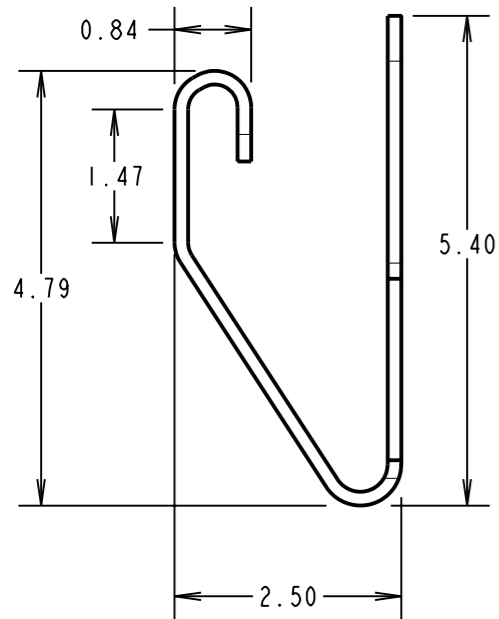

SINGLE COMPONENT DIMENSIONS

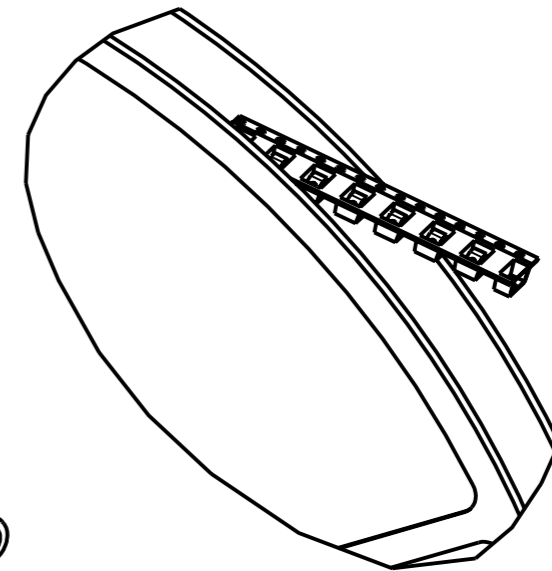
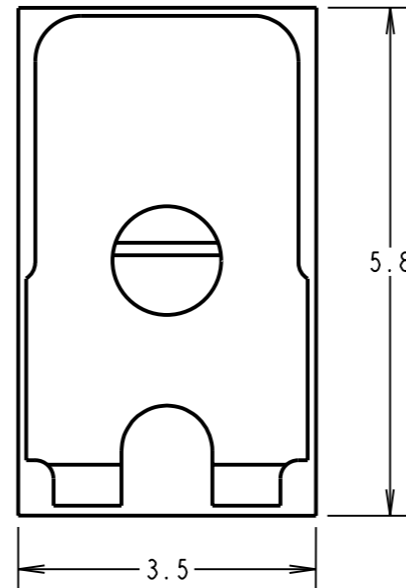
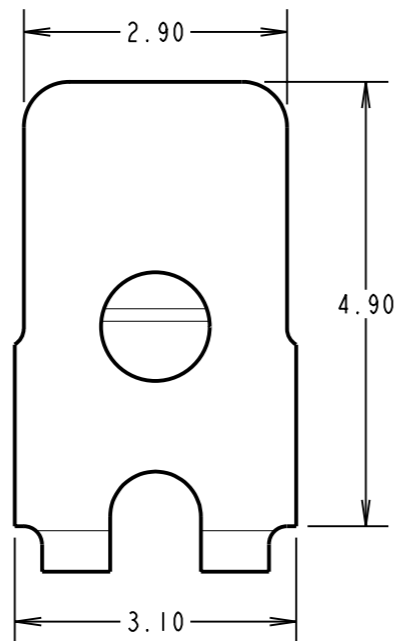

REELING DIRECTION

- NOTES:
1. QUANTITY PER REEL = 2500.
  2. THIS PRODUCT IS TAPED AND REELED IN ACCORDANCE WITH EIA-481-B (ELECTRONIC INDUSTRIES ASSOCIATION).

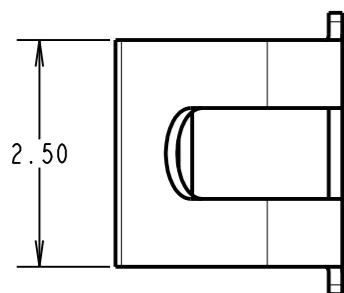

COMPONENT SPECIFICATION:  
 MATERIAL = PHOSPHOR BRONZE  
 FINISH = 4u BRIGHT 100% TIN OVER 2u NICKEL  
 RECOMMENDED WORKING HEIGHT = 1.75mm / MIN FORCE = 1.5N  
 MINIMUM WORKING HEIGHT = 150mm / MAX FORCE = 3.0N  
 MAXIMUM PERMANENT SET = 0.25mm

CP	B	03.03.10	10687
NAME	ISS.	DATE	C/NOTE
APPROVED: C.PENROSE			
CHECKED: R.ADDE			
DRAWN: N.CODLING			
CUSTOMER REF.:			
ASSEMBLY DRG:			

**HARWIN**

HARWIN USA TEL: 603 893 5376 FAX: 603 893 5396 mis@harwin.com	HARWIN Europe (UK) TEL: 023 9231 4545 FAX: 023 9231 4590 mis@harwin.co.uk	HARWIN Asia TEL: +65 6 779 4909 FAX: +65 6 779 3868 mis@harwin.com.sg
--	--	--

THIS DRAWING AND ANY INFORMATION OR DESCRIPTIVE MATTER SET OUT HEREON ARE CONFIDENTIAL AND COPYRIGHT PROPERTY OF THE HARWIN GROUP AND MUST NOT BE DISCLOSED, LOANED, COPIED OR USED FOR MANUFACTURING, TENDERING OR FOR ANY OTHER PURPOSE WITHOUT THEIR WRITTEN PERMISSION.

TOLERANCES  
 X. = ±1mm  
 X.X = ±0.25mm  
 X.XX = ±0.10mm  
 X.XXX = ±0.01mm  
 ANGLES = ±5°  
 UNLESS STATED

MATERIAL:  
 SEE ABOVE  
 FINISH:  
 S/AREA: mm<sup>2</sup>

TITLE:  
 S174-46 SURFACE MOUNT CONTACT  
 IN TAPE AND REEL  
 DRAWING NUMBER:  
**S1741-46R**  
 SHT  
 2 OF 2