

MC33030

DC Servo Motor Controller/Driver

The MC33030 is a monolithic DC servo motor controller providing all active functions necessary for a complete closed loop system. This device consists of an on-chip op amp and window comparator with wide input common-mode range, drive and brake logic with direction memory, Power H-Switch driver capable of 1.0 A, independently programmable over-current monitor and shutdown delay, and over-voltage monitor. This part is ideally suited for almost any servo positioning application that requires sensing of temperature, pressure, light, magnetic flux, or any other means that can be converted to a voltage.

Although this device is primarily intended for servo applications, it can be used as a switchmode motor controller.

- On-Chip Error Amp for Feedback Monitoring
- Window Detector with Deadband and Self Centering Reference Input
- Drive/Brake Logic with Direction Memory
- 1.0 A Power H-Switch
- Programmable Over-Current Detector
- Programmable Over-Current Shutdown Delay
- Over-Voltage Shutdown

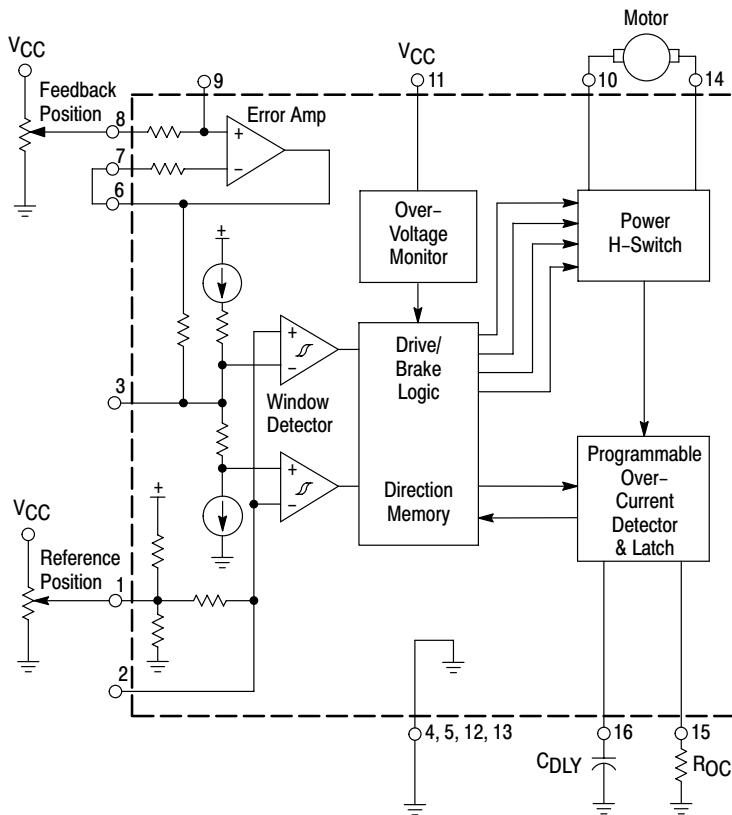

This device contains 119 active transistors.

Representative Block Diagram



ON Semiconductor™

<http://onsemi.com>

MARKING DIAGRAMS

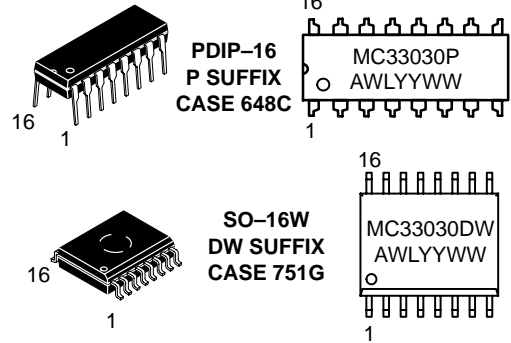

A = Assembly Location
 WL = Wafer Lot
 YY = Year
 WW = Work Week

PIN CONNECTIONS

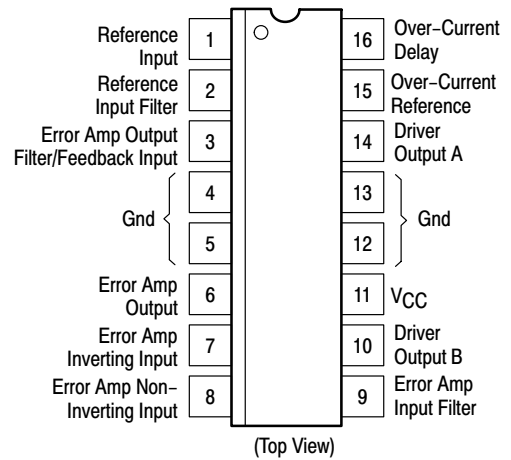

Pins 4, 5, 12 and 13 are electrical ground and heat sink pins for IC.

ORDERING INFORMATION

Device	Package	Shipping
MC33030DW	SO-16W	47 Units/Rail
MC33030DWR2	SO-16W	1000 Tape & Reel
MC33030P	PDIP-16	25 Units/Rail

MC33030

MAXIMUM RATINGS

Rating	Symbol	Value	Unit
Power Supply Voltage	V_{CC}	36	V
Input Voltage Range Op Amp, Comparator, Current Limit (Pins 1, 2, 3, 6, 7, 8, 9, 15)	V_{IR}	-0.3 to V_{CC}	V
Input Differential Voltage Range Op Amp, Comparator (Pins 1, 2, 3, 6, 7, 8, 9)	V_{IDR}	-0.3 to V_{CC}	V
Delay Pin Sink Current (Pin 16)	$I_{DLY(sink)}$	20	mA
Output Source Current (Op Amp)	I_{source}	10	mA
Drive Output Voltage Range (Note 1)	V_{DRV}	-0.3 to ($V_{CC} + V_F$)	V
Drive Output Source Current (Note 2)	$I_{DRV(source)}$	1.0	A
Drive Output Sink Current (Note 2)	$I_{DRV(sink)}$	1.0	A
Brake Diode Forward Current (Note 2)	I_F	1.0	A
Power Dissipation and Thermal Characteristics P Suffix, Dual In Line Case 648C Thermal Resistance, Junction-to-Air Thermal Resistance, Junction-to-Case (Pins 4, 5, 12, 13) DW Suffix, Dual In Line Case 751G Thermal Resistance, Junction-to-Air Thermal Resistance, Junction-to-Case (Pins 4, 5, 12, 13)	$R_{\theta JA}$ $R_{\theta JC}$ $R_{\theta JA}$ $R_{\theta JC}$	80 15 94 18	$^{\circ}C/W$
Operating Junction Temperature	T_J	+150	$^{\circ}C$
Operating Ambient Temperature Range	T_A	-40 to +85	$^{\circ}C$
Storage Temperature Range	T_{stg}	-65 to +150	$^{\circ}C$
Electrostatic Discharge Sensitivity (ESD) Human Body Model (HBM) Machine Model (MM)	ESD	2000 200	V

ELECTRICAL CHARACTERISTICS ($V_{CC} = 14\text{ V}$, $T_A = 25^{\circ}C$, unless otherwise noted.)

Characteristic	Symbol	Min	Typ	Max	Unit
ERROR AMP					
Input Offset Voltage ($-40^{\circ}C \leq T_A \leq 85^{\circ}C$) $V_{Pin\ 6} = 7.0\text{ V}$, $R_L = 100\text{ k}$	V_{IO}	-	1.5	10	mV
Input Offset Current ($V_{Pin\ 6} = 1.0\text{ V}$, $R_L = 100\text{ k}$)	I_{IO}	-	0.7	-	nA
Input Bias Current ($V_{Pin\ 6} = 7.0\text{ V}$, $R_L = 100\text{ k}$)	I_{IB}	-	7.0	-	nA
Input Common-Mode Voltage Range $\Delta V_{IO} = 20\text{ mV}$, $R_L = 100\text{ k}$	V_{ICR}	-	0 to ($V_{CC} - 1.2$)	-	V
Slew Rate, Open Loop ($V_{ID} = 0.5\text{ V}$, $C_L = 15\text{ pF}$)	SR	-	0.40	-	V/ μs
Unity-Gain Crossover Frequency	f_c	-	550	-	kHz
Unity-Gain Phase Margin	ϕ_m	-	63	-	deg.
Common-Mode Rejection Ratio ($V_{Pin\ 6} = 7.0\text{ V}$, $R_L = 100\text{ k}$)	CMRR	50	82	-	dB
Power Supply Rejection Ratio $V_{CC} = 9.0$ to 16 V , $V_{Pin\ 6} = 7.0\text{ V}$, $R_L = 100\text{ k}$	PSRR	-	89	-	dB
Output Source Current ($V_{Pin\ 6} = 12\text{ V}$)	I_{O+}	-	1.8	-	mA
Output Sink Current ($V_{Pin\ 6} = 1.0\text{ V}$)	I_{O-}	-	250	-	μA
Output Voltage Swing ($R_L = 17\text{ k}$ to Ground)	V_{OH} V_{OL}	12.5 -	13.1 0.02	- -	V V

- The upper voltage level is clamped by the forward drop, V_F , of the brake diode.
- These values are for continuous DC current. Maximum package power dissipation limits must be observed.

MC33030

ELECTRICAL CHARACTERISTICS (continued) ($V_{CC} = 14\text{ V}$, $T_A = 25^\circ\text{C}$, unless otherwise noted.)

Characteristic	Symbol	Min	Typ	Max	Unit
WINDOW DETECTOR					
Input Hysteresis Voltage ($V_1 - V_4$, $V_2 - V_3$, Figure 18)	V_H	25	35	45	mV
Input Dead Zone Range ($V_2 - V_4$, Figure 18)	V_{IDZ}	166	210	254	mV
Input Offset Voltage ($ [V_2 - V_{Pin\ 2}] - [V_{Pin\ 2} - V_4] $ Figure 18)	V_{IO}	–	25	–	mV
Input Functional Common-Mode Range (Note 3)					V
Upper Threshold	V_{IH}	–	$(V_{CC} - 1.05)$	–	
Lower Threshold	V_{IL}	–	0.24	–	
Reference Input Self Centering Voltage Pins 1 and 2 Open	V_{RSC}	–	$(1/2 V_{CC})$	–	V
Window Detector Propagation Delay Comparator Input, Pin 3, to Drive Outputs $V_{ID} = 0.5\text{ V}$, $R_L(DRV) = 390\ \Omega$	$t_p(IN/DRV)$	–	2.0	–	μs

OVER-CURRENT MONITOR

Over-Current Reference Resistor Voltage (Pin 15)	R_{OC}	3.9	4.3	4.7	V
Delay Pin Source Current $V_{DLY} = 0\text{ V}$, $R_{OC} = 27\text{ k}$, $I_{DRV} = 0\text{ mA}$	$I_{DLY}(\text{source})$	–	5.5	6.9	μA
Delay Pin Sink Current ($R_{OC} = 27\text{ k}$, $I_{DRV} = 0\text{ mA}$)	$I_{DLY}(\text{sink})$				mA
$V_{DLY} = 5.0\text{ V}$		–	0.1	–	
$V_{DLY} = 8.3\text{ V}$		–	0.7	–	
$V_{DLY} = 14\text{ V}$		–	16.5	–	
Delay Pin Voltage, Low State ($I_{DLY} = 0\text{ mA}$)	$V_{OL}(DLY)$	–	0.3	0.4	V
Over-Current Shutdown Threshold	$V_{th}(OC)$				V
$V_{CC} = 14\text{ V}$		6.8	7.5	8.2	
$V_{CC} = 8.0\text{ V}$		5.5	6.0	6.5	
Over-Current Shutdown Propagation Delay Delay Capacitor Input, Pin 16, to Drive Outputs, $V_{ID} = 0.5\text{ V}$	$t_p(DLY/DRV)$	–	1.8	–	μs

POWER H-SWITCH

Drive-Output Saturation ($-40^\circ\text{C} \leq T_A \leq +85^\circ\text{C}$, Note 4)					V
High-State ($I_{\text{source}} = 100\text{ mA}$)	$V_{OH}(DRV)$	$(V_{CC} - 2)$	$(V_{CC} - 0.85)$	–	
Low-State ($I_{\text{sink}} = 100\text{ mA}$)	$V_{OL}(DRV)$	–	0.12	1.0	
Drive-Output Voltage Switching Time ($C_L = 15\text{ pF}$)					ns
Rise Time	t_r	–	200	–	
Fall Time	t_f	–	200	–	
Brake Diode Forward Voltage Drop ($I_F = 200\text{ mA}$, Note 4)	V_F	–	1.04	2.5	V

TOTAL DEVICE

Standby Supply Current	I_{CC}	–	14	25	mA
Over-Voltage Shutdown Threshold ($-40^\circ\text{C} \leq T_A \leq +85^\circ\text{C}$)	$V_{th}(OV)$	16.5	18	20.5	V
Over-Voltage Shutdown Hysteresis (Device “off” to “on”)	$V_H(OV)$	0.3	0.6	1.0	V
Operating Voltage Lower Threshold ($-40^\circ\text{C} \leq T_A \leq +85^\circ\text{C}$)	V_{CC}	–	7.5	8.0	V

3. The upper or lower hysteresis will be lost when operating the Input, Pin 3, close to the respective rail. Refer to Figure 4.

4. Low duty cycle pulse techniques are used during test to maintain junction temperature as close to ambient temperature as possible.

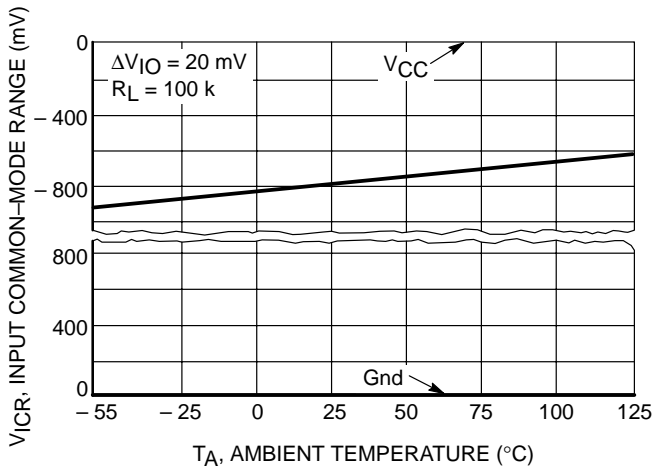

Figure 1. Error Amp Input Common-Mode Voltage Range versus Temperature

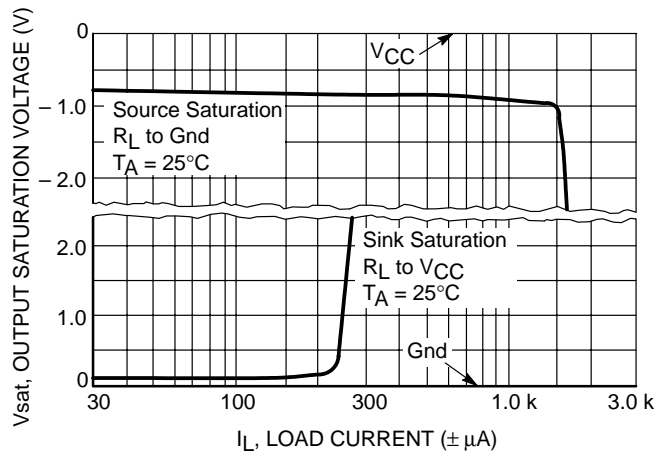

Figure 2. Error Amp Output Saturation versus Load Current

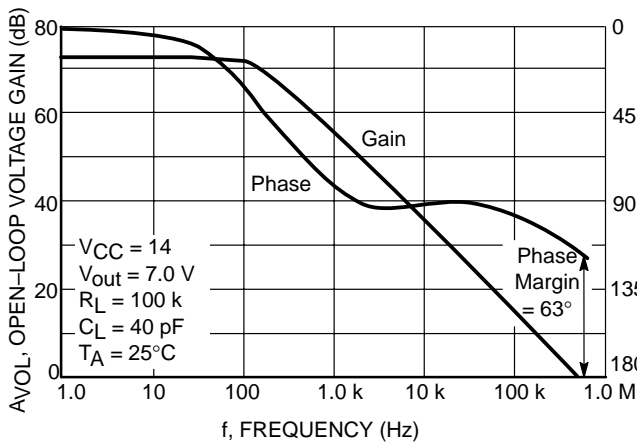

Figure 3. Open Loop Voltage Gain and Phase versus Frequency

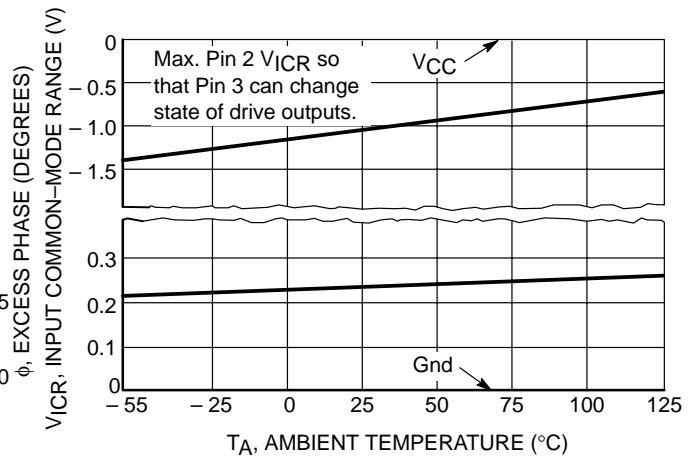

Figure 4. Window Detector Reference-Input Common-Mode Voltage Range versus Temperature

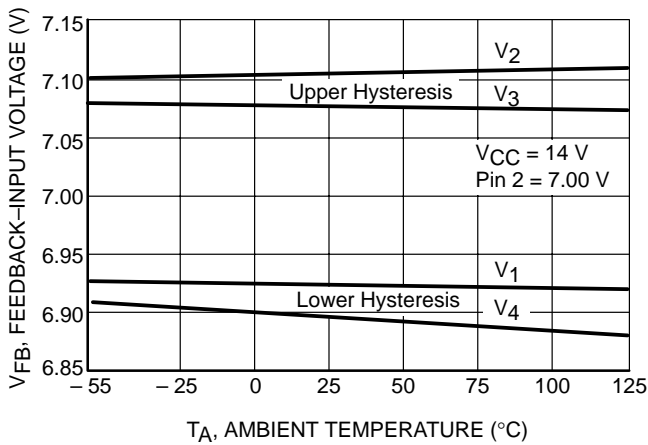

Figure 5. Window Detector Feedback-Input Thresholds versus Temperature

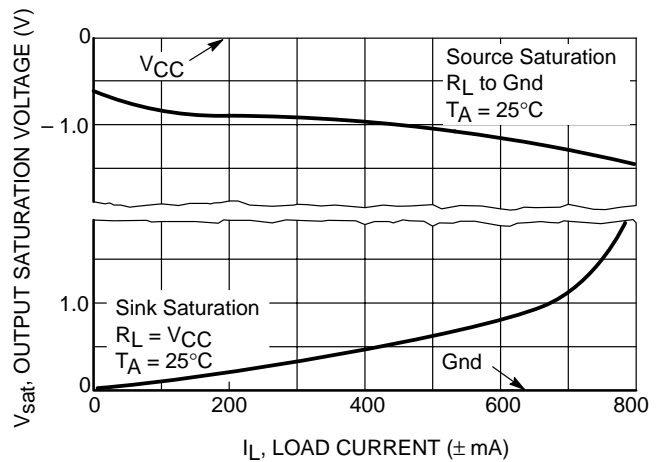

Figure 6. Output Driver Saturation versus Load Current

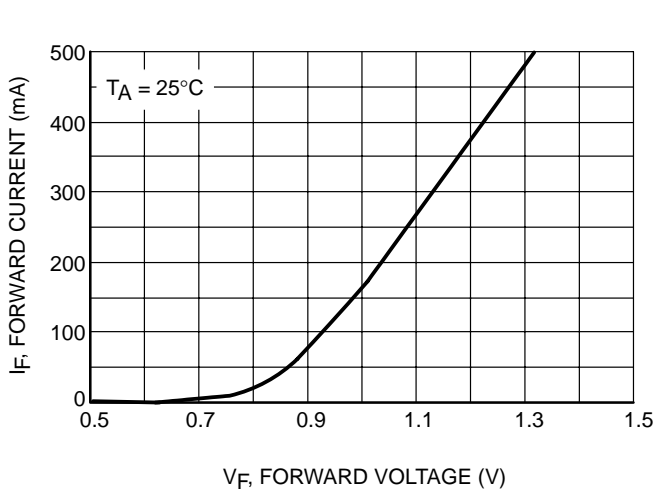

Figure 7. Brake Diode Forward Current versus Forward Voltage

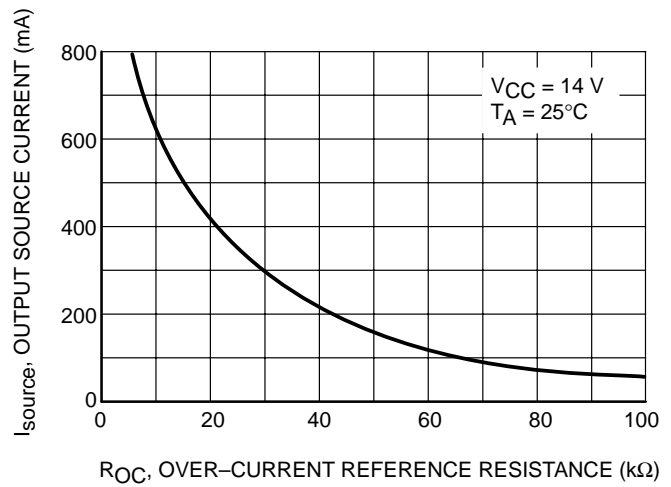

Figure 8. Output Source Current-Limit versus Over-Current Reference Resistance

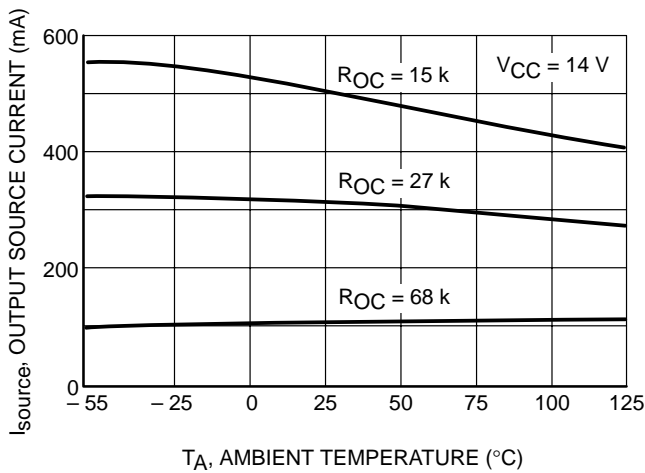

Figure 9. Output Source Current-Limit versus Temperature

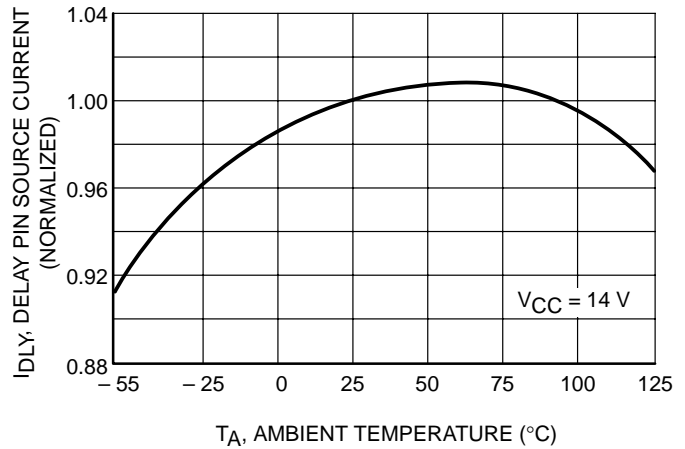

Figure 10. Normalized Delay Pin Source Current versus Temperature

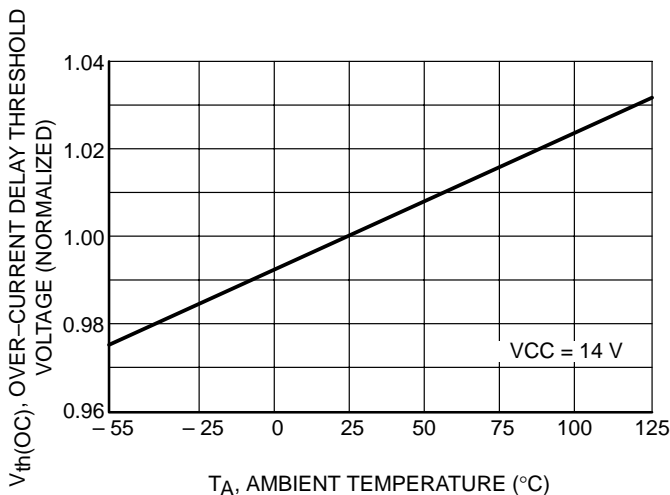

Figure 11. Normalized Over-Current Delay Threshold Voltage versus Temperature

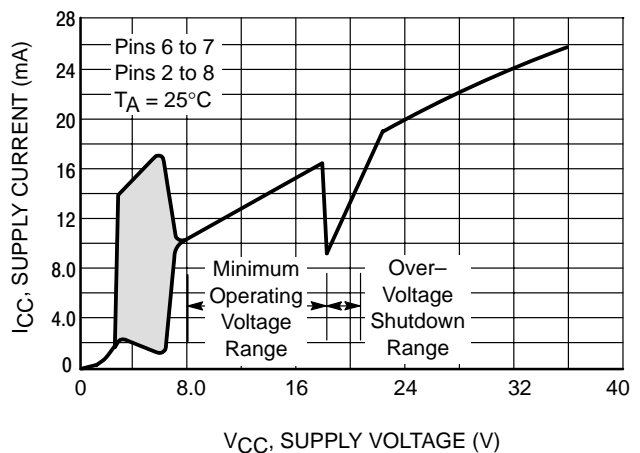

Figure 12. Supply Current versus Supply Voltage

MC33030

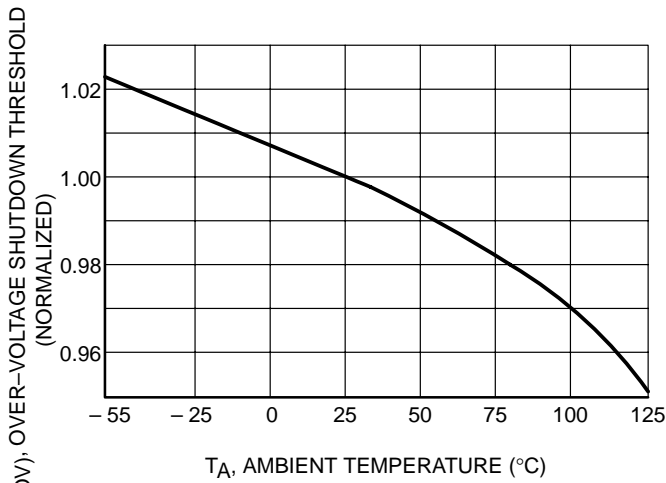

Figure 13. Normalized Over-Voltage Shutdown Threshold versus Temperature

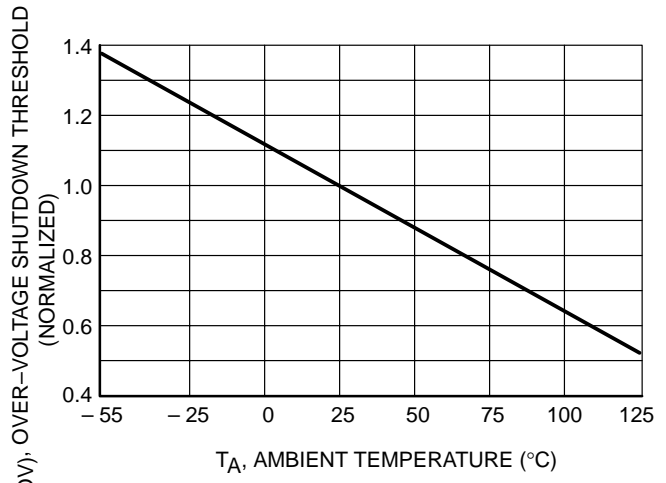

Figure 14. Normalized Over-Voltage Shutdown Hysteresis versus Temperature

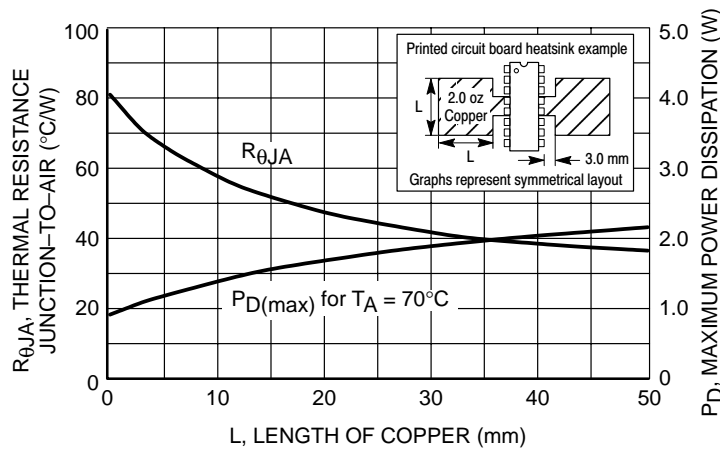

Figure 15. P Suffix (DIP-16) Thermal Resistance and Maximum Power Dissipation versus P.C.B. Copper Length

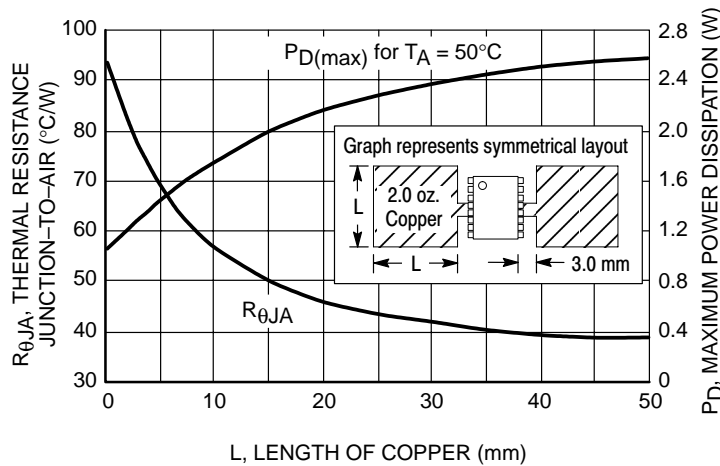

Figure 16. DW Suffix (SOP-16L) Thermal Resistance and Maximum Power Dissipation versus P.C.B. Copper Length

OPERATING DESCRIPTION

The MC33030 was designed to drive fractional horsepower DC motors and sense actuator position by voltage feedback. A typical servo application and representative internal block diagram are shown in Figure 17. The system operates by setting a voltage on the reference input of the Window Detector (Pin 1) which appears on (Pin 2). A DC motor then drives a position sensor, usually a potentiometer driven by a gear box, in a corrective fashion so that a voltage proportional to position is present at Pin 3. The servo motor will continue to run until the voltage at Pin 3 falls within the dead zone, which is centered about the reference voltage.

The Window Detector is composed of two comparators, A and B, each containing hysteresis. The reference input, common to both comparators, is pre-biased at $1/2 V_{CC}$ for simple two position servo systems and can easily be overridden by an external voltage divider. The feedback voltage present at Pin 3 is connected to the center of two resistors that are driven by an equal magnitude current source and sink. This generates an offset voltage at the input of each comparator which is centered about Pin 3 that can float virtually from V_{CC} to ground. The sum of the upper and lower offset voltages is defined as the window detector input dead zone range.

To increase system flexibility, an on-chip Error Amp is provided. It can be used to buffer and/or gain-up the actuator position voltage which has the effect of narrowing the dead zone range. A PNP differential input stage is provided so that the input common-mode voltage range will include ground. The main design goal of the error amp output stage was to be able to drive the window detector input. It typically can source 1.8 mA and sink 250 μ A. Special design considerations must be made if it is to be used for other applications.

The Power H-Switch provides a direct means for motor drive and braking with a maximum source, sink, and brake current of 1.0 A continuous. Maximum package power dissipation limits must be observed. Refer to Figure 15 for thermal information. For greater drive current requirements, a method for buffering that maintains all the system features is shown in Figure 30.

The Over-Current Monitor is designed to distinguish between motor start-up or locked rotor conditions that can occur when the actuator has reached its travel limit. A fraction of the Power H-Switch source current is internally fed into one of the two inverting inputs of the current comparator, while the non-inverting input is driven by a programmable current reference. This reference level is controlled by the resistance value selected for R_{OC} , and must be greater than the required motor run-current with its

mechanical load over temperature; refer to Figure 8. During an over-current condition, the comparator will turn off and allow the current source to charge the delay capacitor, C_{DLY} . When C_{DLY} charges to a level of 7.5 V, the set input of the over-current latch will go high, disabling the drive and brake functions of the Power H-Switch. The programmable time delay is determined by the capacitance value-selected for C_{DLY} .

$$t_{DLY} = \frac{V_{ref} C_{DLY}}{I_{DLY(source)}} = \frac{7.5 C_{DLY}}{5.5 \mu A} = 1.36 C_{DLY} \text{ in } \mu F$$

This system allows the Power H-Switch to supply motor start-up current for a predetermined amount of time. If the rotor is locked, the system will time-out and shut-down. This feature eliminates the need for servo end-of-travel or limit switches. Care must be taken so as not to select too large of a capacitance value for C_{DLY} . An over-current condition for an excessively long time-out period can cause the integrated circuit to overheat and eventually fail. Again, the maximum package power dissipation limits must be observed. The over-current latch is reset upon power-up or by readjusting $V_{Pin 2}$ as to cause $V_{Pin 3}$ to enter or pass through the dead zone. This can be achieved by requesting the motor to reverse direction.

An Over-Voltage Monitor circuit provides protection for the integrated circuit and motor by disabling the Power H-Switch functions if V_{CC} should exceed 18 V. Resumption of normal operation will commence when V_{CC} falls below 17.4 V.

A timing diagram that depicts the operation of the Drive/Brake Logic section is shown in Figure 18. The waveforms grouped in [1] show a reference voltage that was preset, appearing on Pin 2, which corresponds to the desired actuator position. The true actuator position is represented by the voltage on Pin 3. The points V_1 through V_4 represent the input voltage thresholds of comparators A and B that cause a change in their respective output state. They are defined as follows:

V_1 = Comparator B turn-off threshold

V_2 = Comparator A turn-on threshold

V_3 = Comparator A turn-off threshold

V_4 = Comparator B turn-on threshold

V_1-V_4 = Comparator B input hysteresis voltage

V_2-V_3 = Comparator A input hysteresis voltage

V_2-V_4 = Window detector input dead zone range

$|(V_2-V_{Pin2})-(V_{Pin2}-V_4)|$ = Window detector input voltage

MC33030

It must be remembered that points V_1 through V_4 always try to follow and center about the reference voltage setting if it is within the input common-mode voltage range of Pin 3; Figures 4 and 5. Initially consider that the feedback input voltage level is somewhere on the dashed line between V_2 and V_4 in [1]. This is within the dead zone range as defined above and the motor will be off. Now if the reference voltage is raised so that $V_{Pin\ 3}$ is less than V_4 , comparator B will turn-on [3] enabling \bar{Q} Drive, causing Drive Output A to sink and B to source motor current [8]. The actuator will move in Direction B until $V_{Pin\ 3}$ becomes greater than V_1 . Comparator B will turn-off, activating the brake enable [4]

and \bar{Q} Brake [6] causing Drive Output A to go high and B to go into a high impedance state. The inertia of the mechanical system will drive the motor as a generator creating a positive voltage on Pin 10 with respect to Pin 14. The servo system can be stopped quickly, so as not to over-shoot through the dead zone range, by braking. This is accomplished by shorting the motor/generator terminals together. Brake current will flow into the diode at Drive Output B, through the internal V_{CC} rail, and out the emitter of the sourcing transistor at Drive Output A. The end of the solid line and beginning of the dashed for $V_{Pin\ 3}$ [1] indicates the possible resting position of the actuator after braking.

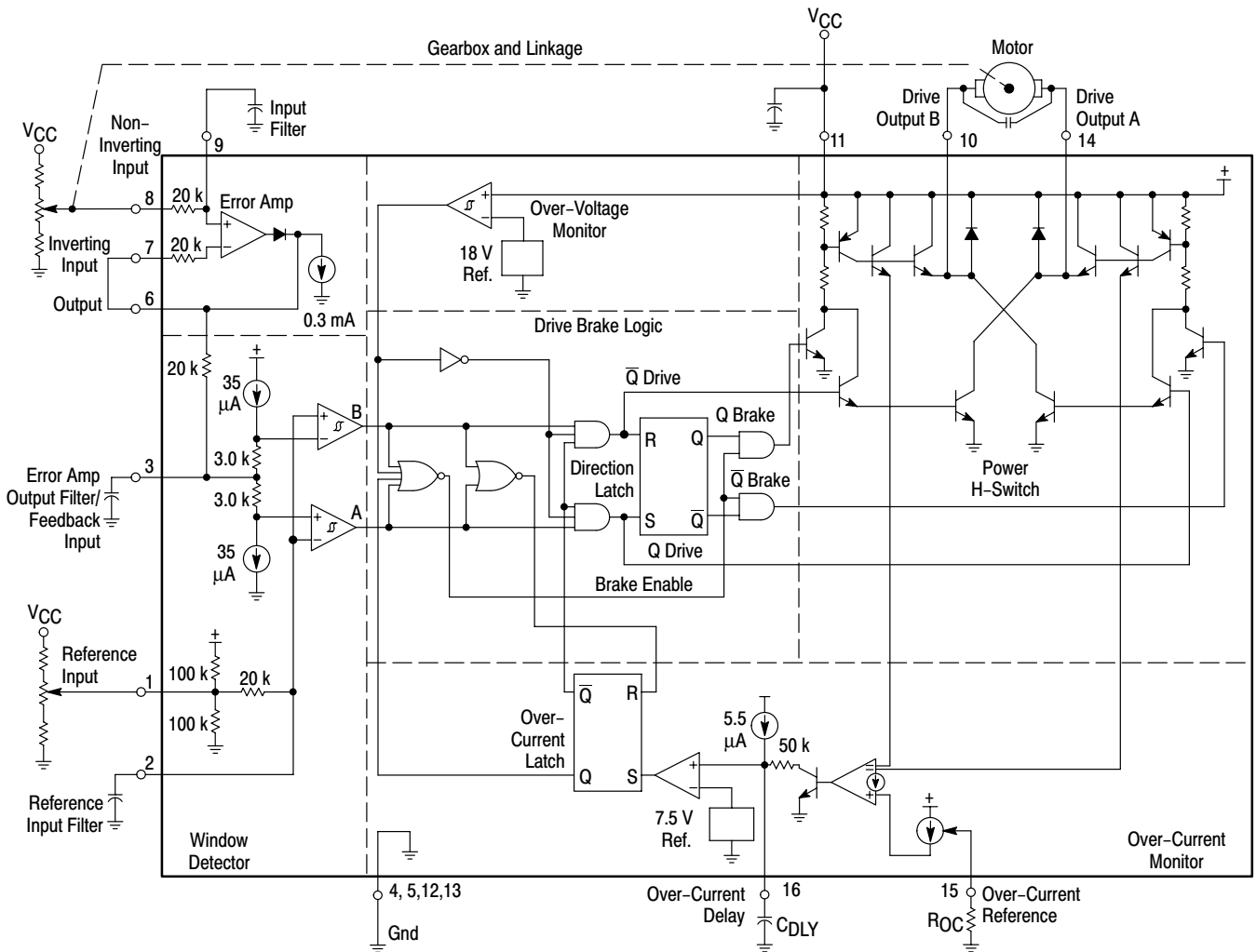

Figure 17. Representative Block Diagram and Typical Servo Application

If $V_{Pin\ 3}$ should continue to rise and become greater than V_2 , the actuator will have over shot the dead zone range and cause the motor to run in Direction A until $V_{Pin\ 3}$ is equal to V_3 . The Drive/Brake behavior for Direction A is identical to that of B. Overshooting the dead zone range in both directions can cause the servo system to continuously hunt or oscillate. Notice that the last motor run-direction is stored in the direction latch. This information is needed to determine whether Q or \bar{Q} Brake is to be enabled when $V_{Pin\ 3}$ enters the dead zone range. The dashed lines in [8,9] indicate the resulting waveforms of an over-current condition that has exceeded the programmed time delay. Notice that both Drive Outputs go into a high impedance state until $V_{Pin\ 2}$ is readjusted so that $V_{Pin\ 3}$ enters or crosses through the dead zone [7, 4].

The inputs of the Error Amp and Window Detector can be susceptible to the noise created by the brushes of the DC motor and cause the servo to hunt. Therefore, each of these inputs are provided with an internal series resistor and are pinned out for an external bypass capacitor. It has been found that placing a capacitor with *short leads* directly across the brushes will significantly reduce noise problems. Good quality RF bypass capacitors in the range of 0.001 to 0.1 μF may be required. Many of the more economical motors will generate significant levels of RF energy over a spectrum that extends from DC to beyond 200 MHz. The capacitance value and method of noise filtering must be determined on a system by system basis.

Thus far, the operating description has been limited to servo systems in which the motor mechanically drives a potentiometer for position sensing. Figures 19, 20, 27, and 31 show examples that use light, magnetic flux, temperature, and pressure as a means to drive the feedback element. Figures 21, 22 and 23 are examples of two position, open loop servo systems. In these systems, the motor runs the actuator to each end of its travel limit where the Over-Current Monitor detects a locked rotor condition and shuts down the drive. Figures 32 and 33 show two possible methods of using the MC33030 as a switching motor controller. In each example a fixed reference voltage is applied to Pin 2. This causes $V_{Pin\ 3}$ to be less than V_4 and Drive Output A, Pin 14, to be in a low state saturating the TIP42 transistor. In Figure 32, the motor drives a tachometer that generates an ac voltage proportional to RPM. This voltage is rectified, filtered, divided down by the speed set potentiometer, and applied to Pin. 8. The motor will accelerate until $V_{Pin\ 3}$ is equal to V_1 at which time Pin 14 will go to a high state and terminate the motor drive. The motor will now coast until $V_{Pin\ 3}$ is less than V_4 where upon drive is then reapplied. The system operation of Figure 31 is identical to that of 32 except the signal at Pin 3 is an amplified average of the motors drive and back EMF voltages. Both systems exhibit excellent control of RPM with variations of V_{CC} ; however, Figure 32 has somewhat better torque characteristics at low RPM.

MC33030

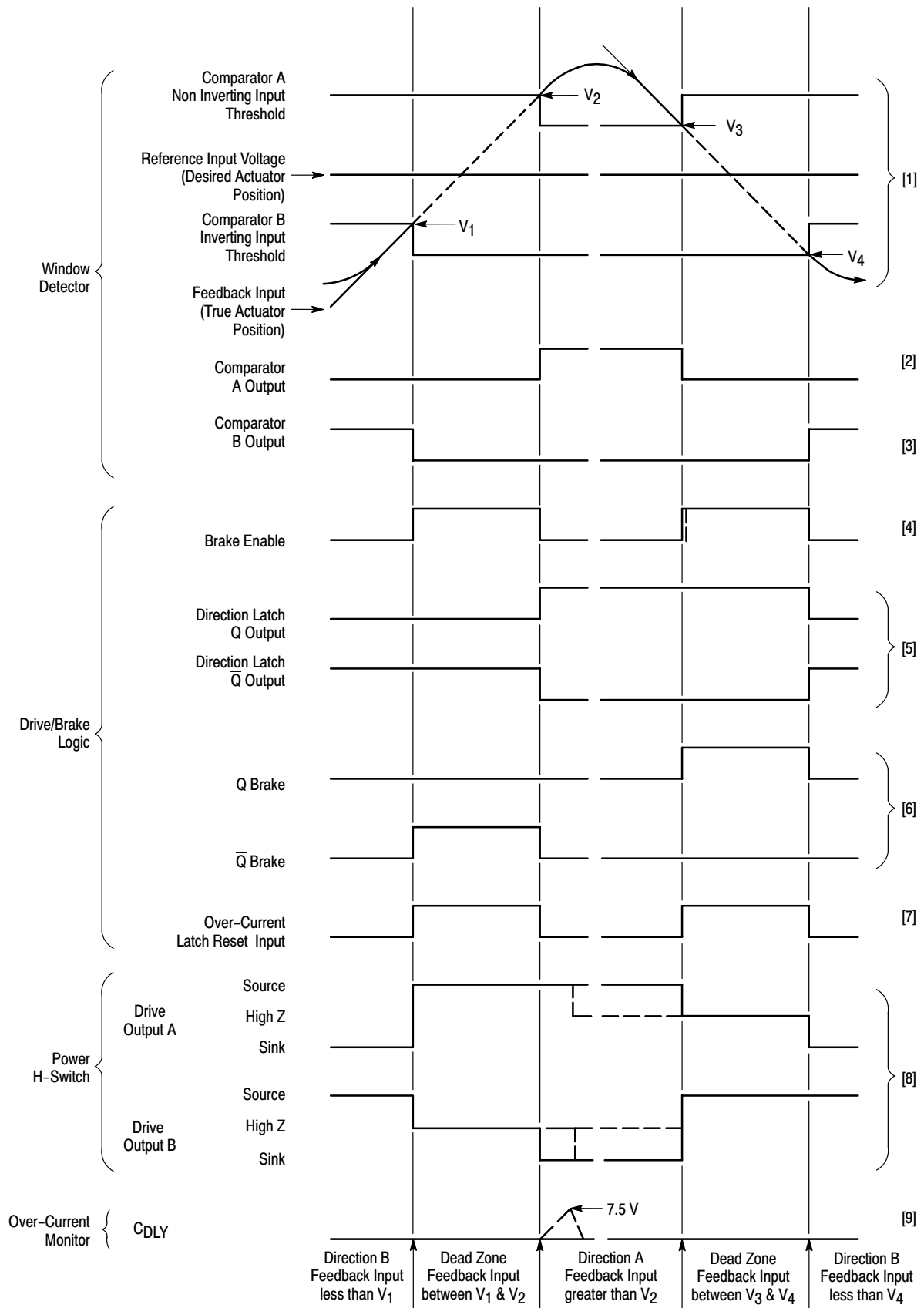

Figure 18. Timing Diagram

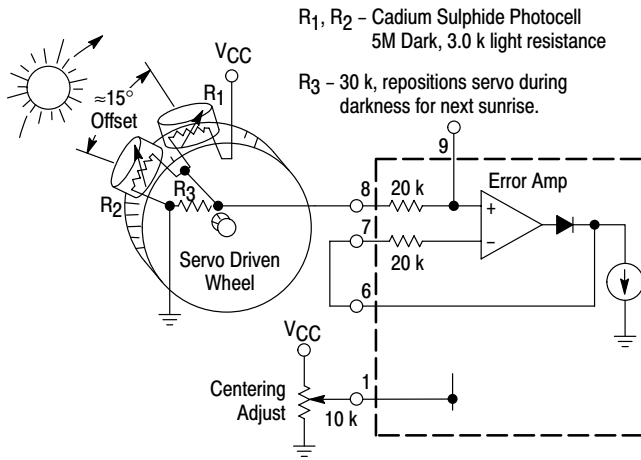
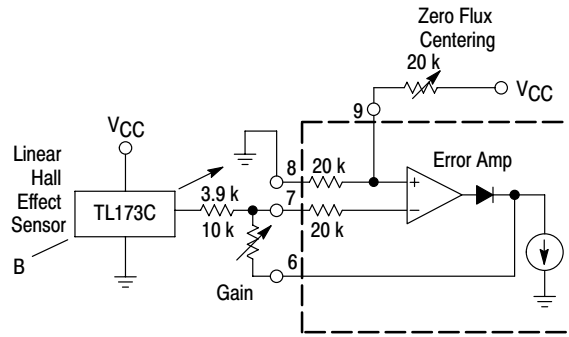
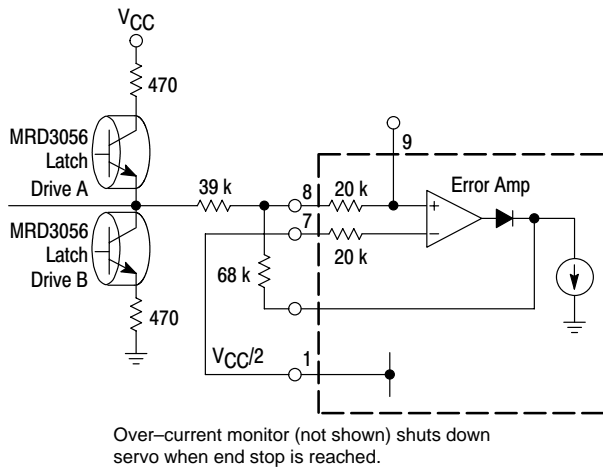

Figure 19. Solar Tracking Servo System



Typical sensitivity with gain set at 3.9 k is 1.5 mV/gauss. Servo motor controls magnetic field about sensor.

Figure 20. Magnetic Sensing Servo System



Over-current monitor (not shown) shuts down servo when end stop is reached.

Figure 21. Infrared Latched Two Position Servo System

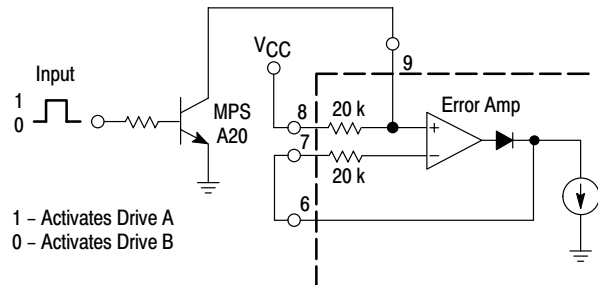

Over-current monitor (not shown) shuts down servo when end stop is reached.

Figure 22. Digital Two Position Servo System

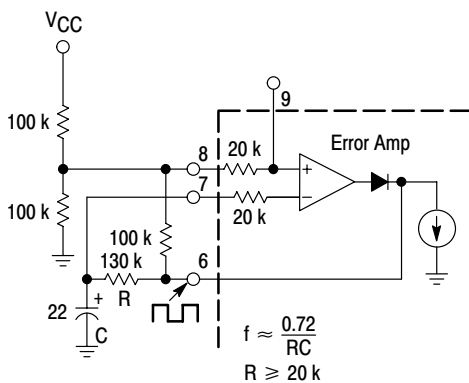

Figure 23. 0.25 Hz Square-Wave Servo Actuator

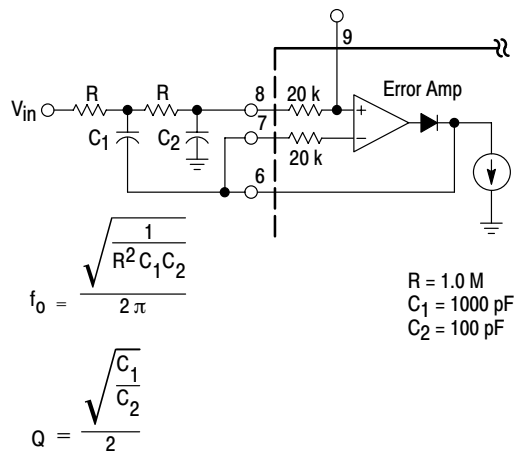
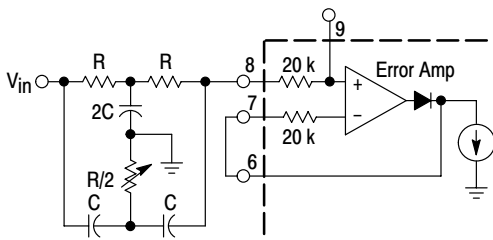

Figure 24. Second Order Low-Pass Active Filter



$$f_{\text{notch}} = \frac{1}{2\pi RC}$$

For 60 Hz R = 53.6 k, C = 0.05

Figure 25. Notch Filter

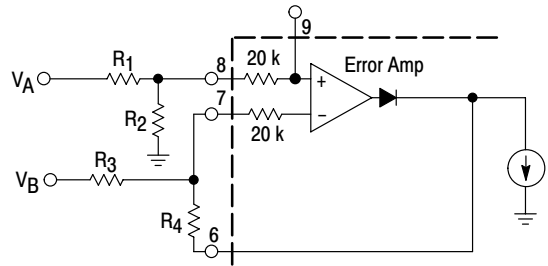

$$V_{\text{Pin 6}} = V_A \left(\frac{R_3 + R_4}{R_1 + R_2} \right) \frac{R_2}{R_3} - \left(\frac{R_4}{R_3} V_B \right)$$

Figure 26. Differential Input Amplifier

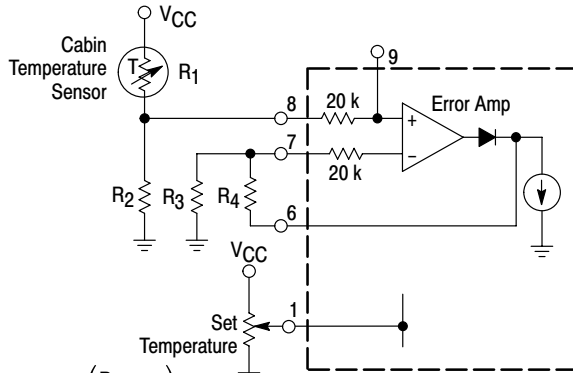

$$V_{\text{Pin 6}} = \frac{V_{CC} \left(\frac{R_4}{R_3} + 1 \right)}{\left(\frac{R_1}{R_2} + 1 \right)}$$

In this application the servo motor drives the heat/air conditioner modulator door in a duct system.

Figure 27. Temperature Sensing Servo System

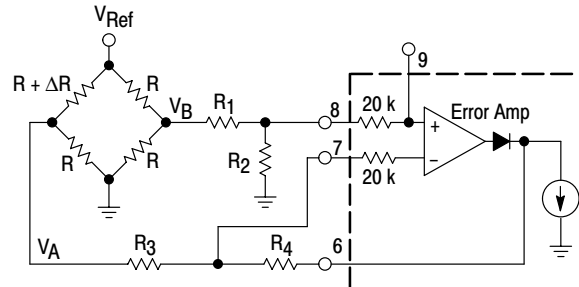

$$V_A - V_B = V_{\text{Ref}} \left(\frac{\Delta R}{4R + 2\Delta R} \right)$$

$$R_1 = R_3, R_2 = R_4, R_1 \gg R$$

$$V_{\text{Pin 6}} = \frac{R_4}{R_3} (V_A - V_B)$$

Figure 28. Bridge Amplifier

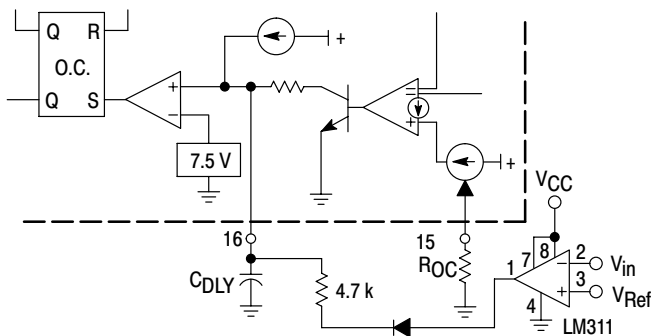

A direction change signal is required at Pins 2 or 3 to reset the over-current latch.

Figure 29. Remote Latched Shutdown

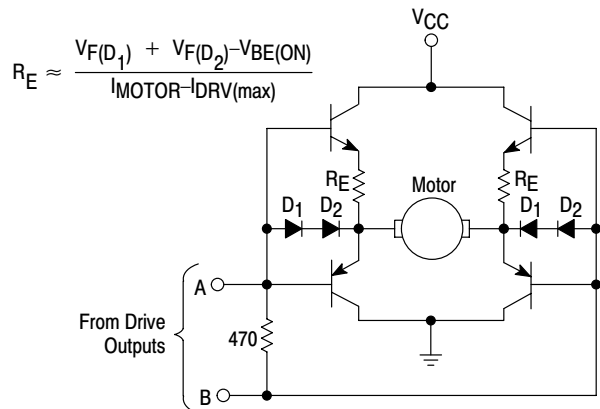

$$I_E \approx \frac{V_F(D_1) + V_F(D_2) - V_{BE(ON)}}{I_{\text{MOTOR}} - I_{\text{DRV(max)}}$$

This circuit maintains the brake and over-current features of the MC33030. Set ROC to 15 k for I_{DRV(max)} = 0.5 A.

Figure 30. Power H-Switch Buffer

MC33030

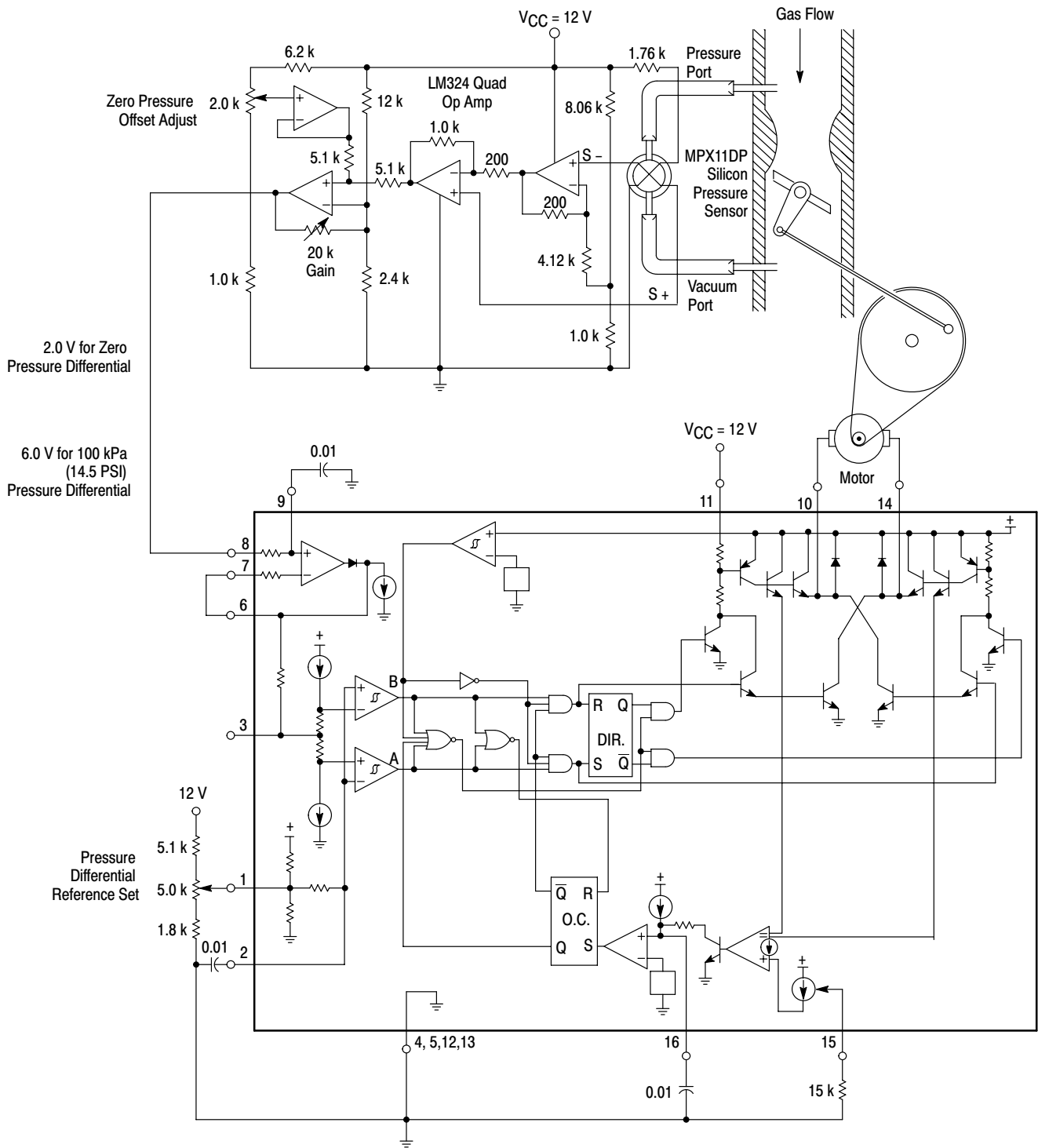
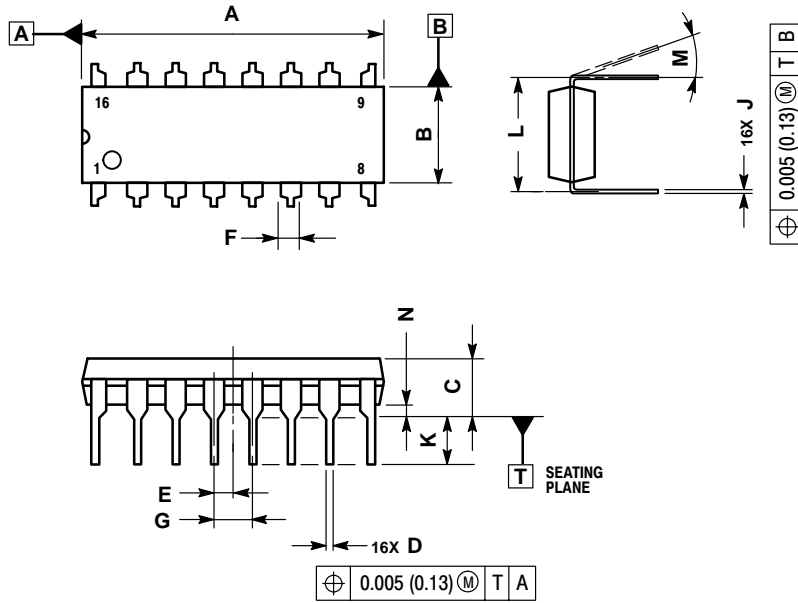

Figure 31. Adjustable Pressure Differential Regulator

MC33030

PACKAGE DIMENSIONS

PDIP-16
P SUFFIX
CASE 648C-04
ISSUE D



- NOTES:
1. DIMENSIONING AND TOLERANCING PER ASME Y14.5M, 1994.
 2. CONTROLLING DIMENSION: INCH.
 3. DIMENSION L TO CENTER OF LEADS WHEN FORMED PARALLEL.
 4. DIMENSION B DOES NOT INCLUDE MOLD FLASH.

DIM	INCHES		MILLIMETERS	
	MIN	MAX	MIN	MAX
A	0.744	0.783	18.90	19.90
B	0.240	0.260	6.10	6.60
C	0.145	0.185	3.69	4.69
D	0.015	0.021	0.38	0.53
E	0.050 BSC		1.27 BSC	
F	0.040	0.70	1.02	1.78
G	0.100 BSC		2.54 BSC	
J	0.008	0.015	0.20	0.38
K	0.115	0.135	2.92	3.43
L	0.300 BSC		7.62 BSC	
M	0°	10°	0°	10°
N	0.015	0.040	0.39	1.01

SO-16W
DW SUFFIX
CASE 751G-03
ISSUE B

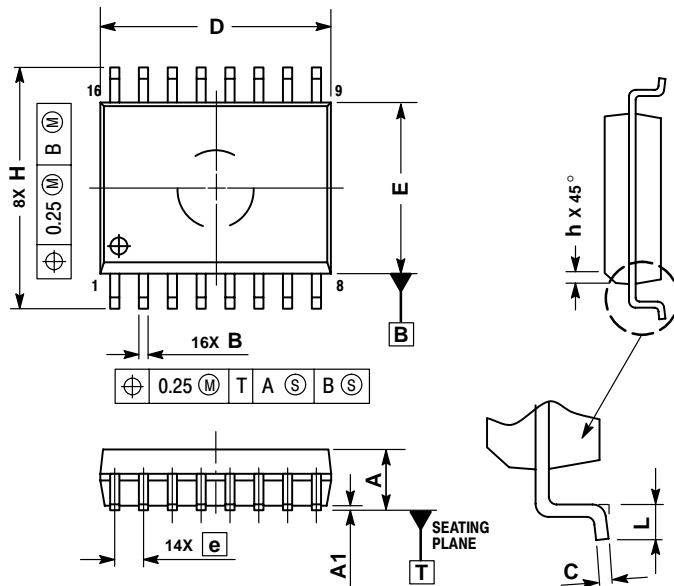

- NOTES:
1. DIMENSIONS ARE IN MILLIMETERS.
 2. INTERPRET DIMENSIONS AND TOLERANCES PER ASME Y14.5M, 1994.
 3. DIMENSIONS D AND E DO NOT INCLUDE MOLD PROTRUSION.
 4. MAXIMUM MOLD PROTRUSION 0.15 PER SIDE.
 5. DIMENSION B DOES NOT INCLUDE DAMBAR PROTRUSION. ALLOWABLE DAMBAR PROTRUSION SHALL BE 0.13 TOTAL IN EXCESS OF THE B DIMENSION AT MAXIMUM MATERIAL CONDITION.

DIM	MILLIMETERS	
	MIN	MAX
A	2.35	2.65
A1	0.10	0.25
B	0.35	0.49
C	0.23	0.32
D	10.15	10.45
E	7.40	7.60
e	1.27 BSC	
H	10.05	10.55
h	0.25	0.75
L	0.50	0.90
θ	0°	7°

ON Semiconductor and  are trademarks of Semiconductor Components Industries, LLC (SCILLC). SCILLC reserves the right to make changes without further notice to any products herein. SCILLC makes no warranty, representation or guarantee regarding the suitability of its products for any particular purpose, nor does SCILLC assume any liability arising out of the application or use of any product or circuit, and specifically disclaims any and all liability, including without limitation special, consequential or incidental damages. "Typical" parameters which may be provided in SCILLC data sheets and/or specifications can and do vary in different applications and actual performance may vary over time. All operating parameters, including "Typicals" must be validated for each customer application by customer's technical experts. SCILLC does not convey any license under its patent rights nor the rights of others. SCILLC products are not designed, intended, or authorized for use as components in systems intended for surgical implant into the body, or other applications intended to support or sustain life, or for any other application in which the failure of the SCILLC product could create a situation where personal injury or death may occur. Should Buyer purchase or use SCILLC products for any such unintended or unauthorized application, Buyer shall indemnify and hold SCILLC and its officers, employees, subsidiaries, affiliates, and distributors harmless against all claims, costs, damages, and expenses, and reasonable attorney fees arising out of, directly or indirectly, any claim of personal injury or death associated with such unintended or unauthorized use, even if such claim alleges that SCILLC was negligent regarding the design or manufacture of the part. SCILLC is an Equal Opportunity/Affirmative Action Employer.

PUBLICATION ORDERING INFORMATION

Literature Fulfillment:

Literature Distribution Center for ON Semiconductor
P.O. Box 5163, Denver, Colorado 80217 USA
Phone: 303-675-2175 or 800-344-3860 Toll Free USA/Canada
Fax: 303-675-2176 or 800-344-3867 Toll Free USA/Canada
Email: ONlit@hibbertco.com

N. American Technical Support: 800-282-9855 Toll Free USA/Canada

JAPAN: ON Semiconductor, Japan Customer Focus Center
4-32-1 Nishi-Gotanda, Shinagawa-ku, Tokyo, Japan 141-0031
Phone: 81-3-5740-2700
Email: r14525@onsemi.com

ON Semiconductor Website: <http://onsemi.com>

For additional information, please contact your local Sales Representative.