

12 Watt Dual Series DC/DC Converters

Features

- Low Noise Output
- LC Type Input Filter
- Six-Sided Shielded Steel Case
- Very Wide Input Voltage Ranges (9-36, 18-54, and 24-72)
- High Efficiency Operation
- Long Term Output Fault Survival
- 5 Year Warranty

Description

These 10 and 12 Watt Dual Output DC/DC converters are designed for telecommunications, medical or industrial equipment and instrumentation systems. The converters feature very wide input voltage ranges.

The converter consists of a hi-speed chopper circuit using state of the art MOSFET technology, isolation transformer, and high regulation linear post regulator. This provides for very low noise and ultra stable output voltages.

Selection Chart				
Model	Input Range VDC		Outputs VDC	Outputs mA
	MIN	MAX		
24D12.500	9.00	36.00	±12.0	±500
24D15.400	9.00	36.00	±15.0	±400
28D5.1000	18.00	54.00	±5.0	±1000
48D12.500	24.00	72.00	±12.0	±500
48D15.400	24.00	72.00	±15.0	±400

12 Watt Dual Series Block Diagram

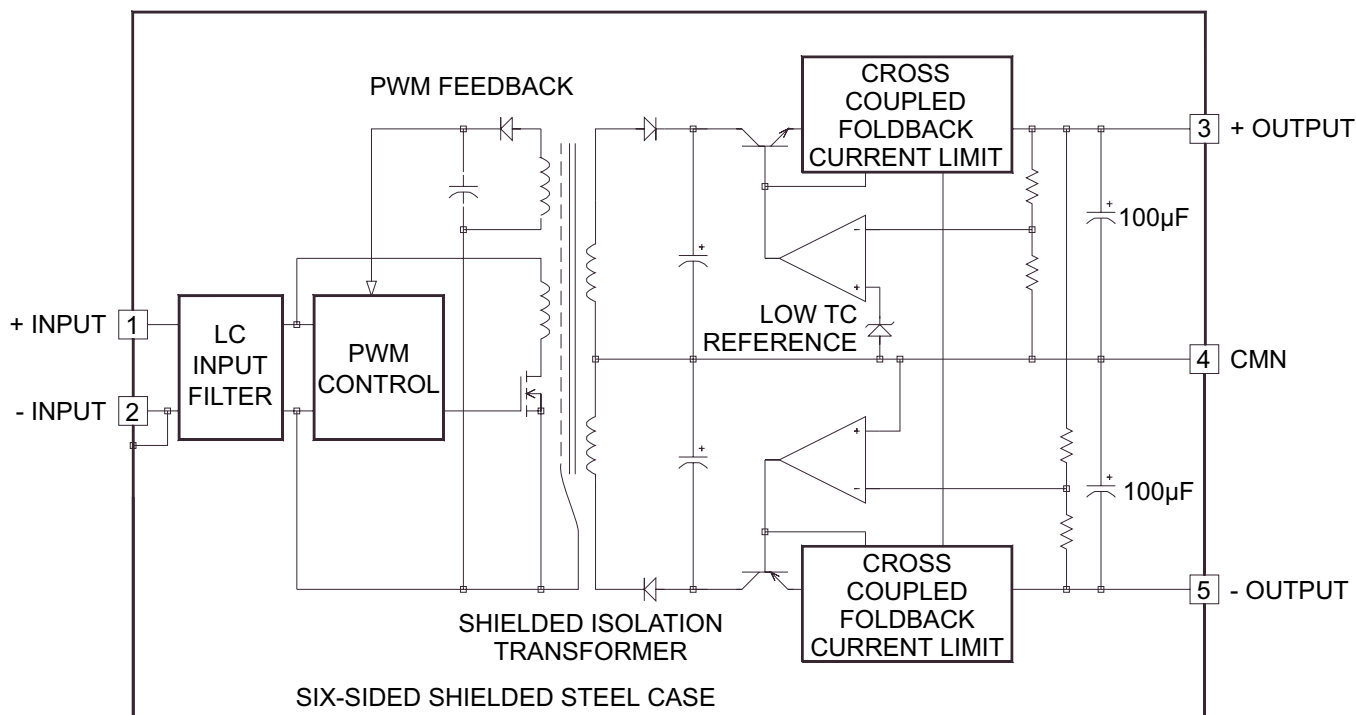

12 Watt Dual Series DC/DC Converters

Input Parameters*					
Model		24D12.500	24D15.400		Units
Voltage Range	MIN	9.00			VDC
	MAX	36.00			
Reflected Ripple, 0-20MHz bw	TYP	20			mA P-P
	MAX	45			
Input Current Full Load No Load	TYP	710	700		mA
	TYP	40	40		
Efficiency	TYP	70			%
Switching Frequency	TYP	100			kHz
Maximum Input Overvoltage, 100ms No damage	MAX	40			VDC
Turn-on Time, 1% Output Error	TYP	60			ms
Recommended Fuse	(2)				
Model		28D5.1000	48D12.500	48D15.400	Units
Voltage Range	MIN	18.00	24.00		VDC
	MAX	54.00	72.00		
Reflected Ripple, 0-20MHz bw	TYP	20	15		mA P-P
	MAX	50	30		
Input Current Full Load No Load	TYP	600	360	350	mA
	TYP	40	24	24	
Efficiency	TYP	60	70		%
Switching Frequency	TYP	87	100		kHz
Maximum Input Overvoltage, 100ms No damage	MAX	60	80		VDC
Turn-on Time, 1% Output Error	TYP	60			ms
Recommended Fuse	(2)				

Output Parameters*					
MODEL		28D5.1000	24D12.500 48D12.500	24D15.400 48D15.400	Units
Output Voltage		±5	±12	±15	VDC
Rated Current (3)	MIN	0	0	0	mA
	MAX	+1100/-900	±500	±400	
Voltage Range 100% Load	MIN	4.95	11.90	14.90	VDC
	TYP	5.00	12.00	15.00	
	MAX	5.05	12.10	15.10	
Output Balance (Plus to Minus Output, Full Load)	TYP	0.6			%
	MAX	1.0			
Load Regulation 0-100% Load	TYP	0.05	0.02	0.02	%
	MAX	0.10	0.07	0.07	
Line Regulation Vin = Min-Max VDC	TYP	0.02			%
	MAX	0.07			
Short Term Stability (4)	TYP	0.02			%
Long Term Stability	TYP	0.3			%/kHrs
Transient Response (5)	TYP	20			µs
Dynamic Response (6)	TYP	20			mV peak
Input Ripple Rejection (7)	TYP	60			dB
Noise, 0-20MHz bw	TYP	10			mV P-P
	MAX	40			
Temperature Coefficient	TYP	100	50	50	ppm/°C
	MAX	300	150	150	
Short Circuit Protection to Common for all Outputs	Continuous, 8 Hours Minimum Current Limit				

NOTES

* All parameters measured at Tc=25°C, nominal input voltage and full rated load unless otherwise noted. Refer to the CALEX Application Notes for the definition of terms, measurement circuits and other information.

(2) Determine the correct fuse size by calculating the maximum DC current drain at low line input, maximum load then adding 20 to 25 percent.

(3) No minimum load required.

(4) Short term stability is specified after a 30 minute warm-up at full load.

(5) Transient response is defined as the time for the output to settle from a 100% step load change to a 1% error band (rise time of step = 2µSec).

(6) Dynamic response is defined as the peak overshoot during a transient as defined in note 5 above.



12 Watt Dual Series DC/DC Converters

General Specifications *			
All Models			Units
Isolation			
Isolation Voltage	MIN	500	VDC
10µA Leakage Input-Output			
Input to Output Capacitance	TYP	120	pF
Environmental			
Case Operating Range No Derating	MIN	-25	°C
	MAX	80	
Case Functional Range (8)	MIN	-40	°C
	MAX	85	
Storage Range	MIN	-55	°C
	MAX	100	
Thermal Impedance (9)	TYP	6	°C/Watt
General			
Unit Weight	TYP	6.5	oz
Mounting Kits	MK215-022 & MK215-08BDV		

- (7) The input ripple rejection is specified for DC to 120Hz ripple with a modulation amplitude of 1% of V_{in} .
- (8) The functional temperature range is intended to give an additional data point for use in evaluating this power supply. At the low functional temperature the power supply will function with no side effects, however sustained operation at the high functional temperature will reduce expected operational life. The data sheet specifications are not guaranteed over the functional temperature range.
- (9) The case thermal impedance is specified as the case temperature rise over ambient per package watt dissipated.

Typical Performance ($T_c=25^\circ\text{C}$, Full Rated Load).

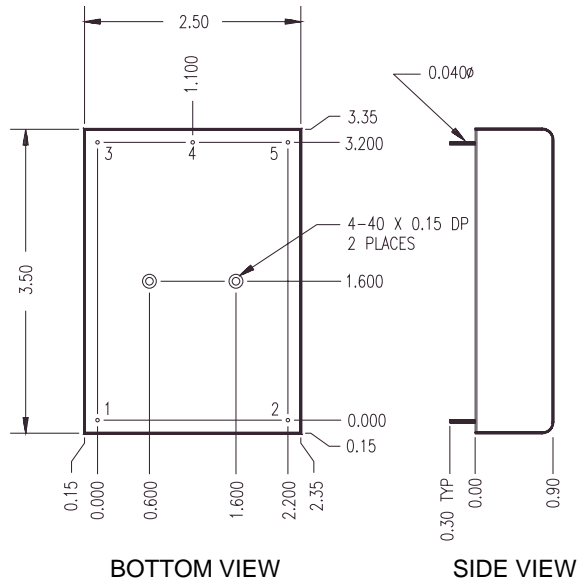

Mechanical tolerances unless otherwise noted:

X.XX dimensions: ± 0.020 inches

X.XXX dimensions: ± 0.005 inches

Pin	Function
1	+INPUT
2	-INPUT
3	+OUTPUT
4	CMN
5	-OUTPUT

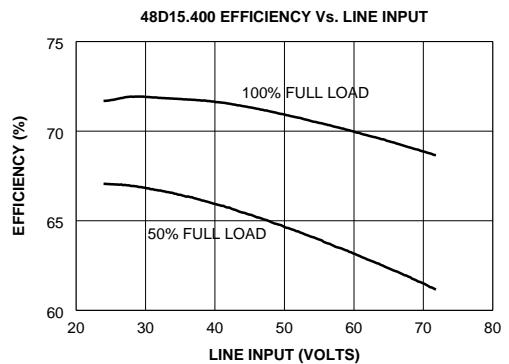
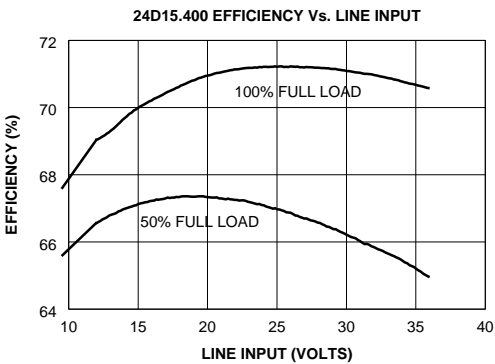

12 Watt Dual Series DC/DC Converters

Typical Performance ($T_c=25^\circ\text{C}$, Full Rated Load).

