

NEC

User's Manual

IE-780958-NS-EM4

Emulation Board

Target Devices
μPD780958 Subseries

Document No. U16266EJ2V0UM00 (2nd edition)
Date Published September 2002 N CP(K)

© NEC Corporation 2002
Printed in Japan

[MEMO]

Windows is either a registered trademark or a trademark of Microsoft Corporation in the United States and/or other countries.

PC/AT is a trademark of International Business Machines Corporation.

- **The information in this document is current as of September, 2002. The information is subject to change without notice. For actual design-in, refer to the latest publications of NEC's data sheets or data books, etc., for the most up-to-date specifications of NEC semiconductor products. Not all products and/or types are available in every country. Please check with an NEC sales representative for availability and additional information.**

- No part of this document may be copied or reproduced in any form or by any means without prior written consent of NEC. NEC assumes no responsibility for any errors that may appear in this document.

- NEC does not assume any liability for infringement of patents, copyrights or other intellectual property rights of third parties by or arising from the use of NEC semiconductor products listed in this document or any other liability arising from the use of such products. No license, express, implied or otherwise, is granted under any patents, copyrights or other intellectual property rights of NEC or others.

- Descriptions of circuits, software and other related information in this document are provided for illustrative purposes in semiconductor product operation and application examples. The incorporation of these circuits, software and information in the design of customer's equipment shall be done under the full responsibility of customer. NEC assumes no responsibility for any losses incurred by customers or third parties arising from the use of these circuits, software and information.

- While NEC endeavours to enhance the quality, reliability and safety of NEC semiconductor products, customers agree and acknowledge that the possibility of defects thereof cannot be eliminated entirely. To minimize risks of damage to property or injury (including death) to persons arising from defects in NEC semiconductor products, customers must incorporate sufficient safety measures in their design, such as redundancy, fire-containment, and anti-failure features.

- NEC semiconductor products are classified into the following three quality grades: "Standard", "Special" and "Specific". The "Specific" quality grade applies only to semiconductor products developed based on a customer-designated "quality assurance program" for a specific application. The recommended applications of a semiconductor product depend on its quality grade, as indicated below. Customers must check the quality grade of each semiconductor product before using it in a particular application.

"Standard": Computers, office equipment, communications equipment, test and measurement equipment, audio and visual equipment, home electronic appliances, machine tools, personal electronic equipment and industrial robots

"Special": Transportation equipment (automobiles, trains, ships, etc.), traffic control systems, anti-disaster systems, anti-crime systems, safety equipment and medical equipment (not specifically designed for life support)

"Specific": Aircraft, aerospace equipment, submersible repeaters, nuclear reactor control systems, life support systems and medical equipment for life support, etc.

The quality grade of NEC semiconductor products is "Standard" unless otherwise expressly specified in NEC's data sheets or data books, etc. If customers wish to use NEC semiconductor products in applications not intended by NEC, they must contact an NEC sales representative in advance to determine NEC's willingness to support a given application.

(Note)

(1) "NEC" as used in this statement means NEC Corporation and also includes its majority-owned subsidiaries.

(2) "NEC semiconductor products" means any semiconductor product developed or manufactured by or for NEC (as defined above).

M8E 00.4

Regional Information

Some information contained in this document may vary from country to country. Before using any NEC product in your application, please contact the NEC office in your country to obtain a list of authorized representatives and distributors. They will verify:

- Device availability
- Ordering information
- Product release schedule
- Availability of related technical literature
- Development environment specifications (for example, specifications for third-party tools and components, host computers, power plugs, AC supply voltages, and so forth)
- Network requirements

In addition, trademarks, registered trademarks, export restrictions, and other legal issues may also vary from country to country.

NEC Electronics Inc. (U.S.)

Santa Clara, California
Tel: 408-588-6000
800-366-9782
Fax: 408-588-6130
800-729-9288

NEC do Brasil S.A.

Electron Devices Division
Guarulhos-SP, Brasil
Tel: 11-6462-6810
Fax: 11-6462-6829

NEC Electronics (Europe) GmbH

Duesseldorf, Germany
Tel: 0211-65 03 01
Fax: 0211-65 03 327

• **Sucursal en España**

Madrid, Spain
Tel: 091-504 27 87
Fax: 091-504 28 60

• **Succursale Française**

Vélizy-Villacoublay, France
Tel: 01-30-67 58 00
Fax: 01-30-67 58 99

• **Filiale Italiana**

Milano, Italy
Tel: 02-66 75 41
Fax: 02-66 75 42 99

• **Branch The Netherlands**

Eindhoven, The Netherlands
Tel: 040-244 58 45
Fax: 040-244 45 80

• **Branch Sweden**

Taeby, Sweden
Tel: 08-63 80 820
Fax: 08-63 80 388

• **United Kingdom Branch**

Milton Keynes, UK
Tel: 01908-691-133
Fax: 01908-670-290

NEC Electronics Hong Kong Ltd.

Hong Kong
Tel: 2886-9318
Fax: 2886-9022/9044

NEC Electronics Hong Kong Ltd.

Seoul Branch
Seoul, Korea
Tel: 02-528-0303
Fax: 02-528-4411

NEC Electronics Shanghai, Ltd.

Shanghai, P.R. China
Tel: 021-6841-1138
Fax: 021-6841-1137

NEC Electronics Taiwan Ltd.

Taipei, Taiwan
Tel: 02-2719-2377
Fax: 02-2719-5951

NEC Electronics Singapore Pte. Ltd.

Novena Square, Singapore
Tel: 253-8311
Fax: 250-3583

INTRODUCTION

Product Overview

The IE-780958-NS-EM4 is designed to be used with the IE-78K0-NS or IE-78K0-NS-A and IE-78K0-NS-P02 to debug the following target devices that belong to the 78K/0 Series of 8-bit single-chip microcontrollers.

- μ PD780958 Subseries: μ PD780957(A), 780958(A)

Target Readers

This manual is intended for engineers who will use the IE-780958-NS-EM4 with the IE-78K0-NS or IE-78K0-NS-A and IE-78K0-NS-P02 to perform system debugging. Engineers who use this manual are expected to be thoroughly familiar with the target device's functions and use methods and to be knowledgeable about debugging.

Organization

When using the IE-780958-NS-EM4, refer to not only this manual (supplied with the IE-780958-NS-EM4) but also the manuals that are supplied with the IE-78K0-NS-P02 and the IE-78K0-NS or IE-78K0-NS-A.

The IE-78K0-NS used in combination with the IE-78K0-NS-PA is functionally equivalent to the IE-78K0-NS-A. Therefore, as necessary, read IE-78K0-NS + IE-78K0-NS-PA for IE-78K0-NS-A in this document.

IE-78K0-NS or IE-78K0-NS-A User's Manual

- Basic specifications
- System configuration
- External interface functions

IE-780958-NS-EM4 User's Manual

- General
- Part names
- Installation
- Differences between target devices and target interface circuits

IE-78K0-NS-P02 User's Manual

- General
- Part names
- Installation

Purpose

The purpose of this manual is to explain various debugging functions that can be performed when using the IE-780958-NS-EM4.

Terminology

The meanings of certain terms used in this manual are listed below.

Term	Meaning
Emulation device	This is a general term that refers to the device in the emulator that is used to emulate the target device. It includes the emulation CPU.
Emulation CPU	This is the CPU block in the emulator that is used to execute user-generated programs.
Target device	This is the device that is the target for emulation.
Target system	This includes the target program and the hardware provided by the user. When defined narrowly, it includes only the hardware.
IE system	This refers to the combination of the in-circuit emulator (IE-78K0-NS or IE-78K0-NS-A), the I/O board (IE-78K0-NS-P02), and the emulation board (IE-780958-NS-EM4).

Conventions

Data significance: Higher digits on the left and lower digits on the right

Note: Footnote for item marked with **Note** in the text

Caution: Information requiring particular attention

Remark: Supplementary information

Related Documents

The related documents (user's manuals) indicated in this publication may include preliminary versions. However, preliminary versions are not marked as such.

Document Name	Document No.
IE-78K0-NS In-Circuit Emulator	U13731E
IE-78K0-NS-A In-Circuit Emulator	U14889E
IE-78K0-NS-P02 I/O Board	U16108E
IE-780958-NS-EM4 Emulation Board	This manual
ID78K Series Integrated Debugger Ver. 2.30 or Later Operation Windows™ Based	U15185E
μPD780958 Subseries	U13655E

Caution The documents listed above are subject to change without notice. Be sure to use the latest documents when designing.

CONTENTS

CHAPTER 1 GENERAL	10
1.1 System Configuration.....	11
1.2 Hardware Configuration.....	13
1.3 Basic Specifications.....	14
CHAPTER 2 PART NAMES	15
2.1 Parts of Main Unit	16
CHAPTER 3 INSTALLATION	17
3.1 Connection.....	18
3.2 Clock Settings.....	19
3.2.1 Overview of clock settings	19
3.2.2 Main system clock settings	23
3.2.3 Subsystem clock 1 settings	27
3.2.4 Subsystem clock 2 settings	28
3.3 External Trigger	31
3.4 Jumper Settings on IE-78K0-NS.....	32
3.5 Jumper Settings on IE-78K0-NS-A	32
3.6 Jumper Settings on IE-780958-NS-EM4	32
3.7 Low Voltage Emulation Setting	33
CHAPTER 4 DIFFERENCES BETWEEN TARGET DEVICES AND TARGET INTERFACE CIRCUITS	34
CHAPTER 5 RESTRICTIONS	37
APPENDIX A EMULATION PROBE PIN ASSIGNMENT TABLE	39
APPENDIX B CAUTIONS ON DESIGNING TARGET SYSTEM	41

LIST OF FIGURES

Figure No.	Title	Page
1-1	System Configuration	11
1-2	Basic Hardware Configuration (Using IE-78K0-NS)	13
1-3	Basic Hardware Configuration (Using IE-78K0-NS-A).....	13
2-1	IE-780958-NS-EM4 Part Names.....	16
3-1	Connection of Emulation Probe	18
3-2	External Circuits Used as System Clock Oscillator	19
3-3	When Using Clock That Is Already Mounted on Emulation Board (Main System Clock)	20
3-4	When Using Clock That Is Already Mounted on Emulation Board (Subsystem Clock 1)	20
3-5	When Using Clock That Is Already Mounted on Emulation Board (Subsystem Clock 2)	21
3-6	When Using User-Mounted Clock (Main System Clock)	21
3-7	When Using User-Mounted Clock (Subsystem Clock 2)	22
3-8	When Using External Clock.....	22
3-9	Connections on Parts Board (When Using Main System Clock or User-Mounted Clock)	24
3-10	Crystal Oscillator (When Using Main System Clock or User-Mounted Clock)	26
3-11	Pin Alignment of Crystal Oscillator and Socket	26
3-12	Connections on Parts Board (When Using Subsystem Clock 2 or User-Mounted Clock)	29
3-13	Crystal Oscillator (When Using Subsystem Clock 2 or User-Mounted Clock)	30
3-14	Pin Alignment of Crystal Oscillator and Socket	30
3-15	External Trigger Input Position	31
3-16	IE-78K0-NS or IE-78K0-NS-A Main Board (G-780009 Board).....	33
4-1	Equivalent Circuit 1 of Emulation Circuit.....	35
4-2	Equivalent Circuit 2 of Emulation Circuit.....	35
4-3	Equivalent Circuit 3 of Emulation Circuit.....	36
4-4	Equivalent Circuit 4 of Emulation Circuit.....	36
5-1	Configuration of V _{LC1} and V _{LC2} of LCD Controller	37
B-1	Distance Between IE System and Conversion Adapter.....	41
B-2	Connection Conditions of Target System (When NP-100GC Is Used).....	42
B-3	Connection Conditions of Target System (When NP-H100GC-TQ Is Used)	42

LIST OF TABLES

Table No.	Title	Page
1-1	Correspondence Between Emulation Probes and Conversion Adapter	12
1-2	Basic Specifications	14
3-1	Main System Clock Settings.....	23
3-2	Subsystem Clock 1 Settings.....	27
3-3	Subsystem Clock 2 Settings.....	28
3-4	Jumper Settings on IE-78K0-NS	32
3-5	Jumper Settings on IE-78K0-NS-A G-780009 Board	32
3-6	Jumper Settings on IE-78K0-NS-A G-78K0H Option Board.....	32
3-7	Jumper Settings on IE-780958-NS-EM4	32
3-8	Supply Voltage and Maximum Current Consumption During Low Voltage Emulation	33
5-1	Initial Value of Port When IE System Is Started Without Target System Connected	37
5-2	Value of Vector Table Address of Watchdog Timer	37
A-1	NP-100GC, NP-H100GC-TQ Pin Assignments	39
B-1	Distance Between IE System and Conversion Adapter	41

CHAPTER 1 GENERAL

The IE-780958-NS-EM4 is a development tool for efficient debugging of hardware or software when using one of the following target devices that belong to the 78K/0 Series of 8-bit single-chip microcontrollers.

This chapter describes the system configuration and basic specifications of the IE-780958-NS-EM4.

- Target devices
 - μ PD780958 Subseries

1.1 System Configuration

Figure 1-1 illustrates the system configuration of the IE-780958-NS-EM4.

Figure 1-1. System Configuration

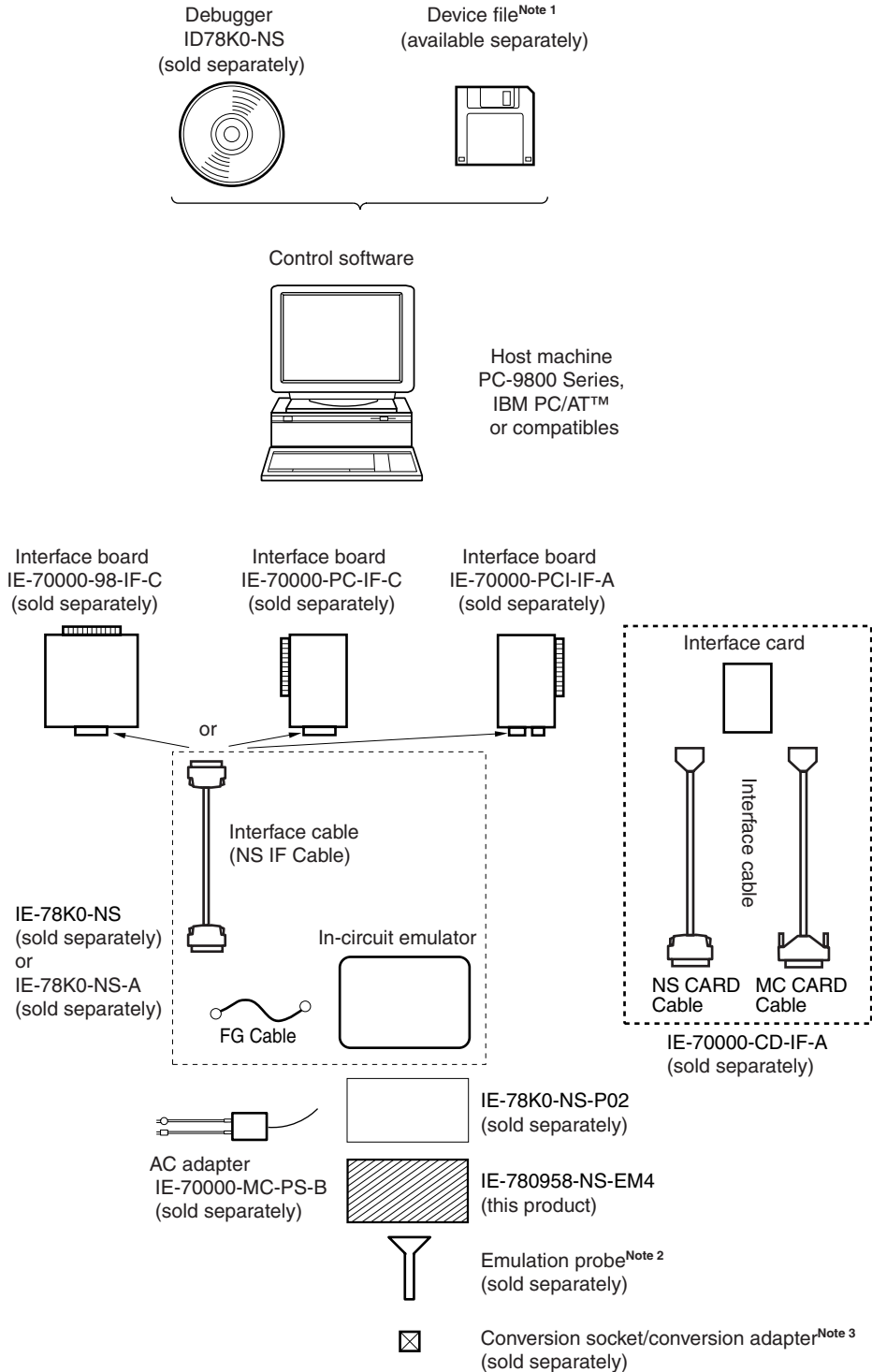

Notes 1. The device file is as follows, in accordance with the subseries.

μ SxxxxDF780958: μ PD780957(A), 780958(A)

The device file can be downloaded from the web site of NEC Electron Devices
(<http://www.ic.nec.co.jp/micro/>)

2. The emulation probes NP-100GC and NP-H100GC-TQ are products of Naito Densai Machida Mfg. Co., Ltd.

For further information, contact Naito Densai Machida Mfg. Co., Ltd. (TEL: +81-45-475-4191)

3. The conversion adapter TGC-100SDW is a product of TOKYO ELETECH CORPORATION.

For further information, contact Daimaru Kogyo Co., Ltd.

Tokyo Electronics Department (TEL: +81-3-3820-7112)

Osaka Electronics Department (TEL: +81-6-6244-6672)

The correspondence between the separately available emulation probes and conversion adapter is shown in Table 1-1.

Table 1-1. Correspondence Between Emulation Probes and Conversion Adapter

Package	Emulation Probe	Conversion Adapter
100-pin plastic LQFP	NP-100GC (probe length: 200 mm) NP-H100GC-TQ (probe length: 400 mm)	TGC-100SDW

1.2 Hardware Configuration

Figures 1-2 and 1-3 show the position of the IE-780958-NS-EM4 in the basic hardware configuration.

Figure 1-2. Basic Hardware Configuration (Using IE-78K0-NS)

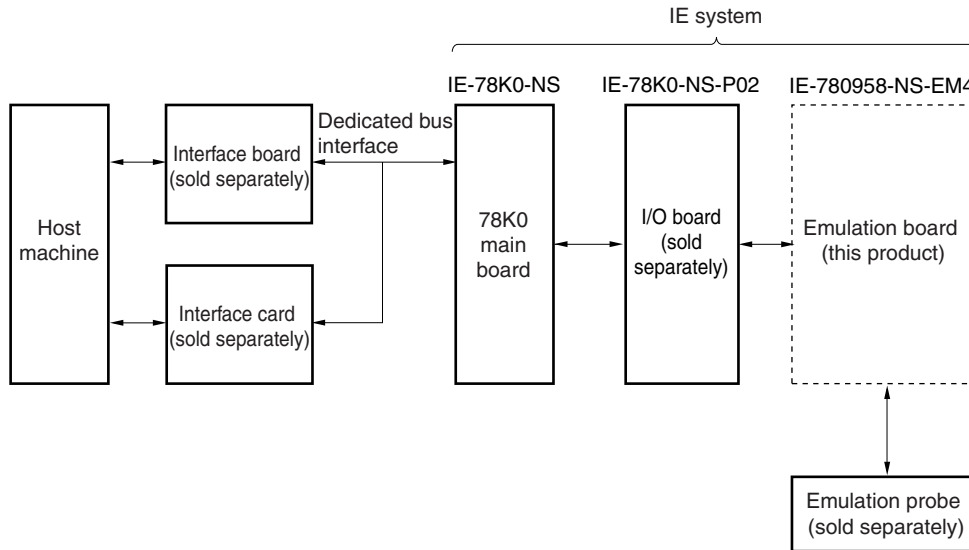
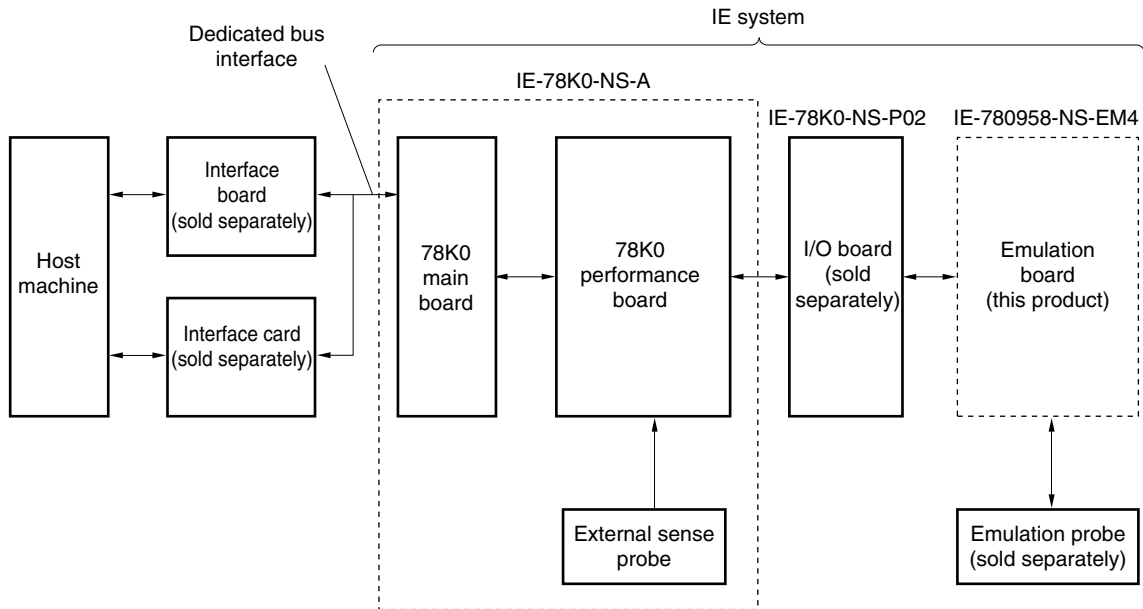

Figure 1-3. Basic Hardware Configuration (Using IE-78K0-NS-A)



1.3 Basic Specifications

The basic specifications of the IE-780958-NS-EM4 are listed in Table 1-2.

Table 1-2. Basic Specifications

Parameter	Description
Target device	μ PD780957(A), 780958(A)
System clock	1 MHz
Main system clock supply	External: Input via an emulation probe from the target system Internal: Mounted on the emulation board (1 MHz) or mounted on the board by the user
Subsystem clock supply	External: Input via an emulation probe from the target system Internal: Mounted on the emulation board (32.768 kHz) or mounted on the board by the user
Low voltage support	$V_{DD} = 2.2$ to 3.5 V (same as the target device) ^{Note}

Note When the target system is not connected, the IE system operates at 5 V. When connecting the target system, follow the settings described in 3.7 Low Voltage Emulation Setting.

CHAPTER 2 PART NAMES

This chapter introduces the parts of the IE-780958-NS-EM4 main unit.

The packing box contains the emulation board (IE-780958-NS-EM4), packing list, user's manual, and guarantee card.

If there are any missing or damaged items, please contact an NEC sales representative.

Fill out and return the guarantee card that comes with the main unit.

2.1 Parts of Main Unit

Figure 2-1. IE-780958-NS-EM4 Part Names

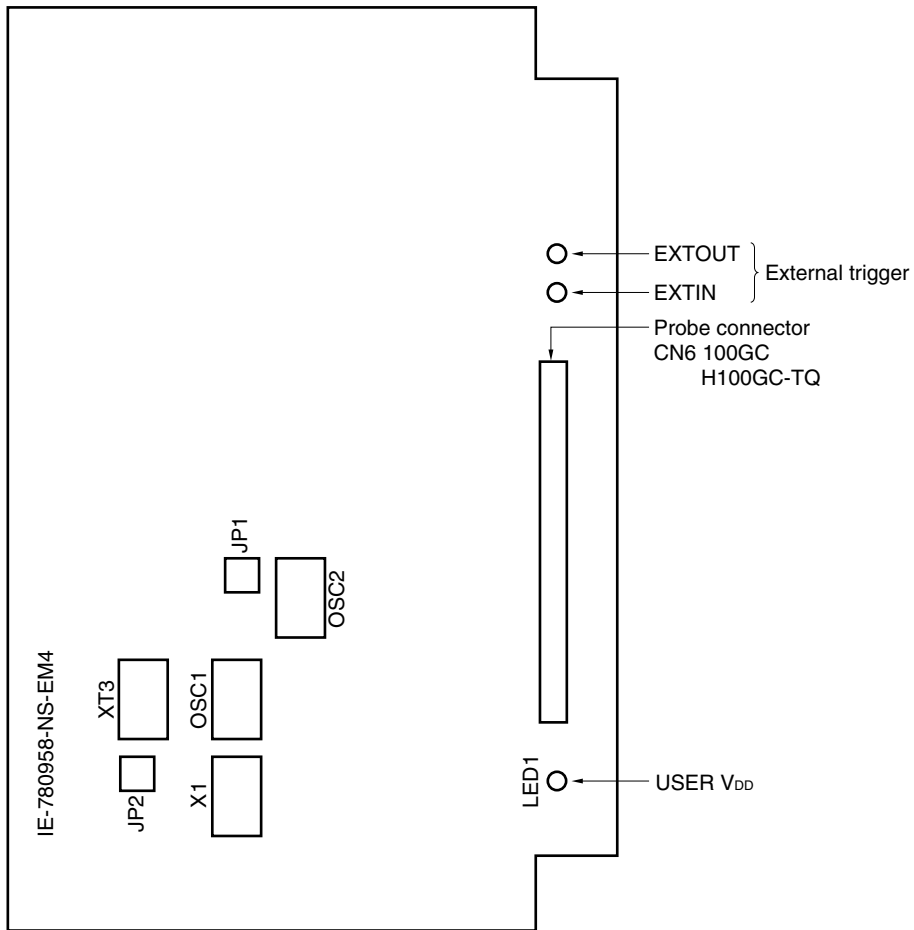

CHAPTER 3 INSTALLATION

This chapter describes methods for connecting the IE-780958-NS-EM4 to the IE-78K0-NS-P02, IE-78K0-NS or IE-78K0-NS-A, emulation probe, etc. Mode setting methods are also described.

Caution Connecting or removing components to or from the target system, or making switch or other setting changes must be carried out after the power supply to both the IE system and the target system has been switched OFF.

3.1 Connection

(1) Connection with IE-78K0-NS-P02 and IE-78K0-NS or IE-78K0-NS-A main unit

See the **IE-78K0-NS User's Manual (U13731E)** for a description of how to connect the IE-780958-NS-EM4 to the IE-78K0-NS.

See the **IE-78K0-NS-A User's Manual (U14889E)** for a description of how to connect the IE-780958-NS-EM4 to the IE-78K0-NS-A.

(2) Connection with emulation probe

See the **IE-78K0-NS User's Manual (U13731E)** or **IE-78K0-NS-A User's Manual (U14889E)** for a description of how to connect an emulation probe to the IE-780958-NS-EM4.

On this board, connect the emulation probe to CN6.

Caution Incorrect connection may damage the IE system.

Be sure to read the emulation probe user's manual for a detailed description of the connection method.

Figure 3-1. Connection of Emulation Probe

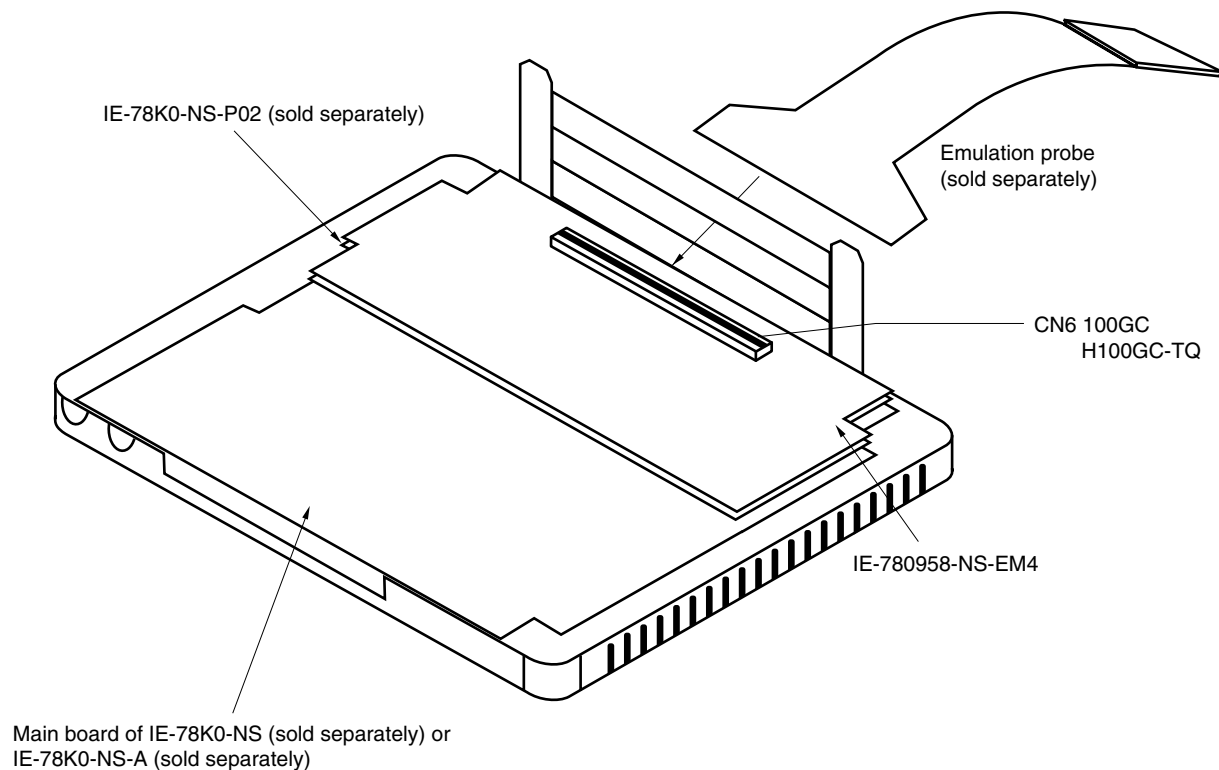

3.2 Clock Settings

3.2.1 Overview of clock settings

The main system clock and subsystem clock 2 to be used during debugging can be selected from (1) to (3) below and subsystem clock 1 can be selected from (1) and (3) below.

- (1) Clock that is already mounted on emulation board
- (2) Clock that is mounted by user
- (3) External clock

If the target system includes an internal clock, select either **(1) Clock that is already mounted on emulation board** or **(2) Clock that is mounted by user**. For an internal clock, a resonator is connected to the target device and the target device's internal oscillator is used. An example of the external circuit is shown in part (a) of Figure 3-2. During emulation, the resonator that is mounted on the target system is not used. Instead, the clock that is mounted on the emulation board connected to the IE-78K0-NS or IE-78K0-NS-A is used.

If the target system includes an external clock, select **(3) External clock**.

For an external clock, a clock signal is supplied from outside the target device and the target device's internal oscillator is not used. An example of the external circuit is shown in part (b) of Figure 3-2.

Caution The IE system will be hung-up if the main system clock is not supplied normally. Moreover, be sure to input a rectangular wave as the clock from the target. The IE system does not operate if a crystal transducer is connected to CL1 (main system clock), XT1 (subsystem clock 1), and XT3 (subsystem clock 2).

Figure 3-2. External Circuits Used as System Clock Oscillator

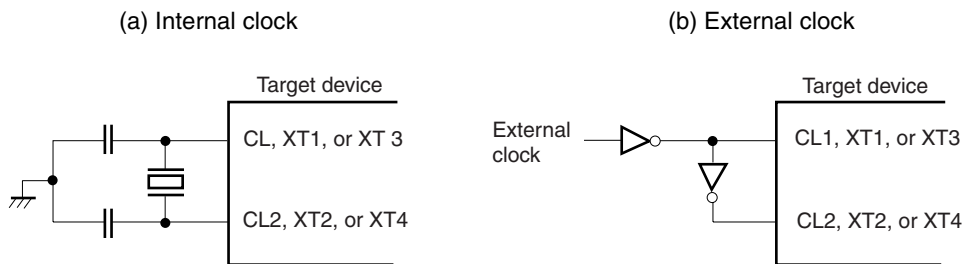

(1) Clock that is already mounted on emulation board

(a) For main system clock

A crystal oscillator (OSC1) is already mounted on the IE-780958-NS-EM4. Its frequency is 1 MHz.

Figure 3-3. When Using Clock That Is Already Mounted on Emulation Board (Main System Clock)

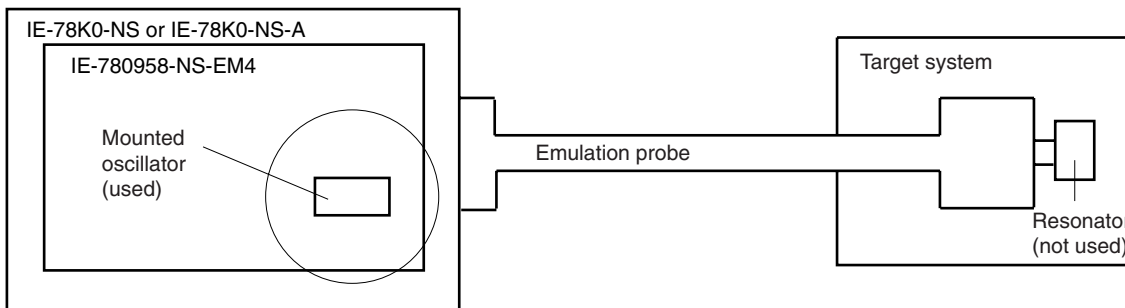

Remark The clock that is supplied by the oscillator of the IE-780958-NS-EM4 (encircled in the figure) is used.

(b) For subsystem clock 1

A crystal oscillator (OSC2) is already mounted on the IE-780958-NS-EM4. The frequency of OSC2 is 65.5360 kHz, which is divided to make 32.768 kHz in the emulator.

Figure 3-4. When Using Clock That Is Already Mounted on Emulation Board (Subsystem Clock 1)

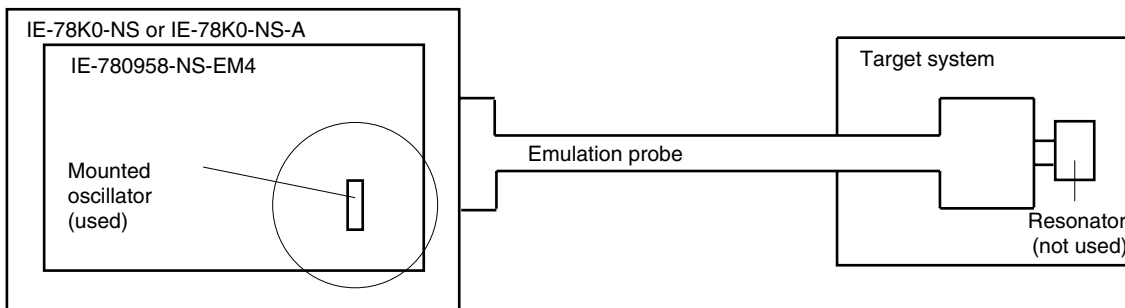

Remark The clock that is supplied by the oscillator of the IE-780958-NS-EM4 (encircled in the figure) is used.

(c) For subsystem clock 2

A crystal oscillator (XT3) is already mounted on the emulation board. Its frequency is 4.91 kHz.

Figure 3-5. When Using Clock That Is Already Mounted on Emulation Board (Subsystem Clock 2)

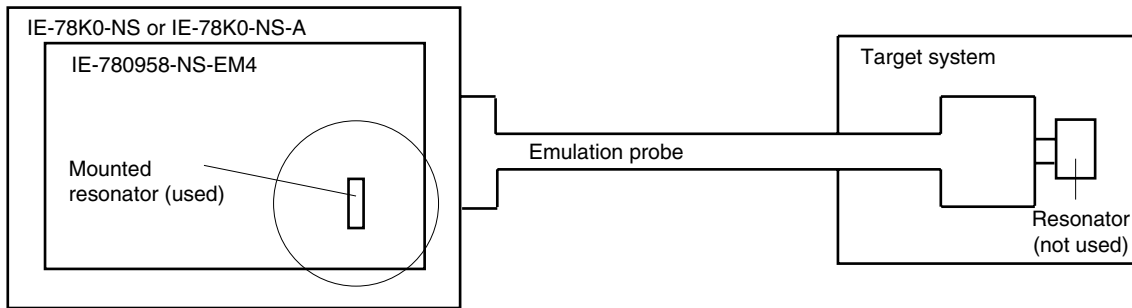

Remark The clock that is supplied by the oscillator of the IE-780958-NS-EM4 (encircled in the figure) is used.

(2) Clock that is mounted by user

The user is able to mount any clock supported by the set specifications on the IE-780958-NS-EM4.

(a) For main system clock

Remove the parts board (X1) that is already mounted on the IE-780958-NS-EM4, and mount either the parts board on which the resonator to be used is mounted or an oscillator. This method is useful when using a different frequency from that of the pre-mounted clock.

Figure 3-6. When Using User-Mounted Clock (Main System Clock)

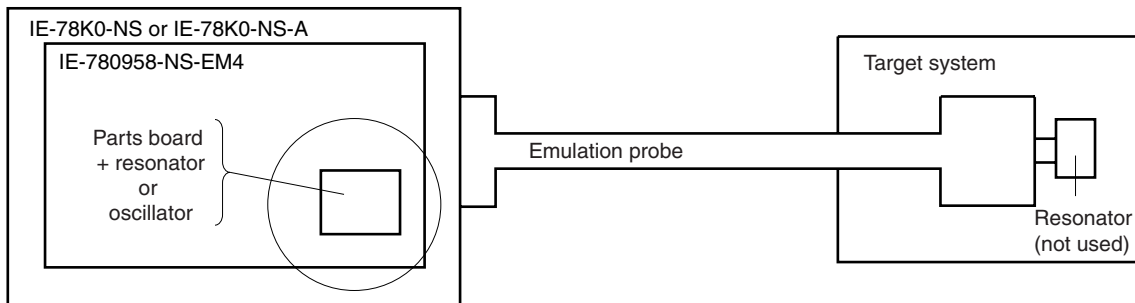

Remark The clock that is supplied by the IE-780958-NS-EM4's resonator or oscillator (encircled in the figure) is used.

(b) For subsystem clock 2

Remove the crystal oscillator (XT3) that is already mounted on the IE-780958-NS-EM4, and mount the parts board on which the resonator to be used is mounted or mount the oscillator to be used. This is useful when debugging at a frequency other than that of the clock already mounted.

Figure 3-7. When Using User-Mounted Clock (Subsystem Clock 2)

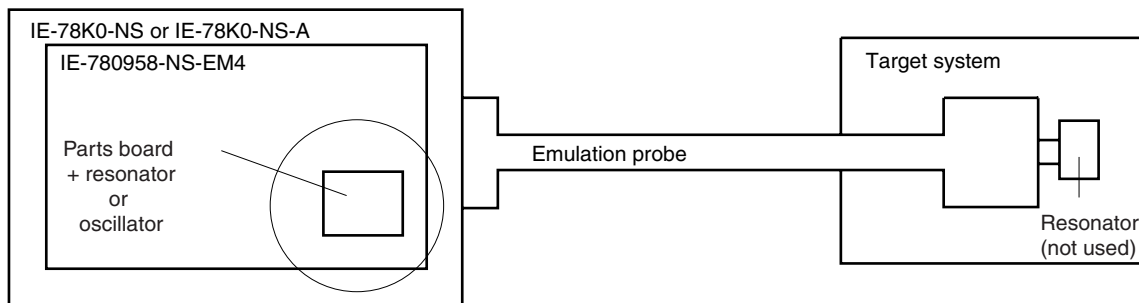

Remark The clock that is supplied by the IE-780958-NS-EM4’s resonator or oscillator (encircled in the figure) is used.

(3) External clock

An external clock connected to the target system can be used via an emulation probe.

Figure 3-8. When Using External Clock

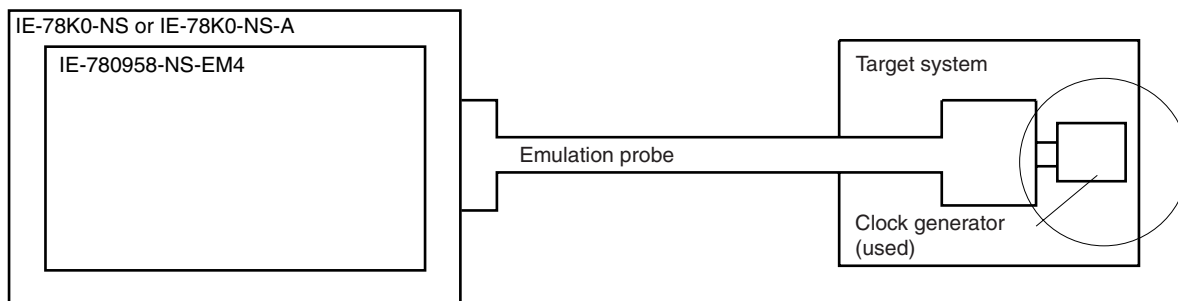

Remark The clock supplied by the target system’s clock generator (encircled in the figure) is used.

3.2.2 Main system clock settings

Table 3-1. Main System Clock Settings

Frequency of Main System Clock		IE-780958-NS-EM4	IE-78K0-NS-P02	CPU Clock Source Selection (ID78K0-NS)
		X1 Socket	X1 Socket	
When using clock that is already mounted on emulation board	1 MHz	6 and 8 shorted	Not used	Internal
When using clock mounted by user	Other than 1 MHz	Oscillator assembled by user	Not used	
When using external clock		Parts board (not used)	6 and 8 shorted	External

Caution When using an external clock, open the configuration dialog box when starting the integrated debugger (ID78K0-NS) and select “External” in the area (Clock) for selecting the CPU’s clock source (this selects the user’s clock).

Remark When the IE-780958-NS-EM4 is shipped, the settings for “when using clock that is already mounted on emulation board” are preset.

(1) When using clock that is already mounted on emulation board

When the IE-780958-NS-EM4 is shipped, a 1 MHz crystal oscillator is already mounted in OSC1 of the IE-780958-NS-EM4. When using the factory-set mode settings, there is no need to make any other hardware settings.

When starting the integrated debugger (ID78K0-NS), open the configuration dialog box and select “Internal” in the area (Clock) for selecting the CPU’s clock source (this selects the emulator’s internal clock).

(2) When using clock mounted by user

Perform the settings described under either (a) or (b), depending on the type of clock to be used. When starting the integrated debugger (ID78K0-NS), open the configuration dialog box and select "Internal" in the area (Clock) for selecting the CPU's clock source (this selects the emulator's internal clock).

(a) When using a ceramic resonator or crystal resonator

- Items to be prepared
 - Parts board
 - Ceramic resonator or crystal resonator
 - Resistor Rx
- Capacitor CA
- Capacitor CB
- Solder kit

<Steps>

<1> Solder the target ceramic resonator or crystal resonator and resistor Rx, capacitor CA, and capacitor CB (all with suitable oscillation frequencies) as shown below.

Figure 3-9. Connections on Parts Board (When Using Main System Clock or User-Mounted Clock)

Parts board (X1)

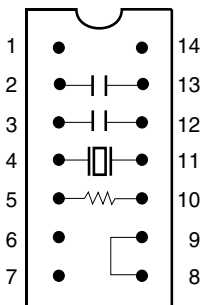

Pin No.	Connection
2-13	Capacitor CA
3-12	Capacitor CB
4-11	Ceramic resonator or crystal resonator
5-10	Resistor Rx
8-9	Shorted

Circuit diagram

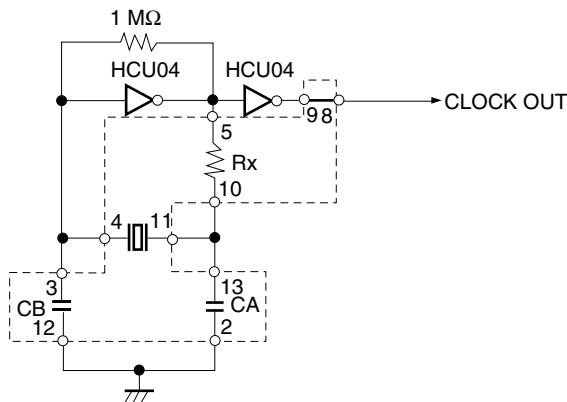

Remark The sections enclosed in broken lines indicate parts that are attached to the parts board.

- <2> Prepare the IE-780958-NS-EM4.
- <3> Remove the parts board that is mounted in the IE-780958-NS-EM4's X1 socket.
- <4> Connect the parts board (from <1> above) to the X1 socket from which the parts board was removed.
Check the pin 1 mark to make sure the board is mounted in the correct direction.
- <5> Make sure that the parts board is wired as shown in Figure 3-9 above.
- <6> Connect the IE-78K0-NS-P02 and the IE-780958-NS-EM4 to the IE-78K0-NS or IE-78K0-NS-A.

The above steps configure the following circuit and enable supply of the clock from the mounted resonator to the emulation device.

(b) When using a crystal oscillator

- Items to be prepared
 - Crystal oscillator (see pins shown in Figure 3-10)

Figure 3-10. Crystal Oscillator (When Using Main System Clock or User-Mounted Clock)

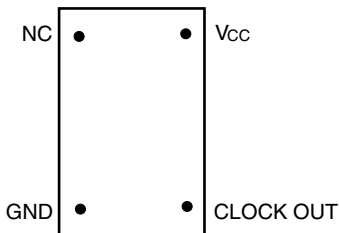

<Steps>

- <1> Prepare the IE-780958-NS-EM4.
- <2> Remove the parts board that is mounted in the IE-780958-NS-EM4's X1 socket.
- <3> Mount the crystal oscillator prepared by the user in the X1 socket from which the parts board was removed in <2> above. Insert the crystal oscillator pin into the socket aligning the pins as shown in the figure below.

Figure 3-11. Pin Alignment of Crystal Oscillator and Socket

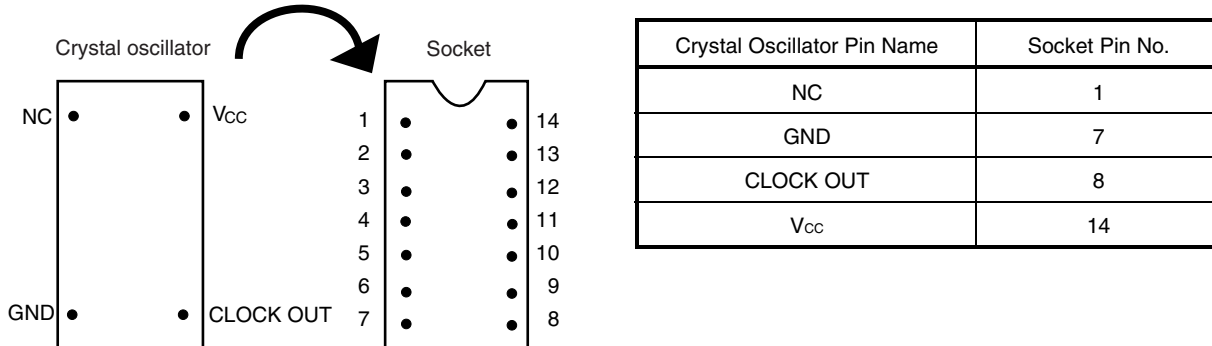

<4> Connect the IE-78K0-NS-P02 and IE-780958-NS-EM4 to the IE-78K0-NS or IE-78K0-NS-A.

The above steps configure a circuit and enable supply of the clock from the mounted resonator to the emulation device.

(3) When using external clock

Set the IE-78K0-NS-P02 to the factory settings (mount a parts board on which pins 6 and 8 are shorted in the X1 socket).

When starting the integrated debugger (ID78K0-NS), open the configuration dialog box and select “External” in the area (Clock) for selecting the CPU’s clock source (this selects the user’s clock).

3.2.3 Subsystem clock 1 settings

Table 3-2. Subsystem Clock 1 Settings

Frequency of Subsystem Clock 1 to Be Used		IE-78K0-NS-P02	IE-780958-NS-EM4
		X2 Socket	JP1
When using clock (OSC2) that is already mounted on emulation board	32.768 kHz	6 and 8 shorted	1 and 2 side shorted
When using external clock	Other than 32.768 kHz		3 and 4 side shorted

Caution Turn the power of the IE-78K0-NS or IE-78K0-NS-A off before setting JP1 to select the clock on the board or an external clock.

Remark When the IE-780958-NS-EM4 is shipped, the settings for “when using clock that is already mounted on emulation board” are preset.

(1) When using clock that is already mounted on emulation board

When the IE-780958-NS-EM4 is shipped, a 65.5360 kHz crystal resonator (OSC2) is already mounted on the IE-780958-NS-EM4 and it is divided to make 32.768 kHz. Short the 1 and 2 side on the jumper (JP1) of the IE-780958-NS-EM4. Set the IE-78K0-NS-P02 to the factory settings (mount a parts board on which pins 6 and 8 are shorted in the X2 socket). There is no need to make any other settings via the integrated debugger (ID78K0-NS).

(2) When using an external clock

Set the IE-78K0-NS-P02 to the factory settings (mount a parts board on which pins 6 and 8 are shorted in the X2 socket).

Short the 3 and 4 side on the jumper (JP1) on the IE-780958-NS-EM4.

There is no need to make any settings via the integrated debugger (ID78K0-NS).

3.2.4 Subsystem clock 2 settings

Table 3-3. Subsystem Clock 2 Settings

Frequency of Subsystem Clock 2		IE-780958-NS-EM4	
		XT3 Socket	JP2
When using clock (XT3) that is already mounted on emulation board	4.91 kHz	Oscillator	1 and 2 side shorted
When using clock mounted by user	Other than 4.91 kHz	Oscillator assembled by user	
When using external clock		Not used	3 and 4 side shorted

Caution Turn the power of the IE-78K0-NS or IE-78K0-NS-A off before setting JP2 to select the clock on the board or an external clock.

Remark When the IE-780958-NS-EM4 is shipped, the settings for “when using clock that is already mounted on emulation board” are preset.

(1) When using clock that is already mounted on emulation board

When the IE-780958-NS-EM4 is shipped, a 4.91 kHz crystal oscillator (XT3) is already mounted on the IE-780958-NS-EM4. Short the 1 and 2 side of the jumper (JP2) on the IE-780958-NS-EM4. No settings are required on the integrated debugger (ID78K0-NS).

(2) When using clock mounted by user

Perform either (a) or (b) described below, depending on the type of clock to be used. Short the 1 and 2 side of the jumper (JP2) on the IE-780958-NS-EM4.

No settings are required on the integrated debugger (ID78K0-NS).

(a) When using a ceramic resonator or crystal resonator

- Items to be prepared
 - Parts board
 - Ceramic resonator or crystal resonator
 - Resistor Rx
 - Capacitor CA
 - Capacitor CB
 - Solder kit

<Steps>

- <1> Prepare the IE-780958-NS-EM4.
- <2> Solder the target ceramic resonator or crystal resonator, resistor Rx, capacitor CA, and capacitor CB (all with suitable oscillation frequencies) to the parts board (XT3) as shown below.

Figure 3-12. Connections on Parts Board (When Using Subsystem Clock 2 or User-Mounted Clock)

Parts board (XT3)

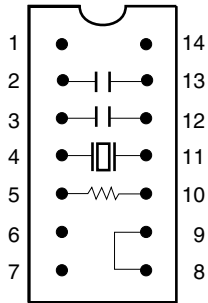

Pin No.	Connection
2-13	Capacitor CA
3-12	Capacitor CB
4-11	Ceramic resonator or crystal resonator
5-10	Resistor Rx
8-9	Shorted

Circuit diagram

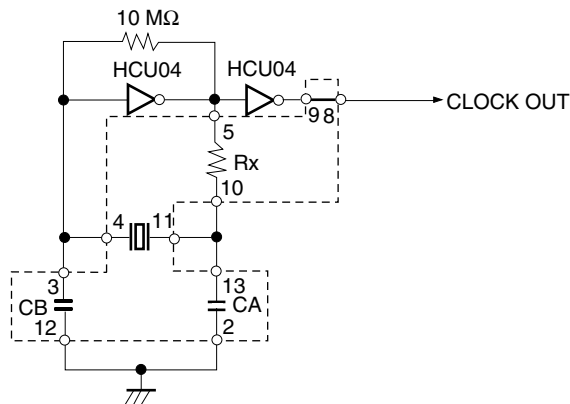

Remark The sections enclosed in broken lines indicate parts that are attached to the parts board.

- <3> Make sure that the parts board (XT3) is wired as shown in Figure 3-12 above.
- <4> Remove the crystal oscillator that is mounted in the XT3 socket of the IE-780958-NS-EM4.
- <5> Connect the parts board (<2> above) to the XT3 socket from which the crystal oscillator was removed in <4> above. Check the pin 1 mark to make sure the board is mounted in the correct direction.
- <6> Connect the IE-78K0-NS-P02 and IE-780958-NS-EM4 to the IE-78K0-NS or IE-78K0-NS-A.

(b) When using a crystal oscillator

- Items to be prepared
 - Crystal oscillator (see pins shown in Figure 3-13)

Figure 3-13. Crystal Oscillator (When Using Subsystem Clock 2 or User-Mounted Clock)

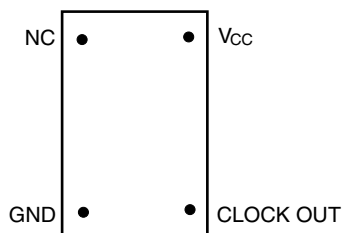

<Steps>

- <1> Prepare the IE-780958-NS-EM4.
- <2> Remove the crystal oscillator that is mounted in the XT3 socket of the IE-780958-NS-EM2.
- <3> Mount the crystal oscillator prepared by the user in the XT3 socket from which the crystal oscillator was removed in <2> above. Insert the crystal oscillator pin into the socket aligning the pins as shown in the figure below.

Figure 3-14. Pin Alignment of Crystal Oscillator and Socket

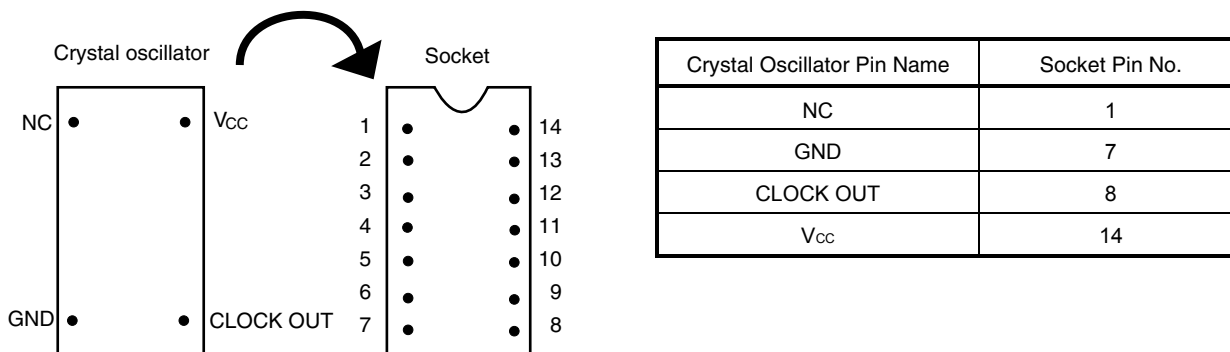

- <4> Connect the IE-78K0-NS-P02 and IE-780958-NS-EM4 to the IE-78K0-NS or IE-78K0-NS-A.

The above steps configure a circuit and enable supply of the clock from the mounted oscillator to the emulation device.

(3) When using external clock

- Short 3 and 4 of the jumper (JP2) on the IE-780958-NS-EM4.
- No settings are required on the integrated debugger (ID78K0-NS).

3.3 External Trigger

Connect the external trigger to the IE-780958-NS-EM4's check pins EXTOUT and EXTIN as shown below.

See the **ID78K Series Operation Windows Based User's Manual (U15185E)** for descriptions of related use methods, and see the **IE-78K0-NS User's Manual (U13731E)** or **IE-78K0-NS-A User's Manual (U14889E)** for pin characteristics.

Figure 3-15. External Trigger Input Position

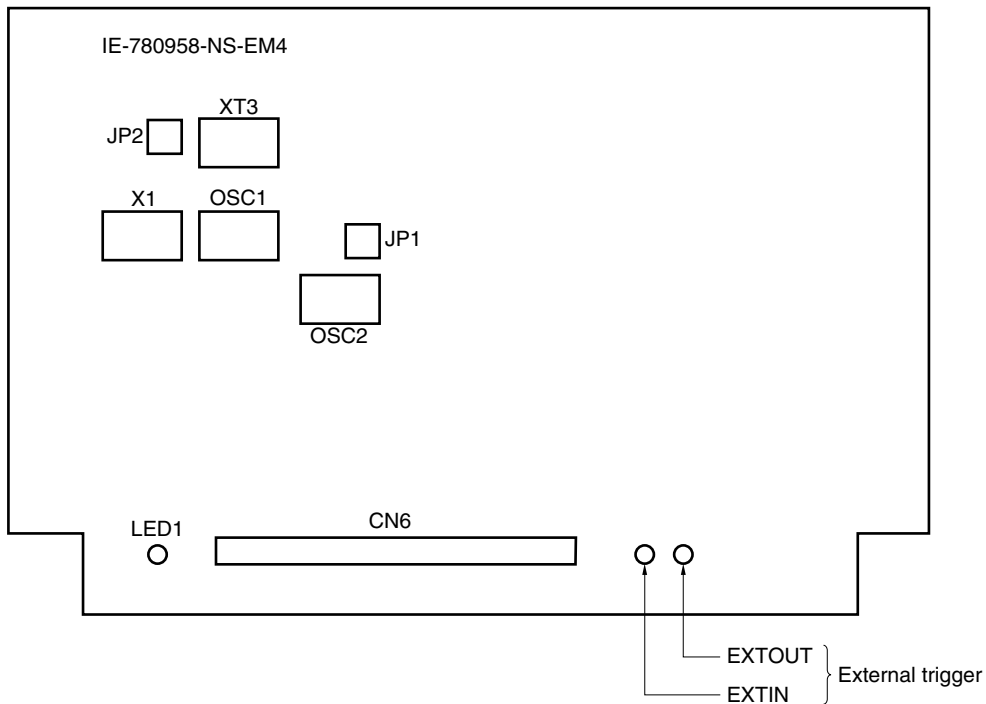

3.4 Jumper Settings on IE-78K0-NS

When using the IE-780958-NS-EM4 in combination with the IE-78K0-NS, set the jumper on the IE-78K0-NS as shown below.

For details of these jumper positions, refer to the **IE-78K0-NS User's Manual (U13731E)**.

Caution Incorrect jumper settings may damage the IE-78K0-NS.

Table 3-4. Jumper Settings on IE-78K0-NS

	JP2	JP3	JP4	JP6	JP7	JP8
Setting	2 and 3 shorted	1 and 2 shorted	1 and 2 shorted	5 and 6 shorted	1 and 2 shorted	3 and 4 shorted

3.5 Jumper Settings on IE-78K0-NS-A

When using the IE-780958-NS-EM4 in combination with the IE-78K0-NS-A, set the jumper on the IE-78K0-NS-A as shown below.

For details of these jumper positions, refer to the **IE-78K0-NS-A User's Manual (U14889E)**.

Caution Incorrect jumper settings may damage the IE-78K0-NS-A.

Table 3-5. Jumper Settings on IE-78K0-NS-A G-780009 Board

	JP2	JP3	JP4	JP6	JP7	JP8
Setting	2 and 3 shorted	1 and 2 shorted	1 and 2 shorted	5 and 6 shorted	1 and 2 shorted	3 and 4 shorted

Table 3-6. Jumper Settings on IE-78K0-NS-A G-78K0H Option Board

	JP2
Setting	2 and 3 shorted

3.6 Jumper Settings on IE-780958-NS-EM4

Set the jumpers on the IE-780958-NS-EM4 as shown below.

Caution Incorrect jumper settings may damage the IE-780958-NS-EM4.

Table 3-7. Jumper Settings on IE-780958-NS-EM4

	Setting	Description
JP1	1 and 2 shorted	OSC2 of IE-780958-NS-EM4 is used as subsystem clock 1
	3 and 4 shorted	External clock is used as subsystem clock 1
JP2	1 and 2 shorted	XT3 of IE-780958-NS-EM4 is used as subsystem clock 2
	3 and 4 shorted	External clock is used as subsystem clock 2

3.7 Low Voltage Emulation Setting

Supply the same power supply voltage as that of the target system to the TP1 terminal pin on the main board (G-780009 Board) of the IE-78K0-NS or IE-78K0-NS-A.

In this case, the power supply voltage of the target system should be in the range of 2.2 to 3.5 V.

Table 3-8. Supply Voltage and Maximum Current Consumption During Low Voltage Emulation

Supply Voltage to TP1	Maximum Current Consumption of TP1
2.2 to 3.5 V	300 mA

Figure 3-16. IE-78K0-NS or IE-78K0-NS-A Main Board (G-780009 Board)



CHAPTER 4 DIFFERENCES BETWEEN TARGET DEVICES AND TARGET INTERFACE CIRCUITS

This chapter describes differences between the target device's signal lines and the signal lines of the IE-780958-NS-EM4's target interface circuit.

Although the target device is a CMOS circuit, the IE-780958-NS-EM4's target interface circuit consists of emulation circuits such as an emulation CPU, TTL, and CMOS-IC.

When the IE system is connected with the target system for debugging, the IE system performs emulation so as to operate as the actual target device would operate in the target system.

However, some minor differences exist since the operations are performed via the IE system's emulation.

- (1) Signals input to or output from the emulation CPU (μ PD7880)
- (2) Signals input to or output from the emulation CPU (μ PD7881)
- (3) Signals input to or output from the emulation CPU (μ PD7883)
- (4) Other signals

The circuit of the IE system is used as follows for signals listed in (1) to (4) above.

(1) Signals input to or output from the emulation CPU (μ PD7880)

Refer to **Figure 4-1 Equivalent Circuit 1 of Emulation Circuit**.

- P27 to P20
- P37 to P30
- P47 to P40
- P57 to P50
- P67 to P60
- $\overline{\text{RESET}}$
- CL1, XT1

(2) Signals input to or output from the emulation CPU (μ PD7881)

Refer to **Figure 4-2 Equivalent Circuit 2 of Emulation Circuit**.

- P06 to P00

(3) Signals input to or output from the emulation CPU (μ PD7883)

Refer to **Figure 4-3 Equivalent Circuit 3 of Emulation Circuit**.

- S7 to S0
- P77 to P70
- P87 to P80
- P95 to P90
- COM2 to COM0

(4) Other signals

Refer to **Figure 4-4 Equivalent Circuit 4 of Emulation Circuit.**

- V_{DD0}, V_{DD1}
- V_{SS0}, V_{SS1}
- TEST2/TEST1
- CL2, XT2, XT4
- VR_{OUT1}, VR_{OUT2}
- V_{LC2}, V_{LC1}
- CAPH, CAPL
- XT3
- WDTOUT

Figure 4-1. Equivalent Circuit 1 of Emulation Circuit

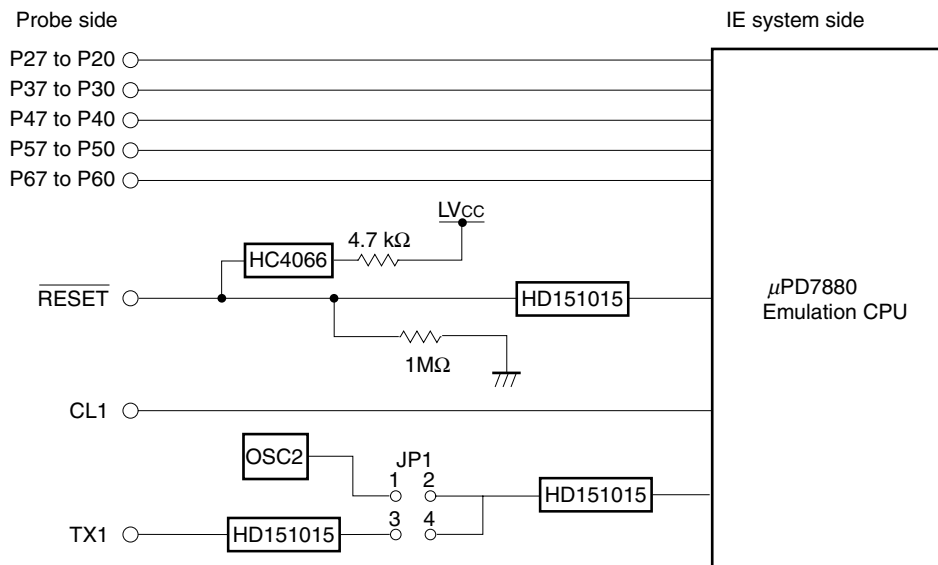

Figure 4-2. Equivalent Circuit 2 of Emulation Circuit



Figure 4-3. Equivalent Circuit 3 of Emulation Circuit

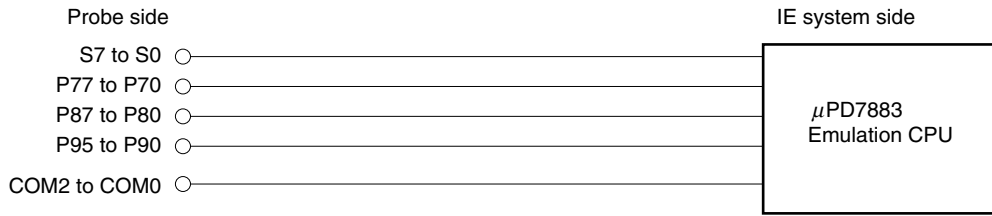
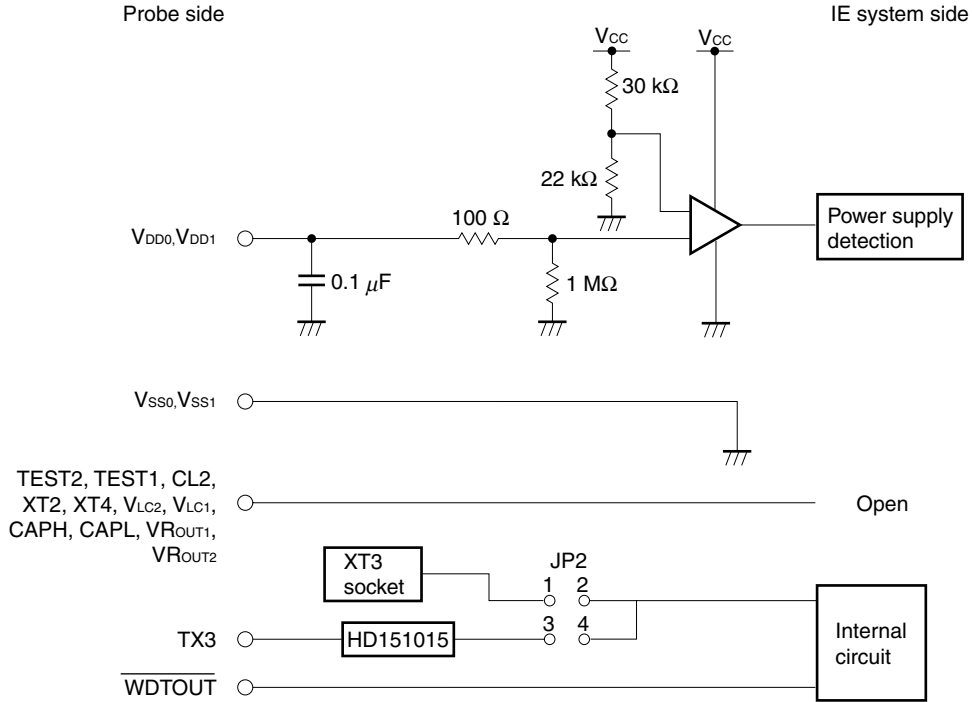

Figure 4-4. Equivalent Circuit 4 of Emulation Circuit



CHAPTER 5 RESTRICTIONS

The following are the restrictions of the IE-780958-NS-EM4.

- (1) When the IE system is started without the target system connected, the initial value of each port is undefined.

Table 5-1. Initial Value of Port When IE System Is Started Without Target System Connected

	Target Device	Emulator
Initial value of each port	00H	Undefined

- (2) The V_{LC1} and V_{LC2} pins of the LCD controller differ from those specified for the target device. The V_{LC1} and V_{LC2} pins, which are configured inside the IE system, are disconnected from the V_{LC1} and V_{LC2} pins of the target system. The V_{LC1} and V_{LC2} pins on the target system cannot be debugged.

Figure 5-1. Configuration of V_{LC1} and V_{LC2} of LCD Controller

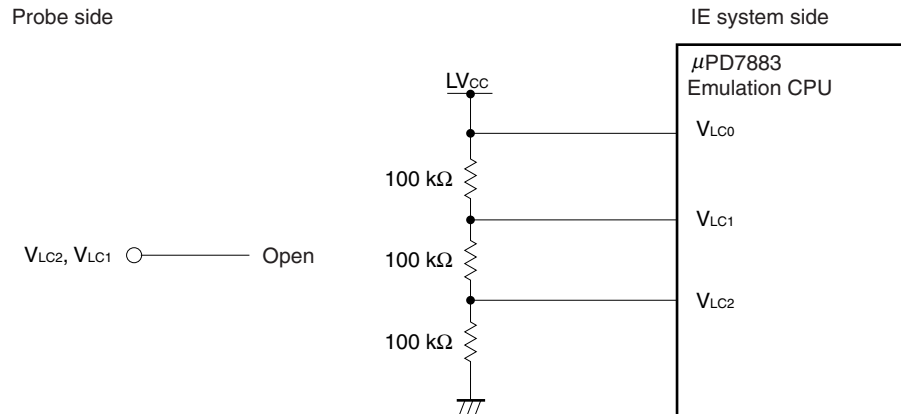

- (3) The vector table address of the watchdog timer is 02H.

Countermeasure: Write the same data to vector table addresses 02H and 04H.

Table 5-2. Value of Vector Table Address of Watchdog Timer

	Target Device	Emulator
Vector table address of watchdog timer	04H	02H

- (4) Resetting by the watchdog timer becomes valid when the target system is connected. Set the voltage to “target” in the configuration dialog box that opens when the integrated debugger is started.
- (5) When an external clock is selected as the subsystem clock, the subsystem clock (external clock) is divided by 1/2.

This does not affect the operation.

(7) Supplying the power for LCD drive cannot be emulated.

“Supply power for LCD drive (LIPS0 = 1)” is always selected regardless of the setting of LIPS of the SFR register (FF90H.4).

APPENDIX A EMULATION PROBE PIN ASSIGNMENT TABLE

Table A-1. NP-100GC, NP-H100GC-TQ Pin Assignments (1/2)

Emulation Probe	CN6 Pin No.	Emulation Probe	CN6 Pin No.
1	118	35	57
2	117	36	58
3	114	37	59
4	113	38	60
5	108	39	55
6	107	40	56
7	104	41	49
8	103	42	50
9	100	43	45
10	99	44	46
11	94	45	41
12	93	46	42
13	30	47	35
14	29	48	36
15	24	49	31
16	23	50	32
17	20	51	4
18	19	52	3
19	16	53	8
20	15	54	7
21	10	55	14
22	9	56	13
23	6	57	18
24	5	58	17
25	33	59	22
26	34	60	21
27	37	61	28
28	38	62	27
29	43	63	92
30	44	64	91
31	47	65	98
32	48	66	97
33	51	67	102
34	52	68	101

- Remarks**
1. The NP-100GC and NP-H100GC-TQ are products of Naito Densai Machida Mfg.Co., Ltd.
 2. The numbers in the “Emulation Probe” column indicate the corresponding pin number on the emulation probe tip.

Table A-1. NP-100GC, NP-H100GC-TQ Pin Assignments (2/2)

Emulation Probe	CN6 Pin No.	Emulation Probe	CN6 Pin No.
69	106	85	63
70	105	86	64
71	112	87	61
72	111	88	62
73	116	89	65
74	115	90	66
75	87	91	71
76	88	92	72
77	83	93	75
78	84	94	76
79	77	95	79
80	78	96	80
81	73	97	85
82	74	98	86
83	69	99	89
84	70	100	90

- Remarks**
1. The NP-100GC and NP-H100GC-TQ are products of Naito Densai Machida Mfg.Co., Ltd.
 2. The numbers in the “Emulation Probe” column indicate the corresponding pin number on the emulation probe tip.

APPENDIX B CAUTIONS ON DESIGNING TARGET SYSTEM

The following shows the conditions when connecting the emulation probe to the conversion adapter. Follow the configuration below and consider the shape of parts to be mounted on the target system when designing a system.

Among the products described in this appendix, NP-100GC and NP-H100GC-TQ are products of Naito Densei Machida Mfg. Co., Ltd., and TGC-100SDW is a product of TOKYO ELETECH CORPORATION.

Table B-1. Distance Between IE System and Conversion Adapter

Emulation Probe	Conversion Adapter	Distance Between IE System and Conversion Adapter
NP-100GC	TGC-100SDW	170 mm
NP-H100GC-TQ		370 mm

Figure B-1. Distance Between IE System and Conversion Adapter

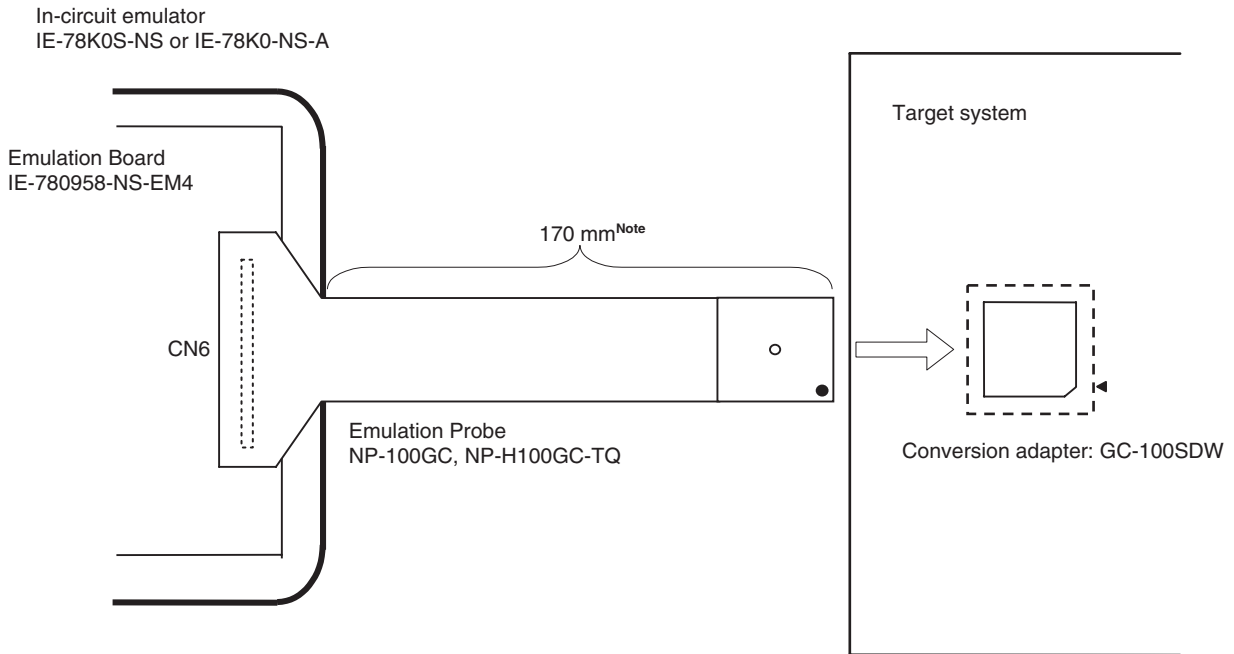

Note Distance when the NP-100GC is used. When the NP-H100GC-TQ is used, the distance is 370 mm.

Figure B-2. Connection Conditions of Target System (When NP-100GC Is Used)

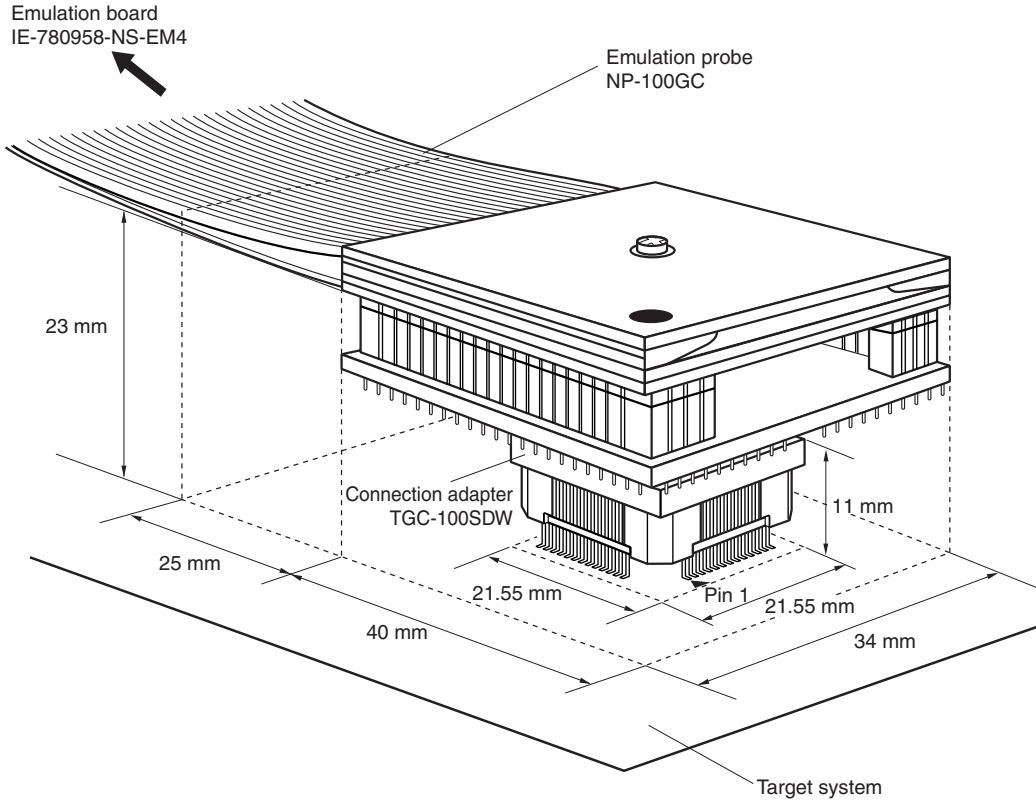
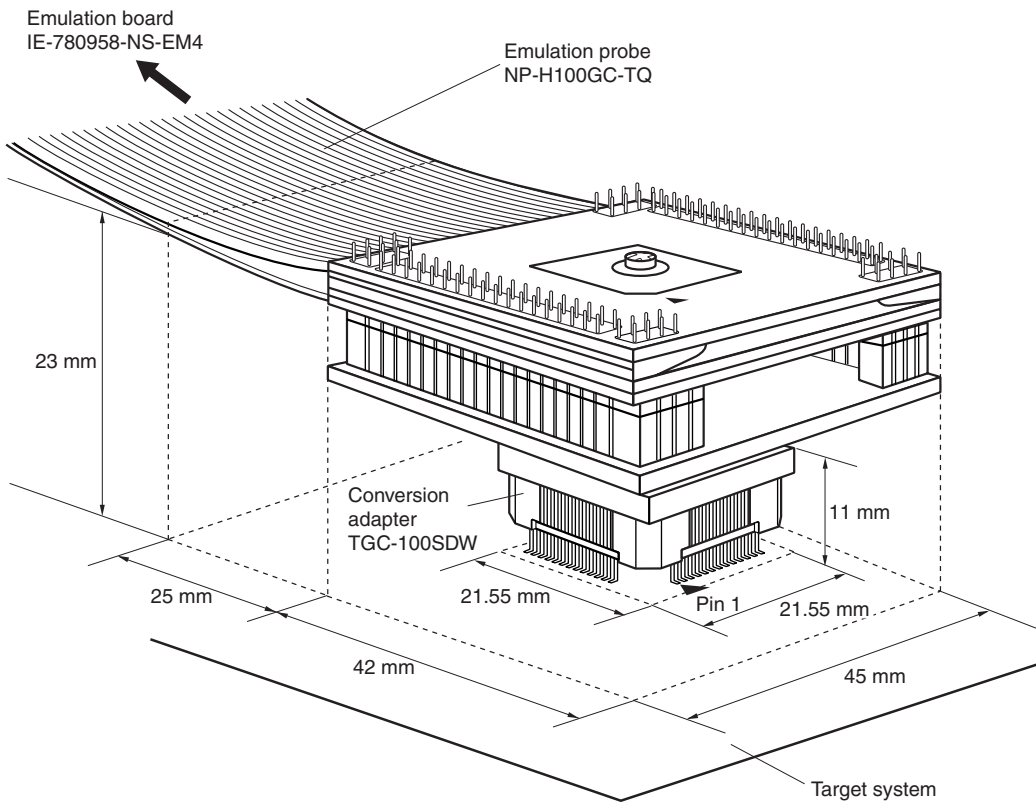

Figure B-3. Connection Conditions of Target System (When NP-H100GC-TQ Is Used)



Facsimile Message

Although NEC has taken all possible steps to ensure that the documentation supplied to our customers is complete, bug free and up-to-date, we readily accept that errors may occur. Despite all the care and precautions we've taken, you may encounter problems in the documentation. Please complete this form whenever you'd like to report errors or suggest improvements to us.

From:

Name

Company

Tel.

FAX

Address

Thank you for your kind support.

North America

NEC Electronics Inc.
Corporate Communications Dept.
Fax: +1-800-729-9288
+1-408-588-6130

Hong Kong, Philippines, Oceania

NEC Electronics Hong Kong Ltd.
Fax: +852-2886-9022/9044

Taiwan

NEC Electronics Taiwan Ltd.
Fax: +886-2-2719-5951

Europe

NEC Electronics (Europe) GmbH
Market Communication Dept.
Fax: +49-211-6503-274

Korea

NEC Electronics Hong Kong Ltd.
Seoul Branch
Fax: +82-2-528-4411

Asian Nations except Philippines

NEC Electronics Singapore Pte. Ltd.
Fax: +65-250-3583

South America

NEC do Brasil S.A.
Fax: +55-11-6462-6829

P.R. China

NEC Electronics Shanghai, Ltd.
Fax: +86-21-6841-1137

Japan

NEC Semiconductor Technical Hotline
Fax: +81- 44-435-9608

I would like to report the following error/make the following suggestion:

Document title: _____

Document number: _____ Page number: _____

If possible, please fax the referenced page or drawing.

Document Rating	Excellent	Good	Acceptable	Poor
Clarity	<input type="checkbox"/>	<input type="checkbox"/>	<input type="checkbox"/>	<input type="checkbox"/>
Technical Accuracy	<input type="checkbox"/>	<input type="checkbox"/>	<input type="checkbox"/>	<input type="checkbox"/>
Organization	<input type="checkbox"/>	<input type="checkbox"/>	<input type="checkbox"/>	<input type="checkbox"/>