

TO-252-3L

TO-220F-3L

ORDERING INFORMATION

Product	Marking	Package
SN78xxD	SN78xxD	TO-252-3L
SN78xxPI	SN78xxPI	TO-220F-3L

▲ Marking Detail Information

[TO-220F-3L & TO-253-3L PKG Marking]



- ① AUK Logo
- ② Grade & M Code & Year & Week Code
- ③ Device Code

Description

The SN78xxx series are three-terminal positive regulators providing over 1A output current with internal current limiting, thermal shutdown and safe area protection. These regulators are useful in a wide range of applications. Although they are just fixed voltage regulators, the SN78xxx series can be used with external components to obtain adjustable voltages and currents.

Application

- ◆ Consumer and personal electronics
- ◆ SMPS post-regulator / dc-to-dc modules
- ◆ High-efficiency linear power supplies

Features and Benefits

- ◆ Output Current up to 1.0A
- ◆ Output Voltage : 5, 6, 8, 9, 10, 12, 15, 18, 24V
- ◆ Built in OVP, CLP circuit.
- ◆ Built in TSD Protection.
- ◆ Output Transistor Safe Area Protection.
- ◆ Ultra High level of ESD [Built in ESD Protection Cell]

MM : 500V / HBM 5KV

Equivalent Circuit

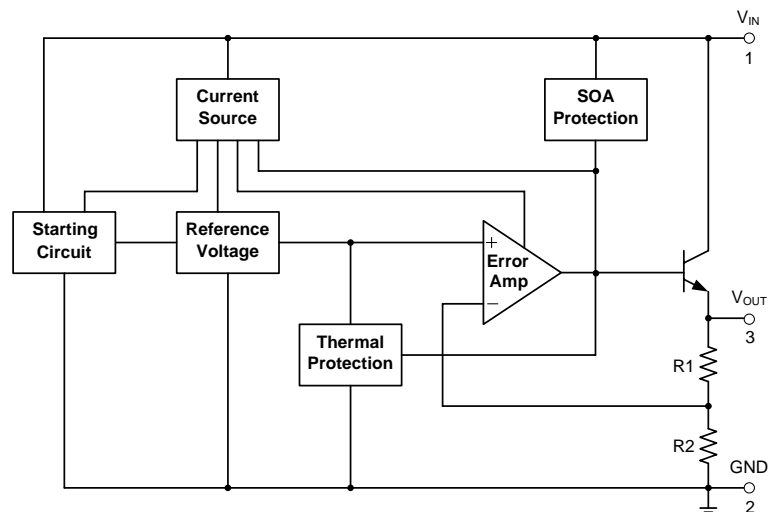

◆ Pin Configuration

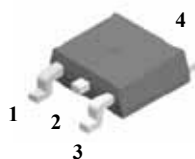

TO-252-3L

- 1: V_{IN}
- 2: GND
- 3: V_{OUT}
- 4: GND

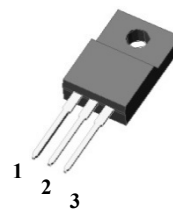

TO-220F-3L

- 1: V_{IN}
- 2: GND
- 3: V_{OUT}

◆ Product Line-up

Product Name	V_{OUT}	Operating Temperature	Package
SN7805D	5.0V	-40~125°C	TO-252-3L
SN7806D	6.0V	-40~125°C	TO-252-3L
SN7808D	8.0V	-40~125°C	TO-252-3L
SN7809D	9.0V	-40~125°C	TO-252-3L
SN7810D	10V	-40~125°C	TO-252-3L
SN7812D	12V	-40~125°C	TO-252-3L
SN7815D	15V	-40~125°C	TO-252-3L
SN7818D	18V	-40~125°C	TO-252-3L
SN7824D	24V	-40~125°C	TO-252-3L
SN7805PI	5.0V	-40~125°C	TO-220F-3L
SN7806PI	6.0V	-40~125°C	TO-220F-3L
SN7808PI	8.0V	-40~125°C	TO-220F-3L
SN7809PI	9.0V	-40~125°C	TO-220F-3L
SN7810PI	10V	-40~125°C	TO-220F-3L
SN7812PI	12V	-40~125°C	TO-220F-3L
SN7815PI	15V	-40~125°C	TO-220F-3L
SN7818PI	18V	-40~125°C	TO-220F-3L
SN7824PI	24V	-40~125°C	TO-220F-3L

◆ Absolute Maximum Ratings ($T_a = 25^\circ\text{C}$)

Parameter	Symbol	Limits		Unit
		TO-220F-3L	TO-252-3L	
Input Voltage	V_{IN}	40.0 ($V_O=24V$)		V
		35.0 ($V_O=5$ to 18V)		
Power Dissipation	P_d	2.0	1.3	W
Thermal Resistance Junction to Case	$R_{\theta JC}$	5	5	$^\circ\text{C}/\text{W}$
Thermal Resistance Junction to Air	$R_{\theta JA}$	65	92	$^\circ\text{C}/\text{W}$
Junction Temperature	T_J	150		$^\circ\text{C}$
Operate Temperature Range	T_{opr}	-40 ~ +125		$^\circ\text{C}$
Storage Temperature Range	T_{stg}	-55 ~ +150		$^\circ\text{C}$

Absolute maximum ratings indicate limits beyond which damage to the component may occur. Electrical specifications do not apply when operating the device outside of its operating ratings. The maximum allowable power dissipation is a function of the maximum junction temperature, $T_{J(max)}$, the junction-to-ambient thermal resistance, θ_{JA} , and the ambient temperature, T_A .

The maximum allowable power dissipation at any ambient temperature is calculated using:

$PD(max) = (T_{J(max)} - T_A) \div \theta_{JA}$. Exceeding the maximum allowable power dissipation will result in excessive die temperature, and the regulator will go into thermal shutdown.

◆ Electrical characteristics

($V_{IN}=10V$, $C_{IN} = 0.33\mu F$, $C_{OUT} = 0.1 \mu F$, $I_{OUT} = 500mA$, $T_J=0^{\circ}C \sim 125^{\circ}C$; unless otherwise specified)

Characteristic	Symbol	Test Condition*	SN7805x			Unit	
			Min.	Typ.	Max.		
Output Voltage**	V_O	$T_J = 25^{\circ}C$	4.80	5.00	5.20	V	
		$7.0V \leq V_{IN} \leq 20.0V$ $5.0mA \leq I_O \leq 1.0A$, $P_D \leq 15W$	4.75	5.00	5.25		
Line Regulation	$\Delta V_{O(\Delta V_I)}$	$7.0V \leq V_{IN} \leq 25.0V$	-	4.0	100	mV	
		$8.0V \leq V_{IN} \leq 12.0V$	-	1.6	50		
Load Regulation	$\Delta V_{O(\Delta I_L)}$	$5.0mA \leq I_O \leq 1.5A$	-	9.0	100	mV	
		$250mA \leq I_O \leq 750mA$	-	4.0	50		
Quiescent Current	I_{QC}	$T_J = 25^{\circ}C$	-	3.2	8.0	mA	
Quiescent Current Change	ΔI_{QC}	$7.0V \leq V_{IN} \leq 25V$	-	0.3	1.3	mA	
		$5.0mA \leq I_O \leq 1.0A$	-	0.03	0.5		
Ripple Rejection	RR	$8.0V \leq V_{IN} \leq 18.0V$ $f=120Hz$	62	73	-	dB	
Dropout Voltage	V_{DROP}	$I_O=1.0A$	$T_J = 25^{\circ}C$	-	2.0	-	V
Output Noise Voltage	V_N	$10Hz \leq f \leq 100kHz$	$T_A = 25^{\circ}C$	-	42	-	$\mu V / V_O$
Output Resistance	r_O	$f=1.0kHz$	-	15	-	$m\Omega$	
Short Circuit Current	I_{SC}	$V_I=35V$	$T_A = 25^{\circ}C$	-	250	-	mA
Peak Output Current	I_{PK}	$T_J = 25^{\circ}C$	-	2.2	-	A	
Temperature coefficient of Output voltage	$\frac{\Delta V_O}{\Delta Temp}$	$I_O=5.0mA$	-	-0.8	-	$mV/^{\circ}C$	

* Pulse testing techniques are used to maintain the junction temperature as close to the ambient temperature as possible. Thermal effects must be taken into separately.

** This specification applies only for dc power dissipation permitted by absolute maximum ratings.

◆ Electrical characteristics

($V_{IN}=11V$, $C_{IN} = 0.33\mu F$, $C_{OUT} = 0.1 \mu F$, $I_{OUT} = 500mA$, $T_J=0^\circ C \sim 125^\circ C$; unless otherwise specified)

Characteristic	Symbol	Test Condition*	SN7806x			Unit
			Min.	Typ.	Max.	
Output Voltage**	V_O	$T_J = 25^\circ C$	5.75	6.00	6.25	V
		$8.0V \leq V_{IN} \leq 21V$ $5.0mA \leq I_O \leq 1.0A$, $P_D \leq 15W$	5.70	6.00	6.30	
Line Regulation	$\Delta V_{O(\Delta V_I)}$	$8.0V \leq V_{IN} \leq 25.0V$	-	5.0	120	mV
		$9.0V \leq V_{IN} \leq 13.0V$	-	1.5	60	
Load Regulation	$\Delta V_{O(\Delta I_L)}$	$5.0mA \leq I_O \leq 1.5A$	-	9.0	120	mV
		$250mA \leq I_O \leq 750mA$	-	3.0	60	
Quiescent Current	I_{QC}	$T_J = 25^\circ C$	-	5.0	8.0	mA
Quiescent Current Change	ΔI_{QC}	$8.0V \leq V_{IN} \leq 25.0V$	-	-	1.3	mA
		$5.0mA \leq I_O \leq 1.0A$	-	-	0.5	
Ripple Rejection	RR	$9.0V \leq V_{IN} \leq 19.0V$ $f=120Hz$	59	75	-	dB
Dropout Voltage	V_{DROP}	$I_O=1.0A$	-	2.0	-	V
Output Noise Voltage	V_N	$10Hz \leq f \leq 100kHz$	-	45	-	$\mu V / V_O$
Output Resistance	r_O	$f=1.0kHz$	-	19	-	$m\Omega$
Short Circuit Current	I_{SC}	$V_I=35V$	-	250	-	mA
Peak Output Current	I_{PK}	$T_J = 25^\circ C$	-	2.2	-	A
Temperature coefficient of Output voltage	$\frac{\Delta V_O}{\Delta Temp}$	$I_O=5.0mA$	-	-0.8	-	$mV/^\circ C$

* Pulse testing techniques are used to maintain the junction temperature as close to the ambient temperature as possible. Thermal effects must be taken into separately.

** This specification applies only for dc power dissipation permitted by absolute maximum ratings.

◆ Electrical characteristics

($V_{IN}=14V$, $C_{IN} = 0.33\mu F$, $C_{OUT} = 0.1 \mu F$, $I_{OUT} = 500mA$, $T_J=0^\circ C \sim 125^\circ C$; unless otherwise specified)

Characteristic	Symbol	Test Condition*	SN7808x			Unit
			Min.	Typ.	Max.	
Output Voltage**	V_O	$T_J = 25^\circ C$	7.70	8.00	8.30	V
		$10.5V \leq V_{IN} \leq 23.0V$ $5.0mA \leq I_O \leq 1.0A$, $P_D \leq 15W$	7.60	8.00	8.40	
Line Regulation	$\Delta V_{O(\Delta V_I)}$	$10.5V \leq V_{IN} \leq 25.0V$	-	5.0	160	mV
		$11.5V \leq V_{IN} \leq 17.0V$	-	2.0	80	
Load Regulation	$\Delta V_{O(\Delta I_L)}$	$5.0mA \leq I_O \leq 1.5A$	-	10.0	160	mV
		$250mA \leq I_O \leq 750mA$	-	5.0	80	
Quiescent Current	I_{QC}	$T_J = 25^\circ C$	-	5.0	8.0	mA
Quiescent Current Change	ΔI_{QC}	$10.5V \leq V_{IN} \leq 25.0V$	-	0.5	1.0	mA
		$5.0mA \leq I_O \leq 1.0A$	-	0.05	0.5	
Ripple Rejection	RR	$11.5V \leq V_{IN} \leq 21.5V$ $f=120Hz$	56	73	-	dB
Dropout Voltage	V_{DROP}	$I_O=1.0A$	-	2.0	-	V
Output Noise Voltage	V_N	$10Hz \leq f \leq 100kHz$	-	52	-	$\mu V / V_O$
Output Resistance	r_O	$f=1.0kHz$	-	17	-	$m\Omega$
Short Circuit Current	I_{SC}	$V_I=35V$,	-	250	-	mA
Peak Output Current	I_{PK}	$T_J = 25^\circ C$	-	2.2	-	A
Temperature coefficient of Output voltage	$\frac{\Delta V_O}{\Delta Temp}$	$I_O=5.0mA$	-	-0.8	-	$mV/^\circ C$

* Pulse testing techniques are used to maintain the junction temperature as close to the ambient temperature as possible. Thermal effects must be taken into separately.

** This specification applies only for dc power dissipation permitted by absolute maximum ratings.

◆ Electrical characteristics

($V_{IN}=15V$, $C_{IN} = 0.33\mu F$, $C_{OUT} = 0.1 \mu F$, $I_{OUT} = 500mA$, $T_J=0^\circ C \sim 125^\circ C$; unless otherwise specified)

Characteristic	Symbol	Test Condition*	SN7809x			Unit
			Min.	Typ.	Max.	
Output Voltage**	V_O	$T_J = 25^\circ C$	8.65	9.00	9.35	V
		$11.5V \leq V_{IN} \leq 24.0V$ $5.0mA \leq I_O \leq 1.0A$, $P_D \leq 15W$	8.60	9.00	9.40	
Line Regulation	$\Delta V_{O(\Delta V_I)}$	$11.5V \leq V_{IN} \leq 25.0V$	-	6.0	180	mV
		$12.0V \leq V_{IN} \leq 17.0V$	-	2.0	90	
Load Regulation	$\Delta V_{O(\Delta I_L)}$	$5.0mA \leq I_O \leq 1.5A$	-	12.0	180	mV
		$250mA \leq I_O \leq 750mA$	-	4.0	90	
Quiescent Current	I_{QC}	$T_J = 25^\circ C$	-	5.0	8.0	mA
Quiescent Current Change	ΔI_{QC}	$11.5V \leq V_{IN} \leq 26.0V$	-	-	1.3	mA
		$5.0mA \leq I_O \leq 1.0A$	-	-	0.5	
Ripple Rejection	RR	$12.0V \leq V_{IN} \leq 22.0V$ $f=120Hz$	56	71	-	dB
Dropout Voltage	V_{DROP}	$I_O=1.0A$	-	2.0	-	V
Output Noise Voltage	V_N	$10Hz \leq f \leq 100kHz$	-	58	-	$\mu V / V_O$
Output Resistance	r_O	$f=1.0kHz$	-	17	-	$m\Omega$
Short Circuit Current	I_{SC}	$V_I=35V$	-	250	-	mA
Peak Output Current	I_{PK}	$T_J = 25^\circ C$	-	2.2	-	A
Temperature coefficient of Output voltage	$\frac{\Delta V_O}{\Delta Temp}$	$I_O=5.0mA$	-	-1.0	-	$mV/^\circ C$

* Pulse testing techniques are used to maintain the junction temperature as close to the ambient temperature as possible. Thermal effects must be taken into separately.

** This specification applies only for dc power dissipation permitted by absolute maximum ratings.

◆ Electrical characteristics

($V_{IN}=16V$, $C_{IN} = 0.33\mu F$, $C_{OUT} = 0.1 \mu F$, $I_{OUT} = 500mA$, $T_J=0^\circ C \sim 125^\circ C$; unless otherwise specified)

Characteristic	Symbol	Test Condition*	SN7810x			Unit
			Min.	Typ.	Max.	
Output Voltage**	V_O	$T_J = 25^\circ C$	9.60	10.00	10.40	V
		$12.5V \leq V_{IN} \leq 25.0V$ $5.0mA \leq I_O \leq 1.0A$, $P_D \leq 15W$	9.50	10.00	10.50	
Line Regulation	$\Delta V_{O(\Delta V_I)}$	$12.5V \leq V_{IN} \leq 25.0V$	-	10.0	200	mV
		$13.0V \leq V_{IN} \leq 18.0V$	-	3.0	100	
Load Regulation	$\Delta V_{O(\Delta I_L)}$	$5.0mA \leq I_O \leq 1.5A$	-	12.0	200	mV
		$250mA \leq I_O \leq 750mA$	-	4.0	100	
Quiescent Current	I_{QC}	$T_J = 25^\circ C$	-	5.1	8.0	mA
Quiescent Current Change	ΔI_{QC}	$12.5V \leq V_{IN} \leq 29V$	-	-	1.0	mA
		$5.0mA \leq I_O \leq 1.0A$	-	-	0.5	
Ripple Rejection	RR	$13.0V \leq V_{IN} \leq 23.0V$ $f=120Hz$	56	71	-	dB
Dropout Voltage	V_{DROP}	$I_O=1.0A$	-	2.0	-	V
Output Noise Voltage	V_N	$10Hz \leq f \leq 100kHz$	-	58	-	$\mu V / V_O$
Output Resistance	r_O	$f=1.0kHz$	-	17	-	$m\Omega$
Short Circuit Current	I_{SC}	$V_I=35V$,	-	250	-	mA
Peak Output Current	I_{PK}	$T_J = 25^\circ C$	-	2.2	-	A
Temperature coefficient of Output voltage	$\frac{\Delta V_O}{\Delta Temp}$	$I_O=5.0mA$	-	-1.0	-	$mV/^\circ C$

* Pulse testing techniques are used to maintain the junction temperature as close to the ambient temperature as possible. Thermal effects must be taken into separately.

** This specification applies only for dc power dissipation permitted by absolute maximum ratings.

◆ Electrical characteristics

($V_{IN}=19V$, $C_{IN} = 0.33\mu F$, $C_{OUT} = 0.1 \mu F$, $I_{OUT} = 500mA$, $T_J=0^\circ C \sim 125^\circ C$; unless otherwise specified)

Characteristic	Symbol	Test Condition*	SN7812x			Unit
			Min.	Typ.	Max.	
Output Voltage**	V_O	$T_J = 25^\circ C$	11.50	12.00	12.50	V
		$14.5V \leq V_{IN} \leq 27.0V$ $5.0mA \leq I_O \leq 1.0A$, $P_D \leq 15W$	11.40	12.00	12.60	
Line Regulation	$\Delta V_{O(\Delta V_I)}$	$14.5V \leq V_{IN} \leq 30.0V$	-	10.0	240	mV
		$16.0V \leq V_{IN} \leq 22.0V$	-	3.0	120	
Load Regulation	$\Delta V_{O(\Delta I_L)}$	$5.0mA \leq I_O \leq 1.5A$	-	11.0	240	mV
		$250mA \leq I_O \leq 750mA$	-	5.0	120	
Quiescent Current	I_{QC}	$T_J = 25^\circ C$	-	5.1	8.0	mA
Quiescent Current Change	ΔI_{QC}	$14.5V \leq V_{IN} \leq 30.0V$	-	0.5	1.0	mA
		$5.0mA \leq I_O \leq 1.0A$	-	0.1	0.5	
Ripple Rejection	RR	$15.0V \leq V_{IN} \leq 25.0V$ $f=120Hz$	55	71	-	dB
Dropout Voltage	V_{DROP}	$I_O=1.0A$	-	2.0	-	V
Output Noise Voltage	V_N	$10Hz \leq f \leq 100kHz$	-	76	-	$\mu V / V_O$
Output Resistance	r_O	$f=1.0kHz$	-	15	-	$m\Omega$
Short Circuit Current	I_{SC}	$V_I=35V$	-	250	-	mA
Peak Output Current	I_{PK}	$T_J = 25^\circ C$	-	2.2	-	A
Temperature coefficient of Output voltage	$\frac{\Delta V_O}{\Delta Temp}$	$I_O=5.0mA$	-	-1.0	-	$mV/^\circ C$

* Pulse testing techniques are used to maintain the junction temperature as close to the ambient temperature as possible. Thermal effects must be taken into separately.

** This specification applies only for dc power dissipation permitted by absolute maximum ratings.

◆ Electrical characteristics

($V_{IN}=23V$, $C_{IN} = 0.33\mu F$, $C_{OUT} = 0.1 \mu F$, $I_{OUT} = 500mA$, $T_J=0^{\circ}C \sim 125^{\circ}C$; unless otherwise specified)

Characteristic	Symbol	Test Condition*	SN7815x			Unit	
			Min.	Typ.	Max.		
Output Voltage**	V_O	$T_J = 25^{\circ}C$	14.40	15.00	15.60	V	
		$17.5V \leq V_{IN} \leq 30.0V$ $5.0mA \leq I_O \leq 1.0A$, $P_D \leq 15W$	14.25	15.00	15.75		
Line Regulation	$\Delta V_{O(\Delta V_I)}$	$17.5V \leq V_{IN} \leq 30.0V$	-	11.0	300	mV	
		$20.0V \leq V_{IN} \leq 26.0V$	-	3.0	150		
Load Regulation	$\Delta V_{O(\Delta I_L)}$	$5.0mA \leq I_O \leq 1.5A$	-	12.0	300	mV	
		$250mA \leq I_O \leq 750mA$	-	4.0	150		
Quiescent Current	I_{QC}	$T_J = 25^{\circ}C$	-	5.2	8.0	mA	
Quiescent Current Change	ΔI_{QC}	$17.5V \leq V_{IN} \leq 30.0V$	-	-	1.0	mA	
		$5.0mA \leq I_O \leq 1.0A$	-	-	0.5		
Ripple Rejection	RR	$18.5V \leq V_{IN} \leq 28.5V$ $f=120Hz$	54	70	-	dB	
Dropout Voltage	V_{DROP}	$I_O=1.0A$	$T_J = 25^{\circ}C$	-	2.0	-	V
Output Noise Voltage	V_N	$10Hz \leq f \leq 100kHz$	$T_A = 25^{\circ}C$	-	90	-	$\mu V / V_O$
Output Resistance	r_O	$f=1.0kHz$	-	19	-	$m\Omega$	
Short Circuit Current	I_{SC}	$V_I=35V$	$T_A = 25^{\circ}C$	-	250	-	mA
Peak Output Current	I_{PK}	$T_J = 25^{\circ}C$	-	2.2	-	A	
Temperature coefficient of Output voltage	$\frac{\Delta V_O}{\Delta Temp}$	$I_O=5.0mA$	-	-1.0	-	$mV/^{\circ}C$	

* Pulse testing techniques are used to maintain the junction temperature as close to the ambient temperature as possible. Thermal effects must be taken into separately.

** This specification applies only for dc power dissipation permitted by absolute maximum ratings.

◆ Electrical characteristics

($V_{IN}=27V$, $C_{IN} = 0.33\mu F$, $C_{OUT} = 0.1 \mu F$, $I_{OUT} = 500mA$, $T_J=0^\circ C \sim 125^\circ C$; unless otherwise specified)

Characteristic	Symbol	Test Condition*	SN7818x			Unit	
			Min.	Typ.	Max.		
Output Voltage**	V_O	$T_J = 25^\circ C$	17.30	18.00	18.70	V	
		$21.0V \leq V_{IN} \leq 33.0V$ $5.0mA \leq I_O \leq 1.0A$, $P_D \leq 15W$	17.10	18.00	18.90		
Line Regulation	$\Delta V_{O(\Delta V_I)}$	$21.0V \leq V_{IN} \leq 33.0V$	-	15.0	360	mV	
		$24.0V \leq V_{IN} \leq 30.0V$	-	5.0	180		
Load Regulation	$\Delta V_{O(\Delta I_L)}$	$5.0mA \leq I_O \leq 1.5A$	-	15.0	360	mV	
		$250mA \leq I_O \leq 750mA$	-	5.0	180		
Quiescent Current	I_{QC}	$T_J = 25^\circ C$	-	5.2	8.0	mA	
Quiescent Current Change	ΔI_{QC}	$21.0V \leq V_{IN} \leq 33.0V$	-	-	1.0	mA	
		$5.0mA \leq I_O \leq 1.0A$	-	-	0.5		
Ripple Rejection	RR	$22.0V \leq V_{IN} \leq 32.0V$ $f=120Hz$	53	69	-	dB	
Dropout Voltage	V_{DROP}	$I_O=1.0A$	$T_J = 25^\circ C$	-	2.0	-	V
Output Noise Voltage	V_N	$10Hz \leq f \leq 100kHz$	$T_A = 25^\circ C$	-	110	-	$\mu V / V_O$
Output Resistance	r_O	$f=1.0kHz$	-	22	-	$m\Omega$	
Short Circuit Current	I_{SC}	$V_I=35V$	$T_A = 25^\circ C$	-	250	-	mA
Peak Output Current	I_{PK}	$T_J = 25^\circ C$	-	2.2	-	A	
Temperature coefficient of Output voltage	$\frac{\Delta V_O}{\Delta Temp}$	$I_O=5.0mA$	-	-1.0	-	$mV/^\circ C$	

* Pulse testing techniques are used to maintain the junction temperature as close to the ambient temperature as possible. Thermal effects must be taken into separately.

** This specification applies only for dc power dissipation permitted by absolute maximum ratings.

◆ Electrical characteristics

($V_{IN}=33V$, $C_{IN} = 0.33\mu F$, $C_{OUT} = 0.1 \mu F$, $I_{OUT} = 500mA$, $T_J=0^\circ C \sim 125^\circ C$; unless otherwise specified)

Characteristic	Symbol	Test Condition*	SN7824x			Unit	
			Min.	Typ.	Max.		
Output Voltage**	V_O	$T_J = 25^\circ C$	23.00	24.00	25.00	V	
		$27.0V \leq V_{IN} \leq 38.0V$ $5.0mA \leq I_O \leq 1.0A$, $P_D \leq 15W$	22.80	24.00	25.25		
Line Regulation	$\Delta V_{O(\Delta V_I)}$	$27.0V \leq V_{IN} \leq 38.0V$	-	17.0	480	mV	
		$30.0V \leq V_{IN} \leq 36.0V$	-	6.0	240		
Load Regulation	$\Delta V_{O(\Delta I_L)}$	$5.0mA \leq I_O \leq 1.5A$	-	15.0	480	mV	
		$250mA \leq I_O \leq 750mA$	-	5.0	240		
Quiescent Current	I_{QC}	$T_J = 25^\circ C$	-	5.2	8.0	mA	
Quiescent Current Change	ΔI_{QC}	$27.0V \leq V_{IN} \leq 38.0V$	-	0.5	1.0	mA	
		$5.0mA \leq I_O \leq 1.0A$	-	0.1	0.5		
Ripple Rejection	RR	$28.0V \leq V_{IN} \leq 38.0V$ $f=120Hz$	50	67	-	dB	
Dropout Voltage	V_{DROP}	$I_O=1.0A$	$T_J = 25^\circ C$	-	2.0	-	V
Output Noise Voltage	V_N	$10Hz \leq f \leq 100kHz$	$T_A = 25^\circ C$	-	60	-	$\mu V / V_O$
Output Resistance	r_O	$f=1.0kHz$	-	28	-	$m\Omega$	
Short Circuit Current	I_{SC}	$V_I=35V$	$T_A = 25^\circ C$	-	250	-	mA
Peak Output Current	I_{PK}	$T_J = 25^\circ C$	-	2.2	-	A	
Temperature coefficient of Output voltage	$\frac{\Delta V_O}{\Delta Temp}$	$I_O=5.0mA$	-	-1.5	-	$mV/^\circ C$	

* Pulse testing techniques are used to maintain the junction temperature as close to the ambient temperature as possible. Thermal effects must be taken into separately.

** This specification applies only for dc power dissipation permitted by absolute maximum ratings.

Typical Application

Fixed Output Regulator

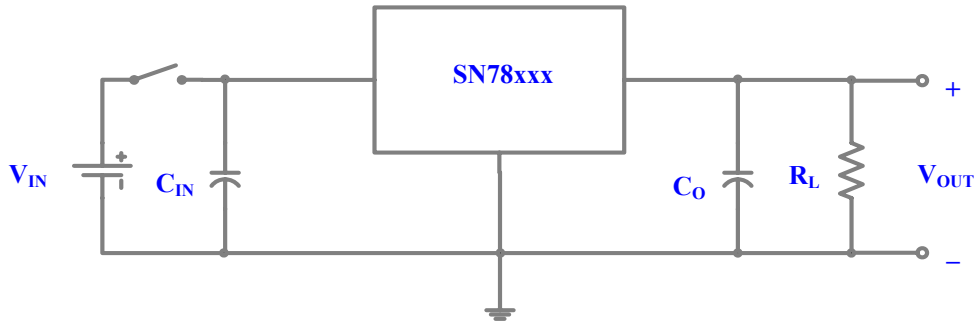

- 1) C_{IN} should be required if regulators are located far from power supply filter
- 2) C_O improves output stability and transient response

Load Regulation

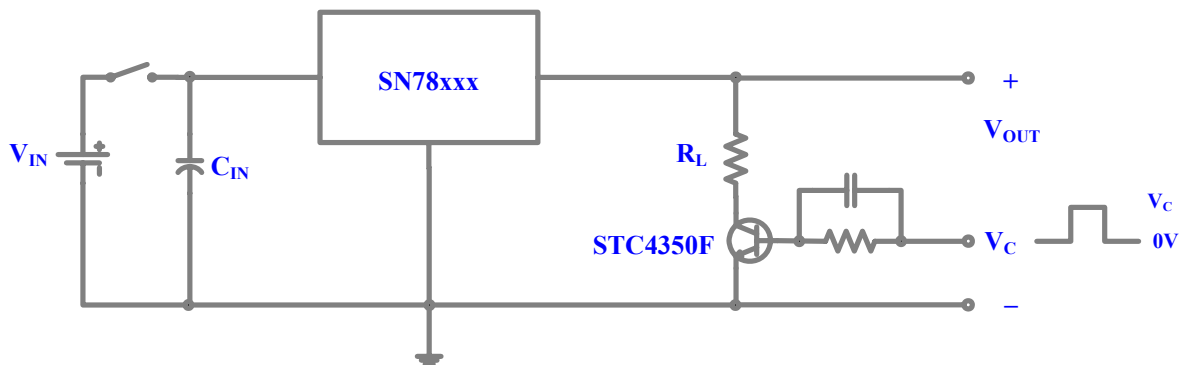

Constant Current Regulator

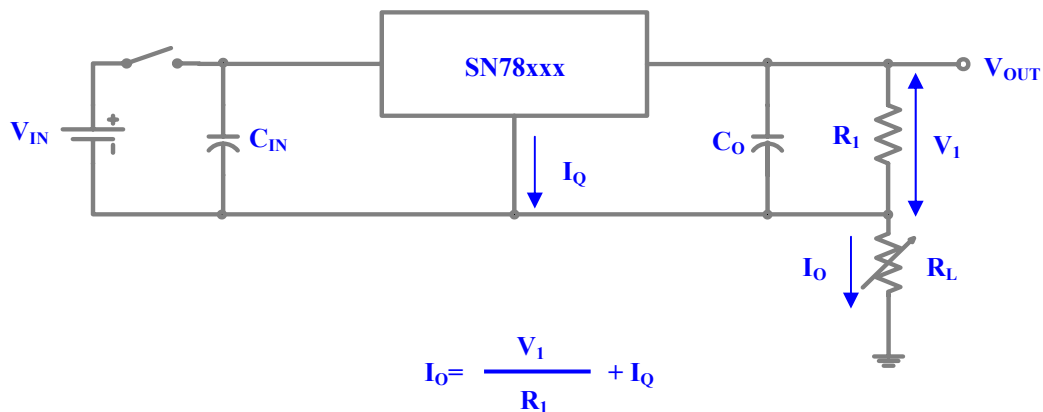

Adjustable Output Regulator

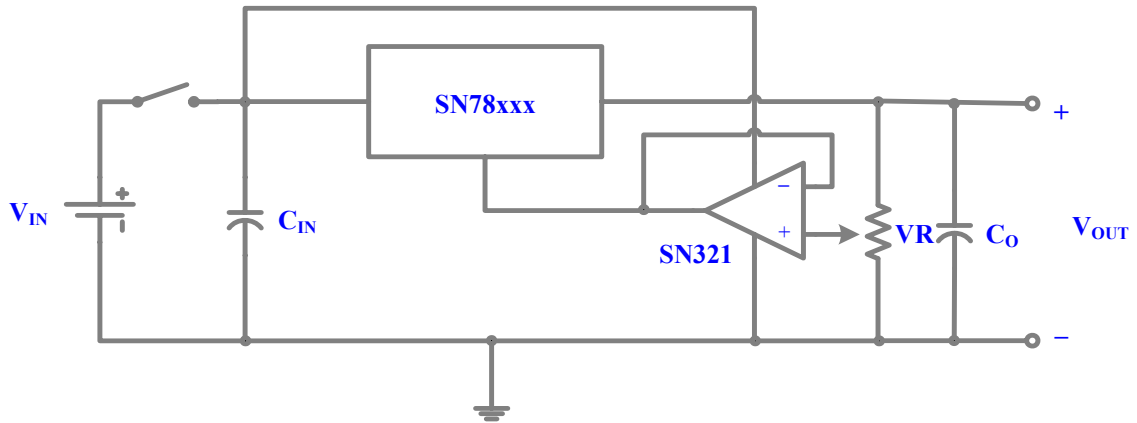

High Current Voltage Regulator

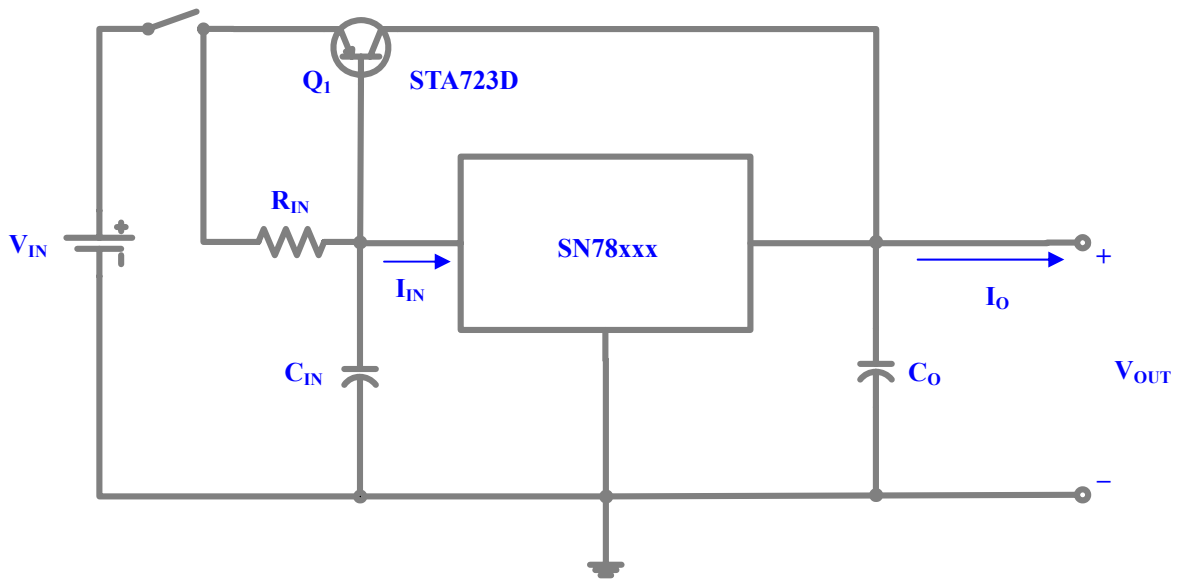

$$I_O = I_{IN} + \beta_{Q1}(I_{IN} - V_{BEQ1} / R_{IN})$$

Fig.1 Quiescent Current vs. Junction Temperature

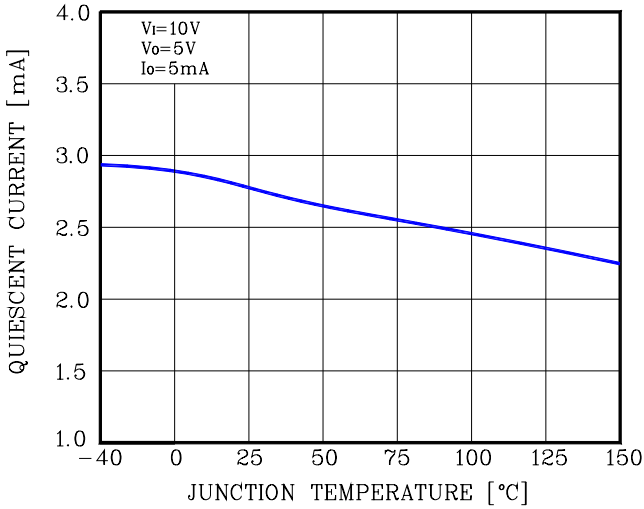

Fig.2 Output Peak Current vs. Input to Output Differential

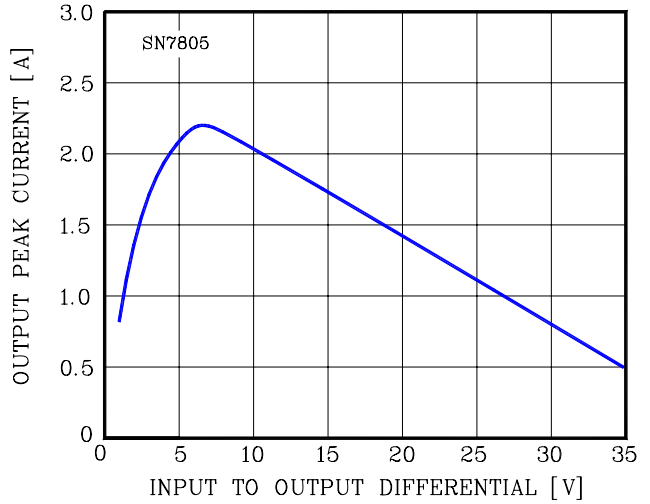

Fig.3 Output Voltage vs. Junction Temperature

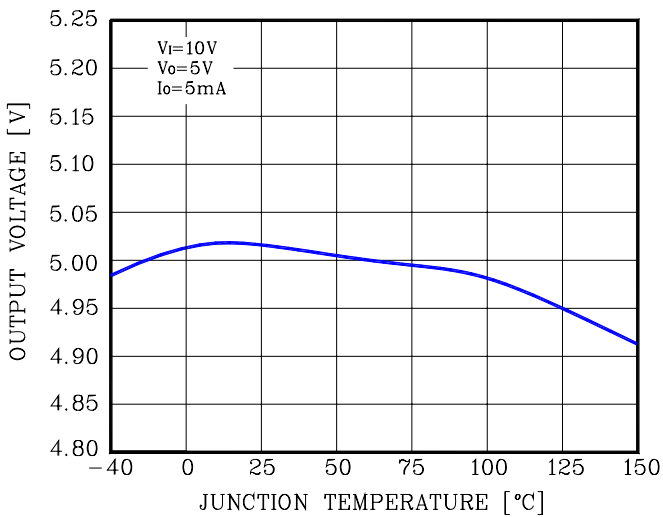

Fig.4 Dropout Voltage vs. Junction Temperature

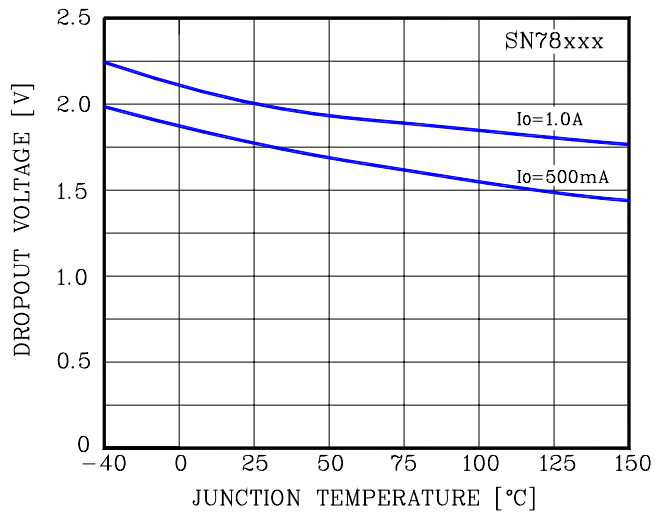

Fig.5 Line Transient Response

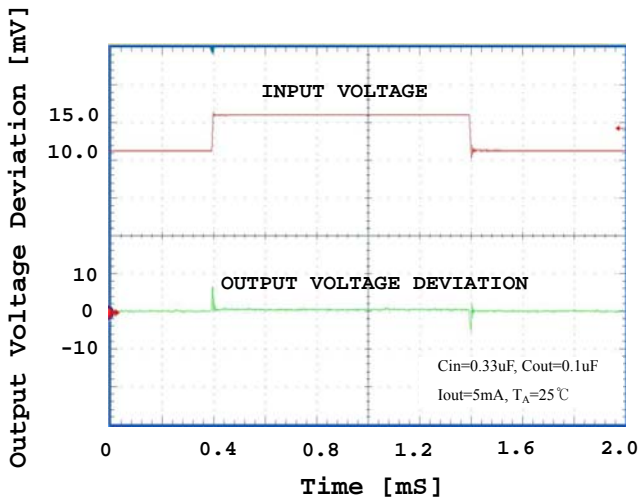
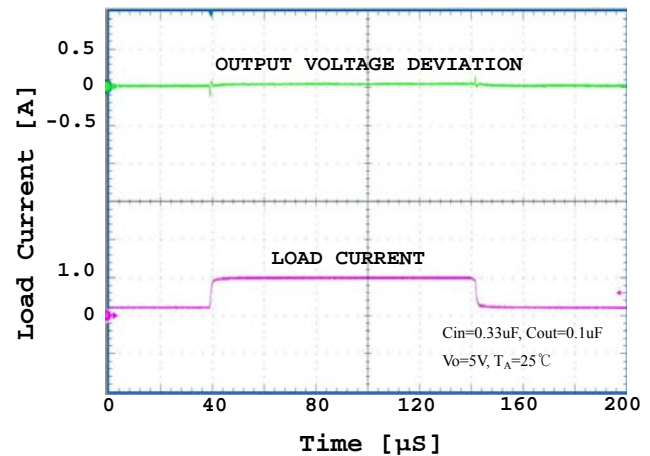
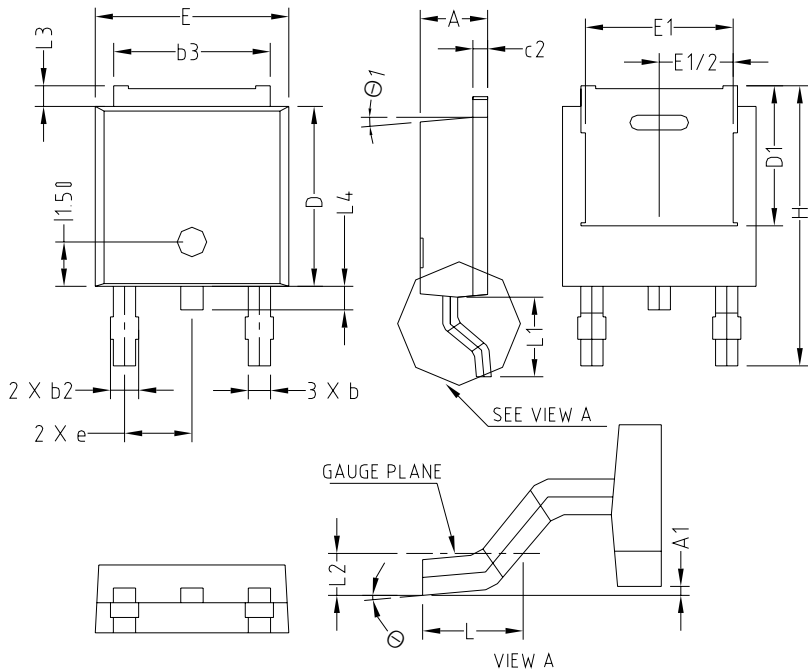

Fig.6 Load Transient Response



◆ TO-252-3L Outline Dimension (Unit : mm)



SYMBOL	MILLIMETERS			NOTE
	MINIMUM	NOMINAL	MAXIMUM	
A	2.20	2.30	2.40	
A1	0.00		0.127	
b	0.66	0.76	0.86	
b2	-	-	0.96	
b3	5.04	5.34	5.64	
c2	0.40	0.50	0.60	
D	5.90	6.10	6.30	
D1	4.75			
E	6.40	6.60	6.80	
E1	5.04			
e	2.30 BSC			
H	9.20	9.50	9.80	
L	1.27	1.47	1.67	
L1	2.50	2.70	2.90	
L2	0.508 BSC			
L3	0.50	0.70	0.90	
L4	0.60	0.80	1.00	
Θ	0°	-	10°	
Θ1	5°			

※ Recommend PCB solder land [Unit: mm]

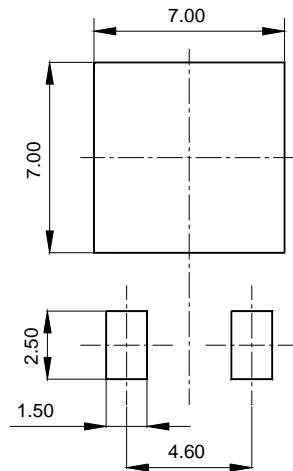

◆ TO-220F-3L Outline Dimension (Unit : mm)

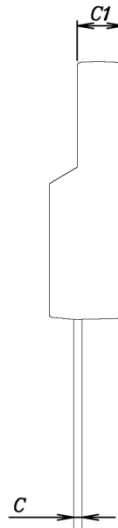
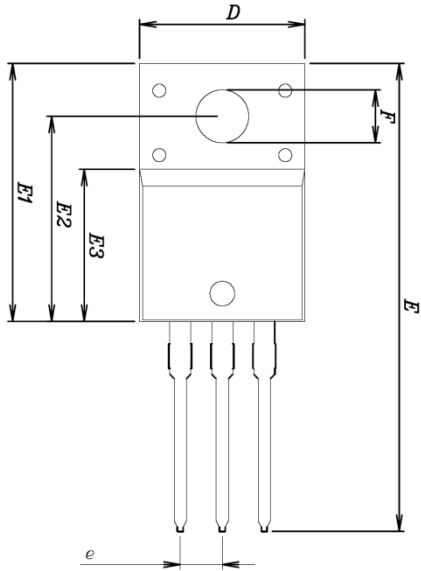

SYMBOL	MILLIMETERS			NOTE
	MINIMUM	NOMINAL	MAXIMUM	
A	-	-	4.60	
A1	2.45	2.50	2.55	
A2	1.95	2.00	2.05	
b	0.65	0.75	0.85	
b1	1.07	1.27	1.47	
C	0.40	0.50	0.60	
C1	2.70	2.80	2.90	
D	9.90	10.00	10.10	
E	28.00	-	28.60	
E1	15.50	15.60	15.70	
E2	12.30	12.40	12.50	
E3	9.15	9.20	9.25	
F	3.10	3.20	3.30	
G	3.30	3.40	3.50	
e	2.54 BSC			
L	12.40	-	13.00	
L1	3.46 BSC			

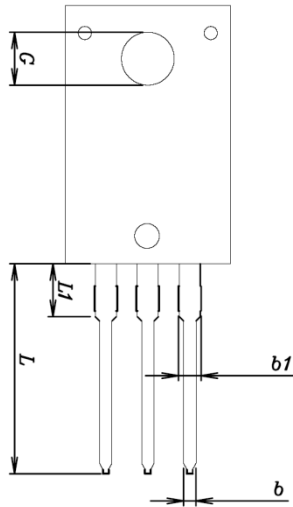
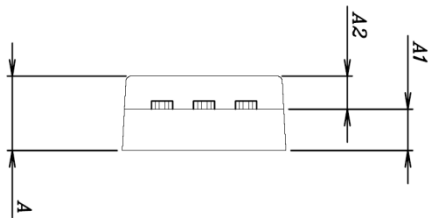

The AUK Corp. products are intended for the use as components in general electronic equipment (Office and communication equipment, measuring equipment, home appliance, etc.).

Please make sure that you consult with us before you use these AUK Corp. products in equipments which require high quality and / or reliability, and in equipments which could have major impact to the welfare of human life(atomic energy control, airplane, spaceship, transportation, combustion control, all types of safety device, etc.). AUK Corp. cannot accept liability to any damage which may occur in case these AUK Corp. products were used in the mentioned equipments without prior consultation with AUK Corp..

Specifications mentioned in this publication are subject to change without notice.