

## TRSL-9380FW-CXX0

### 3.3V / CWDM / 2.125 Gbps SFF LC 2X10 SINGLE-MODE TRANSCEIVER

#### FEATURES

- | 18-wavelength CWDM Transceivers
- | Duplex LC Single Mode Transceiver
- | Compliant with Fiber Channel 2X/1X SM-LC-L FC-PI
- | Compliant with IEEE 802.3z Gigabit Ethernet
- | Multi-sourced 2X10 SFF Package Style
- | CWDM DFB LD Transmitter
- | 23 dB Link Power Budget At Least
- | Analog Monitor Function
  - Transmitter Laser Bias Current
  - Transmitter Laser Optical Power Monitor
  - Receiver Photo Detector Current
- | AC/AC Coupled Signal Input / Output
- | LVPECL Signal Input / Output
- | LVTTTL Signal Detection Output
- | Single +3.3 V Power Supply
- | 0 to 70°C Operation
- | Wave Solderable and Aqueous Washable
- | Class 1 Laser International Safety Standard IEC-60825 Compliant

#### DESCRIPTION

The TRSL-9380FW-CXX0 series single mode transceivers is small form factor, low power, high performance module for bi-directional serial optical data communications such as IEEE 802.3z Gigabit Ethernet and 1X/2X Fiber channel. There are eighteen center wavelengths available from 1270 nm to 1610 nm, each step 20 nm. A guaranteed minimum optical link budget of 23 dB is offered. The transmitter section uses a multiple quantum well 1550 nm DFB laser and is a class 1 laser compliant according to International Safety Standard IEC-60825. The receiver section uses an integrated InGaAs detector preamplifier (IDP) mounted in an optical header and a limiting post-amplifier IC. A LVPECL logic interface simplifies interface to external circuitry.

#### LASER SAFETY

This single mode transceiver is a Class 1 laser product. It complies with IEC-60825 and FDA 21 CFR 1040.10 and 1040.11. The transceiver must be operated within the specified temperature and voltage limits. The optical ports of the module shall be terminated with an optical connector or with a dust plug.

#### APPLICATIONS

- | ATM Switches and Routers
- | SONET / SDH Switch Infrastructure
- | XDSL Applications

#### ORDER INFORMATION

P/No.	Bit Rate (Mb/s)	FC	Power Budget (dB)	Wavelength (nm)	Package	Temp. (°C)	TX Power (dBm)	RX Sens. (dBm)	Signal Detect Output
TRSL-9380FW-CXX0	2125/1063	200/100	> 23	CWDM*	2X10 LC	0 to 70	5 to 0	-23	LVTTTL

#### CWDM Wavelength (0 to 70°C)

Central Wavelength	Min. (nm)	Typ. (nm)	Max. (nm)	Central Wavelength	Min. (nm)	Typ. (nm)	Max. (nm)
-C270	1264.5	1270	1277.5	-C450	1444.5	1450	1457.5
-C290	1284.5	1290	1297.5	-C470	1464.5	1470	1477.5
-C310	1304.5	1310	1317.5	-C490	1484.5	1490	1497.5
-C330	1324.5	1330	1337.5	-C510	1504.5	1510	1517.5
-C350	1344.5	1350	1357.5	-C530	1524.5	1530	1537.5
-C370	1364.5	1370	1377.5	-C550	1544.5	1550	1557.5
-C390	1384.5	1390	1397.5	-C570	1564.5	1570	1577.5
-C410	1404.5	1410	1417.5	-C590	1584.5	1590	1597.5
-C430	1424.5	1430	1437.5	-C610	1604.5	1610	1617.5

CWDM\*: 18 Wavelengths from 1270 nm to 1610 nm, each step 20 nm.

Absolute Maximum Ratings						
Parameter	Symbol	Min	Max	Units	Notes	
Storage Temperature	Tstg	-40	85	°C		
Operating Temperature	Topr	0	70	°C	With air flow 1m/sec	
Soldering Temperature	---		260	°C	10 seconds on leads only	
Power Supply Voltage	Vcc	-0.5	3.6	V		
Input Voltage	---	-0.5	Vcc	V		
Output Current	Iout	0	50	mA		

Recommended Operating Conditions						
Parameter	Symbol	Min	Typ	Max	Units / Notes	
Power Supply Voltage	Vcc	3.135	3.3	3.465	V	
Operating Temperature	Topr	0		70	°C / air flow 1m/sec	
Data Rate		1000	2125		Mb/s	
Power Supply Current	Icc			280	mA	

Transmitter Specifications (0°C < Topr < 70°C, 3.135V < Vcc < 3.465V)						
Parameter	Symbol	Min	Typ	Max	Units	Notes
<b>Optical</b>						
Optical Transmit Power	Po	0	---	5	dBm	1
Output Center Wavelength	$\lambda$	$\lambda-5.5$	$\lambda$	$\lambda+7.5$	nm	2
Output Spectrum Width	$\Delta\lambda$	---		1	nm	-20 dB Width
Side Mode Suppression Ratio	SMSR	30			dB	
Extinction Ratio	ER		9	---	dB	
Optical Rise Time	t <sub>r</sub>			160	ps	20% to 80% Values
Optical Fall Time	t <sub>f</sub>			160	ps	20% to 80% Values
Relative Intensity Noise	RIN			-120	dB/Hz	
<b>Electrical</b>						
Data Input Current – Low	I <sub>IL</sub>	-350			μA	
Data Input Current – High	I <sub>IH</sub>			350	μA	
Differential Input Voltage	V <sub>IH</sub> - V <sub>IL</sub>	300		1600	mV	
Data Input Voltage – Low	V <sub>IL</sub> - V <sub>CC</sub>	-2.0		-1.58	V	3
Data Input Voltage -- High	V <sub>IH</sub> - V <sub>CC</sub>	-1.1		-0.74	V	3
TX Disable Input Voltage – Low	T <sub>DIS</sub>	0		0.5	V	
TX Disable Input Voltage – High	T <sub>DIS</sub>	2.0		Vcc	V	
TX Disable Assert Time	T <sub>ASSERT</sub>			10	μs	
TX Disable Deassert Time	T <sub>DEASSERT</sub>			50	μs	

- Notes: 1. Output power is power coupled into a 9/125 μm single mode fiber.  
 2. ITU-T G.694.2 CWDM wavelength from 1270 nm to 1610 nm, each step 20 nm.  
 3. These inputs are compatible with 10K, 10KH and 100K ECL and PECL inputs.

**Receiver Specifications (0°C < Topr < 70°C, 3.135V < Vcc < 3.465V)**

Parameter	Symbol	Min	Typ	Max	Units	Notes
<b>Optical</b>						
Sensitivity @ 2.125 Gbps	Sen1	---		-23	dBm	1
Sensitivity @ 1.25 Gbps	Sen2			-24	dBm	1
Maximum Input Power	Pin	-3		---	dBm	
Signal Detect -- Asserted	Pa	---	---	-23	dBm	Transition: low to high
Signal Detect -- Deasserted	Pd	-35	---	---	dBm	Transition: high to low
Signal detect -- Hysteresis		1.0	---	4.0	dB	
Wavelength of Operation		1100	---	1620	nm	
<b>Electrical</b>						
Data Output Voltage -- Low	V <sub>OL</sub> - V <sub>CC</sub>	-2.0		-1.58	V	2
Data Output Voltage -- High	V <sub>OH</sub> - V <sub>CC</sub>	-1.1		-0.74	V	2
Signal Detect Output Voltage -- Low	V <sub>SDL</sub>	0		0.8	V	
Signal Detect Output Voltage -- High	V <sub>SDH</sub>	2.0		V <sub>cc</sub> +0.3	V	

- Notes: 1. Minimum sensitivity and saturation levels at BER=1E-12 for a 2<sup>7</sup>-1 PRBS.  
 2. These outputs are compatible with 10K, 10KH and 100K ECL and PECL inputs.

**ANALOG DIAGNOSTICS FUNCTIONS**

Parameter	Symbol	Min	Typ	Max	Units	Notes
<b>Transmitter</b>						
Laser Bias Current Monitor	Bmon+, Bmon-	0		V <sub>cc</sub>	V	1
Monitor Photodiode Current Monitor	Pmon+, Pmon-	0		V <sub>cc</sub>	V	2
<b>Receiver</b>						
Received Photocurrent	Rpd	0		1	mA	3
Photodiode Responsivity	R	0.5	0.9	1.0	A/W	
Applied Voltage at VpdR pin	Vpd	2.4		V <sub>cc</sub>	V	3

- Notes: 1. PIN 17 and 18 provide an analog voltage output proportional to the laser bias current, based on the following formula:  $I_{bias} = V (Bmon+ - Bmon-) / 10 \Omega$ . See below the equivalent circuit.  
 2. PIN 19 and 20 provide an analog voltage output proportional to the monitor photodiode current, based on the following formula:  $I_{mon} = V (Pmon+ - Pmon-) / 200 \Omega$ . See below the equivalent circuit.  
 3. PIN 1 is used to monitor the received photocurrent. It must be connected to a positive voltage within the specified above. The received power is given by the photocurrent multiplied by the photodiode responsivity.

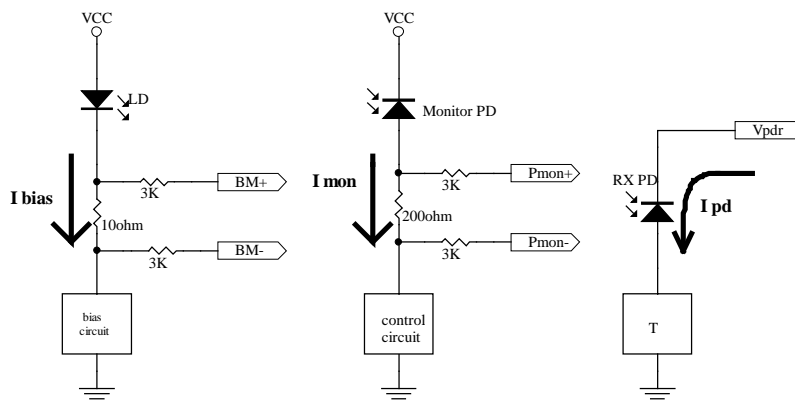

**Analog Monitoring Function Connections**

## CONNECTION DIAGRAM

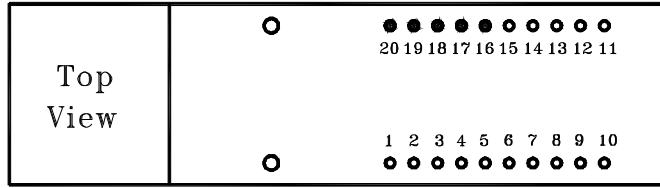

PIN	Symbol	Notes	PIN	Symbol	Notes
1	VpdR	Receiver power monitor. This pin must be connected to a positive power supply (Vcc), preferably via a small resistor. Supplier photocurrent and maybe used to monitor receiver power.	11	VccT	+3.3V dc transmitter power supply
2	VeeR	Receiver ground.	12	VeeT	Transmitter ground.
3	VeeR	Receiver ground.	13	T Dis	Transmitter Disable. Connect this pin to logic "1" to disable module. To enable module connect to logic low "0"
4	NC	No connected	14	TD +	Transmitter Data In
5	NC	No connected	15	TD -	Transmitter Data In Bar
6	VeeR	Receiver ground.	16	VeeT	Transmitter ground.
7	VccR	+3.3V dc receiver power supply	17	Bmon-	Laser Bias Monitoring - Negative End
8	SD	Signal detect. Logic 1 indicate a normal operation.	18	Bmon+	Laser Bias Monitoring - Positive End (Bmon+ - Bmon-) = 10 Ω X laser bias current
9	RD-	Receiver Dataout Bar	19	Pmon-	Laser Power Monitoring -- Negative end
10	RD+	Receiver Dataout	20	Pmon+	Laser Power Monitoring -- Positive end (Pmon+ - Pmon-) = 200 Ω X monitor photodiode current
MS	MS	Mounting Studs. Connect to Chassis Ground			

## RECOMMENDED CIRCUIT SCHEMATIC

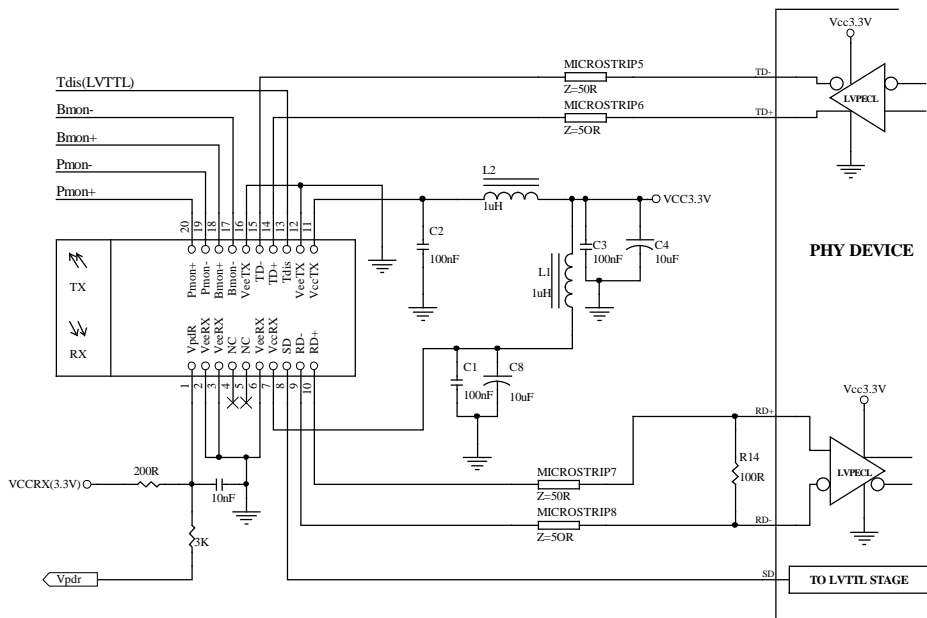

- Note: 1. TX input is terminated inside the module.  
 2. VeeR and VeeT are not internally connected to each other.  
 3. 50 Ω line pattern and component placements on TD+/TD- and RD+/RD- lines shall be symmetrical for better impedance matching.

\*\*\*\*\*  
**PACKAGE DIAGRAM**  
 \*\*\*\*\*

**Units in mm**

1) Standard Case

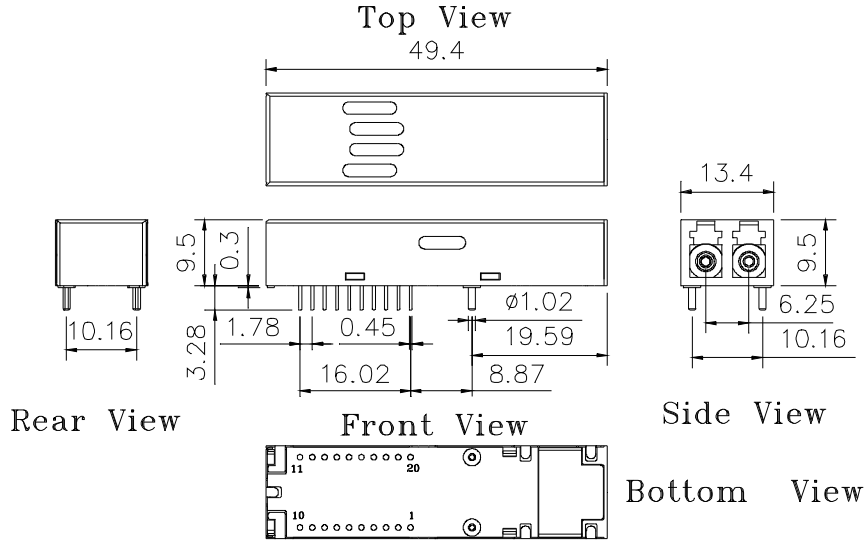

TRSL-9380FW-CXX0

2) Extended Case

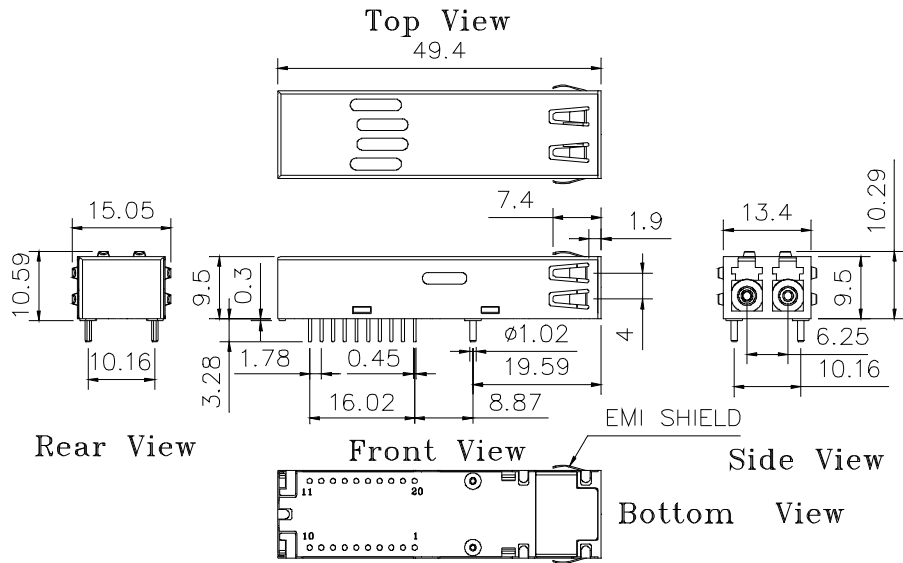

TRSL-9380FWE-CXX0

**Note:** Specifications subject to change without notice.