



LC87F5064A

8-Bit Single Chip Microcontroller with 64KB FEPRM and 2048 Byte RAM On Chip

Preliminary

Overview

The LC87F5064A microcontroller is 8-bit single chip microcontroller with the following on-chip functional blocks:

- CPU: Operable at a minimum bus cycle time of 100ns
- 64K bytes flash ROM (re-writeable on board)
- 2048 byte RAM
- two high performance 16 bit timer/counters (can be divided into 8 bit units)
- two 8 bit timers with prescalers
- timer for use as date/time clock
- one synchronous serial I/O ports (with automatic block transmit/receive function)
- one asynchronous/synchronous serial I/O port
- 12-bit PWM × 2
- 3-channel × 8-bit AD converter
- high speed 8-bit parallel interface
- 16-source 10-vectored interrupt system

All of the above functions are fabricated on a single chip.

Features

(1) Read Only Memory (Flash ROM)

- single 5V power supply, writeable on-board.
- block erase in 128 byte units
- 65536 × 8 bits (LC87F5064A)

(2) Bus Cycle Time

- 100ns (10MHz)

Note: The bus cycle time indicates ROM read time.

- Any and all SANYO products described or contained herein do not have specifications that can handle applications that require extremely high levels of reliability, such as life-support systems, aircraft's control systems, or other applications whose failure can be reasonably expected to result in serious physical and/or material damage. Consult with your SANYO representative nearest you before using any SANYO products described or contained herein in such applications.
- SANYO assumes no responsibility for equipment failures that result from using products at values that exceed, even momentarily, rated values (such as maximum ratings, operating condition ranges, or other parameters) listed in products specifications of any and all SANYO products described or contained herein.

(3) Minimum Instruction Cycle Time : 300ns (10MHz)

(4) Ports

- Input/output ports
 - Each bit data direction programmable 51 (P1n, P2n, P70 to P73, P80 to P82, PA2 to PA5, PBn, PCn)
 - Nibble data direction programmable 8 (P0n)
- Input ports 2 (XT1,XT2)
- PWM Output ports 2 (PWM0,PWM1)
- Oscillator pins 2 (CF1,CF2)
- Reset pin 1 (\overline{RES})
- Power supply 6 (VSS1 to 3,VDD1 to 3)

(5) Timers

- Timer0: 16 bit timer/counter with capture register
 - Mode 0: 2 channel 8 bit timer with programmable 8 bit prescaler and 8 bit capture register
 - Mode 1: 8 bit timer with 8 bit programmable prescaler and 8 bit capture register + 8 bit counter with 8 bit capture register
 - Mode 2: 16 bit timer with 8 bit programmable prescaler and 16 bit capture register
 - Mode 3: 16 bit counter with 16 bit capture register
- Timer1: PWM/16 bit timer/counter (with toggle output)
 - Mode 0: 8 bit timer (with toggle output) + 8 bit timer counter (with toggle output)
 - Mode 1: 2 channel 8 bit PWM
 - Mode 2: 16 bit timer/counter (with toggle output)
 - Mode 3: 16 bit timer (with toggle output) Lower order 8 bits can be used as PWM output.
- Base timer
 1. The clock signal can be selected from any of the following: sub-clock (32.768kHz crystal oscillator), system clock, and prescaler output for timer 0.
 2. Interrupts can be selected to occur at one of five different times.

(6) SIO

- SIO0: 8 bit synchronous serial interface
 1. LSB first/MSB first function available
 2. Internal 8-bit baud-rate generator (maximum transmit clock period $4/3 T_{CYC}$)
 3. Continuous automatic data communications (1 - 256 bits)
- SIO1: 8 bit asynchronous/synchronous serial interface
 - Mode 0: Synchronous 8 bit serial IO (2-wire or 3-wire, transmit clock 2 - 512 T_{CYC})
 - Mode 1: Asynchronous serial IO (half duplex, 8 data bits, 1 stop bit, baud rate 8 - 2048 T_{CYC})
 - Mode 2: Bus mode 1 (start bit, 8 data bits, transmit clock 2 - 512 T_{CYC})
 - Mode 3: Bus mode 2 (start detection, 8 data bits, stop detection)

(7) AD converter

- 8-bits \times 3-channels

(8) PWM

- 2 channel synchronous variable 12 bit PWM

(9) Parallel interface

- \overline{RS} , \overline{RD} , \overline{WR} , $\overline{CS0}$ - $\overline{CS2}$ Outputs (reversible polarity)
- read/write possible in 1 T_{CYC}

(10) Remote control receiver circuit (connected to P73/INT3/T0IN terminal)

- Noise rejection function (noise rejection filter time constant can selected from 1/32/128 T_{CYC})

(11) Watchdog timer

- The watchdog timer period set by external RC.
- Watchdog timer can be set to produce interrupt, system reset

(12) Interrupts

- 16-source, 10-vector interrupt:

1. Three level (low, high and highest) multiple interrupts are supported. During interrupt handling, an equal or lower level interrupt request is refused.
2. If interrupt requests to two or more vector addresses occur at once, the higher level interrupt takes precedence. In the case of equal priority levels, the vector with the lowest address takes precedence.

No.	Vector	Selectable Level	Interrupt signal
1	00003H	X or L	INT0
2	0000BH	X or L	INT1
3	00013H	H or L	INT2/T0L/INT4
4	0001BH	H or L	INT3/INT5/Base timer
5	00023H	H or L	TOH
6	0002BH	H or L	T1L/T1H
7	00033H	H or L	SIO0
8	0003BH	H or L	SIO1
9	00043H	H or L	ADC
10	0004BH	H or L	Port 0/PWM0, 1

- Priority Level: X>H>L
- For equal priority levels, vector with lowest address takes precedence.

(13) Subroutine stack levels

- 1024 levels max. Stack is located in RAM

(14) Multiplication and division

- 16 bit × 8 bit (executed in 5 cycles)
- 24 bit × 16 bit (12 cycles)
- 16 bit ÷ 8 bit (8 cycles)
- 24 bit ÷ 16 bit (12 cycles)

(15) Oscillation circuits

- On-chip RC oscillation circuit used for system clock
- On-chip CF oscillation circuit used for system clock
- On-chip Crystal oscillation circuit used for system clock and time-base clock

(16) Standby function

- HALT mode

HALT mode is used to reduce power consumption. Program execution is stopped. Peripheral circuits still operate.

1. Oscillation circuits are not stopped automatically
2. Release on system reset

- HOLD mode

HOLD mode is used to reduce the power dissipation. Both program execution and peripheral circuits are stopped.

1. CF, RC and crystal oscillation circuits stop automatically
2. Release occurs on any of the following conditions
 - input to the reset pin goes low
 - a specified level is input to at least one of INT0, INT1, INT2, INT4, INT5
 - an interrupt condition arises at port 0

- X'tal HOLD mode

X'tal HOLD mode is used to reduce power consumption. Program execution is stopped. All peripheral circuits except the base timer are stopped.

1. CF and RC oscillation circuits stop automatically
2. Crystal oscillator is maintained in its state at HOLD mode inception.
3. Release occurs on any of the following conditions
 - input to the reset pin goes low
 - a specified level is input to at least one of INT0, INT1, INT2, INT4, INT5
 - an interrupt condition arises at port 0
 - an interrupt condition arises at the base-timer

(17) Factory shipment

- delivery form QFP64E
- delivery form DIP64S

(18) Development Tools

- Evaluation chip : LC876098
- Emulator : EVA62S + ECB875000 (Evaluation chip board) + POD875000 (POD)

Pin Assignment

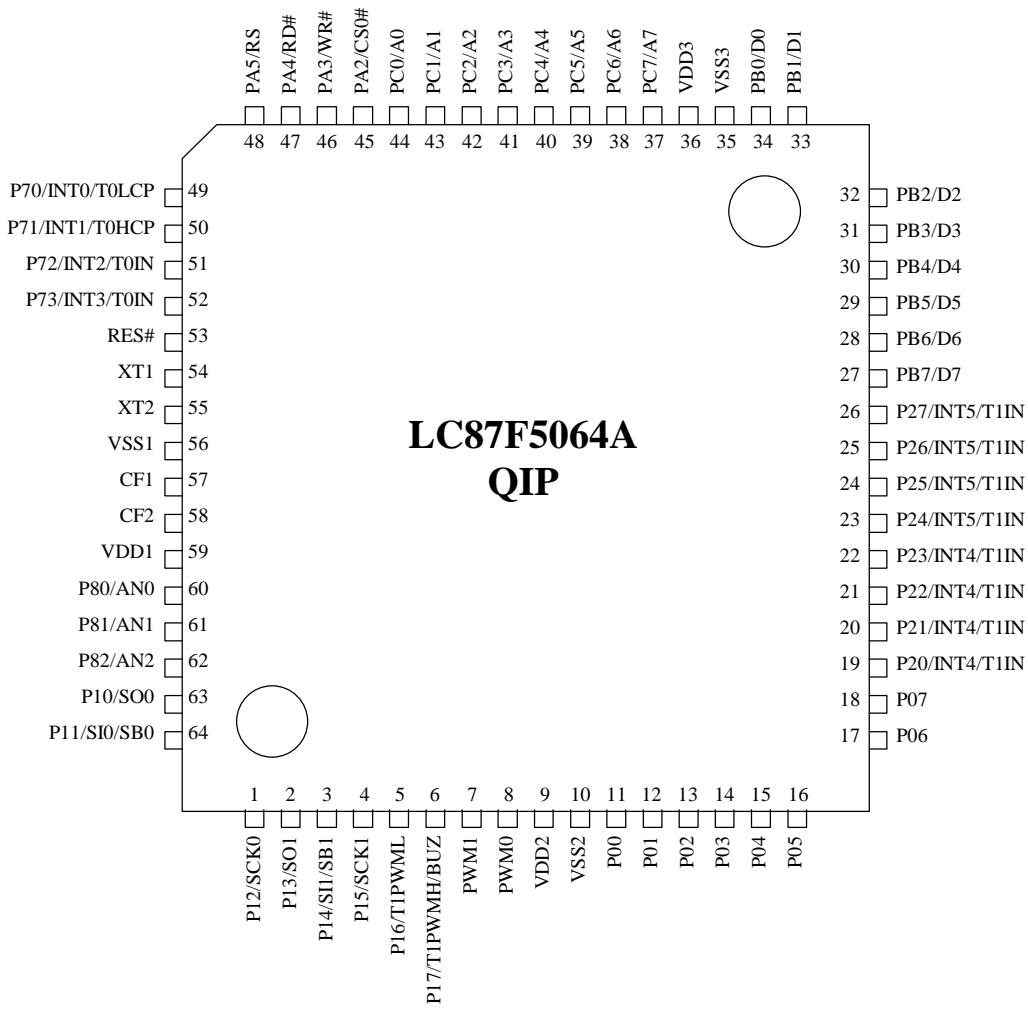

Package Dimension

(unit : mm)

3159

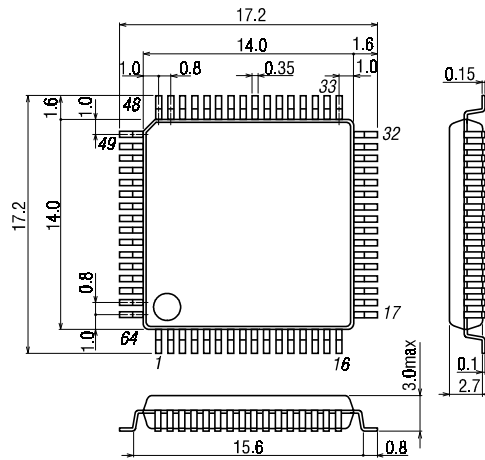

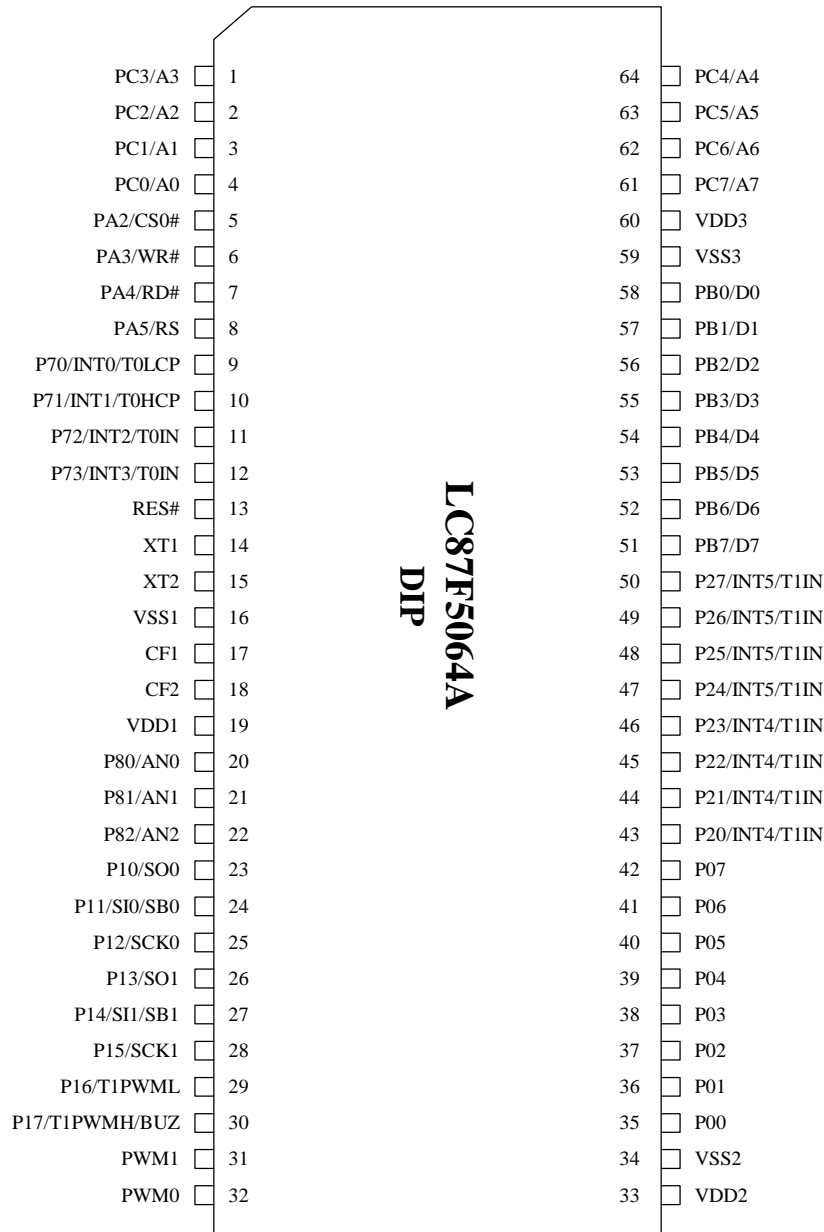

Package Dimension

(unit : mm)

3071

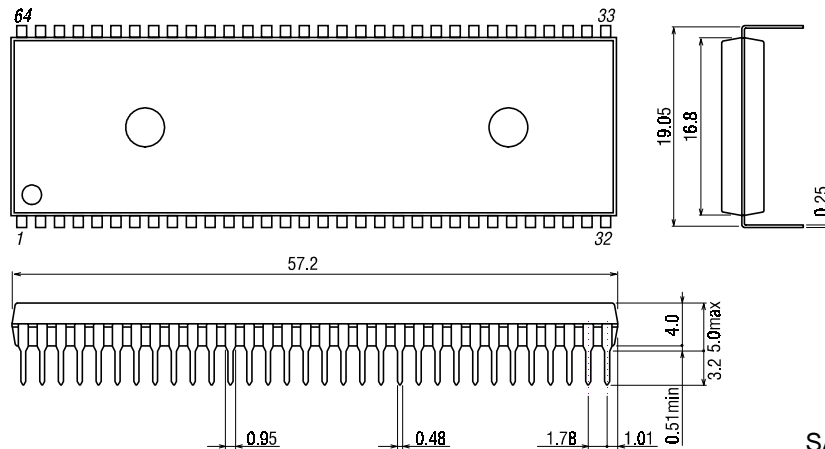

SANYO : DIP-64S

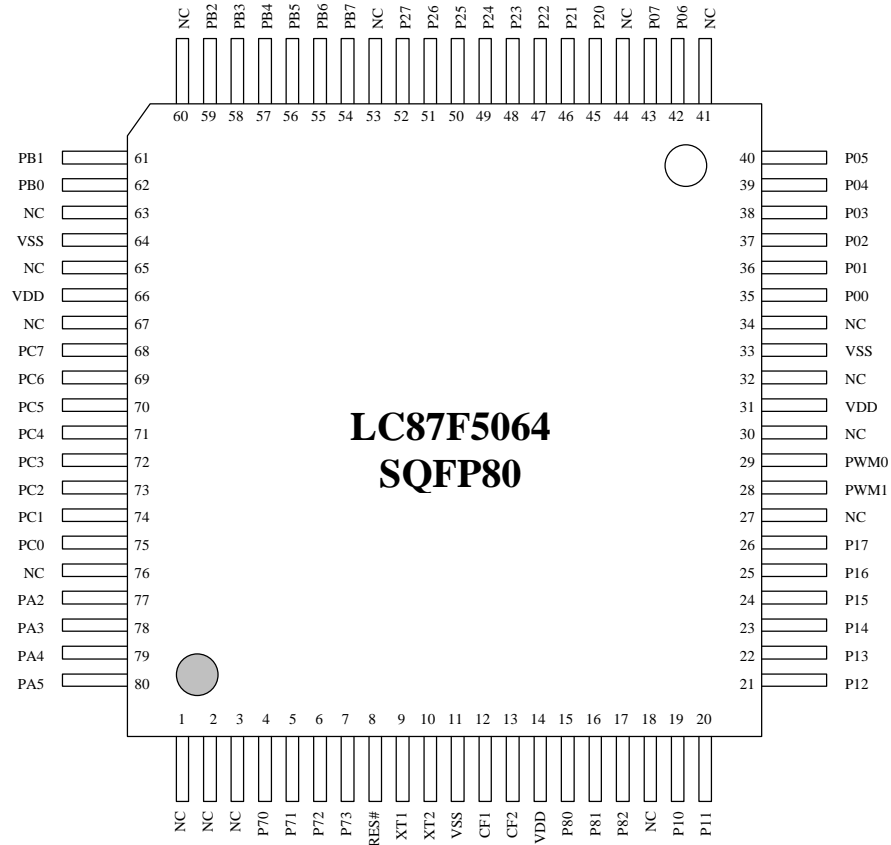

Package Dimension

(unit : mm)

3220

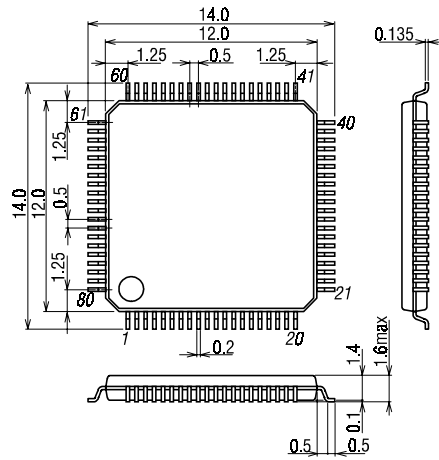

SANYO : SQFP-80

LC87F5064A

QIP64	NAME	DIP64	SQFP80
1	P12/SCK0	25	21
2	P13/SO1	26	22
3	P14/SI1/SB1	27	23
4	P15/SCK1	28	24
5	P16/T1PWML	29	25
6	P17/T1PWMH/BUZ	30	26
7	PWM1	31	28
8	PWM0	32	29
9	VDD2	33	31
10	VSS2	34	33
11	P00	35	35
12	P01	36	36
13	P02	37	37
14	P03	38	38
15	P04	39	39
16	P05	40	40
17	P06	41	42
18	P07	42	43
19	P20/INT4/T1IN	43	45
20	P21/INT4/T1IN	44	46
21	P22/INT4/T1IN	45	47
22	P23/INT4/T1IN	46	48
23	P24/INT5/T1IN	47	49
24	P25/INT5/T1IN	48	50
25	P26/INT5/T1IN	49	51
26	P27/INT5/T1IN	50	52
27	PB7/D7	51	54
28	PB6/D6	52	55
29	PB5/D5	53	56
30	PB4/D4	54	57
31	PB3/D3	55	58
32	PB2/D2	56	59

QIP64	NAME	DIP64	SQFP80
33	PB1/D1	57	61
34	PB0/D0	58	62
35	VSS3	59	64
36	VDD3	60	66
37	PC7/A7	61	68
38	PC6/A6	62	69
39	PC5/A5	63	70
40	PC4/A4	64	71
41	PC3/A3	1	72
42	PC2/A2	2	73
43	PC1/A1	3	74
44	PC0/A0	4	75
45	PA2/CS0#	5	77
46	PA3/WR#	6	78
47	PA4/RD#	7	79
48	PA5/RS	8	80
49	P70/INT0/T0LCP	9	4
50	P71/INT1/T0HCP	10	5
51	P72/INT2/T0IN	11	6
52	P73/INT3/T0IN	12	7
53	RES#	13	8
54	XT1	14	9
55	XT2	15	10
56	VSS1	16	11
57	CF1	17	12
58	CF2	18	13
59	VDD1	19	14
60	P80/AN0	20	15
61	P81/AN1	21	16
62	P82/AN2	22	17
63	P10/SO0	23	19
64	P11/SI0/SB0	24	20
-	NC	-	1
			2
			3
			18
			27
			30
			32
			34
			41
			44
			53
			60
			63
			65
			67
			76

System Block Diagram

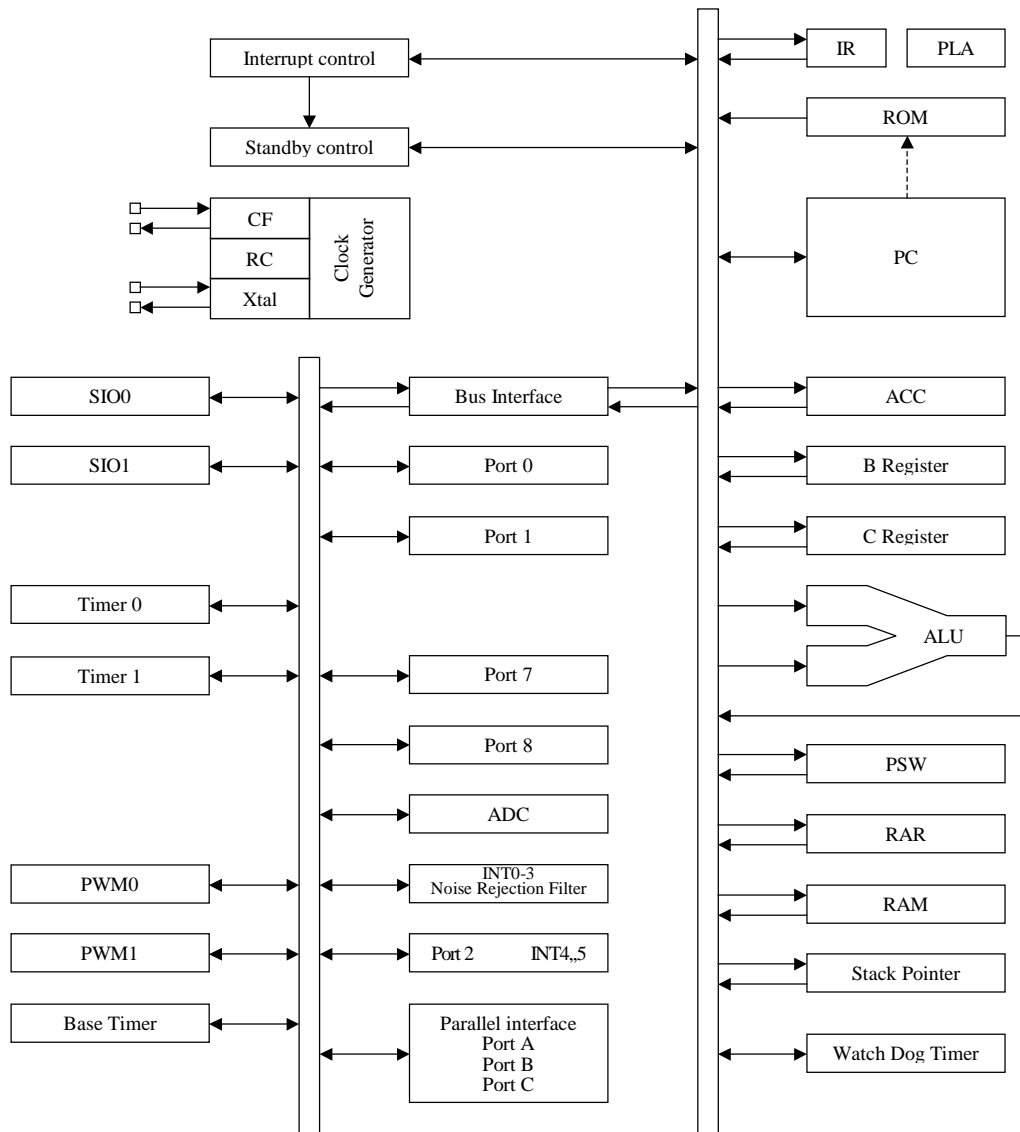

Pin Assignment

Pin Name	I/O	Pin Function	Option																		
VSS1 VSS2 VSS3	-	Negative power supply	No																		
VDD1 VDD2 VDD3	-	Positive power supply	No																		
Port 0 P00 - P07	I/O	<ul style="list-style-type: none"> •8-bit Input/output port •Data direction can be specified in nibble units •Use of pull-up resistor can be specified in nibble units •HOLD-release input •Input for port 0 interrupt 	Yes																		
Port 1 P10 - P17	I/O	<ul style="list-style-type: none"> •8-bit Input/output port •Data direction can be specified for each bit •Use of pull-up resistor can be specified for each bit •Other functions <ul style="list-style-type: none"> P10: SIO0 data output P11: SIO0 data input/bus input/output P12: SIO0 clock input/output P13: SIO1 data output P14: SIO1 data input/bus input/output P15: SIO1 clock input/output P16: Timer 1 PWML output P17: Timer 1 PWMH output/Buzzer output 	Yes																		
Port 2 P20 - P27	I/O	<ul style="list-style-type: none"> •8-bit Input/output port •Data direction can be specified for each bit •Use of pull-up resistor can be specified for each bit •Other functions <ul style="list-style-type: none"> P20-P23: INT4 input/HOLD release input/timer 1 event input /Timer 0L capture input/Timer 0H capture input P24-P27: INT5 input/HOLD release input/timer 1 event input /Timer 0L capture input /Timer 0H capture input <p>Interrupt receiver format</p> <table border="1" style="margin-left: 20px;"> <thead> <tr> <th></th> <th>Rising</th> <th>Falling</th> <th>Rising/ falling</th> <th>H level</th> <th>L level</th> </tr> </thead> <tbody> <tr> <td>INT4</td> <td>Yes</td> <td>Yes</td> <td>Yes</td> <td>No</td> <td>No</td> </tr> <tr> <td>INT5</td> <td>Yes</td> <td>Yes</td> <td>Yes</td> <td>No</td> <td>No</td> </tr> </tbody> </table>		Rising	Falling	Rising/ falling	H level	L level	INT4	Yes	Yes	Yes	No	No	INT5	Yes	Yes	Yes	No	No	Yes
	Rising	Falling	Rising/ falling	H level	L level																
INT4	Yes	Yes	Yes	No	No																
INT5	Yes	Yes	Yes	No	No																

(Continued)

Name	I/O	Function description	Option																														
Port 7 P70 - P73	I/O	<ul style="list-style-type: none"> •4-bit Input/output port •Data direction can be specified for each bit •Use of pull-up resistor can be specified for each bit •Other functions <ul style="list-style-type: none"> P70: INT0 input/HOLD release input/Timer0L capture input /Output for watchdog timer P71: INT1 input/HOLD release input/Timer0H capture input P72: INT2 input/HOLD release input/timer 0 event input /Timer0L capture input P73: INT3 input(noise rejection filter attached input) /timer 0 event input/Timer0H capture input <p>Interrupt receiver format</p> <table border="1"> <thead> <tr> <th></th> <th>Rising</th> <th>Falling</th> <th>Rising/ falling</th> <th>H level</th> <th>L level</th> </tr> </thead> <tbody> <tr> <td>INT0</td> <td>Yes</td> <td>Yes</td> <td>No</td> <td>Yes</td> <td>Yes</td> </tr> <tr> <td>INT1</td> <td>Yes</td> <td>Yes</td> <td>No</td> <td>Yes</td> <td>Yes</td> </tr> <tr> <td>INT2</td> <td>Yes</td> <td>Yes</td> <td>Yes</td> <td>No</td> <td>No</td> </tr> <tr> <td>INT3</td> <td>Yes</td> <td>Yes</td> <td>Yes</td> <td>No</td> <td>No</td> </tr> </tbody> </table>		Rising	Falling	Rising/ falling	H level	L level	INT0	Yes	Yes	No	Yes	Yes	INT1	Yes	Yes	No	Yes	Yes	INT2	Yes	Yes	Yes	No	No	INT3	Yes	Yes	Yes	No	No	No
	Rising	Falling	Rising/ falling	H level	L level																												
INT0	Yes	Yes	No	Yes	Yes																												
INT1	Yes	Yes	No	Yes	Yes																												
INT2	Yes	Yes	Yes	No	No																												
INT3	Yes	Yes	Yes	No	No																												
Port 8 P80 - P82	I/O	<ul style="list-style-type: none"> •3-bit Input/output port •Data direction can be specified for each bit •Other functions <ul style="list-style-type: none"> P80-P82: AD input port 	No																														
Port A PA2 - PA5	I/O	<ul style="list-style-type: none"> •4-bit Input/output port •Data direction can be specified for each bit •Use of pull-up resistor can be specified for each bit •Other functions <ul style="list-style-type: none"> PA2: Parallel interface output $\overline{CS0}$ PA3: Parallel interface output \overline{WR} PA4: Parallel interface output \overline{RD} PA5: Parallel interface output RS 	Yes																														
Port B PB0 - PB7	I/O	<ul style="list-style-type: none"> •8-bit Input/output port •Data direction can be specified for each bit •Use of pull-up resistor can be specified for each bit •Other functions <ul style="list-style-type: none"> PB0-PB7: Parallel interface data input/output; address output 	Yes																														
Port C PC0 - PC7	I/O	<ul style="list-style-type: none"> •8-bit Input/output port •Data direction can be specified for each bit •Use of pull-up resistor can be specified for each bit •Other functions <ul style="list-style-type: none"> PC0-PC7: Parallel interface address output 	Yes																														
PWM0	O	PWM0 output port	No																														
PWM1	O	PWM1 output port	No																														
\overline{RES}	I	Reset terminal	No																														
XT1	I	<ul style="list-style-type: none"> •Input for 32.768kHz crystal oscillation •Other function Input port When not in use, connect to VDD1.	No																														
XT2	I/O	<ul style="list-style-type: none"> •Output for 32.768kHz crystal oscillation •Other function General purpose input port When not in use, set to oscillation mode and leave open circuit	No																														
CF1	I	Input terminal for ceramic oscillator	No																														
CF2	O	Output terminal for ceramic oscillator	No																														

Port Output Configuration

Output configuration and pull-up resistor options are shown in the following table.
Input is possible even when port is set to output mode.

Terminal	Option applies to:	Option	Output Format	Pull-up resistor
P00-P07	1 bit units	1	CMOS	Programmable (Note 1)
		2	Nch-open drain	None
P10-P17 P20-P27	each bit	1	CMOS	Programmable
		2	Nch-open drain	Programmable
PA2-PA5 PB0-PB7(*) PC0-PC7	each bit	1	CMOS	Programmable
		2	Nch-open drain	Programmable
P70	-	None	Nch-open drain	Programmable
P71-P73	-	None	CMOS	Programmable
P80-P82	-	None	Nch-open drain	None
PWM0, PWM1	-	None	CMOS	None
XT1	-	None	Input only	None
XT2	-	None	Output for 32.768kHz crystal oscillation	None

Note 1 Programmable pull-up resistors of Port 0 can be attached in nibble units (P00-03, P04-07).

(*) When in parallel interface mode, PB0-PB7 output format is CMOS, regardless of any selected option.

Note: Connect as follows to reduce noise on VDD and increase the back-up time.
VSS1, VSS2 and VSS3 must be connected together and grounded.
The voltage of Port 7 should be fixed.

Example 1 : In hold mode, during backup, port output 'H' level is supplied from the back-up capacitor.

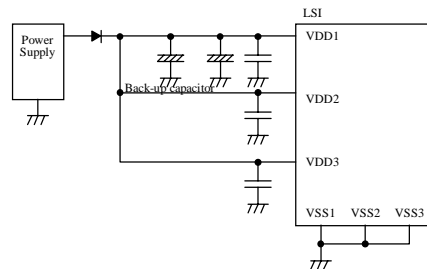

Example 2 : During backup in hold mode output is not held high and its value is unsettled.

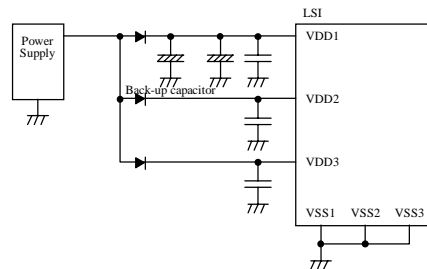

LC87F5064A

1. Absolute Maximum Ratings at Ta=25°C, VSS1=VSS2=VSS3=0V

Parameter	Symbol	Pins	Conditions	Ratings			unit		
				VDD[V]	min.	typ.		max.	
Supply voltage	VDDMAX	VDD1, VDD2, VDD3	VDD1=VDD2=VDD3		-0.3		+7.0	V	
Input voltage	VI(1)	XT1, XT2, CF1			-0.3		VDD+0.3		
Output voltage	VO(1)	PWM0, PWM1			-0.3		VDD+0.3		
Input/output voltage	VIO(1)	Ports 0, 1, 2 Ports 7, 8 Ports A, B, C PWM0, PWM1			-0.3		VDD+0.3		
High level output current	Peak output current	IOPH(1)	Ports 0, 1, 2 Ports A, B, C PWM0, PWM1	•CMOS output •For each pin.		-10		mA	
		IOPH(2)	Port 7	For each pin.		-3			
	Total output current	ΣIOAH(1)	Port 7	Total of all pins.		-5			
		ΣIOAH(2)	Port 8	Total of all pins.		-5			
		ΣIOAH(3)	Port 1 PWM0, PWM1	Total of all pins.		-20			
		ΣIOAH(4)	Port 0	Total of all pins.		-20			
		ΣIOAH(5)	Ports 2, B	Total of all pins.		-20			
ΣIOAH(6)	Ports A, C	Total of all pins.		-20					
Low level output current	Peak output current	IOPL(1)	P02-P07 Ports 1, 2 Ports A, B, C PWM0, PWM1	For each pin.			20		
		IOPL(2)	P00, P01	For each pin.			30		
		IOPL(3)	Ports 7, 8	For each pin.			5		
	Total output current	ΣIOAL(1)	Port 7	Total of all pins.				15	
		ΣIOAL(2)	Port 8	Total of all pins.				15	
		ΣIOAL(3)	Port 1 PWM0, PWM1	Total of all pins.				40	
		ΣIOAL(4)	Port 0	Total of all pins.				70	
ΣIOAL(5)	Ports 2, B	Total of all pins.				40			
ΣIOAL(6)	Ports A, C	Total of all pins.				40			
Maximum power dissipation	Pdmax	QFP64E	Ta=-30 to +70°C				430	mW	
Operating temperature range	Topg				-20		70	°C	
Storage temperature range	Tstg				-65		150		

LC87F5064A

2. Recommended Operating Range at Ta=-20°C to +70°C, VSS1=VSS2=VSS3=0V

Parameter	Symbol	Pins	Conditions	Ratings			unit	
				VDD[V]	min.	typ.		max.
Operating supply voltage range	VDD(1)	VDD1=VDD2=VDD3	$0.294\mu\text{s} \leq t_{\text{CYC}} \leq 200\mu\text{s}$		4.5		5.5	V
HOLD voltage	VHD	VDD1=VDD2=VDD3	RAM and the register data are kept in HOLD mode.		2.0		5.5	
Input high voltage	VIH(1)	•Ports 1, 2 •P71-P73 •P70 port input /interrupt		4.5 - 5.5	0.3VDD +0.7		VDD	
	VIH(2)	•Ports 0, 8 •Ports A, B, C		4.5 - 5.5	0.3VDD +0.7		VDD	
	VIH(3)	Port 70 Watchdog timer input		4.5 - 5.5	0.9VDD		VDD	
	VIH(4)	XT1, XT2, CF1, $\overline{\text{RES}}$		4.5 - 5.5	0.75VDD		VDD	
Input low voltage	VIL(1)	•Ports 1, 2 •P71-P73 •P70 port input /interrupt		4.5 - 5.5	VSS		0.1VDD +0.4	
	VIL(2)	•Ports 0, 8 •Ports A, B, C		4.5 - 5.5	VSS		0.15VDD +0.4	
	VIL(5)	Port 70 Watchdog timer input		4.5 - 5.5	VSS		0.8VDD -1.0	
	VIL(6)	XT1, XT2, CF1, $\overline{\text{RES}}$		4.5 - 5.5	VSS		0.25VDD	
Operation cycle time	tCYC			4.5 - 5.5	0.294		200	μs
External system clock frequency	FEXCF(1)	CF1	•CF2 open circuit •system clock divider set to 1/1 •external clock DUTY=50±5%	4.5 - 5.5	0.1		10	MHz
			•CF2 open circuit •system clock divider set to 1/2	4.5 - 5.5	0.2		20.4	

(Note 1) The oscillation constant is shown in Tables 1 and 2.

LC87F5064A

3. Electrical Characteristics at Ta=-20°C to +70°C, VSS1=VSS2=VSS3=0V

Parameter	Symbol	Pins	Conditions	Ratings			unit	
				VDD[V]	min.	typ.		max.
Input high current	IIH(1)	•Ports 0, 1, 2 •Ports 7, 8 •Ports A, B, C • $\overline{\text{RES}}$ •PWM0, PWM1	•Output disable •Pull-up resistor off •VIN=VDD (including off state leak current of output Tr.)	4.5 - 5.5			1	μA
	IIH(2)	XT1, XT2	When specified as an input port. VIN=VDD	4.5 - 5.5			1	
	IIH(3)	CF1	VIN=VDD	4.5 - 5.5			15	
Input low current	IIL(1)	•Ports 0, 1, 2 •Ports 7, 8 •Ports A, B, C • $\overline{\text{RES}}$ •PWM0, PWM1	•Output disable •Pull-up resistor off •VIN=VSS (including off state leak current of output Tr.)	4.5 - 5.5	-1			
	IIL(2)	XT1, XT2	When specified as an input port VIN=VSS	4.5 - 5.5	-1			
	IIL(3)	CF1	VIN=VSS	4.5 - 5.5	-15			
Output high current	VOH(1)	•Ports 0, 1, 2	IOH=-2.0mA	4.5 - 5.5	VDD-1			V
	VOH(2)	•Ports B, C •PWM0, PWM1	IOH=-0.1mA	4.5 - 5.5	VDD-0.5			
	VOH(3)	Port A	IOH=-5.0mA	4.5 - 5.5	VDD-1			
	VOH(4)		IOH=-1.0mA	4.5 - 5.5	VDD-0.5			
	VOH(5)	Port 7	IOH=-0.4mA	4.5 - 5.5	VDD-1			
Output low current	VOL(1)	•Ports 0, 1, 2 •Ports B, C	IOL=10mA	4.5 - 5.5			1.5	V
	VOL(2)	•PWM0, PWM1	IOL=1.6mA	4.5 - 5.5			0.4	
	VOL(3)							
	VOL(4)	P00, P01	IOL=30mA	4.5 - 5.5			1.5	
	VOL(5)	Ports 7, 8	IOL=1mA	4.5 - 5.5			0.4	
	VOL(6)							
	VOL(7)	Port A	IOL=15mA	4.5 - 5.5			1.5	
	VOL(8)		IOL=2mA	4.5 - 5.5			0.4	
Pull-up resistor	Rpu	•Ports 0, 1, 2 •Port 7 •Ports A, B, C	VOH=0.9VDD	4.5 - 5.5	15	40	70	k Ω
Hysteresis voltage	VHIS	• $\overline{\text{RES}}$		4.5 - 5.5		0.1VDD		V
Pin capacitance	CP	All pins	•Every other terminal connected to VSS. •f=1MHz •Ta=25°C	4.5 - 5.5		10		pF

4. Serial Input/Output Characteristics at Ta=-20°C to +70°C, VSS1=VSS2=VSS3=0V

Parameter	Symbol	Pins	Conditions	VDD[V]	Ratings			unit						
					min.	typ.	max.							
Serial clock	Input clock	Cycle	tSCK(1)	SCK0(P12)	Refer to figure 6	4.5 - 5.5	2		tCYC					
		Low level pulse width	tSCKL(1)				1							
			tSCKLA(1)				1							
		High level pulse width	tSCKH(1)				1							
			tSCKHA(1)				3(SIO0)							
		Output clock	Cycle	tSCK(2)			SCK1(P15)	Refer to figure 6		4.5 - 5.5	2		tCYC	
	Low level pulse width		tSCKL(2)		1									
			tSCKH(2)		1									
	High level pulse width		tSCK(3)	SCK0(P12)	<ul style="list-style-type: none"> •Use pull-up resistor (1kΩ) when output is open drain. •Refer to figure 6 	4.5 - 5.5	4/3				tSCK			
			Low level pulse width	tSCKL(3)								1/2		
				tSCKLA(2)			SCK0(P12) SIO0							3/4
		tSCKH(3)						1/2						
tSCKHA(2)	SCK0(P12) SIO0				2									
High level pulse width	Cycle	tSCK(4)	SCK1(P15)	<ul style="list-style-type: none"> •CMOS output option •Refer to figure 6 	4.5 - 5.5	2		tCYC						
	Low level pulse width	tSCKL(4)					1/2		tSCK					
		tSCKH(4)					1/2							
Serial input	Data set-up time	tsDI	SB0(P11), SB1(P14), SIO, SI1	<ul style="list-style-type: none"> •Data set-up to SIOCLK •Refer to figure 6 	4.5 - 5.5	0.03		μs						
	Data hold time	thDI					0.03							
Serial output	Output delay time	tdD0	SO0(P10), SO1(P13), SB0(O11), SB1(P14)	<ul style="list-style-type: none"> •Data set-up to SIOCLK •When port is open drain: Time delay from SIOCLK trailing edge to the SO data change. •Refer to figure 6 	4.5 - 5.5			1/3tCYC +0.05						

5. Parallel Input/Output Characteristics at Ta=-20°C to +70°C, VSS1=VSS2=VSS3=0V

Note: Port A terminals used as RS, \overline{WR} , \overline{RD} and \overline{CS} should be set to CMOS format.
Please refer to figures 8 and 9 for parallel output timing waveforms.

Parameter	Symbol	Pins	Conditions	Ratings			unit
				VDD[V]	min.	typ.	
Write cycle, Read cycle	tC(1)			4.5 - 5.5		1	tCYC
Address set-up time	tsA(1)	• \overline{WR} (PA3), PB0-PB7 • \overline{RD} (PA4), PC0-PC7	From address set-up until control signal changes	4.5 - 5.5	1/3tCYC -30ns		tCYC & ns
	tsA(2)	\overline{RD} (PA4), PC0-PC7		4.5 - 5.5	2/3tCYC -30ns		
Address hold time	thA(1)	\overline{RD} (PA4), PC0-PC7	From change of \overline{RD} until address change	4.5 - 5.5	1/6tCYC		ns
	thA(2)	\overline{WR} (PA3), PC0-PC7	From change of \overline{WR} until address change	4.5 - 5.5	5		
RS set-up tie	tsRS(1)	\overline{WR} (PA3), RS(PA5), \overline{CS} (PAX)	From change of RS, \overline{CS} until change in \overline{WR}	4.5 - 5.5	1/6tCYC -15ns		tCYC & ns
	tsRS(2)	\overline{RD} (PA4), RS(PA5)	from change of RS until change in \overline{RD}	4.5 - 5.5	1/6tCYC -15ns		
	tsRS(3)	\overline{RD} (PA4), RS(PA5)		4.5 - 5.5	1/3tCYC -15ns		
\overline{CS} set-up time	tsCS(1)	\overline{RD} (PA4), \overline{CS} (PAX)	From change in \overline{CS} until change in \overline{RD}	4.5 - 5.5	1/3tCYC -15ns		ns
	tsCS(2)	\overline{WR} (PA3), \overline{CS} (PAX)	From change in \overline{CS} until change in \overline{WR}	4.5 - 5.5	2/3tCYC -15ns		
RS hold time	thRS(1)	\overline{WR} (PA3), RS(PA5)	From change in \overline{WR} until change in RS	4.5 - 5.5	0		ns
	thRS(2)	\overline{RD} (PA4), RS(PA5), \overline{CS} (PAX)	From change in \overline{RD} until change in RS, CS	4.5 - 5.5	1/6tCYC		tCYC & ns
	thRS(3)	\overline{RD} (PA4), RS(PA5), \overline{CS} (PAX)		4.5 - 5.5	0		ns
\overline{CS} hold time	thCS(1)	\overline{RD} (PA4), RS(PA5)	From change in \overline{RD} until change in \overline{CS}	4.5 - 5.5	1/6tCYC		tCYC & ns
	thCS(2)	\overline{WR} (PA3), RS(PA5)	From change in \overline{WR} until change in \overline{CS}	4.5 - 5.5	0		ns
\overline{WR} 'H' pulse width	tWRH(1)	\overline{WR} (PA3)		4.5 - 5.5	1/6tCYC -5ns	1/6 tCYC	tCYC & ns
	tWRH(2)	\overline{WR} (PA3)		4.5 - 5.5	2/3tCYC -5ns	2/3 tCYC	
\overline{WR} 'L' pulse width	tWRL(1)	\overline{WR} (PA3)		4.5 - 5.5	1/6tCYC -5ns	1/6 tCYC	ns
	tWRL(2)	\overline{WR} (PA3)		4.5 - 5.5	1/3tCYC -5ns	1/3 tCYC	

(Continued)

Parameter	Symbol	Pins	Conditions	Ratings			unit
				VDD[V]	min.	typ.	
$\overline{\text{RD}}$ 'H' pulse width	tRDH(1)	$\overline{\text{RD}}$ (PA4)		4.5 - 5.5	1/6tCYC -5ns	1/6 tCYC	tCYC & ns
	tRDH(2)	$\overline{\text{RD}}$ (PA4)		4.5 - 5.5	1/3tCYC -5ns	1/3 tCYC	
$\overline{\text{RD}}$ 'L' pulse width	tRDL(1)	$\overline{\text{RD}}$ (PA4)		4.5 - 5.5	1/3tCYC -5ns	1/3 tCYC	
	tRDL(2)	$\overline{\text{RD}}$ (PA4)		4.5 - 5.5	1/2tCYC -5ns	1/2 tCYC	
Data write permission delay	tdDT(1)	$\overline{\text{RD}}$ (PA4), PB0-PB7	Time for permission, from $\overline{\text{RD}}$ leading edge until input data set-up (Note 1)	4.5 - 5.5			1/6tCYC -15ns
	tdDT(2)	$\overline{\text{RD}}$ (PA4), PB0-PB7		4.5 - 5.5			1/3tCYC -15ns
Input data set-up time	tsDTR(1)	$\overline{\text{RD}}$ (PA4), PB0-PB7	From input data set- up to $\overline{\text{RD}}$ leading edge. (Note 2)	4.5 - 5.5	40		ns
Input data hold time	thDTR(1)	$\overline{\text{RD}}$ (PA4), PB0-PB7	From $\overline{\text{RD}}$ leading edge until input data hold	4.5 - 5.5	0		ns
Output data set-up time	tsDTW(1)	$\overline{\text{RD}}$ (PA4), PB0-PB7	From output data set- up until $\overline{\text{WR}}$ leading edge	4.5 - 5.5	1/3tCYC -30ns		tCYC & ns
Output data set-up time	tsDTW(2)	$\overline{\text{RD}}$ (PA4), PB0-PB7		4.5 - 5.5	1/3tCYC -30ns		
Output data hold time	thDTW(1)	$\overline{\text{RD}}$ (PA4), PB0-PB7	From $\overline{\text{WR}}$ leading edge until output data hold	4.5 - 5.5	0		ns
	thDTW(2)			4.5 - 5.5	0		

Note 1 : Time until incorrect data of Low is disappeared.

Note 2 : Incorrect data of Low is not output in the period between tRDL(1) - tdDT(1).

6. Pulse input Conditions at Ta=-20°C to +70°C, VSS1=VSS2=VSS3=0V

Parameter	Symbol	Pins	Conditions	Ratings			unit
				VDD[V]	min.	typ.	
High/low level pulse width	tPIH(1) tPIL(1)	INT0(P70), INT1(P71), INT2(P72) INT4(P20-P23) INT5(P24-P27)	•Interrupt acceptable •Events to timer 0 and 1 can be input.	4.5 - 5.5	1		tCYC
	tPIH(2) tPIL(2)	INT3(P73) (The noise rejection clock select to 1/1.)	•Interrupt acceptable •Events to timer 0 can be input.	4.5 - 5.5	2		
	tPIH(3) tPIL(3)	INT3(P73) (The noise rejection clock select to 1/32.)	•Interrupt acceptable •Events to timer 0 can be input.	4.5 - 5.5	64		
	tPIH(4) tPIL(4)	INT3(P73) (The noise rejection clock select to 1/128.)	•Interrupt acceptable •Events to timer 0 can be input.	4.5 - 5.5	256		
	tPIL(5)	$\overline{\text{RES}}$	Reset acceptable	4.5 - 5.5	200		

7. AD Converter Characteristics at Ta=-20°C to +70°C, VSS1=VSS2=VSS3=0V

Parameter	Symbol	Pins	Conditions	Ratings			unit	
				VDD[V]	min.	typ.		max.
Resolution	N	AN0(P80) - AN2(P82)		4.5 - 5.5		8	bit	
Absolute precision	ET		(Note 2)	4.5 - 5.5			±1.5	LSB
Conversion time	TCAD		AD conversion time =32 × tCYC (ADCR2=0) (Note 3)	4.5 - 5.5	15.10 (tCYC= 0.588μs)		97.92 (tCYC= 3.06μs)	μs
			AD conversion time =64 × tCYC (ADCR2=1) (Note 3)	4.5 - 5.5	15.10 (tCYC= 0.294μs)		97.92 (tCYC= 1.53μs)	
Analog input voltage range	VAIN		4.5 - 5.5	VSS		VDD	V	
Analog port input current	IAINH		VAIN=VDD	4.5 - 5.5		1	μA	
	IAINL		VAIN=VSS	4.5 - 5.5	-1			

(Note 2) Absolute precision not including quantizing error (±1/2 LSB).

(Note 3) Conversion time means time from executing AD conversion instruction to loading complete digital value to register.

8. Current Dissipation Characteristics at Ta=-20°C to +70°C, VSS1=VSS2=VSS3=0V

Parameter	Symbol	Pins	Conditions	Ratings			unit	
				VDD[V]	min.	typ.		max.
Current flow during basic operation (Note 4)	IDDOP(1)	VDD	<ul style="list-style-type: none"> •FmCF=10MHz for Ceramic resonator oscillation •FmX'tal=32.768kHz for crystal oscillation •System clock: CF oscillation •Internal RC oscillation stopped. 	4.5 - 5.5		21	38	mA
	IDDOP(2)		<ul style="list-style-type: none"> •FmCF=5MHz for Ceramic resonator oscillation •FmX'tal=32.768kHz for crystal oscillation •System clock: CF oscillation •Internal RC oscillation stopped. 	3.0 - 5.5		7	15	
	IDDOP(3)		<ul style="list-style-type: none"> •FmCF=5MHz for Ceramic resonator oscillation •FmX'tal=32.768kHz for crystal oscillation •System clock: CF oscillation •Internal RC oscillation stopped. 	3.0 - 4.5		6	10	
	IDDOP(4)		<ul style="list-style-type: none"> •FmCF=0Hz (oscillation stops) •FmX'tal=32.768kHz for crystal oscillation •System clock: Internal RC oscillation 	4.5 - 5.5		6	9	
	IDDOP(5)		<ul style="list-style-type: none"> •FmCF=0Hz (oscillation stops) •FmX'tal=32.768kHz for crystal oscillation •System clock: Internal RC oscillation 	3.0 - 4.5		3	6	
	IDDOP(6)		<ul style="list-style-type: none"> •FmCF=0Hz (oscillation stops) •FmX'tal=32.768kHz for crystal oscillation •System clock: X'tal oscillation •Internal RC oscillation stopped. 	4.5 - 6.0		5	7	
	IDDOP(7)		<ul style="list-style-type: none"> •FmCF=0Hz (oscillation stops) •FmX'tal=32.768kHz for crystal oscillation •System clock: X'tal oscillation •Internal RC oscillation stopped. 	3.0 - 4.5		2	5	

(Continued)

Parameter	Symbol	Pins	Conditions	VDD[V]	Ratings			unit
					min.	typ.	max.	
Current flow: HALT mode (Note 4)	IDDHALT(1)	VDD	<ul style="list-style-type: none"> •HALT mode •FmCF=10MHz for Ceramic resonator oscillation •FmX'tal=32.768kHz for crystal oscillation •System clock: CF oscillation •Internal RC oscillation stopped. 	4.5 - 5.5		8	14	mA
	IDDHALT(2)		<ul style="list-style-type: none"> •HALT mode •FmCF=5MHz for Ceramic resonator oscillation •FmX'tal=32.768kHz for crystal oscillation •System clock: CF oscillation •Internal RC oscillation stopped. 	4.5 - 5.5		3.3	4	
	IDDHALT(3)		<ul style="list-style-type: none"> •HALT mode •FmCF=0Hz (oscillation stops) •FmX'tal=32.768kHz for crystal oscillation •System clock: Internal RC oscillation 	3.0 - 4.5		1.5	3	
	IDDHALT(4)		<ul style="list-style-type: none"> •HALT mode •FmCF=0Hz (oscillation stops) •FmX'tal=32.768kHz for crystal oscillation •System clock: X'tal oscillation •Internal RC oscillation stopped. 	4.5 - 5.5		1	1.5	
	IDDHALT(5)		<ul style="list-style-type: none"> •HALT mode •FmCF=0Hz (oscillation stops) •FmX'tal=32.768kHz for crystal oscillation •System clock: X'tal oscillation •Internal RC oscillation stopped. 	3.0 - 4.5		0.4	1	
	IDDHALT(6)		<ul style="list-style-type: none"> •HALT mode •FmCF=10MHz for Ceramic resonator oscillation •FmX'tal=32.768kHz for crystal oscillation •System clock: CF oscillation •Internal RC oscillation stopped. 	4.5 - 5.5		60	150	
	IDDHALT(7)		<ul style="list-style-type: none"> •HALT mode •FmCF=0Hz (oscillation stops) •FmX'tal=32.768kHz for crystal oscillation •System clock: X'tal oscillation •Internal RC oscillation stopped. 	3.0 - 4.5		15	70	

(Note 4) The currents of output transistors and pull-up MOS transistors are ignored.

9. F-ROM Write Characteristics at Ta=+10°C to +55°C, VSS1=VSS2=VSS3=0V

Parameter	Symbol	Pins	Conditions	Ratings			unit	
				VDD[V]	min.	typ.		max.
On-board write current	IDDFW(1)	VDD1	<ul style="list-style-type: none"> •128-byte write •including erase current 	4.5 - 5.5		30	65	mA
Write time	tFW(1)		<ul style="list-style-type: none"> •128-byte write •including data erase •Excluding time to fetch 28 byte data 	4.5 - 5.5		4.2	7.0	mS

Main system clock oscillation circuit characteristics

The characteristics in the table below is based on the following conditions:

1. Use the standard evaluation board SANYO has provided.
2. Use the peripheral parts with indicated value externally.
3. The peripheral parts value is a recommended value of oscillator manufacturer.

Table 1. Main system clock oscillation circuit characteristics using ceramic resonator

Frequency	Manufacturer	Oscillator	Circuit Parameters			Operating supply voltage range	Oscillation stabilizing time		Notes
			C1	C2	Rd1		typ	max	
10MHz	Murata	CSA10.0MTZ	33pF	33pF	0Ω	4.5 - 6.0V	0.05ms	0.50ms	
		CST10.0MTW	(30pF)	(30pF)	0Ω	4.5 - 6.0V	0.05ms	0.50ms	Built in C1,C2
	Kyocera	KBR-10.0M	33pF	33pF	0Ω	4.5 - 6.0V	0.05ms	0.50ms	
4MHz	Murata	CSA4.00MG	33pF	33pF	0Ω	4.5 - 6.0V	0.05ms	0.50ms	
		CST4.00MGW	(30pF)	(30pF)	0Ω	4.5 - 6.0V	0.05ms	0.50ms	Built in C1,C2
	Kyocera	KBR-4.0MSA	33pF	33pF	0Ω	4.5 - 6.0V	0.05ms	0.50ms	

*The oscillation stabilizing time is a period until the oscillation becomes stable after VDD becomes higher than minimum operating voltage. (Refer to Figure4)

Subsystem clock oscillation circuit characteristics

The characteristics in the table below is based on the following conditions:

1. Use the standard evaluation board SANYO has provided.
2. Use the peripheral parts with indicated value externally.
3. The peripheral parts value is a recommended value of oscillator manufacturer.

Table 2. Subsystem clock oscillation circuit characteristics using crystal oscillator

Frequency	Manufacturer	Oscillator	Circuit Parameters				Operating supply voltage range	Oscillation stabilizing time		Notes
			C3	C4	Rf	Rd2		typ	max	
32.768kHz	Seiko EPSON	C-002Rx	12pF	15pF	OPEN	300kΩ	4.5 - 6.0V	1.0s	3.0s	

*The oscillation stabilizing time is a period until the oscillation becomes stable after executing the instruction which starts the sub-clock oscillation or after releasing the HOLD mode. (Refer to Figure4)

(Notes) •Since the circuit pattern affects the oscillation frequency, place the oscillation-related parts as close to the oscillation pins as possible with the shortest possible pattern length.

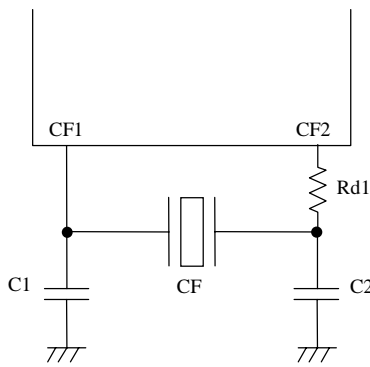

Figure 1 Ceramic oscillation circuit

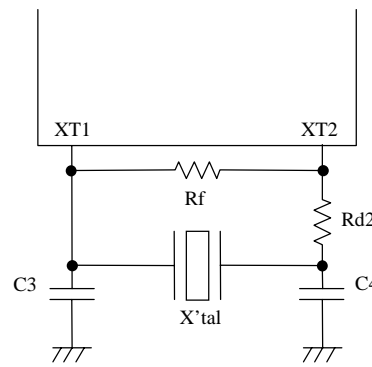

Figure 2 Crystal oscillation circuit

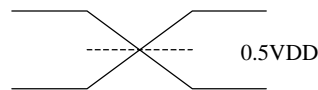

Figure 3 AC timing measurement point

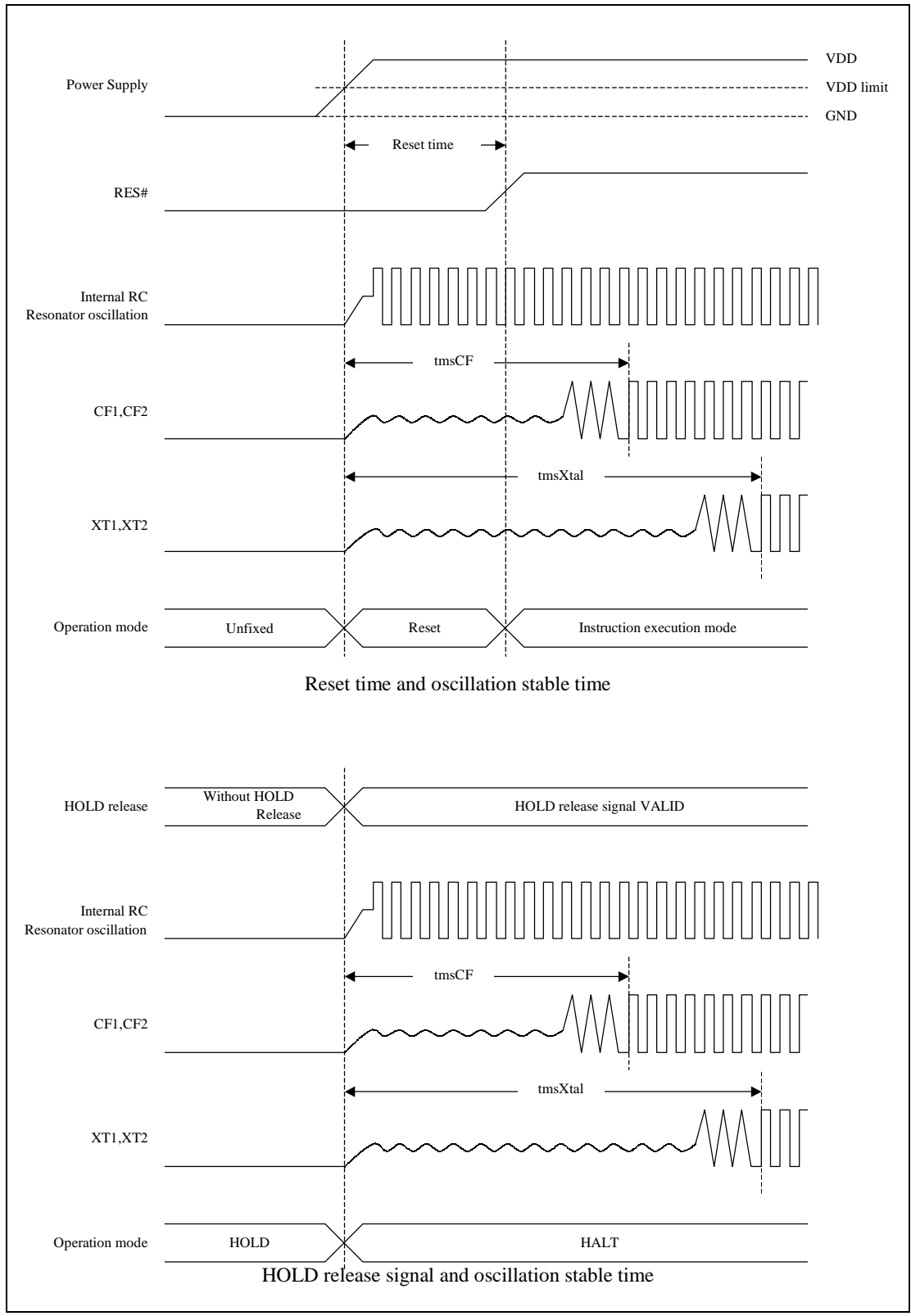

Figure 4 Oscillation stabilizing time

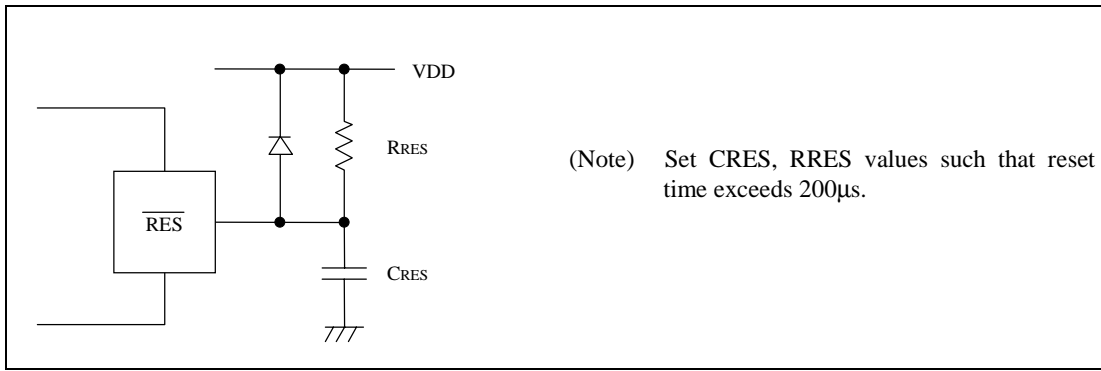

Figure 5 Reset circuit

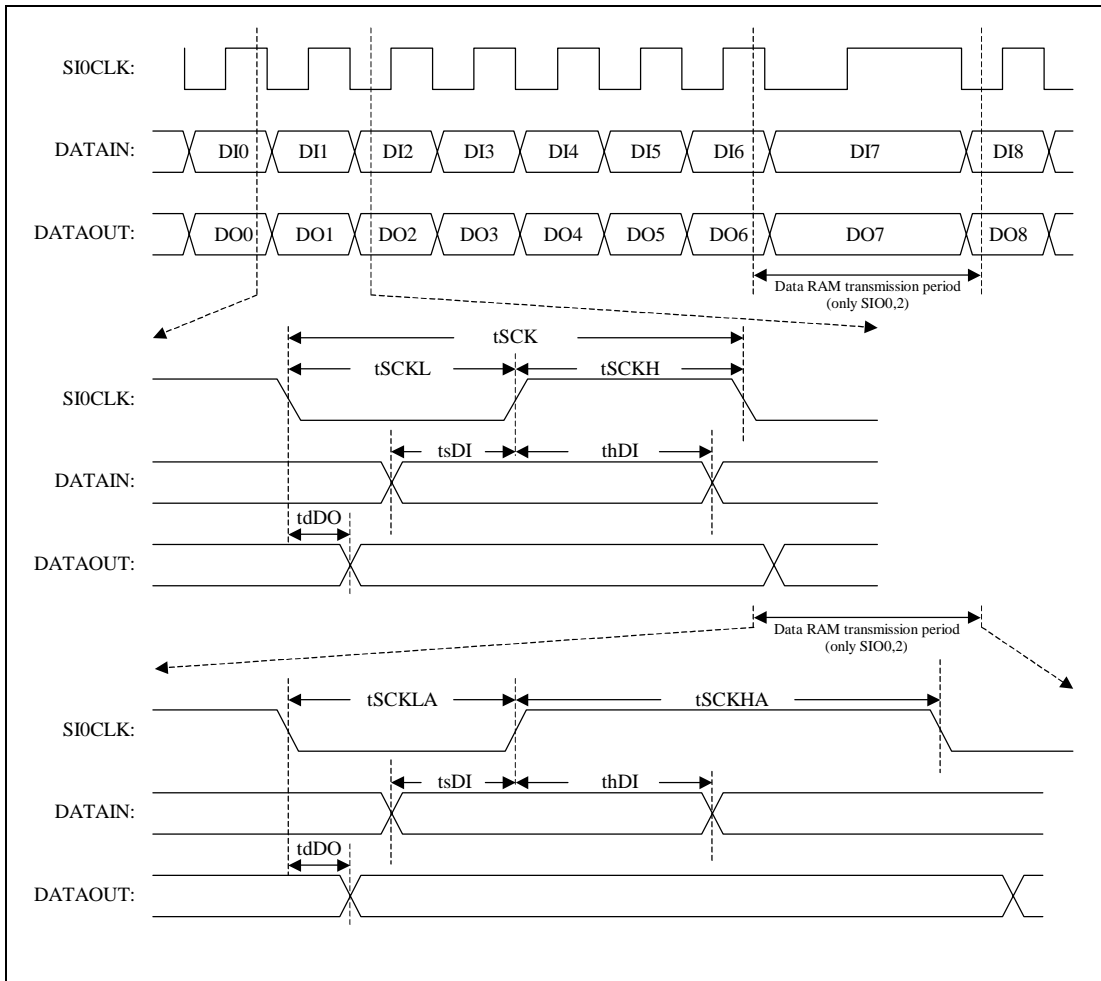

Figure 6 Serial input/output test condition

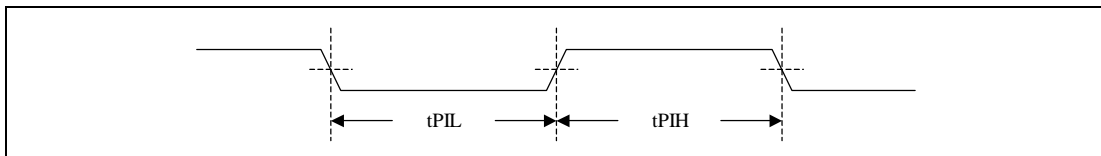
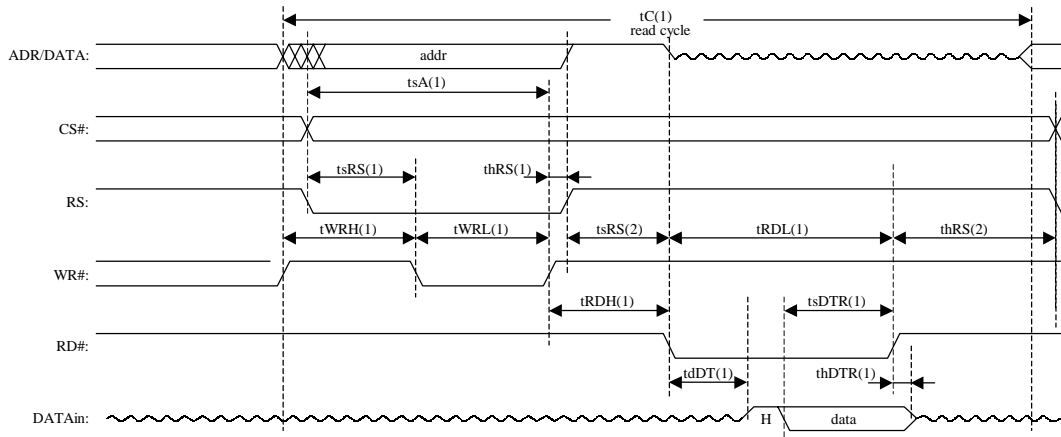

Figure 7 Pulse input timing condition

Parallel Input/Output timing waveform: Indirect Setting, Read Mode



Note: Port A terminals used as RS, \overline{WR} , \overline{RD} and \overline{CS} should be set to CMOS format.

Parallel Input/Output timing waveform: Indirect Setting, Write Mode

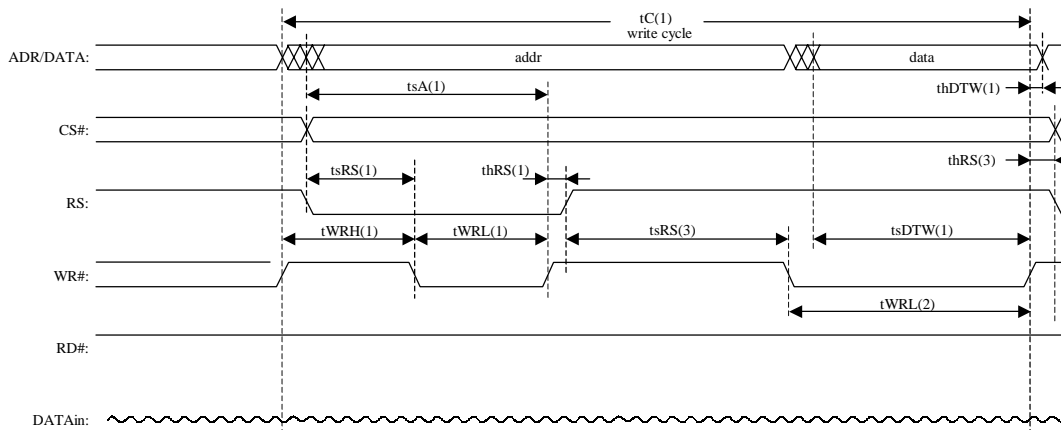

Note: Port A terminals used as RS, \overline{WR} , \overline{RD} and \overline{CS} should be set to CMOS format.

Figure 8 Indirect mode: Parallel Timing Waveforms

Parallel Input/Output timing waveform: Direct Setting, Read Mode

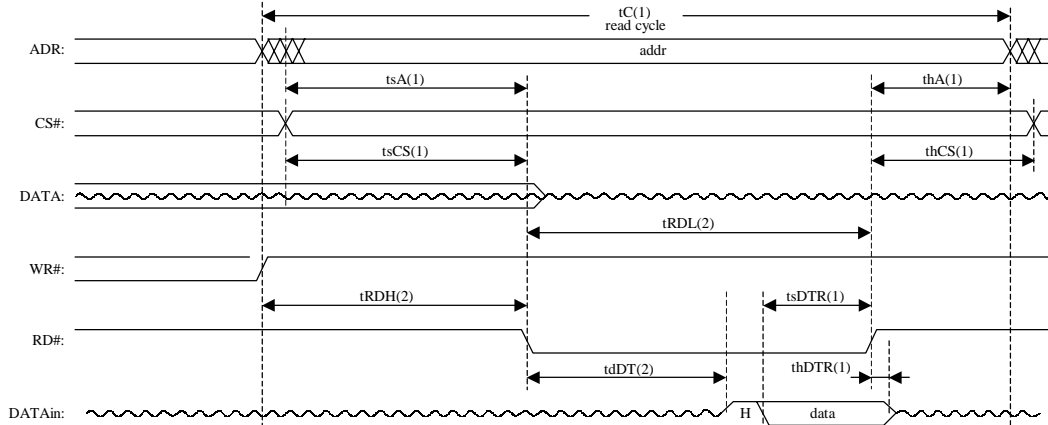

Note: Port A terminals used as RS, \overline{WR} , \overline{RD} and \overline{CS} should be set to CMOS format.

Parallel Input/Output timing waveform: Direct Setting, Write Mode

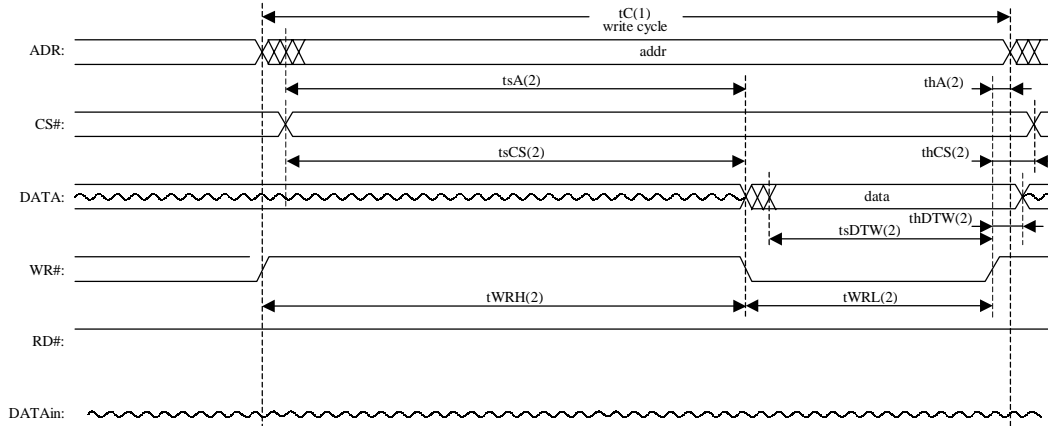

Note: Port A terminals used as RS, \overline{WR} , \overline{RD} and \overline{CS} should be set to CMOS format.

Figure 9 Direct Mode: Parallel Input/Output Timing Diagrams

memo:

- Specifications of any and all SANYO products described or contained herein stipulate the performance, characteristics, and functions of the described products in the independent state, and are not guarantees of the performance, characteristics, and functions of the described products as mounted in the customer's products or equipment. To verify symptoms and states that cannot be evaluated in an independent device, the customer should always evaluate and test devices mounted in the customer's products or equipment.
- SANYO Electric Co., Ltd. strives to supply high-quality high-reliability products. However, any and all semiconductor products fail with some probability. It is possible that these probabilistic failures could give rise to accidents or events that could endanger human lives, that could give rise to smoke or fire, or that could cause damage to other property. When designing equipment, adopt safety measures so that these kinds of accidents or events cannot occur. Such measures include but are not limited to protective circuits and error prevention circuits for safe design, redundant design, and structural design.
- In the event that any or all SANYO products (including technical data, services) described or contained herein are controlled under any of applicable local export control laws and regulations, such products must not be exported without obtaining the export license from the authorities concerned in accordance with the above law.
- No part of this publication may be reproduced or transmitted in any form or by any means, electronic or mechanical, including photocopying and recording, or any information storage or retrieval system, or otherwise, without the prior written permission of SANYO Electric Co., Ltd.
- Any and all information described or contained herein are subject to change without notice due to product/technology improvement, etc. When designing equipment, refer to the "Delivery Specification" for the SANYO product that you intend to use.
- Information (including circuit diagrams and circuit parameters) herein is for example only; it is not guaranteed for volume production. SANYO believes information herein is accurate and reliable, but no guarantees are made or implied regarding its use or any infringements of intellectual property rights or other rights of third parties.

This catalog provides information as of September, 2000. Specifications and information herein are subject to change without notice.