

Product Description

Sirenza Microdevices' SGB-6533 is a high performance SiGe HBT MMIC amplifier utilizing a Darlington configuration with an active bias network. The active bias network provides stable current over temperature and process Beta variations. Designed to run directly from a 5V supply the SGB-6533 does not require a drop resistor as compared to typical Darlington amplifiers. This robust amplifier features a Class 1C ESD rating, low thermal resistance, and unconditional stability. The SGB-6533 product is designed for high linearity 5V gain block applications that require small size and minimal external components. It is on chip matched to 50 ohm and an external bias inductor choke is required for the application band.

This product is available in a RoHS Compliant and Green package with matte tin finish, designated by the "Z" package suffix.

Functional Block Diagram

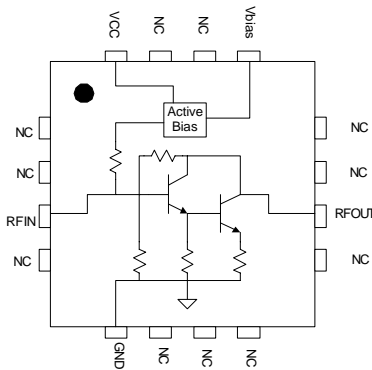

Key Specifications

| Symbol | Parameters: Test Conditions $Z_0 = 50\Omega$, $V_{CC} = 5.0V$, $I_c = 88mA$, $T = 30^\circ C$ | Unit | Min. | Typ. | Max. |
|--------------|---|--------------|------|------|------|
| f_O | Frequency of Operation | MHz | DC | | 3000 |
| S_{21} | Small Signal Gain – 850MHz | dB | | 25.0 | |
| | Small Signal Gain – 1950MHz | | 17.0 | 18.5 | 20.0 |
| | Small Signal Gain – 2400MHz | | | 17.0 | |
| P_{1dB} | Output Power at 1dB Compression – 850MHz | dBm | | 19.0 | |
| | Output Power at 1dB Compression – 1950MHz | | 17.0 | 18.5 | |
| | Output Power at 1dB Compression – 2400MHz | | | 18.0 | |
| OIP3 | Output IP3 – 850MHz | dB | | 32.0 | |
| | Output IP3 – 1950MHz | | 30.0 | 32.0 | |
| | Output IP3 – 2400MHz | | | 32.0 | |
| IRL | Input Return Loss @ 1950MHz | dB | 11.0 | 15.0 | |
| ORL | Output Return Loss @1950MHz | dB | 10.0 | 14.0 | |
| I_c | Current | mA | 76 | 88 | 98 |
| NF | Noise Figure @1950MHz | dB | | 3.7 | 4.7 |
| $R_{th,j-l}$ | Thermal Resistance (junction - lead) | $^\circ C/W$ | | 60 | |

SGB-6533

SGB-6533Z



DC – 3 GHz Active Bias Gain Block

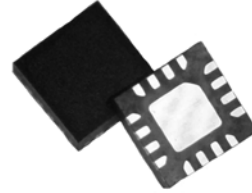

Product Features

- Available in Lead Free, RoHS compliant, & Green Packaging
- High reliability SiGe HBT Technology
- Robust Class 1C ESD
- Simple and small size
- $P_{1dB} = 18.5 \text{ dBm @ } 1950\text{MHz}$
- $IP3 = 32 \text{ dBm @ } 1950\text{MHz}$
- Low Thermal Resistance = 60 C/W

Applications

- 5V applications
- LO buffer amp
- RF pre-driver and RF receive path

Detailed Performance Table: Vcc=5V, Ic=88mA, T=25C, Z=50ohms

| Symbol | Parameter | Units | 100MHz | 500MHz | 850MHz | 1950MHz | 2400MHz | 3500MHz |
|--------|----------------------------------|-------|--------|--------|--------|---------|---------|---------|
| G | Small Signal Gain | dB | 28.4 | 26.9 | 25.0 | 18.5 | 17.0 | 13.1 |
| OIP3 | Output 3rd Order Intercept Point | dBm | | 32.0 | 32.0 | 32.0 | 32.0 | |
| P1dB | Output Power at 1dB Compression | dBm | | 19.1 | 19.0 | 18.5 | 18.0 | |
| IRL | Input Return Loss | dB | 15.1 | 19.1 | 26.4 | 15.0 | 13.5 | 8.7 |
| ORL | Output Return Loss | dB | 21.4 | 18.5 | 15.3 | 14.0 | 11.9 | 13.6 |
| S12 | Reverse Isolation | dB | 30.8 | 30.3 | 29.7 | 26.2 | 25.4 | 22.9 |
| NF | Noise Figure | dB | 4.6 | 3.1 | 3.1 | 3.7 | 4.2 | 4.9 |

Pin Out Description

| Pin # | Function | Description |
|----------------------|----------|---|
| 1,2,4,6,7,8,11,12,14 | NC | These are no connect pins. Leave them unconnected on the PC board. |
| 3 | RFIN | RF input pin. A DC voltage should not be connected externally to this pin |
| 5 | GND | An extra ground pin that is connected to the backside exposed paddle. Connection is optional. |
| 10 | RFOUT | RF Output pin. Bias is applied to the Darlington stage thru this pin. |
| 13 | VBIAS | This pin sources the current from the active bias circuit. Connect to pin 10 thru an inductor choke. |
| 16 | VCC | This is Vcc for the active bias circuit. |
| Back-side | GND | The backside exposed paddle is the main electrical GND and requires multiple vias in the PC board to GND. It is also the main thermal path. |

Simplified Device Schematic

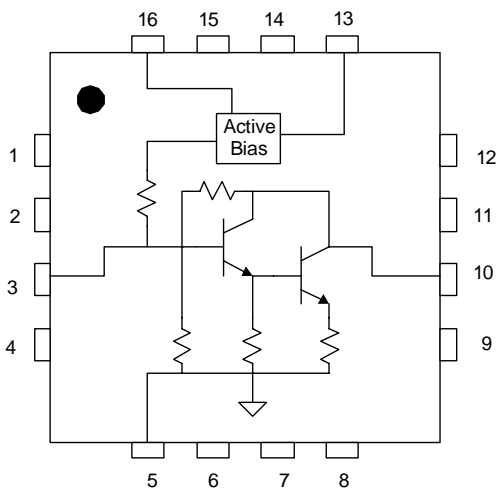

Caution: ESD Sensitive

Appropriate precaution in handling, packaging and testing devices must be observed.

Absolute Maximum Ratings

| Parameters | Value | Unit |
|--|-------------|------|
| Current (Ic total) | 150 | mA |
| Device Voltage (V _D) | 6.5 | V |
| Power Dissipation | 0.75 | W |
| Operating Lead Temperature (T _L) | -40 to +85 | °C |
| RF Input Power, Zload = 50 ohm | 15 | dBm |
| RF Input Power, Zload > 10:1 VSWR | 7 | dBm |
| Storage Temperature Range | -40 to +150 | °C |
| Operating Junction Temperature (T _J) | +150 | °C |

Operation of this device beyond any one of these limits may cause permanent damage. For reliable continuous operation the device voltage and current must not exceed the maximum operating values specified in the table on page one.

Bias conditions should also satisfy the following expression:
 $I_D V_D < (T_J - T_L) / R_{TH} \text{ } ^\circ\text{C/W}$

Evaluation Board Data ($V_{CC}=V_{BIAS} = 5.0V$, $I_C = 88mA$) Bias Tee is substituted for DC feed inductor (L1)

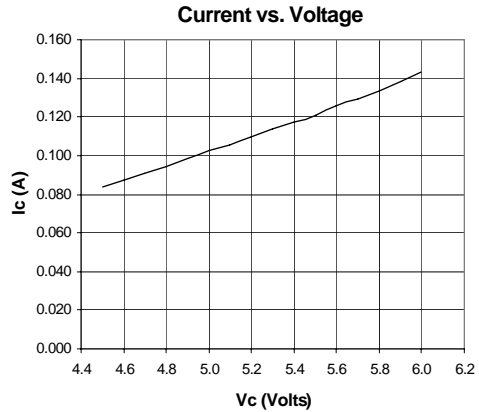
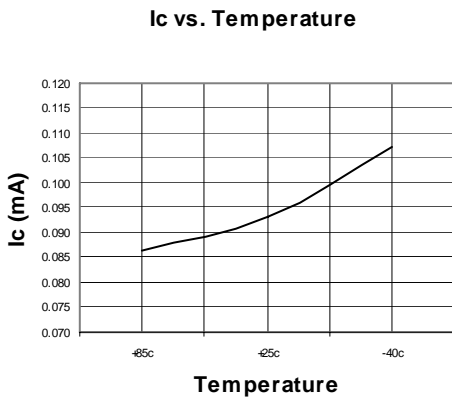
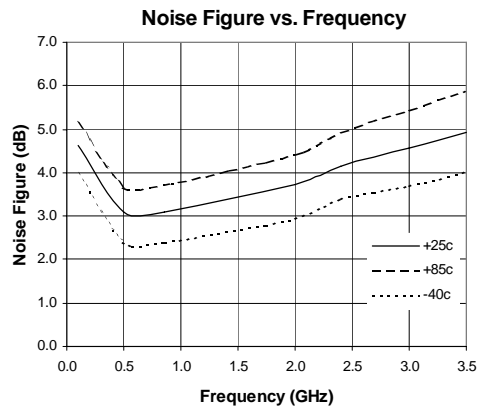
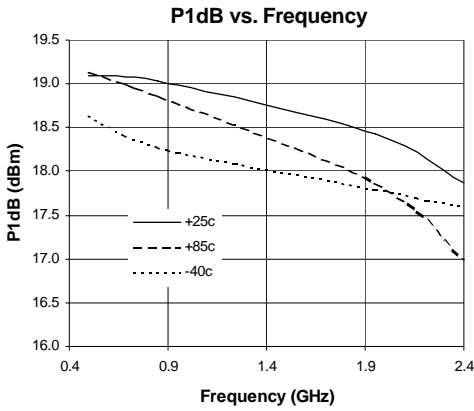
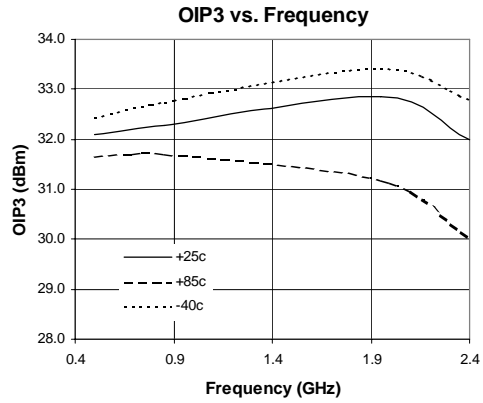
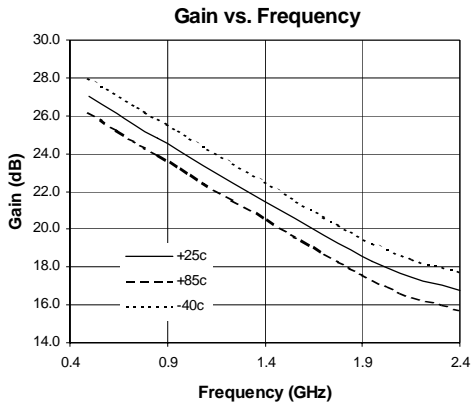

Evaluation Board Data ($V_{CC}=V_{BIAS} = 5.0V$, $I_C = 88mA$) Bias Tee is substituted for DC feed inductor (L1)

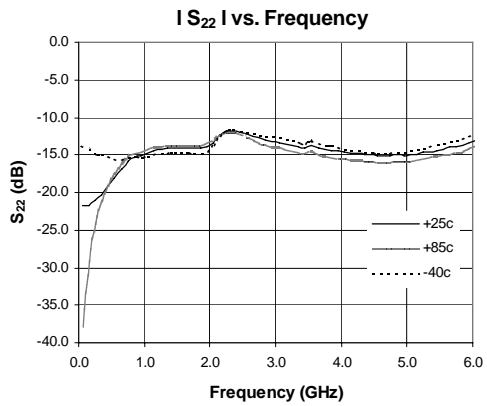
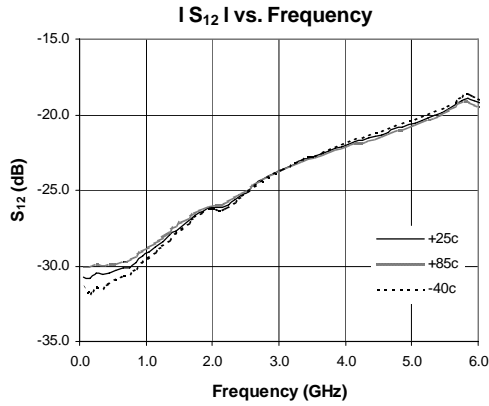
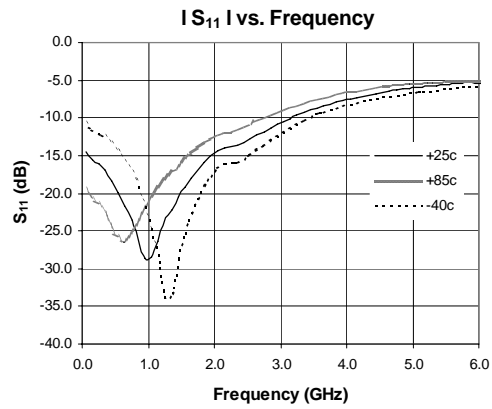
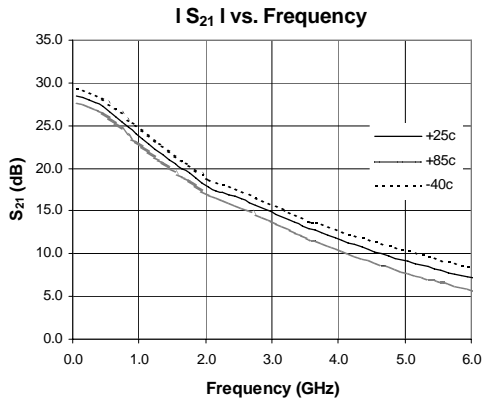

Typical Evaluation Board Schematic for 5.0V

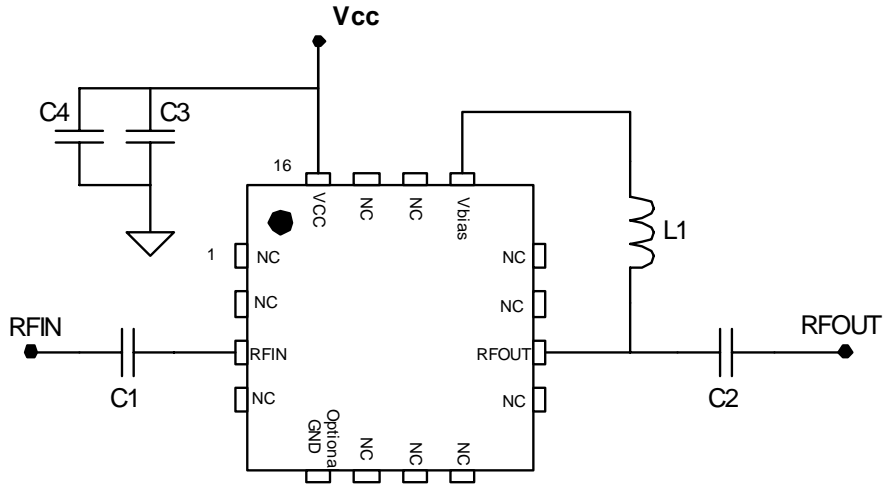

Evaluation Board - Board material GETEK, 31mil thick, Dk=4.2, 1 oz. copper

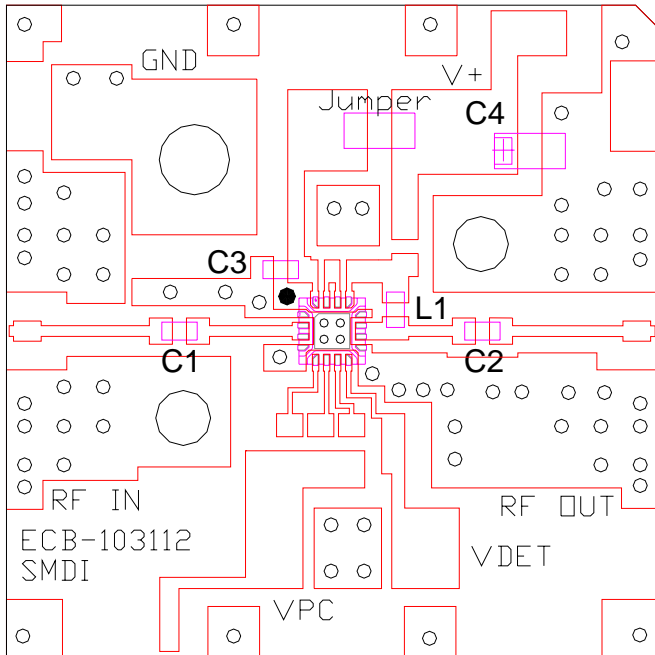

Component Values By Band

| Designator | 500MHz | 850MHz | 1950MHz | 2400MHz |
|------------|--------|--------|---------|---------|
| C3 | 1000pF | 1000pF | 1000pF | 1000pF |
| C4* | 1uF | 1uF | 1uF | 1uF |
| C1, C2 | 220pF | 68pF | 43pF | 22pF |
| L1 | 68 nH | 33nH | 22nH | 18nH |

* C4 is optional depending on application and filtering. Not required for SGB device operation.

Note: The amplifier can be run from a 8V supply by simply inserting a 33 ohm resistor in series with Vcc.

Part Marking

The part will be symbolized with an "SGB-6533" for Sn/Pb plating or "SGB-65Z" for RoHS green compliant product. Marking designator will be on the top surface of the package.

Part Number Ordering Information

| Part Number | Reel Size | Devices/Reel |
|-------------|-----------|--------------|
| SGB-6533 | 13" | 3000 |
| SGB-6533Z | 13" | 3000 |

Package Outline Drawing (Dimensions in mm)

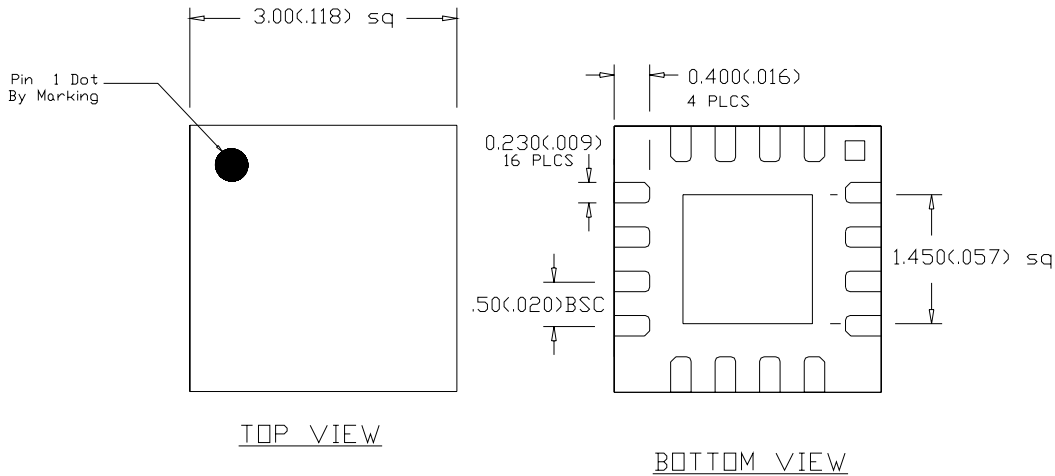

Recommended Land Pattern (dimensions in mm[in].):

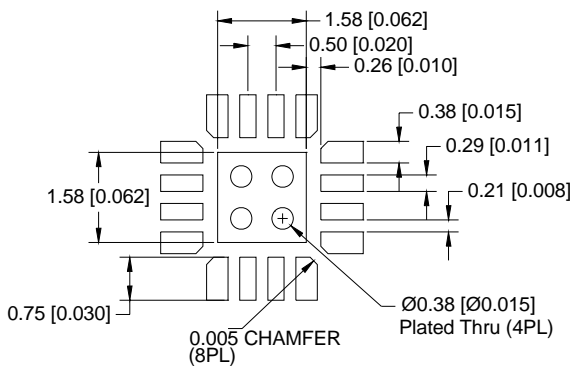

Recommended PCB Soldermask (SMOBC) for Land Pattern(dimensions in mm[in].):

