

## SMALL SMD HIGH - FREQUENCY CRYSTAL UNIT

## MA-306

- High-density mounting-type SMD.
- Excellent reliability and environment capability.
- Capable of covering a wide frequency range. ( from 17.734 MHz to 41 MHz)

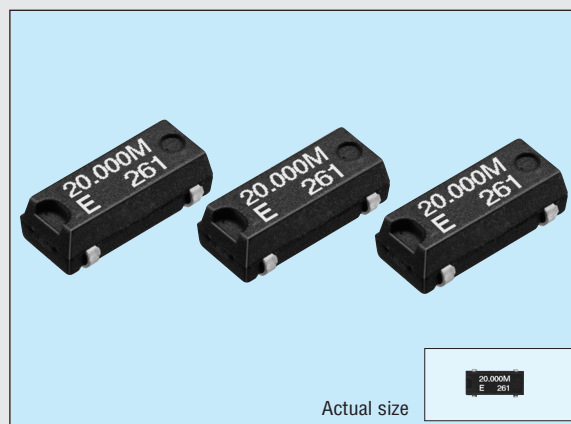

## ■ Specifications (characteristics)

Item	Symbol	Specifications	Remarks	
Nominal frequency	f	17.734 MHz to 41.000 MHz	Fundamental mode	
Temperature range	Storage temperature	T <sub>STG</sub>	-55 °C to +100 °C	Stored as bare product after unpacking
	Operating temperature	T <sub>OPR</sub>	-20 °C to +70 °C	
Drive level	Maximum drive level	GL	2 mW Max.	Only crystal oscillation is guaranteed
	Recommended drive level	DL	10 μW to 100 μW	
Soldering condition	T <sub>SOL</sub>	Twice at under +260 °C within 10 s or under +230 °C within 3 min.		
Frequency tolerance (standard)	Δf/f	±50 x 10 <sup>-6</sup>	T <sub>a</sub> = +25 °C ±3 °C	
Frequency temperature characteristics (standard)		±30 x 10 <sup>-6</sup>	-20 °C to +70 °C	
Load capacitance	C <sub>L</sub>	10 pF to ∞	Please specify	
Series resistance	R <sub>1</sub>	60 Ω Max.	-20 °C to +70 °C, DL=100 μW	
Shunt capacitance	C <sub>0</sub>	5 pF Max.		
Insulation resistance	IR	500 MΩ Min.		
Aging	fa	±5 x 10 <sup>-6</sup> / year Max.	T <sub>a</sub> =+25 °C ±3 °C, first year	
Shock resistance	S.R.	±10 x 10 <sup>-6</sup> Max.	Three drops on a hard board from 750 mm or excitation test with 29400 m/s <sup>2</sup> x 0.3 ms x 1/2 sine wave x 3 directions	

Metal may be exposed on the top of this product. This won't affect any quality, reliability or electrical spec.

## ■ External dimensions

(Unit: mm)

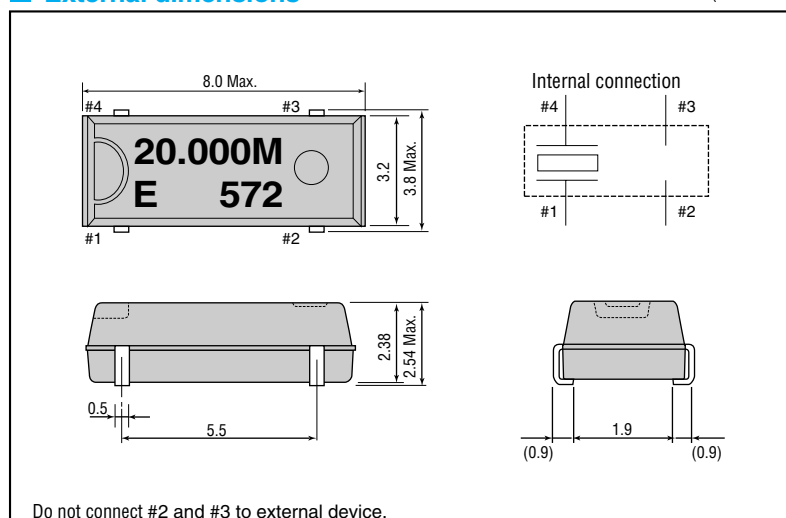

## ■ Recommended soldering pattern

(Unit: mm)

