

### OUTLINE OF SYSTEM

KIC9321F-005 is a C-MOS LSI designed for a FM/MW/LW radio of a PLL frequency synthesizer system corresponded to the requirement of the whole world.

This digital tuning system is optimum for such car audio equipment as three band radio with detachable panel.

- PLL + controller : KIC9321F-005 (QFP-60 PIN)
- LCD driver can control condition of key. : KIC9297F (QFP-60pin)
- Electronic volume : TEA6330T or TDA7313

### RECEIVING BAND

| AREA |    |    | BAND                                  | RECEIVING FREQ.<br>(Hz) | STEP<br>(Hz)                    | f <sub>ref</sub><br>(Hz) | IF<br>(Hz) |             |
|------|----|----|---------------------------------------|-------------------------|---------------------------------|--------------------------|------------|-------------|
| A2   | A1 | A0 |                                       |                         |                                 |                          |            |             |
| 0    | 0  | 0  | EUROPE                                | FM                      | 87.5 ~ 108.0 M                  | 50 k                     | 50 k       | + 10.7 M    |
|      |    |    |                                       | MW                      | 522 ~ 1620 k                    | 9 k                      | 9 k        | 450 / 459 k |
| 0    | 0  | 1  | EAST EUROPE                           | FM                      | 65.0 ~ 74.0 M<br>87.5 ~ 108.0 M | 50 k                     | 50 k       | + 10.7 M    |
|      |    |    |                                       | MW                      | 522 ~ 1620 k                    | 9 k                      | 9 k        | 450 / 459 k |
| 0    | 1  | 0  | USA 1                                 | FM                      | 87.5 ~ 107.9 M                  | 200 k                    | 50 k       | + 10.7 M    |
|      |    |    |                                       | MW                      | 520 ~ 1720 k                    | 10 k                     | 10 k       | + 450 k     |
| 0    | 1  | 1  | USA 2                                 | FM                      | 87.5 ~ 108.0 M                  | 100 k                    | 50 k       | + 10.7 M    |
|      |    |    |                                       | MW                      | 520 ~ 1720 k                    | 10 k                     | 10 k       | + 450 k     |
| 1    | 0  | 0  | LATIN AMERICA                         | FM                      | 87.5 ~ 108.0 M                  | 100 k                    | 50 k       | + 10.7 M    |
|      |    |    |                                       | MW                      | 530 ~ 1710 k                    | 10 k                     | 10 k       | + 450 k     |
| 1    | 0  | 1  | AUSTRALIA/<br>MIDDLE AND<br>NEAR EAST | FM                      | 87.5 ~ 108.0 M                  | 100 k                    | 50 k       | + 10.7 M    |
|      |    |    |                                       | MW                      | 531 ~ 1602 k                    | 9 k                      | 9 k        | + 450 k     |
| 1    | 1  | 0  | JAPAN                                 | FM                      | 76.0 ~ 90.0 M                   | 100 k                    | 50 k       | - 10.7 M    |
|      |    |    |                                       | MW                      | 522 ~ 1629 k                    | 9 k                      | 9 k        | + 450 k     |
| 1    | 1  | 1  | SOUTH AFRICA                          | FM                      | 87.5 ~ 108.0 M                  | 50 k                     | 50 k       | - 10.7 M    |
|      |    |    |                                       | MW                      | 531 ~ 1602 k                    | 9 k                      | 9 k        | + 450 k     |

| CODE |     | BAND       | RECEIVING FREQ<br>(Hz) | STEP<br>(Hz) | f <sub>ref</sub><br>(Hz) | IF<br>(Hz)          |
|------|-----|------------|------------------------|--------------|--------------------------|---------------------|
| LW1  | LW0 |            |                        |              |                          |                     |
| 0    | 0   | LW DISABLE | —                      |              |                          |                     |
| 0    | 1   | LW ENABLE  | 153 k ~ 279 k          | 1k           | 1k                       | +450k<br>/<br>+459k |
| 1    | 0   |            | 144 k ~ 288 k          |              |                          |                     |
| 1    | 1   |            | 146 k ~ 290 k          |              |                          |                     |

## OUTLINE OF FUNCTION

### (1) TUNING FUNCTION

- MANUAL TUNING (UP/DOWN)
- SEEK TUNING (UP/DOWN)
- SCAN TUNING (UP/DOWN)
- AUTO MEMORY TUNING
- PRESET MEMORY SCAN

### (2) MEMORY FUNCTION

- FM1/FM2/FM3 : MAX 18 STATIONS
- MW1/MW2 : MAX 12 STATIONS
- LW : 6 STATIONS
- VF : 6 STATIONS
- Maximum 42 stations in total.
- Each band has a last memory.

### (3) RADIO FUNCTION

- VF band (VF AUTO TUNING and DK STAND BY)
- LOC/DX control (AUTO LOCAL FUNCTION select possible)
- STEREO DISPLAY and MONO/STEREO select
- RADIO MONITOR FUNCTION

### (4) TAPE FUNCTION

- "TAPE" DISPLAY
- METAL/NORMAL select
- APS ON/OFF control
- DNR ON/OFF and B/C select
- TAPE RUNNING DISPLAY (|> / <| and |  |  |  |)

### (5) ELECTRONIC VOLUME / INPUT SELECT FUNCTION

- VOLUME / BASS / TREBLE / BALANCE / FADER
- LOUDNESS CONTROL
- RADIO / TAPE / CD INPUT
- MUTE FUNCTION
- TC4052BP/BF+TEA6330T or TDA7313 select able

### (6) CLOCK FUNCTION

- 12 hour display with "AM" and "PM" indicator or 24 hour display
- The colon display is possible to select flashing.

### (7) OTHER FUNCTION

- CD input and "CD" or "DISC" display.
- Burglary prevention alarm, and LED flashing display.

# KIC9321F-005

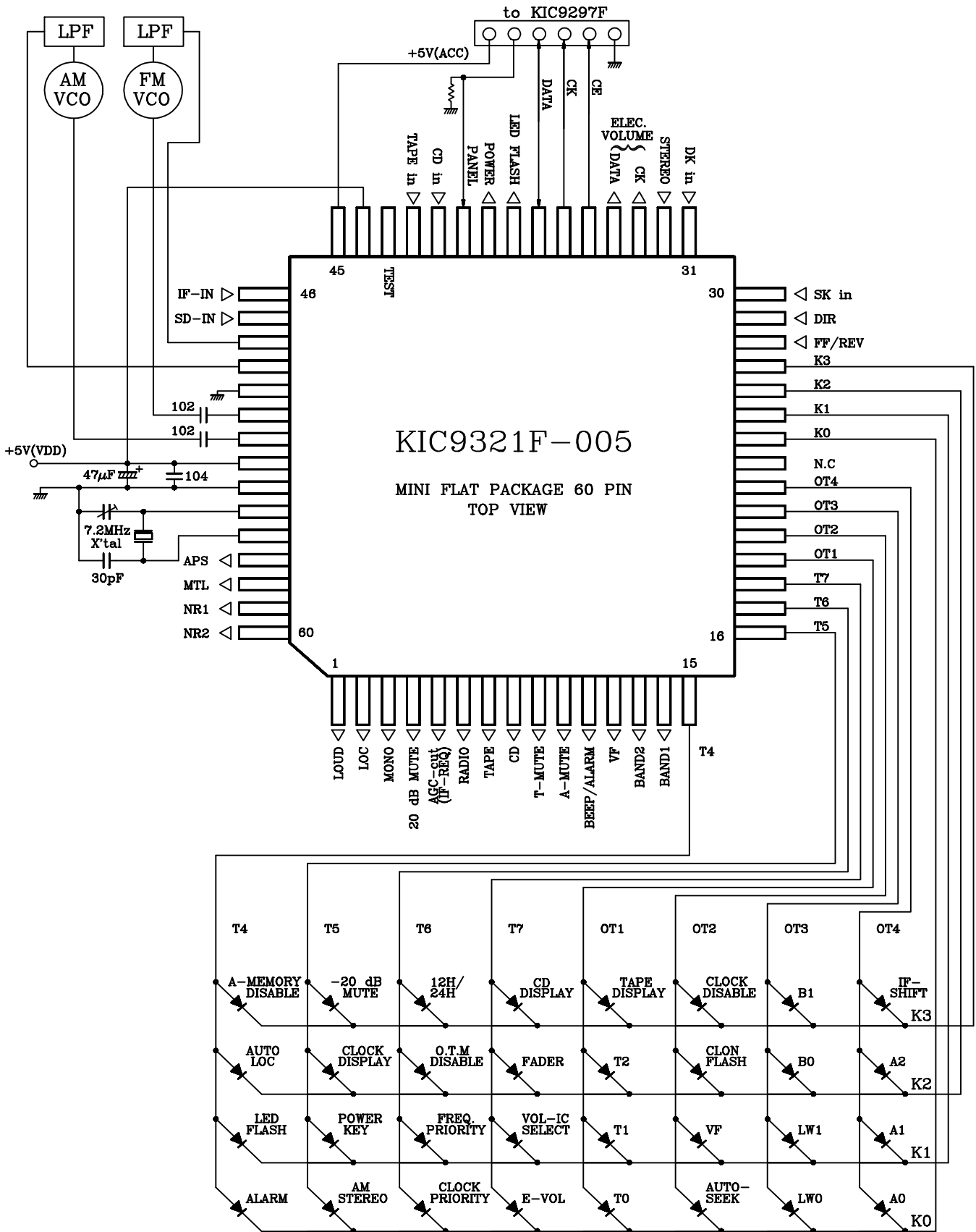

# KIC9321F-005

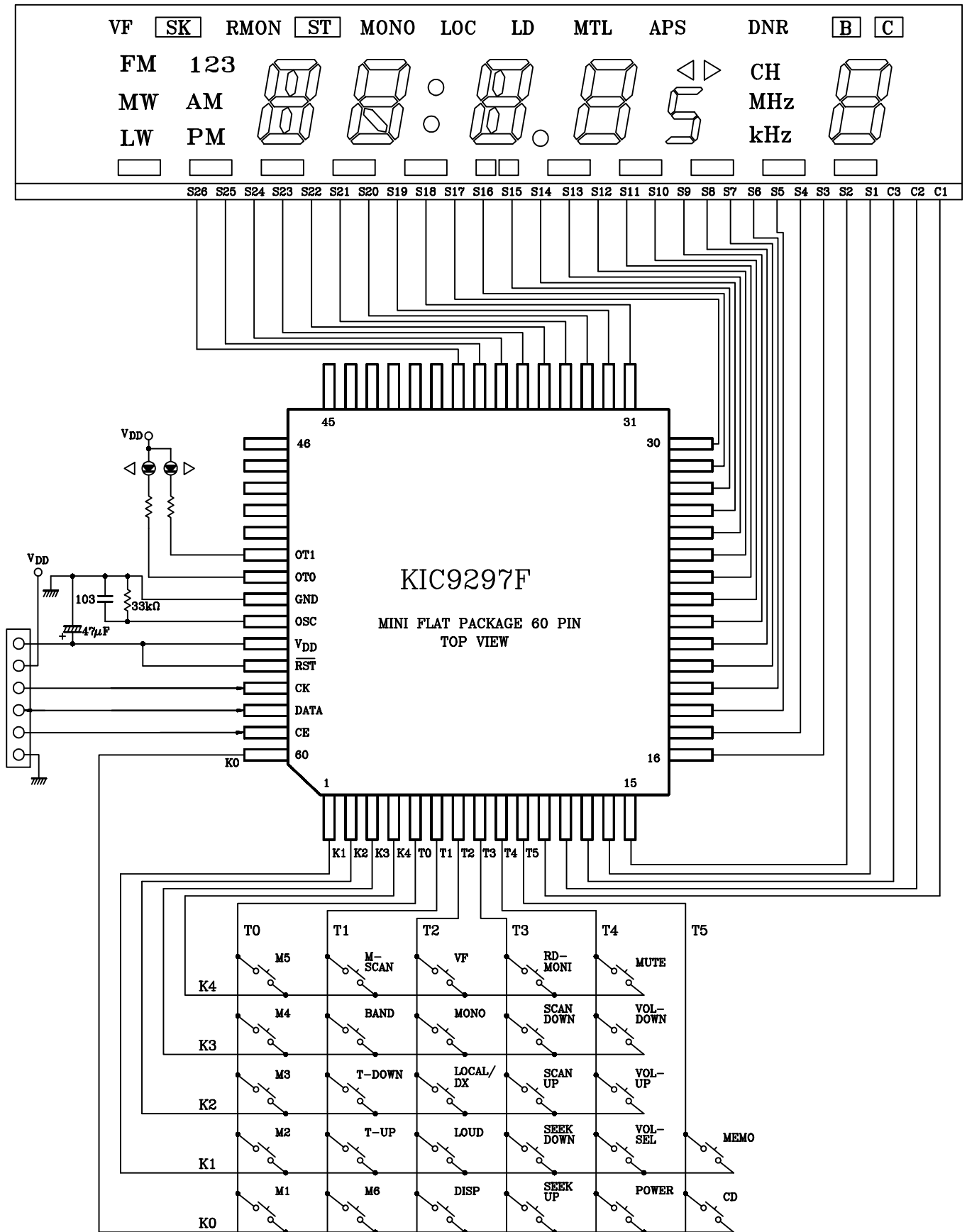

# KIC9321F-005

## KEY MATRIX (KIC9297F)

|    | K0                    | K1                 | K2                        | K3            | K4                        |
|----|-----------------------|--------------------|---------------------------|---------------|---------------------------|
| T0 | M1                    | M2                 | M3                        | M4<br>(APS)   | M5<br>(DNR/APS)           |
| T1 | M6<br>(METAL<br>/DNR) | T-UP<br>(MIN-ADJ.) | T-DOWN<br>(HOUR-<br>ADJ.) | BAND          | M-SCAN<br>(AUTO-<br>MEMO) |
| T2 | DISP                  | LOUD               | LOCAL<br>/<br>DX          | MONO          | VF                        |
| T3 | SEEK<br>-UP           | SEEK<br>-DOWN      | SCAN<br>-UP               | SCAN<br>-DOWN | RADIO<br>-MONI            |
| T4 | POWER                 | VOL<br>-SEL        | VOL<br>-UP                | VOL<br>-DOWN  | MUTE                      |
| T5 | CD                    | MEMORY             | -                         | -             | -                         |

## DIODE MATRIX (KIC9321F)

|     | K0                | K1                | K2                   | K3                  |
|-----|-------------------|-------------------|----------------------|---------------------|
| T4  | ALARM             | LED<br>FLASH      | AUTO<br>LOC          | A-MEMORY<br>disable |
| T5  | AM<br>STEREO      | POWER<br>KEY      | CLOCK<br>DISPLAY     | -20dB<br>MUTE       |
| T6  | CLOCK<br>PRIORITY | FREQ.<br>PRIORITY | * O. T. M<br>DISABLE | 12H<br>/<br>24H     |
| T7  | E-VOL             | VOL-IC<br>SELECT  | FADER                | CD<br>DISPLAY       |
| OT1 | T0                | T1                | T2                   | TAPE<br>DISPLAY     |
| OT2 | AUTO<br>-SEEK     | VF                | COLON<br>FLASH       | CLOCK<br>disable    |
| OT3 | LW0               | LW1               | B0                   | B1                  |
| OT4 | A0                | A1                | A2                   | IF<br>-SHIFT        |

\* O.T.M = One Touch Memory

# KIC9321F-005

## KEY MATRIX FUNCTION EXPLANATION

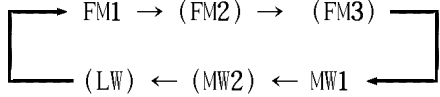
| SYMBOL            | EXPLANATION OF FUNCTION  |
|-------------------|--|
| M1~M3             | Calling and writing preset memory. ( 1~3ch )   |
| M4 (APS)          | In radio mode, calling and writing preset memory. (4~6ch)<br>These keys are act as the tape function key in tape mode.   |
| M5 (DNR/APS)      | In each function, the mark on LCD is indicated and corresponding put outputs "H" level.  |
| M6 (METAL/DNR)    | The tape function key is set by jumper of [T0] , [T1] , [T2].  |
| T-UP (MIN/ADJ)    | The receiving frequency steps up or down by pushing this key.<br>If key is pushed for more than 0.5 sec, frequency steps up continuously.<br>In case of AUTO SEEK function, it becomes SEEK tuning.  |
| T-DOWN (HOUR-ADJ) | During clock adjusting mode, hour or minute of clock is adjusted by pushing this key.  |
| BAND              | Changing the receiving band cyclically.<br>Every pushing of this key, the band is changed as shown below.<br>   |
| M-SCAN (A-MEMO)   | The MEMORY SCAN function is started by pushing this key for less than 2 sec.<br>The frequency written in memory is called in order.<br>The station will be received for 5 sec.<br>If this key pushed for more than 2sec, the AUTO MEMORY turning is started.<br>The search turning is started from current frequency, and first cycle is execute at local mode, then the frequency is written in memory, if the station can be received at frequency.<br>If the station can not be received at, second cycle is started DX mode. |
| DISPLAY           | Changing displays of clock, frequency, or CD/TAPE.<br>This function is invalid in clock disable mode.  |
| LOUD              | Used for turning ON/OFF of LOUDNESS.<br>"H" is outputted from LOUDNESS output and the "LD" mark on LCD is indicated, when the LOUDNESS function turn ON.<br>And electronic volume IC is controlled.  |
| LOCAL /DX         | Used for changing LOCAL/DX in radio mode.<br>The local output outputs "H" during auto turning, and the LOC mark on LCD is indicated, when the LOCAL is selected.<br>This function is invalid in auto LOCAL mode.   |

# KIC9321F-005

| SYMBOL          | EXPLANATION OF FUNCTION  |
|-----------------|--|
| MONO            | <p>Changing STEREO/MONO in radio mode.<br/>                     The MONO output outputs "H", and the "MONO" mark on LCD is indicated, when MONO is selected.<br/>                     This function is valid in AM band when AM stereo mode is selected.</p>   |
| VF              | <p>Changing receiving band to VF(SDK) band.<br/>                     In VF band, the "VF" mark and the "FM" mark on LCD is indicated and the VF terminal outputs "H".<br/>                     And it is necessary that the SK input is "H" with the SD input or IF signal. for stopping of the auto tuning.<br/>                     The way of changing to the original band is to push the [VF] key or the [BAND] key.</p>  |
| SEEK<br>UP/DOWN | <p>Seek up/down tuning key.<br/>                     If the station is received, auto tuning is stopped.<br/>                     This function is invalid in auto seek mode.</p>  |
| SCAN<br>UP/DOWN | <p>Scan up/down tuning key.<br/>                     If the station is received, auto tuning is stopped for 5 sec.<br/>                     After 5 sec. auto tuning start again.</p>  |
| RADIO<br>-MONI  | <p>During CD/TAPE, radio monitor can be executed.<br/>                     All radio function is valid in radio monitor mode.<br/>                     Radio monitor is clear for pushing [RADIO MONITOR] key again.</p>   |
| POWER           | <p>Used for power ON/OFF.<br/>                     Every pushing of [POWER] key, power output is changed "H"/"L".<br/>                     This function is invalid when power diode jumper is "0".</p>  |
| VOL-SEL         | <p>Changing volume mode cyclically.<br/>                     If key is pushed, mode is changed as shown below.<br/>                     Each mode returns to volume mode.<br/>                     if [VOL-SEL] key, [VOL-UP] key or [VOL-DOWN] key is not push for 5 sec, and display returns to frequency, clock, CD or TAPE.<br/>                     in case of fader diode = "1"</p> <div style="text-align: center;"> <pre>                     graph LR                     VOLUME --&gt; BASS                     BASS --&gt; TREBLE                     TREBLE --&gt; BALANCE                     BALANCE --&gt; VOLUME                     </pre> </div> <p>in case of fader diode = "0"</p> <div style="text-align: center;"> <pre>                     graph LR                     VOLUME --&gt; BASS                     BASS --&gt; TREBLE                     TREBLE --&gt; BALANCE                     BALANCE --&gt; FADER                     FADER --&gt; VOLUME                     </pre> </div> |

# KIC9321F-005

| SYMBOL             | EXPLANATION OF FUNCTION   |            |           |
|--------------------|---|------------|-----------|
| VOL-UP<br>VOL-DOWN | Volume control key.   |            |           |
|                    | VOL-MODE  | VOL-UP     | VOL-DOWN  |
|                    | VOLUME  | UP         | DOWN      |
|                    | BASS  | BOOST      | CUT       |
|                    | TREBLE  |            |           |
|                    | BALANCE   | Lch-DOWN   | Rch-DOWN  |
|                    | FADER   | FRONT-DOWN | REAR-DOWN |
|                    |   |            |           |
| MUTE               | Use for turning ON/OFF of volume mute.<br>During volume mute, volume level indicator is flashed at 1 Hz.<br>The volume mute is released by pushing [MUTE], [VOL-SEL], [VOL-UP] key or [VOL-DOWN] key.   |            |           |
| CD                 | Use for turning ON/OFF of CD mode.<br>This function is valid when CD input is "H".<br>During CD mode, display is indicated "CD" mark or "DISC" mark on LCD, and input selector is changed to CD input.  |            |           |
| MEMORY             | When frequency is displayed, this key is used for setting of memory writing enable state.<br>When clock is displayed, this key is used for setting of the clock adjusting enable state.<br>Each enable state is clear after 5 sec, when the designated is not push for 5 sec.<br>In case of O.T.M DISABLE jumper = "1", this function is valid. |            |           |









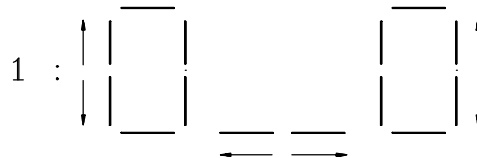

# KIC9321F-005

DIODE MATRIX FUNCTION EXPLAIN (1 : diode set , 0 : diode not set)

| SYMBOL  | EXPLANATION OF FUNCTION   |                 |                |                         |                              |       |
|---|---|-----------------|----------------|-------------------------|------------------------------|-------|
| A0, A1, A2<br>LW0, LW1                                  | Setting the area of receiving station.<br>Refer to receiving frequency list.  |                 |                |                         |                              |       |
| IF-SHIFT  | Select IF of AM band.<br>0 : MW/LW-IF = 450kHz<br>1 : MW/LW-IF = 459kHz   |                 |                |                         |                              |       |
| B0, B1  | Setting the number of memory bank.  |                 |                |                         |                              |       |
|   | B1  | B0              | FM             | MW                      |                              |       |
|   | 0   | 0               | FM 1 - 2 - 3   | MW 1-2                  |                              |       |
|   | 0   | 1               | FM 1 - 2 - 3   | MW 1                    |                              |       |
|   | 1   | 0               | FM 1 - 2       | MW 1                    |                              |       |
|   | 1   | 1               | FM1            | MW 1                    |                              |       |
| AUTO<br>SEEK  | The function of key is set by this jumper.<br>0 : If key is pushed for more than 0.5 sec, frequency step up or down continuously.<br>1 : If key is pushed for more than 0.5 sec, SEEK is start. |                 |                |                         |                              |       |
| VF  | Use for setting action of VF (SDK.)<br>0 : VF (SDK) is disabled. ([VF] key is invalid.)<br>1 : VF (SDK) is enabled.   |                 |                |                         |                              |       |
| CLOCK<br>DISABLE<br><br>12H / 24H<br><br>COLON<br>FLASH | Setting action of clock.  |                 |                |                         |                              |       |
|   | CLOCK<br>DISABLE  | 12H<br>/<br>24H | COLON<br>FLASH | CLOCK ACTION            |                              |       |
|   | 1   | -               | -              | CLOCK DISABLE           |                              |       |
|   | 0   | 0               | 0              | 12H CLOCK               | COLON : flashing at 1Hz rate |       |
|   |   |                 | 1              |                         | COLON : always lighting      |       |
|   | 0   | 1               | 0              | 24H CLOCK               | COLON : flashing at 1Hz rate |       |
| 1   |   |                 |                | COLON : always lighting |                              |       |
| T0<br><br>T1<br><br>T2                                  | Setting action of tape function.  |                 |                |                         |                              |       |
|   | T2  | T1              | T0             | M4                      | M5                           | M6    |
|   | 0   | 0               | 0              | tape function disable   |                              |       |
|   | 0   | 0               | 1              | -                       | -                            | METAL |
|   | 0   | 1               | 0              | -                       | -                            | DNR B |
|   | 0   | 1               | 1              | -                       | DNR B                        | METAL |
|   | 1   | 0               | 0              | -                       | APS                          | METAL |
|   | 1   | 0               | 1              | -                       | DNR B, C                     | METAL |
|   | 1   | 1               | 0              | APS                     | DNR B                        | METAL |
|   | 1   | 1               | 1              | APS                     | DNR B, C                     | METAL |

# KIC9321F-005

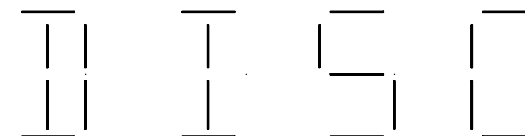
| SYMBOL  | EXPLANATION OF FUNCTION  |   |                |                            |   |   |   |   |   |   |   |   |  |                      |   |  |   |                |
|---|--|---|----------------|----------------------------|---|---|---|---|---|---|---|---|--|----------------------|---|--|---|----------------|
| TAPE<br>DISPLAY                                       | <p>Use for changing display of tape in tape mode.<br/>0 : &lt; &gt; (In case of FF/REV, flashing at 2Hz rate.)</p> <p>1 :  (In case of PLAY, the segment is shifted for 0.5 sec.<br/>In case of FF/REW, the segment is shifted for 0.10sec.)</p>  |   |                |                            |   |   |   |   |   |   |   |   |  |                      |   |  |   |                |
| E-VOL<br><br>VOL-IC<br>SELECT<br><br>FADER<br>DISABLE | <p>Setting action of electronic volume.</p> <table border="1" style="width: 100%; border-collapse: collapse;"> <thead> <tr> <th style="width: 15%;">E-VOL</th> <th style="width: 15%;">FADER</th> <th>ELECTRONIC VOLUME FUNCTION</th> </tr> </thead> <tbody> <tr> <td style="text-align: center;">0</td> <td style="text-align: center;">-</td> <td>ELECTRONIC VOLUME DISABLE</td> </tr> <tr> <td rowspan="2" style="text-align: center;">1</td> <td style="text-align: center;">0</td> <td>VOL→BASS→TREBLE→BALANCE<br/> </td> </tr> <tr> <td style="text-align: center;">1</td> <td>VOL→BASS→TREBLE→BALANCE<br/> </td> </tr> </tbody> </table> <table border="1" style="width: 100%; border-collapse: collapse;"> <thead> <tr> <th style="width: 30%;">VOL-IC SELECT</th> <th>ELECTRONIC VOLUME IC</th> </tr> </thead> <tbody> <tr> <td style="text-align: center;">0</td> <td>TEA6330T select</td> </tr> <tr> <td style="text-align: center;">1</td> <td>TDA7313 select</td> </tr> </tbody> </table> | E-VOL   | FADER          | ELECTRONIC VOLUME FUNCTION | 0 | - | ELECTRONIC VOLUME DISABLE                           | 1 | 0 | VOL→BASS→TREBLE→BALANCE<br> | 1 | VOL→BASS→TREBLE→BALANCE<br> | VOL-IC SELECT                              | ELECTRONIC VOLUME IC | 0 | TEA6330T select  | 1 | TDA7313 select |
| E-VOL   | FADER  | ELECTRONIC VOLUME FUNCTION  |                |                            |   |   |   |   |   |   |   |   |  |                      |   |  |   |                |
| 0   | -  | ELECTRONIC VOLUME DISABLE   |                |                            |   |   |   |   |   |   |   |   |  |                      |   |  |   |                |
| 1   | 0  | VOL→BASS→TREBLE→BALANCE<br> |                |                            |   |   |   |   |   |   |   |   |  |                      |   |  |   |                |
|   | 1  | VOL→BASS→TREBLE→BALANCE<br> |                |                            |   |   |   |   |   |   |   |   |  |                      |   |  |   |                |
| VOL-IC SELECT   | ELECTRONIC VOLUME IC   |   |                |                            |   |   |   |   |   |   |   |   |  |                      |   |  |   |                |
| 0   | TEA6330T select  |   |                |                            |   |   |   |   |   |   |   |   |  |                      |   |  |   |                |
| 1   | TDA7313 select   |   |                |                            |   |   |   |   |   |   |   |   |  |                      |   |  |   |                |
| CD<br>DISPLAY   | <p>Use for changing display of CD in CD mode.</p> <p>0 : </p> <p>1 : </p>   |   |                |                            |   |   |   |   |   |   |   |   |  |                      |   |  |   |                |
| CLOCK<br>PRIORITY<br><br>FREQ<br>PRIORITY             | <p>Setting the priority of display clock / frequency.</p> <table border="1" style="width: 100%; border-collapse: collapse;"> <thead> <tr> <th style="width: 15%;">FREQ. PRIORITY</th> <th style="width: 15%;">CLOCK PRIORITY</th> <th>DISPLAY FUNCTION</th> </tr> </thead> <tbody> <tr> <td style="text-align: center;">0</td> <td style="text-align: center;">0</td> <td>NO PRIORITY<br/>(Changing display by [display] key.)</td> </tr> <tr> <td style="text-align: center;">0</td> <td style="text-align: center;">1</td> <td>Display of clock is prior.</td> </tr> <tr> <td style="text-align: center;">1</td> <td style="text-align: center;">0</td> <td>Display of frequency, CD or TAPE is prior.</td> </tr> <tr> <td style="text-align: center;">1</td> <td style="text-align: center;">1</td> <td>RADIO MODE : Priority of frequency<br/>CD/TAPE MODE : Priority of clock</td> </tr> </tbody> </table>  | FREQ. PRIORITY  | CLOCK PRIORITY | DISPLAY FUNCTION           | 0 | 0 | NO PRIORITY<br>(Changing display by [display] key.) | 0 | 1 | Display of clock is prior.  | 1 | 0   | Display of frequency, CD or TAPE is prior. | 1                    | 1 | RADIO MODE : Priority of frequency<br>CD/TAPE MODE : Priority of clock |   |                |
| FREQ. PRIORITY  | CLOCK PRIORITY   | DISPLAY FUNCTION  |                |                            |   |   |   |   |   |   |   |   |  |                      |   |  |   |                |
| 0   | 0  | NO PRIORITY<br>(Changing display by [display] key.)   |                |                            |   |   |   |   |   |   |   |   |  |                      |   |  |   |                |
| 0   | 1  | Display of clock is prior.  |                |                            |   |   |   |   |   |   |   |   |  |                      |   |  |   |                |
| 1   | 0  | Display of frequency, CD or TAPE is prior.  |                |                            |   |   |   |   |   |   |   |   |  |                      |   |  |   |                |
| 1   | 1  | RADIO MODE : Priority of frequency<br>CD/TAPE MODE : Priority of clock  |                |                            |   |   |   |   |   |   |   |   |  |                      |   |  |   |                |

# KIC9321F-005

| SYMBOL             | EXPLANATION OF FUNCTION  |
|--------------------|--|
| O. T. M<br>DISABLE | Setting action of one touch memory.<br>0 : If preset memory key ([M1]-[M6]) is pushed for more than 2 sec continuously, the frequency is written is preset memory.<br>The clock adjustment is caused by [T-UP], [T-DOWN] key after pushing [DISPLAY] key for more than 2 sec. The hour of the clock is adjusted by the [T-UP] key, while the minute is adjusted by the [T-DOWN] key.<br><br>1 : After [MEMORY] key is pushed, if preset memory key is pushed within 5 seconds, the frequency is written.<br>The clock adjustment is caused by [T-UP], [T-DOWN] key after pushing [MEMORY] key. |
| AM<br>STEREO       | Setting action of [MONO] key and indicator of stereo.<br><br>0 : Valid at only FM band.<br>1 : Valid at FM band and AM band.   |
| POWER<br>KEY       | Setting to use [POWER] key.<br><br>0 : Turning ON/OFF is executed by ACC ( $\overline{\text{INH}}$ ) input Disability of [POWER] key.<br>1 : Turning ON/OFF is executed by [POWER] key.  |
| CLOCK<br>DISPLAY   | Setting display of clock, during power off.<br><br>0 : Clock display enabled, during power off.<br>1 : Clock display is disabled, during power off.  |
| -20dB<br>MUTE      | Setting [MUTE] key, function.<br><br>0 : A-MUTE terminal outputs "H" when [MUTE] key is pushed.<br>1 : The value of electronic volume is reduced 20dB and 20dB MUTE terminal outputs "H", when [MUTE] key is pushed.   |
| ALARM              | Setting the alarm output for forgetting to detach the panel during ACC OFF ( $\overline{\text{INH}}=\text{"L"}$ ).<br><br>0 : An alarm is not given.<br>1 : An alarm is given. But alarm is stopped when the PANEL IN terminal inputs "L" or 20 sec later.   |
| LED<br>FLASH       | If PANEL IN terminal inputs "L", the LED is flashed during ACC OFF ( $\overline{\text{INH}}=\text{"L"}$ ).<br><br>0 : Flashing LED is disabled.<br>1 : Flashing LED is enabled.  |

# KIC9321F-005

| SYMBOL              | EXPLANATION OF FUNCTION  |
|---------------------|--|
| AUTO<br>LOC.        | <p>Setting for automatically LOCAL/DX.</p> <p>0 : Changing function of LOCAL/DX is executed by pushing [LOCAL] key, Automatically LOCAL/DX is disabled.</p> <p>1 : The first cycle is start at local mode in the auto tuning (SEEK/SCAN), after key pushing, auto tuning is executed at DX mode. ([LOCAL] key is disabled.)</p> <p>(EXAMPLE)</p> <div style="text-align: center;"> <p>0 :</p> <p>[SEEK UP] KEY                      [SEEK UP] KEY</p> <p style="margin-left: 100px;">↓                      SEEK UP                      ↓</p> <p style="margin-left: 150px;">—————→ STOP</p> </div><br><div style="text-align: center;"> <p>1 :</p> <p>[SEEK UP] KEY    [SEEK UP] KEY    [SEEK UP] KEY</p> <p style="margin-left: 100px;">↓                      ↓    ↓</p> <p style="margin-left: 150px;">————→ SEEK UP (LOC) ———→ SEEK UP (DX) ———→ STOP</p> </div> |
| A-MEMORY<br>DISABLE | <p>Setting action of auto memory.</p> <p>0 : Auto memory is enabled.</p> <p>1 : Auto memory is disabled.</p>   |

# KIC9321F-005

## I/O PORTS

| PORT | NO. | NAME      | I/O | FUNCTION  | ACTIVE | CASE OF NOT USE |
|------|-----|-----------|-----|---|--------|-----------------|
| IN 1 | 47  | SD-IN     | IN  | A radio station detecting input.<br>The station is received when this input is "H".   | H      | GND             |
| IN 2 | 46  | IF-IN     | IN  | IF counter input.<br>This port is inputted more than 100mV <sub>rms</sub> in AC connection.   | -      | GND             |
| P1-1 | 42  | TAPE-IN   | IN  | TAPE DETECTING INPUT.   | H      | GND             |
| P1-2 | 41  | CD-IN     | IN  | CD DETECTING INPUT.<br>The action of CD key is active when CD input is "H".   | H      | GND             |
| P1-3 | 40  | PANEL     | IN  | DETECTION OF DETACHABLE PANEL.<br>(prevention of chattering for 0.2sec~0.5sec.)<br>IN="H", OUT="L"  | H      | V <sub>DD</sub> |
| P1-4 | 39  | POWER     | OUT | OUTPUT TO CONTROL THE POWER   | H      | OPEN            |
| P2-1 | 38  | LED FLASH | OUT | This function is active when $\overline{ACC}$ input is "L" and panel input is "L".<br>This output is repeated "H" state for 0.1sec and "L" state for 0.9 sec.<br>But this output is not used when jumper of LED FLASH is OFF. | H      | OPEN            |
| P2-2 | 37  | DATA-IN   | IN  | Communicate to KIC9297F LCD driver and key input.   | -      | -               |
|      |     | DATA-OUT  | OUT |   |        |                 |
| P2-3 | 36  | CK        | OUT | Using for KIC9297F.   | -      | -               |
| P2-4 | 35  | CE        | OUT | Communicate to KIC9297F.  | -      | -               |
| P3-1 | 34  | DATA      | OUT | Output to control TDA7313 electronic volume.  | -      | OPEN            |
| P3-2 | 33  | CK        | OUT | Output to control TEA6330T electronic volume.<br>DATA => SDA CK => SCL  |        | OPEN            |
| P3-3 | 32  | STEREO    | IN  | STEREO DETECTING INPUT.   | H      | GND             |

# KIC9321F-005

| PORT                 | NO.                  | NAME                     | I/O                  | FUNCTION   | ACTIVE   | CASE OF NOT USE |         |         |   |           |   |            |                |   |           |   |            |                |  |  |
|----------------------|----------------------|--------------------------|----------------------|--|--|-----------------|---------|---------|---|-----------|---|------------|----------------|---|-----------|---|------------|----------------|--|--|
| P4-1                 | 31                   | DK-IN                    | IN                   | DK DETECTING INPUT.<br>Audio input is changed from TAPE/CD mode to radio mode<br>When DK input is "H" in stand-by mode of VF band.   | H  | GND             |         |         |   |           |   |            |                |   |           |   |            |                |  |  |
| P4-2                 | 30                   | SK-IN                    | IN                   | SK DETECTING INPUT.<br>"SK" mark on LED is indicated when SK input is "H".<br>This input is used as signal to stop auto tuning in VF band.   | H  | GND             |         |         |   |           |   |            |                |   |           |   |            |                |  |  |
| P4-3                 | 29                   | DIR                      | IN                   | INPUT TO DETECTING DIRECTION OF TAPE.<br>• When [TAPE DISPLAY] key is OFF.   | -  | GND             |         |         |   |           |   |            |                |   |           |   |            |                |  |  |
| P4-4                 | 28                   | FF/REW                   | IN                   |  | -  | GND             |         |         |   |           |   |            |                |   |           |   |            |                |  |  |
|                      |                      |                          |                      |  | <table border="1" style="width: 100%; border-collapse: collapse;"> <thead> <tr> <th style="width: 10%;">DIR</th> <th style="width: 10%;">FF/REW</th> <th style="width: 80%;">DISPLAY</th> </tr> </thead> <tbody> <tr> <td rowspan="2" style="text-align: center;">L</td> <td style="text-align: center;">L</td> <td style="text-align: center;"> &gt;</td> </tr> <tr> <td style="text-align: center;">H</td> <td style="text-align: center;">" &gt;" 2Hz FLASH</td> </tr> <tr> <td rowspan="2" style="text-align: center;">H</td> <td style="text-align: center;">L</td> <td style="text-align: center;">&lt; </td> </tr> <tr> <td style="text-align: center;">H</td> <td style="text-align: center;">"&lt; " 2Hz FLASH</td> </tr> </tbody> </table> | DIR             | FF/REW  | DISPLAY | L | L         | > | H          | " >" 2Hz FLASH | H | L         | < | H          | "< " 2Hz FLASH |  |  |
| DIR                  | FF/REW               | DISPLAY                  |                      |  |  |                 |         |         |   |           |   |            |                |   |           |   |            |                |  |  |
| L                    | L                    | >                        |                      |  |  |                 |         |         |   |           |   |            |                |   |           |   |            |                |  |  |
|                      | H                    | " >" 2Hz FLASH           |                      |  |  |                 |         |         |   |           |   |            |                |   |           |   |            |                |  |  |
| H                    | L                    | <                        |                      |  |  |                 |         |         |   |           |   |            |                |   |           |   |            |                |  |  |
|                      | H                    | "< " 2Hz FLASH           |                      |  |  |                 |         |         |   |           |   |            |                |   |           |   |            |                |  |  |
|                      |                      |                          |                      | • When [TAPE DISPLAY] key is ON without clock priority diode jumper.   |  |                 |         |         |   |           |   |            |                |   |           |   |            |                |  |  |
|                      |                      |                          |                      | <table border="1" style="width: 100%; border-collapse: collapse;"> <thead> <tr> <th style="width: 10%;">DIR</th> <th style="width: 10%;">FF/REW</th> <th style="width: 80%;">DISPLAY</th> </tr> </thead> <tbody> <tr> <td rowspan="2" style="text-align: center;">L</td> <td style="text-align: center;">L</td> <td style="text-align: center;">                      (0.5 sec)                 </td> </tr> <tr> <td style="text-align: center;">H</td> <td style="text-align: center;">                      (0.10 sec)                 </td> </tr> <tr> <td rowspan="2" style="text-align: center;">H</td> <td style="text-align: center;">L</td> <td style="text-align: center;">                      (0.5 sec)                 </td> </tr> <tr> <td style="text-align: center;">H</td> <td style="text-align: center;">                      (0.10 sec)                 </td> </tr> </tbody> </table> | DIR  | FF/REW          | DISPLAY | L       | L | (0.5 sec) | H | (0.10 sec) | H              | L | (0.5 sec) | H | (0.10 sec) |                |  |  |
| DIR                  | FF/REW               | DISPLAY                  |                      |  |  |                 |         |         |   |           |   |            |                |   |           |   |            |                |  |  |
| L                    | L                    | (0.5 sec)                |                      |  |  |                 |         |         |   |           |   |            |                |   |           |   |            |                |  |  |
|                      | H                    | (0.10 sec)               |                      |  |  |                 |         |         |   |           |   |            |                |   |           |   |            |                |  |  |
| H                    | L                    | (0.5 sec)                |                      |  |  |                 |         |         |   |           |   |            |                |   |           |   |            |                |  |  |
|                      | H                    | (0.10 sec)               |                      |  |  |                 |         |         |   |           |   |            |                |   |           |   |            |                |  |  |
|                      |                      |                          |                      | • This function is actuated in tape mode.<br>(Note)<br><br>With clock priority jumper,  is not displayed.  |  |                 |         |         |   |           |   |            |                |   |           |   |            |                |  |  |
| K3<br>K2<br>K1<br>K0 | 27<br>26<br>25<br>24 | DI3<br>DI2<br>DI1<br>DI0 | IN<br>IN<br>IN<br>IN | DIODE MATRIX INPUT.  | H  | GND             |         |         |   |           |   |            |                |   |           |   |            |                |  |  |

# KIC9321F-005

| PORT   | NO.  | NAME   | I/O  | FUNCTION  | ACTIVE  | CASE OF NOT USE  |        |        |        |    |    |   |   |    |    |   |   |    |    |   |   |        |        |   |   |    |    |   |   |   |      |      |
|--|--|--|--|---|---|--|--------|--------|--------|----|----|---|---|----|----|---|---|----|----|---|---|--------|--------|---|---|----|----|---|---|---|------|------|
| OT 4<br>OT 3<br>OT 2<br>OT 1<br>T 7<br>T 6<br>T 5<br>T 4 | 22<br>21<br>20<br>19<br>18<br>17<br>16<br>15 | DS0<br>DS1<br>DS2<br>DS3<br>DS4<br>DS5<br>DS6<br>DS7 | OUT<br>OUT<br>OUT<br>OUT<br>OUT<br>OUT<br>OUT<br>OUT | Output to scan matrix of diode.   | H<br>H<br>H<br>H<br>H<br>H<br>H<br>H  | OPEN<br>OPEN<br>OPEN<br>OPEN<br>OPEN<br>OPEN<br>OPEN<br>OPEN |        |        |        |    |    |   |   |    |    |   |   |    |    |   |   |        |        |   |   |    |    |   |   |   |      |      |
| T3   | 14   | BAND 1   | OUT  |   | CHANGING BAND OUTPUT.   |  | OPEN   |        |        |    |    |   |   |    |    |   |   |    |    |   |   |        |        |   |   |    |    |   |   |   |      |      |
| T2   | 13   | BAND 2   | OUT  |   | <table border="1" style="margin: auto; border-collapse: collapse;"> <thead> <tr> <th style="width: 10%;">BAND</th> <th style="width: 15%;">BAND 1</th> <th style="width: 15%;">BAND 2</th> <th style="width: 15%;">VF</th> </tr> </thead> <tbody> <tr> <td>FM</td> <td>H</td> <td>L</td> <td>L</td> </tr> <tr> <td>MW</td> <td>L</td> <td>L</td> <td>L</td> </tr> <tr> <td>LW</td> <td>L</td> <td>H</td> <td>L</td> </tr> <tr> <td>FM (L)</td> <td>H</td> <td>H</td> <td>L</td> </tr> <tr> <td>VF</td> <td>H</td> <td>L</td> <td>H</td> </tr> </tbody> </table> |  | BAND   | BAND 1 | BAND 2 | VF | FM | H | L | L  | MW | L | L | L  | LW | L | H | L      | FM (L) | H | H | L  | VF | H | L | H | -    | OPEN |
| BAND   | BAND 1                                       | BAND 2   | VF   |   |   |  |        |        |        |    |    |   |   |    |    |   |   |    |    |   |   |        |        |   |   |    |    |   |   |   |      |      |
| FM   | H  | L  | L  |   |   |  |        |        |        |    |    |   |   |    |    |   |   |    |    |   |   |        |        |   |   |    |    |   |   |   |      |      |
| MW   | L  | L  | L  |   |   |  |        |        |        |    |    |   |   |    |    |   |   |    |    |   |   |        |        |   |   |    |    |   |   |   |      |      |
| LW   | L  | H  | L  |   |   |  |        |        |        |    |    |   |   |    |    |   |   |    |    |   |   |        |        |   |   |    |    |   |   |   |      |      |
| FM (L)   | H  | H  | L  |   |   |  |        |        |        |    |    |   |   |    |    |   |   |    |    |   |   |        |        |   |   |    |    |   |   |   |      |      |
| VF   | H  | L  | H  |   |   |  |        |        |        |    |    |   |   |    |    |   |   |    |    |   |   |        |        |   |   |    |    |   |   |   |      |      |
| T1   | 12   | VF   | OUT  | <table border="1" style="margin: auto; border-collapse: collapse;"> <thead> <tr> <th style="width: 10%;">BAND</th> <th style="width: 15%;">BAND 1</th> <th style="width: 15%;">BAND 2</th> <th style="width: 15%;">VF</th> </tr> </thead> <tbody> <tr> <td>FM</td> <td>H</td> <td>L</td> <td>L</td> </tr> <tr> <td>MW</td> <td>L</td> <td>L</td> <td>L</td> </tr> <tr> <td>LW</td> <td>L</td> <td>H</td> <td>L</td> </tr> <tr> <td>FM (L)</td> <td>H</td> <td>H</td> <td>L</td> </tr> <tr> <td>VF</td> <td>H</td> <td>L</td> <td>H</td> </tr> </tbody> </table> |   | BAND   | BAND 1 | BAND 2 | VF     | FM | H  | L | L | MW | L  | L | L | LW | L  | H | L | FM (L) | H      | H | L | VF | H  | L | H | - | OPEN |      |
| BAND   | BAND 1                                       | BAND 2   | VF   |   |   |  |        |        |        |    |    |   |   |    |    |   |   |    |    |   |   |        |        |   |   |    |    |   |   |   |      |      |
| FM   | H  | L  | L  |   |   |  |        |        |        |    |    |   |   |    |    |   |   |    |    |   |   |        |        |   |   |    |    |   |   |   |      |      |
| MW   | L  | L  | L  |   |   |  |        |        |        |    |    |   |   |    |    |   |   |    |    |   |   |        |        |   |   |    |    |   |   |   |      |      |
| LW   | L  | H  | L  |   |   |  |        |        |        |    |    |   |   |    |    |   |   |    |    |   |   |        |        |   |   |    |    |   |   |   |      |      |
| FM (L)   | H  | H  | L  |   |   |  |        |        |        |    |    |   |   |    |    |   |   |    |    |   |   |        |        |   |   |    |    |   |   |   |      |      |
| VF   | H  | L  | H  |   |   |  |        |        |        |    |    |   |   |    |    |   |   |    |    |   |   |        |        |   |   |    |    |   |   |   |      |      |
|  |  |  |  | • FM(L) = 65.0~74.0 MHz   |   |  |        |        |        |    |    |   |   |    |    |   |   |    |    |   |   |        |        |   |   |    |    |   |   |   |      |      |
| T 0  | 11   | BEEP<br><br>ALARM                                    | OUT<br><br>OUT                                       | OUTPUT BUZZER.<br><br>ALARM OUTPUT FOR FORGETTING TO DETACHABLE PANEL.<br>ALARM SEL = "1".<br>An alarm is given for 20 sec at $\overline{\text{ACC}} = \text{"L"}$ .<br>PANEL="H".  | H   | OPEN   |        |        |        |    |    |   |   |    |    |   |   |    |    |   |   |        |        |   |   |    |    |   |   |   |      |      |
| P5-1   | 57   | APS  | OUT  | Output to turning ON/OFF of searching music.  | H   | OPEN   |        |        |        |    |    |   |   |    |    |   |   |    |    |   |   |        |        |   |   |    |    |   |   |   |      |      |
| P5-2   | 58   | MTL  | OUT  | Output to charging metal/normal of tape function.   | H   | OPEN   |        |        |        |    |    |   |   |    |    |   |   |    |    |   |   |        |        |   |   |    |    |   |   |   |      |      |
| P5-3   | 59   | NR1  | OUT  | Output to charging B/C of DNR (DOLBY).  | H   | OPEN   |        |        |        |    |    |   |   |    |    |   |   |    |    |   |   |        |        |   |   |    |    |   |   |   |      |      |
| P5-4   | 60   | NR2  | OUT  | NR 1 output is B.<br>NR 2 output is C.  | H   | OPEN   |        |        |        |    |    |   |   |    |    |   |   |    |    |   |   |        |        |   |   |    |    |   |   |   |      |      |
| P6-1   | 1  | LUD  | OUT  | Output to control loudness.   | H   | OPEN   |        |        |        |    |    |   |   |    |    |   |   |    |    |   |   |        |        |   |   |    |    |   |   |   |      |      |
| P6-2   | 2  | LOC  | OUT  | Output to charging LOCAL/DX.<br>LOCAL = "H".<br>DX = "L".   | H   | OPEN   |        |        |        |    |    |   |   |    |    |   |   |    |    |   |   |        |        |   |   |    |    |   |   |   |      |      |
| P6-3   | 3  | MONO   | OUT  | Output to charging MONO/STEREO.<br>MONO = "H".<br>STEREO = "L".   | H   | OPEN   |        |        |        |    |    |   |   |    |    |   |   |    |    |   |   |        |        |   |   |    |    |   |   |   |      |      |
| P6-4   | 4  | 20 dB MUTE   | OUT  | -20dB MUTE OUTPUT.<br>This function is active, selecting -20dB mute jumper.   | H   | OPEN   |        |        |        |    |    |   |   |    |    |   |   |    |    |   |   |        |        |   |   |    |    |   |   |   |      |      |

# KIC9321F-005

| PORT                               | NO.   | NAME             | I/O | FUNCTION   | ACTIVE                             | CASE OF NOT USE |  |  |      |       |      |    |       |   |   |   |      |   |   |   |    |   |   |   |   |      |
|------------------------------------|-------|------------------|-----|--|------------------------------------|-----------------|--|--|------|-------|------|----|-------|---|---|---|------|---|---|---|----|---|---|---|---|------|
| P7-1                               | 5     | AGC-cut (IF-REQ) | OUT | "H" is outputted in searching action.<br>This function is used to control signal of IF count or cut action of AGC circuit.   | H                                  | OPEN            |  |  |      |       |      |    |       |   |   |   |      |   |   |   |    |   |   |   |   |      |
| P7-2                               | 6     | Radio            | OUT | <table border="1" style="width: 100%; border-collapse: collapse;"> <tr> <td colspan="4" style="text-align: center;">Output to changing signal of audio</td> </tr> <tr> <td style="text-align: center;">MODE</td> <td style="text-align: center;">RADIO</td> <td style="text-align: center;">TAPE</td> <td style="text-align: center;">CD</td> </tr> <tr> <td style="text-align: center;">RADIO</td> <td style="text-align: center;">H</td> <td style="text-align: center;">L</td> <td style="text-align: center;">L</td> </tr> <tr> <td style="text-align: center;">TAPE</td> <td style="text-align: center;">L</td> <td style="text-align: center;">H</td> <td style="text-align: center;">L</td> </tr> <tr> <td style="text-align: center;">CD</td> <td style="text-align: center;">L</td> <td style="text-align: center;">L</td> <td style="text-align: center;">H</td> </tr> </table> <p>This output of MODE 1/2 is used to control KIC4052BP/F analogue switch.</p> | Output to changing signal of audio |                 |  |  | MODE | RADIO | TAPE | CD | RADIO | H | L | L | TAPE | L | H | L | CD | L | L | H | - | OPEN |
| Output to changing signal of audio |       |                  |     |  |                                    |                 |  |  |      |       |      |    |       |   |   |   |      |   |   |   |    |   |   |   |   |      |
| MODE                               | RADIO | TAPE             | CD  |  |                                    |                 |  |  |      |       |      |    |       |   |   |   |      |   |   |   |    |   |   |   |   |      |
| RADIO                              | H     | L                | L   |  |                                    |                 |  |  |      |       |      |    |       |   |   |   |      |   |   |   |    |   |   |   |   |      |
| TAPE                               | L     | H                | L   |  |                                    |                 |  |  |      |       |      |    |       |   |   |   |      |   |   |   |    |   |   |   |   |      |
| CD                                 | L     | L                | H   |  |                                    |                 |  |  |      |       |      |    |       |   |   |   |      |   |   |   |    |   |   |   |   |      |
| P7-3                               | 7     | TAPE             | OUT | -  | OPEN                               |                 |  |  |      |       |      |    |       |   |   |   |      |   |   |   |    |   |   |   |   |      |
| P7-4                               | 8     | CD               | OUT | -  | OPEN                               |                 |  |  |      |       |      |    |       |   |   |   |      |   |   |   |    |   |   |   |   |      |
| P8-1                               | 9     | T-MUTE           | OUT | TUNING MUTE INPUT.<br>During tuning, this port is "H" for a certain period of time.  | H                                  | OPEN            |  |  |      |       |      |    |       |   |   |   |      |   |   |   |    |   |   |   |   |      |
| P8-2                               | 10    | A-MUTE           | OUT | AUDIO MUTE INPUT.<br>When the function is changing, this port is "H" for a certain period of time.   | H                                  | OPEN            |  |  |      |       |      |    |       |   |   |   |      |   |   |   |    |   |   |   |   |      |



# KIC9321F-005

KIC9321F-005 LCD map

| SYMBOL | PIN NO. | SEGMENT NAME |      |      | FUNCTION  |
|--------|---------|--------------|------|------|---|
|        |         | COM1         | COM2 | COM3 |   |
| COM 1  | 11      | COM 1        | -    | -    | COMMON 1  |
| COM 2  | 12      | -            | COM2 | -    | COMMON 2  |
| COM 3  | 13      | -            | -    | COM3 | COMMON 3  |
| s 1    | 14      | LW           | MW   | FM   | FM : FM band<br>MW : MW band<br>LW : LW band              |
| s 2    | 15      | PM           | AM   | VF   | VF : VF band<br>1-2-3 : bank1 bank2 bank3                 |
| s 3    | 16      | 1e           | 1f   | 1    | AM : AM (clock)<br>PM : PM (clock)                        |
| s 4    | 17      | 1g           | 1a   | 2    | 1a-e-f-g : 1602 / 12:00                                   |
| s 5    | 18      | 1hi          | 1b   | 3    | SK : SK DISPLAY<br>RMON : RADIO MONITOR<br>ST : STEREO    |
| s 6    | 19      | 1d           | 1c   | SK   | 1-b-c-d : 1602 / 12:00                                    |
| s 7    | 20      | 2e           | 2f   | RMON | 1h-i : 1602 / 12:00                                       |
| s 8    | 21      | 2g           | 2a   | ST   | 2a-e-f-g : 1602 / 12:00                                   |
| s 9    | 22      | 2j           | 2b   | MONO | MONO : MONO<br>LOC : LOCAL<br>LD : LOUDNESS               |
| s 10   | 23      | 2d           | 2c   | :    | : : COLON<br>· : · DISPLAY                                |
| s 11   | 24      | 3e           | 3f   | LOC  | 2b-c-d-j : 1602 / 12:00                                   |
| s 12   | 25      | 3g           | 3a   | LD   | 3a-e-f-g : 1602 / 12:00                                   |
| s 13   | 26      | 3hi          | 3b   | ·    | MTL : METAL<br>APS : APS DISPLAY<br><  : <  DISPLAY       |
| s 14   | 27      | 3d           | 3c   | MTL  | 3b-c-d : 1602 / 12:00                                     |
| s 15   | 28      | 4e           | 4f   | APS  | 3h-i : 1602 / 12:00                                       |
| s 16   | 29      | 4g           | 4a   | <    | 4a-e-f-g : 1602 / 12:00                                   |
| s 17   | 30      | 5            | 4b   | >    | kHz : kHz DISPLAY<br>MHz : MHz DISPLAY<br>CH : CH DISPLAY |
| s 18   | 31      | 4d           | 4c   | kHz  | > :  > DISPLAY<br>5 : 107.75                              |
| s 19   | 32      | 5e           | 5f   | MHz  | 4b-c-d : 1602 / 12:00                                     |
| s 20   | 33      | 5g           | 5a   | CH   | 5a-e-f-g : ch 8   |
| s 21   | 34      | B            | 5b   | DNR  | DNR : DNR DISPLAY<br>5b-c-d : ch 8                        |
| s 22   | 35      | 5d           | 5c   | C    | B : B mark<br>C : C mark                                  |
| s 23   | 36      | (K)          | (J)  | -    | (A)(B)(C) : VOLUME LEVEL                                  |
| s 24   | 37      | (G)          | (I)  | (H)  | (D)(E)(F) : VOLUME LEVEL                                  |
| s 25   | 38      | (A)          | (B)  | (C)  | (G)(H)(I) : VOLUME LEVEL                                  |
| s 26   | 39      | (F)          | (E)  | (D)  | (J)(K) : VOLUME LEVEL                                     |
| s 27   | 40      | -            | -    | -    |   |
| s 28   | 41      | -            | -    | -    |   |

# KIC9321F-005

KIC9321F-005 LCD map

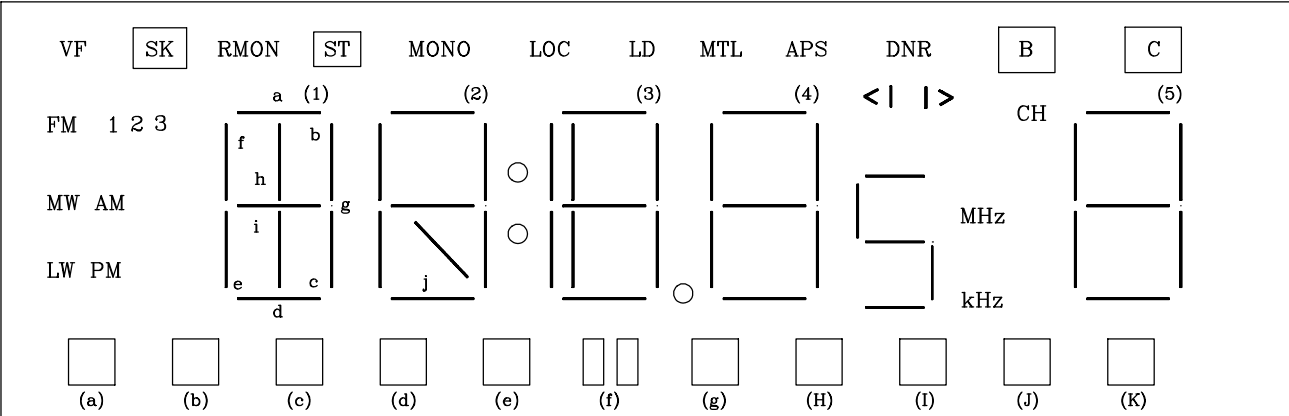

## THE EXPLANATION OF FUNCTIONS

| MENU  | PAGE           |
|---|----------------|
| 1. BAND CHANGE .....  | 20             |
| 2. MANUAL TUNING .....  | 21             |
| 3. SEEK TUNING .....  | 22             |
| 4. SCAN TUNING .....  | 23             |
| 5. AUTO STOP AND IF COUNTER .....   | 24             |
| 6. PRESET MEMORY .....  | 25             |
| 7. MEMORY SCAN .....  | 26             |
| 8. AUTO MEMORY .....  | 27             |
| 9. FUNCTION CHANGE .....  | 28             |
| 10. ELECTRONIC VOLUME CONTROL .....                                       | 29, 30, 31     |
| 11. CLOCK .....   | 32, 33         |
| 12. BUZZER OUT .....  | 33             |
| 13. SDK FUNCTION .....  | 34             |
| 14. RADIO MONITOR .....   | 35             |
| 15. POWER OUT .....   | 35             |
| 16. TRACKING DATA .....   | 36, 37         |
| 17. THE EXPLANATION OF DISTURBANCE WHILE<br>FUNCTIONS ARE EXECUTING ..... | 38, 39, 40, 41 |

# KIC9321F-005

## BAND CHANGE

### 1. PRINCIPAL FUNCTION

Changing the receiving band

### 2. KEY TO BE USED

[BAND] key, B0, B1 diode.

### 3. FUNCTIONS

- a. Every pushing the [BAND] key, the receiving band is changed cyclically.  
The order of changing the band is as shown below.

- In case of LW enable

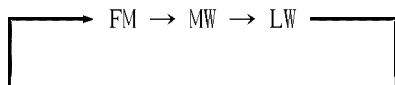

- In case of LW disable

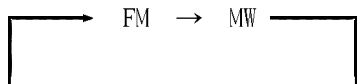

- b. In changing band, A-MUTE terminal outputs "H" for 1000mS.

- c. In setting B0, B1, LW0 or LW1 jumper,  
the composition of changing the band is as shown below.

| B1 | B0 | BAND                    |
|----|----|-------------------------|
| 0  | 0  | FM1, FM2, FM3, MW1, MW2 |
| 0  | 1  | FM1, FM2, FM3, MW1      |
| 1  | 0  | FM1, FM2, MW1           |
| 1  | 1  | FM1, MW1                |

| CODE |     | BAND       | RECEIVING FREQ<br>(Hz) |
|------|-----|------------|------------------------|
| LW1  | LW0 |            |                        |
| 0    | 0   | LW DISABLE | -                      |
| 0    | 1   | LW ENABLE  | 153k ~ 279k            |
| 1    | 0   |            | 144k ~ 288k            |
| 1    | 1   |            | 146k ~ 290k            |

- d. In changing band, band terminal outputs as shown below.

| BAND   | BAND 1 | BAND 2 | VF |
|--------|--------|--------|----|
| FM     | H      | L      | L  |
| MW     | L      | L      | L  |
| LW     | L      | H      | L  |
| FM (L) | H      | H      | L  |
| VF     | H      | L      | H  |

- FM (L) = 65.0 ~ 74.0 MHz

## MANUAL TUNING

### 1. PRINCIPAL FUNCTION

The 1 step / 1 push tuning continuous tuning by pushing the (T-UP/MIN-ADJ.) or (T-DOWN/HOUR-ADJ.) key.

### 2. KEY TO BE USED

(T-UP/MIN-ADJ.) key, (T-DOWN/HOUR-ADJ.) key, AUTO-SEEK diode.

### 3. FUNCTIONS

#### (1) In case of AUTO SEEK disable (AUTO-SEEK diode = 0)

- a. The 1 step / 1 push tuning is executed by pushing the (T-UP/MIN-ADJ.) or (T-DOWN/HOUR-ADJ.) key for less than 500mS.
- b. When the (T-UP/MIN-ADJ.) or (T-DOWN/HOUR-ADJ.) key for more than 500mS, the continuous tuning is started.  
And in case of the [T-UP/MIN-ADJ] or [T-DOWN/HOUR-ADJ] key released, the continuous tuning is stopped.
- c. In pushing the [T-UP/MIN-ADJ] or [T-DOWN/HOUR-ADJ] key, other key is disable.
- d. When the frequency reached the band edge, it goes to the opposite side.  
And the continuous tuning is stopped for 500 mS.
- e. The speed of running in the continuous tuning is 50 mS / step.
- f. When [T-UP/MIN-ADJ] or [T-DOWN/HOUR-ADJ.] key is pushed, A-MUTE terminal outputs "H" for 600mS.  
And when the frequency reached the band edge, A-MUTE terminal outputs "H" for 1000 mS.

#### (2) In case of AUTO SEEK enable (AUTO-SEEK diode=1)

- a. When the [T-UP/MIN-ADJ] or [T-DOWN/HOUR-ADJ] key for more than 500 mS, the seek tuning is started.
- b. When the frequency reached the band edge, it goes to the opposite side.  
And the continuous tuning is stopped for 500 mS.
- c. The speed of running in the seek tuning is 50 mS/step.

## SEEK TUNING

### 1. PRINCIPAL FUNCTION

The seek tuning by pushing the (SEEK-UP) or (SEEK-DOWN) key.

### 2. KEY TO BE USED

(SEEK-UP) key, (SEEK-DOWN) key.

### 3. FUNCTIONS

- a. The seek tuning function is started by pushing the [SEEK-UP] or [SEEK-DOWN] key.
- b. In case of AUTO-SEEK diode is set, the [SEEK-UP] or [SEEK-DOWN] key is disable.
- c. The seek tuning is stopped, if the stop signal is detected on the SD INPUT (IN1) or the intermediate frequency is counted by the IF counter.
- d. When the [SEEK-UP] or [SEEK-DOWN] key is pushed continuous, the seek tuning is not stopped if the station can be received.
- e. When the receiving frequency reached the band edge, it goes to the opposite side.  
And the seek tuning stopped for 500 mS.
- f. The speed of the seek tuning is 50 mS/step.

## SCAN TUNING

### 1. PRINCIPAL FUNCTION

The scan tuning by pushing the [SCAN-UP] or [SCAN-DOWN] key.

### 2. KEY TO BE USED

[SCAN-UP] key, [SCAN-DOWN] key.

### 3. FUNCTIONS

- a. The scan tuning function is started by pushing the [SCAN-UP] or [SCAN-DOWN] key.
- b. The scan tuning is stopped for 5 sec, if the stop signal is detected on the SD INPUT or the intermediate frequency is counted by the IF counter.
- c. When the [SCAN-UP] or [SCAN-DOWN] key is pushing continous, the scan tuning is not stopped if the station is received.
- d. When the receiving frequency is reached the band edge, it goes to the opposite side. And the scan tuning is stopped for 500 mS.
- e. The speed of the scan tuning is 50 mS/step.

## LOCAL / DX MODE

### 1. PRINCIPAL FUNCTION

Changing LOCAL and DX function.

### 2. KEY TO BE USED

[SEEK-UP] key, [SEEK-DOWN] key, [SCAN-UP] key, [SCAN-DOWN] key, [LOCAL/DX] key, AUTO LOC diode.

### 3. FUNCTIONS

- a. When the seek tuning or the scan tuning is running, LOCAL terminal outputs "H" in LOCAL mode.
- b. In case of AUTO LOC diode is not set, LOCAL/DX mode is changed cyclically by pushing the [LOCAL/DX] key.
- c. In case of AUTO LOC diode is set, LOCAL/DX mode is changed by the second pushing [SEEK-UP/DOWN] key or [SCAN-UP/DOWN] key. When AUTO LOC diode is not set, [LOCAL/DX] key is invalid.
- d. The direction of tuning is changed by pushing [DOWN] key in up mode, by pushing [UP] key in down mode.

With AUTO LOC diode

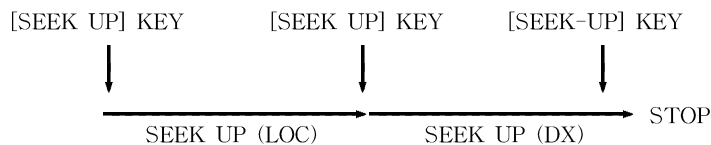

Without AUTO LOC diode

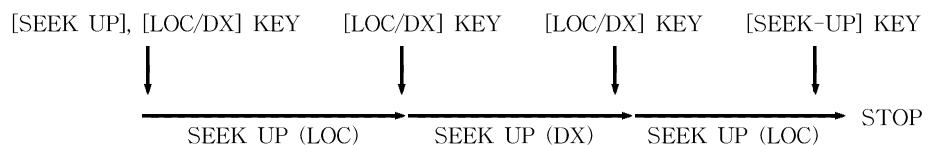

# KIC9321F-005

## AUTO STOP AND IF COUNTER

### 1. PRINCIPAL FUNCTION

Detecting SD signal or counting IF.

### 2. I/O TO BE USED

IF INPUT, SD INPUT

### 3. FUNCTIONS

- a. The intermediate frequency (IF) is counted as condition of stopping for the auto memory, the seek/scan tuning and the memory scan.
- b. It is judged to be station when the intermediate frequency (IF) is counted, or SD input inputs stop signal.
- c. The intermediate frequency (IF) is inputted on IF input and is counted.  
 If the IF is counted in wide range, after 100mS the IF is counted on same receiving frequency again.  
 If the IF counted is in narrow range, it is judged to be the station.  
 It is judged to be the station, when SD input inputs "H".  
 It is judged to be the station in VF band, when the SK input inputs "H" with the condition as shown above.

#### ① In case of IF check

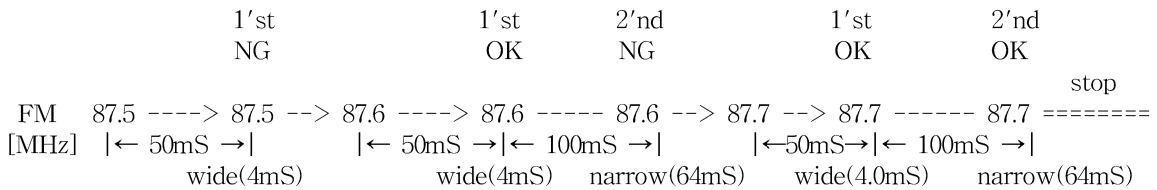

#### ② In case of IF check (VF band)

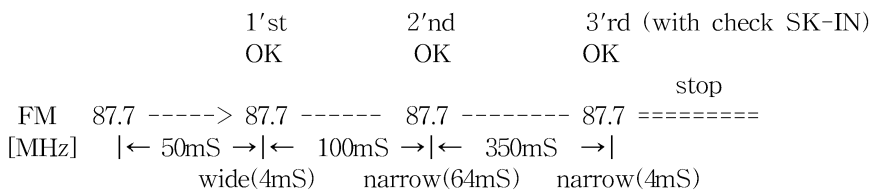

#### d. Setting value of IF check

| BAND | REFERENCE FREQUENCY [Hz] | First counting (WIDE)        |                | Second counting (NARROW)     |                |
|------|--------------------------|------------------------------|----------------|------------------------------|----------------|
|      |                          | DETECTED WIDTH [Hz]          | GATE TIME [mS] | DETECTED WIDTH [Hz]          | GATE TIME [mS] |
| MW   | 9 k                      | 450k ± 12.0k                 | 4.0            | 450k ± 3.0k                  | 4.0            |
|      | 10 k                     | / 459k ± 12.0k               |                | / 459k ± 3.0k                |                |
| FM   | 50 k                     | 10.7M ± 80k                  | 4.0            | 10.7M ± 15k                  | 64.0           |
| LW   | 1 k                      | 450k ± 2.4k<br>/ 459k ± 2.4k | 4.0            | 450k ± 0.6k<br>/ 459k ± 0.6k | 4.0            |



## PRESET MEMORY

### 1. PRINCIPAL FUNCTION

Calling and writing in the preset memory.

### 2. KEY TO BE USED

(M1)~[M6(METAL/DNR)] key, [MEMORY] key.

### 3. FUNCTIONS

#### (1) In case of ONE TOUCH MEMORY disable (O.T.M DISABLE diode=1)

- a. There are 6 stations for each band in preset memory.
- b. In case of calling the preset memory.
  - The receiving frequency written in the memory is called by the pushing the [M1]~[M6(METAL/DNR)] key.
  - And T-MUTE output outputs "H" for 600mS.
- c. In case of writing in preset memory
  - If the [MEMORY] key is pushed in radio, it is the memory writing enable state for 5 sec.
  - The "MEMO" mark flashes at 1 Hz rate in the memory writing enable state.
  - If the [M1]~[M6(METAL/DNR)] key is pushed in the memory writing enable state, the receiving frequency is written in the memory of the key pushed.
  - If the receiving frequency is written in the preset memory, the "MEMO" mark is indicated and the memory number of the key pushed is indicated on LCD.
- d. If the [MEMORY] key is pushed in the memory writing enable state, the state is released.
- e. After 5 sec from setting of the memory writing enable state, the state is released.
- f. It is disable to call the memory, or to write the memory in power off. The [MEMORY] key is used as adjust the clock.

#### (2) In case of ONE TOUCH MEMORY enable (O.T.M DISABLE diode=0)

- a. There are 6 stations for each band in preset memory.
- b. In case of calling the preset memory
  - The receiving frequency written in the memory is called by the pushing the [M1]~[M6(METAL/DNR)] key for less than 2 sec.
- c. In case of writing in preset memory
  - If the [M1]~[M6(METAL/DNR)] key is pushed for more than 2 sec. the receiving frequency is written in the memory of the key pushed.
- d. It is disable to call the memory, or the write the memory in power off. The [MEMORY] key is used as adjust the clock.

## MEMORY SCAN

### 1. PRINCIPAL FUNCTION

Calling the preset memory in order.

### 2. KEY TO BE USED

[MEMORY-SCAN] key

### 3. FUNCTIONS

a. When the [MEMORY-SCAN] key is pushed for less than 2 sec, the memory scan function is started from next memory number of receiving memory number. If the preset memory is not called, the memory scan function is started from ch 1. In the memory scan, the frequency written in the memory is received for 5 sec in order.

b. During memory scan, the channel number flashes at 1 Hz.

c. When the number of memory reached ch 6, the band is changed as shown below.  
And memory scan is continuous from ch 1.

• In case of FM band



• In case of MW band

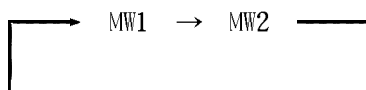

d. If the station is not received by IF check or stop signal on SD input when the preset memory is called, the next preset memory is called immediately.

If the station is received, the next preset memory is called after receiving the station for 5 sec.

e. When the (MEMORY-SCAN) key is pushed in the memory scan, the memory scan is stopped on the preset memory that is receiving now.

## AUTO MEMORY

### 1. PRINCIPAL

Writing the station in the preset memory automatically.

### 2. KEY TO BE USED

[MEMORY-SCAN] key.

### 3. FUNCTIONS

- a. When the [MEMORY-SCAN] key is pushed for more than 2 sec, the search tuning is started from station of receiving now.  
And if the first station is receiving, it is written in the preset memory, the orders of the memory written are arranged from ch 1 to ch 6.  
The search tuning runs for local mode in first cycle. And when the station of 6'th is not received in local mode, the search tuning runs for DX mode in second cycle. The auto memory function is stopped after calling ch 1 of start band. if the station of 6'th is received or if the search tuning runs for DX mode in second cycle. When the station is not received, the start frequency is called and the auto memory function stopped.
- b. In the auto memory scan function, the "CH" mark flashes at 1 Hz.

# KIC9321F-005

## FUNCTION CHANGE

### 1. PRINCIPAL FUNCTION

Changing function.

### 2. KEY AND I/O PORT TO BE USED

[POWER] key, [CD] key, TAPE INPUT, CD INPUT

### 3. FUNCTIONS

a. The function mode is changed by signal of the TAPE input (P1-2) or CD input (P1-3)

b. In case of the POWER KEY diode = 0

| P1-1 | P1-3 | POWER KEY | CD KEY | INH | MODE  |
|------|------|-----------|--------|-----|-------|
| L    | L    | -         | L      | L   | CLOCK |
| L    | L    | -         | L      | H   | RADIO |
| H    | L    | -         | L      | H   | TAPE  |
| L    | H    | -         | H      | H   | CD    |

c. In case of the POWER KEY diode = 1

| P1-1 | P1-3 | POWER KEY | CD KEY | INH | MODE  |
|------|------|-----------|--------|-----|-------|
| L    | L    | L         | L      | L   | CLOCK |
| L    | L    | L         | L      | H   | CLOCK |
| L    | L    | H         | L      | H   | RADIO |
| H    | L    | H         | L      | H   | TAPE  |
| L    | H    | H         | H      | H   | CD    |

d. A-MUTE output outputs "H" for 1,000mS, if tape mode or CD mode is changed from radio mode to or if radio mode is changed from tape mode or CD mode to.

e. The display is divided as shown below.

- Radio relation : band indicator (FM/MW/LW, 1/2/3), frequency display, kHz/MHz mark  
memory channel display, "MONO", "ST", "LOC", "VF", "SK"
- Tape relation : "TAPE", "MTL", "DNR", "APS", "<" ">"
- CD relation : CD, DISC indicator

Note : another indicator is common independently of each function.

## ELECTRONIC VOLUME CONTROL FUNCTION

### 1. PRINCIPAL FUNCTION

Controlling the electronic volume IC

### 2. KEY TO BE USED

[VOL-SEL] key, [VOL-UP] key, [VOL-DOWN] key, [MUTE] key.

### 3. FUNCTIONS

a. The controlling the electronic volume IC is only enable, when E-VOL diode is set.

b. The volume mode is changed by pushing [VOL-SEL] key as below.

(1) In case of FADER diode = 1

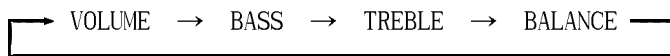

(2) In case of FADER diode = 0



c. The volume can be used range that is shown bellow.

(1) In case of TEA6330T

- VOLUME : +20 ~ -66dB / 2dB step
- BASS : +15 ~ -12dB / 3dB step
- TREBLE : ±12dB / 3dB step
- BALANCE : MAX 15dB
- FADER : 0 ~ -30dB / 2dB step

(2) In case of TDA7313

- VOLUME : 0 ~ -78.75dB / 1.25dB step
- BASS : ±14dB / 1.25dB step
- TREBLE : ±14dB / 1.25dB step
- SPEAKER : LF, RF, LR, RR each 0 ~ -38.75dB

### 1) VOLUME

a. In case of TEA6330T

In the volume mode, the volume up or down is executed at the rate of 2dB / 1push by pushing the [VOL-UP] or [VOL-DOWN] key.

If the [VOL-UP] or [VOL-DOWN] key is pushed for 500mS.

the volume up or down is continued at the rate of 2 dB / 150mS.

b. In case of TDA7313

In the volume mode, the volume up or down is executed at the rate of 1.25dB/1push by pushing the [VOL-UP] or [VOL-DOWN] key.

If the [VOL-UP] or [VOL-DOWN] key is pushed for 500mS.

the volume up or down is continued at the rate of 1.25dB/150mS.

# KIC9321F-005

c. The level of volume can be used range that is shown bellow.

| MODE     | (A)          | (B)         | (C)           | (D)            | (E)            | (F)            | (G)           | (H)          | (I)        | (J)          | (K)       |
|----------|--------------|-------------|---------------|----------------|----------------|----------------|---------------|--------------|------------|--------------|-----------|
| TEA6330T | ~            | ~           | ~             | ~              | ~              | ~              | ~             | ~            | ~          | ~            | ~         |
|          | MUTE<br>[dB] | -50<br>[dB] | -42<br>[dB]   | -34<br>[dB]    | -26<br>[dB]    | -18<br>[dB]    | -12<br>[dB]   | -8<br>[dB]   | -4<br>[dB] | -2<br>[dB]   | 0<br>[dB] |
| TDA7313  | ~            | ~           | ~             | ~              | ~              | ~              | ~             | ~            | ~          | ~            | ~         |
|          | MUTE<br>[dB] | -50<br>[dB] | -42.5<br>[dB] | -33.75<br>[dB] | -26.25<br>[dB] | -18.75<br>[dB] | -12.5<br>[dB] | -7.5<br>[dB] | -5<br>[dB] | -2.5<br>[dB] | 0<br>[dB] |

## 2) BASS / TREBLE

a. In case of TEA6330T.

In the bass or treble mode, the bass or treble boost is executed at the rate of 1dB/1push when [VOL-UP] key is pushed.

In the bass or treble mode, the bass or treble cut is executed at the rate of 1dB/1push when [VOL-DOWN] key is pushed.

If the [VOL-UP] or [VOL-DOWN] key is pushed for 500mS.

the bass boost/cut or treble boost/cut is continued at the rate of 1dB/150mS.

b. In case of TDA7313.

In the bass or treble mode, the bass or treble boost is executed at the rate of 1.25dB/1push when [VOL-UP] key is pushed.

In the bass or treble mode, the bass or treble cut is executed at the rate of 1.25dB/1push when [VOL-DOWN] key is pushed.

If the [VOL-UP] or [VOL-DOWN] key is pushed for 500mS.

the bass boost/cut or treble boost/cut is continued at the rate of 1.25dB/150mS.

c. When the bass boost/cut or treble boost/cut is continued, the active stops in 0dB for 500mS and start again.

d. The level of bass or treble can be used range that is shown bellow.

| MODE     | (A)  | (B)  | (C)  | (D)  | (E)  | (F)  | (G)  | (H)  | (I)  | (J)  | (K)  |
|----------|------|------|------|------|------|------|------|------|------|------|------|
| TEA6330T | ~    | -12  | -9   | -6   | -3   | 0    | 3    | 6    | 9    | 12   | 15   |
|          | [dB] | [dB] | [dB] | [dB] | [dB] | [dB] | [dB] | [dB] | [dB] | [dB] | [dB] |
| TDA7313  | -14  | -10  | -8   | -6   | -4   | -2~  | 4    | 6    | 8    | 10   | 14   |
|          | [dB] | [dB] | [dB] | [dB] | [dB] | [dB] | [dB] | [dB] | [dB] | [dB] | [dB] |

## 3) balance

a. In the balance mode, left channel is attenuated at the rate of 1dB/1push by pushing the [VOL-UP] key.

In the balance mode, right channel is attenuated at the rate of 1dB/1push by pushing the [VOL-DOWN] key. If the [VOL-UP] or [VOL-DOWN] key is pushed for 500mS, the left channel or right channel attenuate

is continued at the rate of 1dB/150mS.

b. When the bass boost/cut or treble boost/cut is continued, the active stops in 0dB for 500mS and start again.

# KIC9321F-005

c. The level of balance can be used that is shown bellow.

| MODE     | (A)       | (B)              | (C)             | (D)             | (E)             | (F)            | (G)             | (H)             | (I)             | (J)              | (K)               |
|----------|-----------|------------------|-----------------|-----------------|-----------------|----------------|-----------------|-----------------|-----------------|------------------|-------------------|
| TEA6330T | MUTE<br>~ | -14<br>~<br>[dB] | -8<br>~<br>[dB] | -3<br>~<br>[dB] | -1<br>~<br>[dB] | 0<br>~<br>[dB] | -1<br>~<br>[dB] | -3<br>~<br>[dB] | -8<br>~<br>[dB] | -14<br>~<br>[dB] | MUTE<br>~<br>[dB] |
| TDA7313  | MUTE<br>~ | -14<br>~<br>[dB] | -8<br>~<br>[dB] | -3<br>~<br>[dB] | -1<br>~<br>[dB] | 0<br>~<br>[dB] | -1<br>~<br>[dB] | -3<br>~<br>[dB] | -8<br>~<br>[dB] | -14<br>~<br>[dB] | MUTE<br>~<br>[dB] |

#### 4) FADER

a. In the fader mode, the front output is executed at the rate of 1 step specified when [VOL-UP] key is pushed.

In the fader mode, the rear output is executed at the rate of 1 step specified when [VOL-DOWN] key is pushed.

If the [VOL-UP] or [VOL-DOWN] key is pushed for 500mS.

the front or rear attenuate is continued at the rate of 1 step/150mS.

b. When the bass boost/cut or treble boost/cut is continued, the active stops in 0dB for 500mS and start again.

c. The level of fader can be used range that is shown bellow.

| MODE     | (A)               | (B)              | (C)              | (D)              | (E)             | (F)               | (G)             | (H)              | (I)              | (J)              | (K)               |
|----------|-------------------|------------------|------------------|------------------|-----------------|-------------------|-----------------|------------------|------------------|------------------|-------------------|
| TEA6330T | MUTE<br>~<br>[dB] | -30<br>~<br>[dB] | -16<br>~<br>[dB] | -10<br>~<br>[dB] | -6<br>~<br>[dB] | -2~<br>+2<br>[dB] | -6<br>~<br>[dB] | -10<br>~<br>[dB] | -16<br>~<br>[dB] | -30<br>~<br>[dB] | MUTE<br>~<br>[dB] |
| TDA7313  | MUTE<br>~<br>[dB] | -35<br>~<br>[dB] | -16<br>~<br>[dB] | -10<br>~<br>[dB] | -6<br>~<br>[dB] | -2~<br>+2<br>[dB] | -6<br>~<br>[dB] | -10<br>~<br>[dB] | -16<br>~<br>[dB] | -35<br>~<br>[dB] | MUTE<br>~<br>[dB] |

# KIC9321F-005

## CLOCK

### 1. PRINCIPAL FUNCTION

The clock of 12H or 24H displayed

### 2. KEY TO BE USED

[T-UP(MIN-ADJ.)] key, [T-DOWN(HOUR-ADJ.)] key, [DISPLAY] key, [MEMORY] key  
CLOCK DISABLE diode, CLOCK DISPLAY diode, O.T.M DISABLE diode, 12H/24H diode.

### 3. FUNCTIONS

- a. The display of clock is disable when CLOCK DISABLE diode is set.
- b. The display of clock is disable in power off when CLOCK DISPLAY diode is set.
- c. The display changes to the clock display by pushing the [DISPLAY] key in the display of radio, tape or CD.  
The display returns back to one that was being indicated before, when the [DISPLAY] key is pushed again.
- d. In setting O.T.M DISABLE diode, the clock adjusting enable state is set for 5 sec  
If the [MEMORY] key is pushed in clock display.  
The clock display flashes at 1Hz in the clock adjusting enable state. When the [MEMORY] key is pushed again the clock adjusting enable state, the second of the clock is set to the zero, and that state are released.  
After finishing the clock adjust state, the [MEMORY] key is pushed again, the clock is set to the adjusting time.
- e. In no setting O.T.M DISABLE diode, the clock adjusting enable state is set for 5 sec.  
If the [DISPLAY] key is pushed for 2 second in clock display.  
The clock display flashes at 1 Hz in the clock adjusting enable state. When the [DISPLAY] key is pushed again in the clock adjusting enable state, the second of the clock is set to the zero, and that state are released. After finishing the clock adjust state, the [DISPLAY] key is pushed again, the clock is set to the adjusting time.
- f. In the clock adjusting enable state, the minute of clock is adjusted by pushing [T-UP(MIN-ADJ)] key, the hour of clock is adjusted by pushing [T-DOWN(HOUR-ADJ)] key.
- g. Setting the second to the zero is shown below.

1. In case of the [T-UP(MIN-ADJ)] or [T-DOWN(HOUR-ADJ)] key

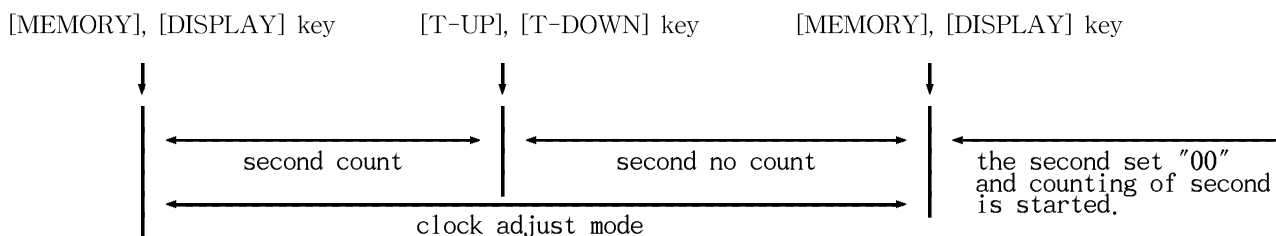



2. In case of the [MEMORY] or [DISPLAY] key

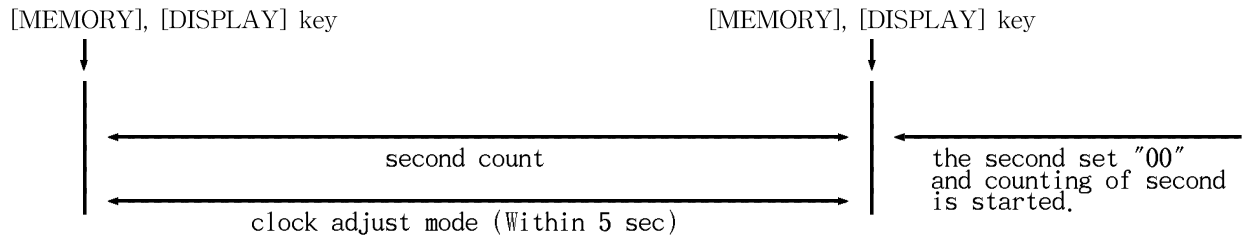

- h. The minute or the hour step up the rate of 1 step / 1 push when the [T-UP(MIN-ADJ)] or [T-DOWN (HOUR-ADJ)] key is pushed for less than 500 mS in the clock adjusting enable state.  
The minute step up rate of the 1 step / 100mS. When the [T-UP(MIN-ADJ)] key is pushed for more than 500mS. The hour step up rate of the 1 step / 200mS. When the [T-DOWN (HOUR-ADJ)] key is pushed for more than 500mS.
- i. In the clock adjusting enable state, the clock display does not flash during pushing the [T-UP(MIN-ADJ)] or [T-DOWN(HOUR-ADJ)] key.
- j. If the [T-UP(MIN-ADJ)] or [T-DOWN(HOUR-ADJ)] key is not pushed for 5 sec in the clock adjusting enable state, that state will be released. In this case, the second is not set the zero.
- k. When 12H/24H diode is set, the clock is 24H display. And when 12H/24H diode is not set, the clock is 12H display with "AM" and "PM" mark.

## BUZZER OUT

### 1. PRINCIPAL FUNCTION

The buzzer sound outputs when the function key is pushed.

### 2. I/O TO BE USED

PEE output

### 3. FUNCTIONS

- a. The buzzer sound outputs for 50mS when the function key is pushed.
- b. The buzzer sound outputs for 200mS  
If the frequency is written in the memory by the preset memory key, or if the auto memory function is started.

# KIC9321F-005

---

## SDK FUNCTION

### 1. PRINCIPAL FUNCTION

Receiving the traffic information station.

### 2. KEY AND I/O TO BE USED

[VF] key, VF diode, VF output, SK input, DK input

### 3. FUNCTIONS

- a. [VF] key is enable when VF diode is set.
- b. The receiving band is changed to the VF band by pushing the [VF] key.
- c. In VF band, the "FM" mark on LCD is indicated and the VF output outputs "H".
- d. In radio mode, it is necessary that the SK input inputs "H" with the stop signal or the counting intermediate frequency by IF counter for stopping of auto tuning, writing memory of auto memory or check of the memory scan.
- e. In tape or CD mode, it is necessary that the SK input inputs "H" with the stop signal or the counting intermediate frequency by IF counter for stopping of auto tuning, writing memory of auto memory or check of the memory scan. At the moment tape or CD mode is DK stand by mode. And tape or CD mode changes radio when the DK input inputs "H".
- f. The local output outputs "H" in the first cycle of VF search, and the local output outputs "L" in the second cycle of VF search.
- g. During the VF search function, the "VF" mark flashes at 1 Hz rate.

In case of IF check (VF band)

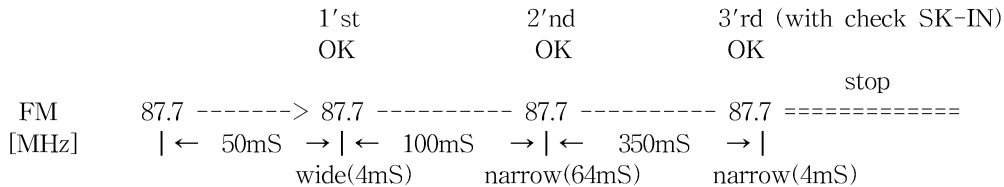

## RADIO MONITOR

### 1. PRINCIPAL FUNCTION

Receiving frequency in TAPE or CD mode.

### 2. KEY AND I/O TO BE USED

[RADIO-MONI] key, [CD] key, TAPE input, CD input

### 3. FUNCTIONS

- a. The radio action is enable when [RADIO-MONI] key is pushed in TAPE or CD mode.
- b. The radio action returns in tape or CD mode when [RADIO-MONI] key is pushed in radio monitor.
- c. During the radio monitor, the "RMON" mark flashes at 1 Hz rate.
- d. When TAPE or CD mode is changed to radio mode, the radio monitor is released.

## POWER OUT

### 1. PRINCIPAL FUNCTION

Controlling the power output

### 2. KEY AND I/O TO BE USED

[POWER] key, POWER KEY diode, power output, ACC input (INH terminal)

### 3. FUNCTIONS

- (1) In case of [POWER] key disable (POWER KEY diode = 0)
  - a. ACC input inputs "H" in power on, and ACC input inputs "L" in power off.
  - b. During power on, power output outputs "H".
- (2) In case of [POWER] key enable (POWER KEY diode = 1)
  - a. The power is supplied by pushing [POWER] key in power off when ACC input inputs "H".  
The power is shut off by pushing [POWER] key in power on when ACC input inputs "H".
  - b. The power is shut off in power on when ACC input is changed to "L" level.  
And the power is not supplied if ACC input is changed to "H" level.
  - c. During power on, power output outputs "H".
  - d. [POWER] key is disable when ACC input inputs "L".

# KIC9321F-005

## TRACKING DATA

### 1. PRINCIPAL FUNCTION

setting initial state when the power supply is turned on.

### 2. KEY TO BE USED

Nothing

### 3. FUNCTIONS

1) In case of FM or MW band, the frequency in the preset memory is set as shown below.

| AREA                           | BAND | M1     | M2     | M3     | M4      | M5      | M6     |
|--------------------------------|------|--------|--------|--------|---------|---------|--------|
| EUROPE                         | FM   | 87.5 M | 90.0 M | 98.0 M | 106.0 M | 108.0 M | 87.5 M |
|                                | MW   | 522 k  | 630 k  | 999 k  | 1404 k  | 1620 k  | 522 k  |
| EAST EUROPE                    | FM   | 65.0 M | 74.0 M | 87.5 M | 98.0 M  | 108.0 M | 65.0 M |
|                                | MW   | 522 k  | 630 k  | 999 k  | 1404 k  | 1620 k  | 522 k  |
| USA 1                          | FM   | 87.5 M | 90.1 M | 98.1 M | 106.1 M | 107.9 M | 87.5 M |
|                                | MW   | 520 k  | 630 k  | 1000 k | 1400 k  | 1720 k  | 520 k  |
| USA 2                          | FM   | 87.5 M | 90.0 M | 98.0 M | 106.0 M | 108.0 M | 87.5 M |
|                                | MW   | 520 k  | 630 k  | 1000 k | 1400 k  | 1720 k  | 520 k  |
| LATIN AMERICA                  | FM   | 87.5 M | 90.0 M | 98.0 M | 106.0 M | 108.0 M | 87.5 M |
|                                | MW   | 530 k  | 630 k  | 1000 k | 1400 k  | 1710 k  | 530 k  |
| AUSTRALIA MIDDLE AND NEAR EAST | FM   | 87.5 M | 90.0 M | 98.0 M | 106.0 M | 108.0 M | 87.5 M |
|                                | MW   | 531 k  | 630 k  | 999 k  | 1404 k  | 1602 k  | 531 k  |
| JAPAN                          | FM   | 76.0 M | 80.0 M | 83.0 M | 86.0 M  | 90.0 M  | 76.0 M |
|                                | MW   | 522 k  | 630 k  | 999 k  | 1404 k  | 1629 k  | 522 k  |
| SOUTH AFRICA                   | FM   | 87.5 M | 90.0 M | 98.0 M | 106.0 M | 108.0 M | 87.5 M |
|                                | MW   | 531 k  | 630 k  | 999 k  | 1404 k  | 1602 k  | 531 k  |

2) In case of LW band.

| CODE |     | MEMORY |       |       |       |       |       |
|------|-----|--------|-------|-------|-------|-------|-------|
| LW1  | LW0 | M1     | M2    | M3    | M4    | M5    | M6    |
| 0    | 1   | 153 k  | 164 k | 218 k | 272 k | 279 k | 153 k |
| 1    | 0   | 144 k  | 164 k | 218 k | 272 k | 288 k | 144 k |
| 1    | 1   | 146 k  | 164 k | 218 k | 272 k | 290 k | 146 k |

b. The receiving band is set FM band.

c. The volume level is set -50dB.

d. Setting 12H/24H diode, the clock of 24 hour is set "0:00"  
when ACC input (  $\overline{\text{INH}}$  terminal ) inputs "L".  
No setting 12H/24H diode, the clock of 12 hour is set "AM 12:00"  
when ACC input (  $\overline{\text{INH}}$  terminal ) inputs "L".

# KIC9321F-005

## MUTE AND TIMING

(unit : msec)

### 1. In case of ACC input of 'H' (Without POWER KEY diode)

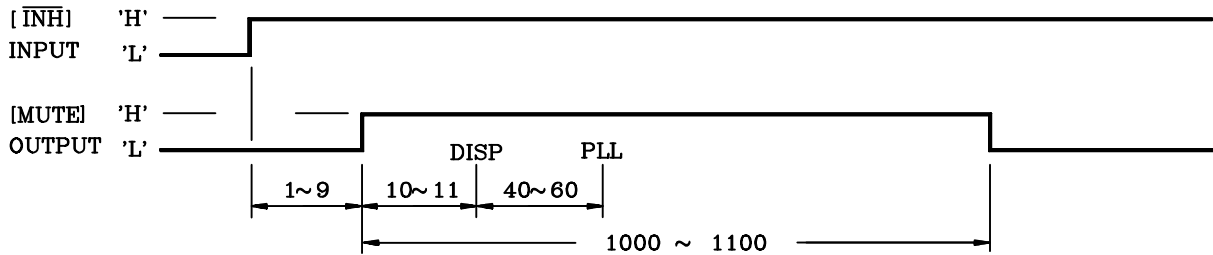

PLL : The timing to set the PLL data  
DISP : The timing to set the display data

### 2. In case of ACC input of 'L' (Without POWER KEY diode)

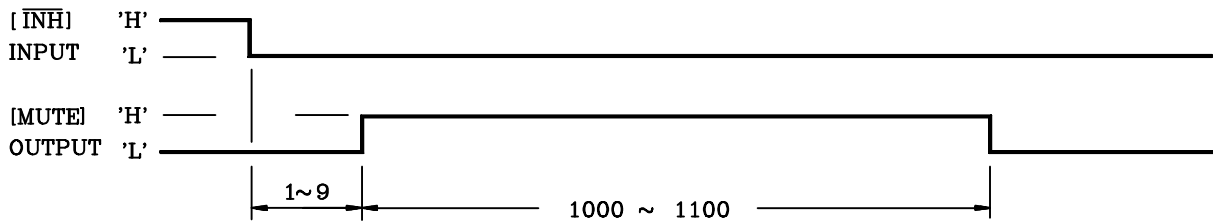

### 3. Setting power supply (With POWER KEY diode)

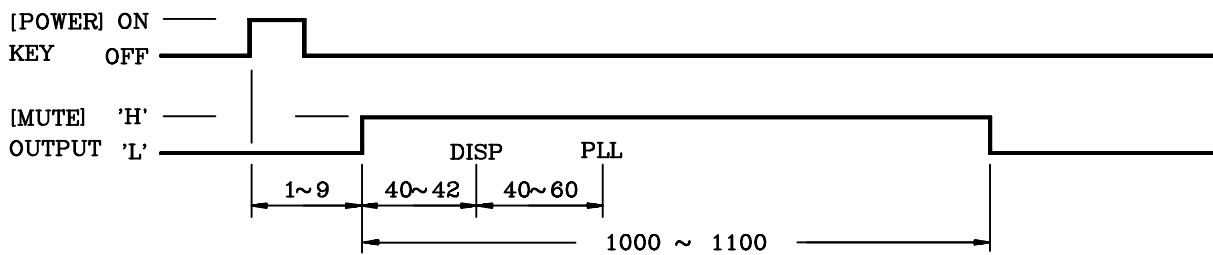

### 4. No setting power supply (With POWER KEY diode)

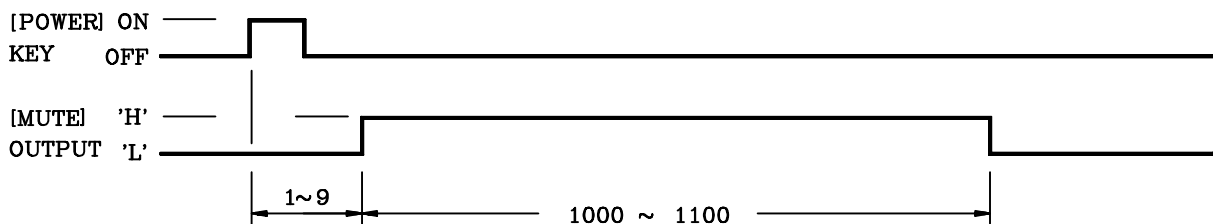

# KIC9321F-005

## MUTE AND TIMING

(unit : msec)

### 5. Calling preset memory (With O.T.M DISABLE diode)

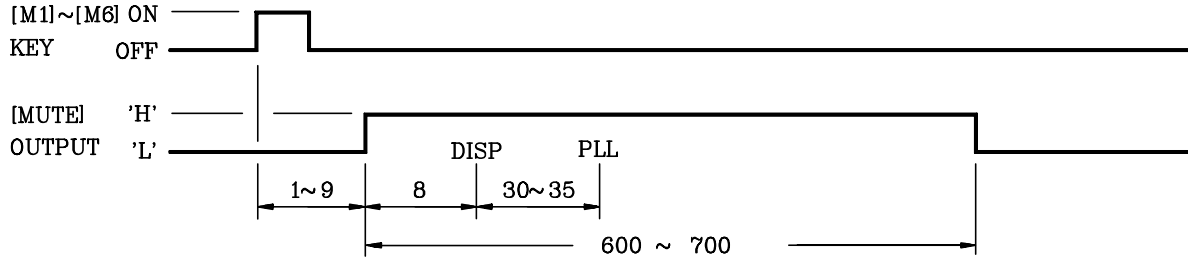

PLL : The timing to set the PLL data  
 DISP : The timing to set the display data

### 6. Band change

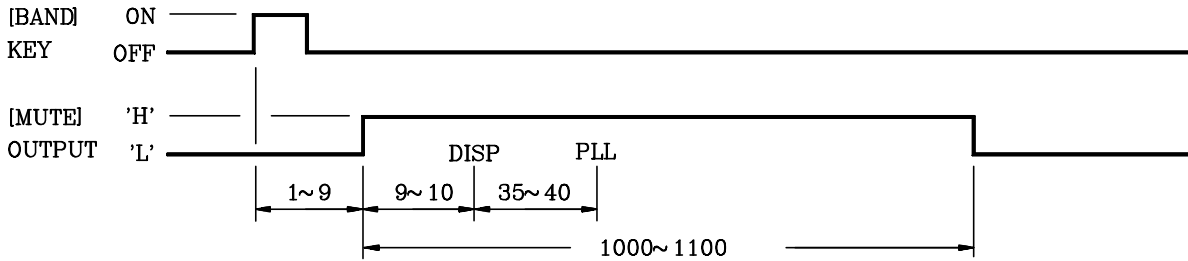

### 7. In case of ELECTRONIC VOLUME IC

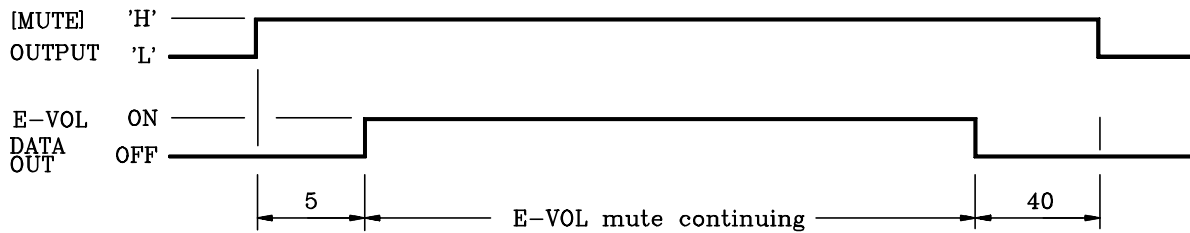

# KIC9321F-005

## MUTE AND TIMING

(unit : msec)

### 8. In case of 1 step / 1 push

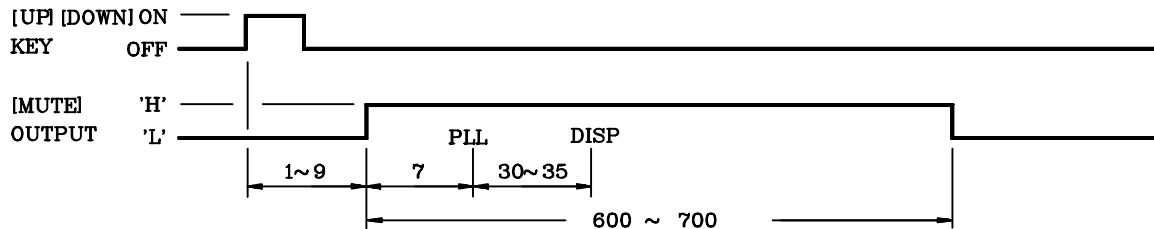

\* T-MUTE output outputs 'H' from 1000mS to 1100mS

PLL : The timing to set the PLL data  
DISP : The timing to set the display data

### 9. In case of seek or scan tuning

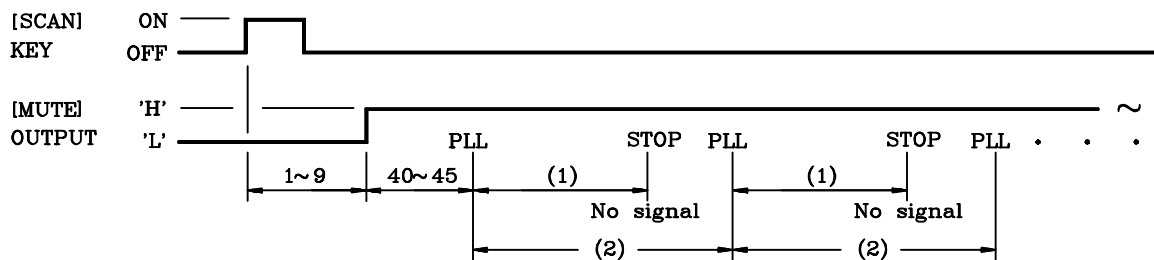

PLL : The timing to set the PLL data  
STOP : The timing to stop the PLL

- (1) : AM=50~60, FM=50~60, LW=50~60
- (2) : AM=50~70, Fm=50~70, LW=50~70 (1can speed)

### 10. In case of stopping seek or scan tuning

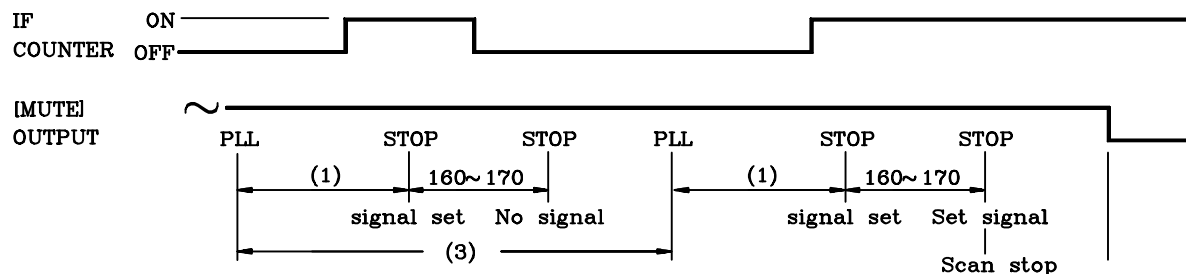

- (1) : AM=50~60, FM=50~60, LW=50~60
- (3) : AM=210~230, FM=210~230, LW=210~230

\* In detecting first stop signal, stop signal is checked again after 100mS.  
And if second stop signal is detected, seek or scan tuning stops.



# KIC9321F-005

## MUTE AND TIMING

(unit : msec)

### 11. In case of running seek tuning (VF band)

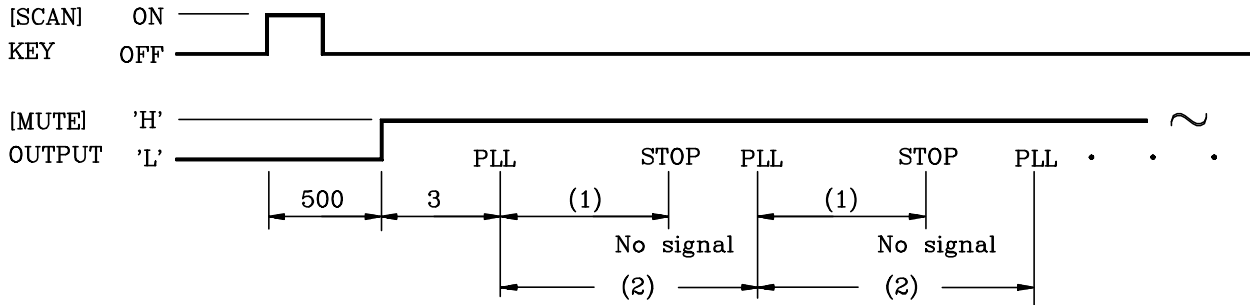

PLL : The timing to set the PLL data

STOP : The timing to stop the PLL

(1) : VF = 50 ~ 60

(2) : VF = 50 ~ 70 (1can speed)

### 12. In case of stopping seek tuning (VF band)

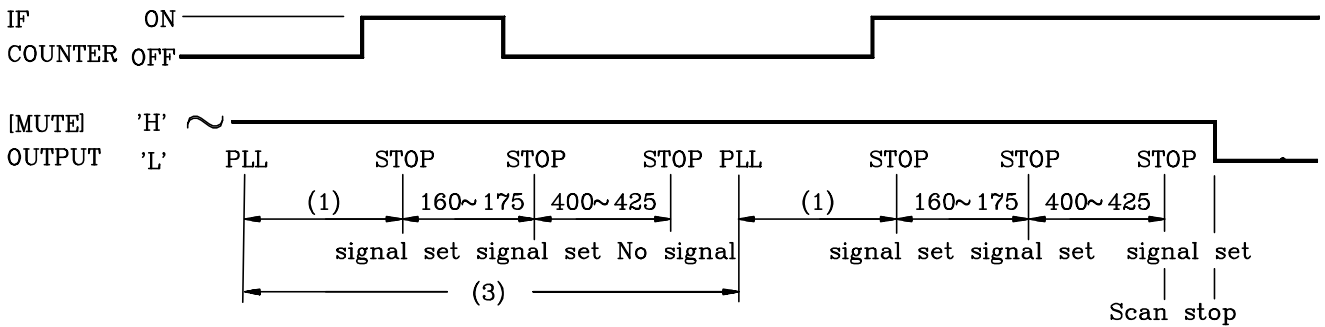

(1) : VF = 50 ~ 60

(3) : VF = 610 ~ 630

\* In detecting first stop signal, stop signal is checked again after 100mS.  
And SK signal is checked again after 350mS. if second stop signal is detected.  
The seek tuning of VF band stops when SK signal is detected.