

316L SS Pressure Sensor

High Performance

0-100 mV Output

Absolute and Gage

Low Pressure

- ▶ Hydraulic Controls
- ▶ Process Control
- ▶ Oceanography
- ▶ Refrigeration/Compressors
- ▶ Pressure Transmitters
- ▶ Level Systems

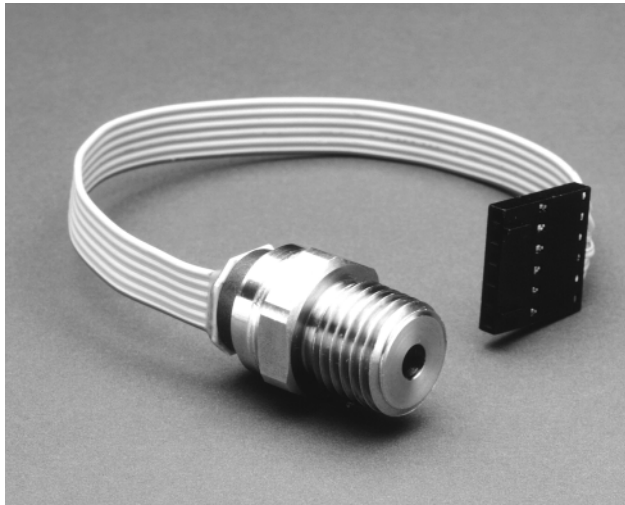

DESCRIPTION

The Model 96 is a small profile, media compatible, piezoresistive silicon pressure sensor packaged in a 316L stainless steel housing. The Model 96 is available with a standard 1/4 NPT fitting. The sensing package utilizes silicone oil to transfer pressure from the 316L stainless steel diaphragm to the sensing element.

The Model 96 is designed for high performance, low pressure applications. A ceramic substrate is attached to the package that contains laser-trimmed resistors for temperature compensation and offset correction. An additional laser-trimmed resistor is included which can be used to adjust an external differential amplifier and provide span interchangeability to within $\pm 1\%$.

Sensors with O-ring fittings, and high pressure sensors are also available. Please contact factory for more information.

FEATURES

- ▶ 1/4 NPT Thread, 5/8" Hex
- ▶ -20°C to $+85^{\circ}\text{C}$ Compensated Temperature Range
- ▶ $\pm 0.1\%$ Pressure Non-linearity
- ▶ $\pm 1.0\%$ Interchangeable Span (provided by gain set resistor)
- ▶ Solid State Reliability
- ▶ Low Power

STANDARD RANGES

Range	psig	psia
0 to 15	●	●
0 to 30	●	●
0 to 50	●	●
0 to 100	●	●
0 to 300	●	●
0 to 500	●	●

DIMENSIONS

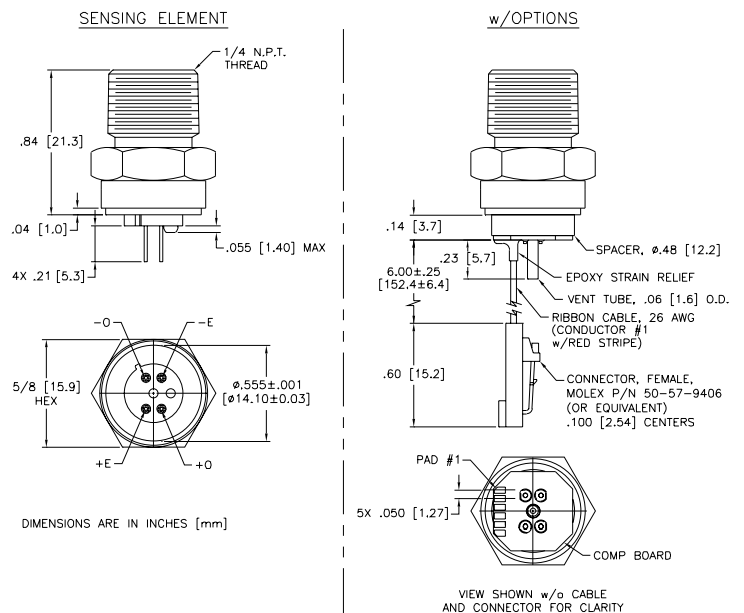

PERFORMANCE SPECIFICATIONS

All parameters specified at 1.5mA and at 25°C, after 10 second warm up, unless otherwise indicated. Unless specifically indicated, only those parameters indicated as tested are verified on each part. Parameters are specified for the compensated version only.

PARAMETERS	MIN	TYP	MAX	UNITS	NOTES
Full Scale Output Span	75	100	125	mV	1
Zero Pressure Output (Offset)	-1	0	1	mV	2
Pressure Non Linearity	-0.10		0.10	±% Span	3
Pressure Hysteresis	-0.05	0.02	+0.05	±% Span	
Repeatability		0.02		±% Span	
Input and Output Resistance	2000	3500	4500	Ω	
Temperature Error - Span (-20°C to +85°C)	-0.75		+0.75	% Span	4
Temperature Error - Offset (-20°C to +85°C)	-0.5		+0.5	% Span	4, 5
Thermal Hysteresis - Span		0.05		% Span	4
Thermal Hysteresis - Offset		0.05		% Span	4
Long Term Stability - Span		0.1		±% Span/year	
Long Term Stability - Offset		0.1		±% Span/year	
Supply Current	0.5	1.5	2.0	mA	6
Output Load Resistance	5			MΩ	7
Insulation Resistance (50 VDC)	50			MΩ	8
Pressure Overload			3X	Rated	
Compensated Temperature Range	-20°C to +85°C				9
Operating Temperature Range	-40°C to +125°C				9
Storage Temperature Range	-50°C to +125°C				9
Media - Pressure Port	Liquids and Gases compatible with 316L Stainless Steel				
Media - Reference Port	Compatible with Silicon, Pyrex, Gold, Fluorosilicone Rubber and 316L Stainless Steel				
Weight	27 g				10

Notes

- For amplified output circuits see application note TN-003.
- Measured at vacuum for absolute (A), ambient for gage (G).
- Best fit straight line.
- Over the temperature range -20°C to +85°C with respect to +25°C.
- 15 psi range sensors have an offset temperature error of ±0.75% (Max) from -20°C to +85°C.
- Guarantees output/input ratiometricity.
- Load resistance to reduce measurement errors due to output loading.
- Between case and sensing element.
- Maximum temperature range for product with standard cable and connector is -20°C to +105°C.
- Weight depends upon configuration (cable, connector, pressure fitting).

ORDERING INFORMATION

96 - 050 G - 4 C T

- T = Vent Tube, Blank is standard = No tube
- Electrical (C = Ribbon Cable with Connector, P = Solder Pads, R = Ribbon Cable, L = Lead, Uncompensated)
- Pressure Port (4 = 1/4 NPT)
- Type (A = Absolute, G = Gage)
- Pressure Range (15 to 500 psi, 050 = 50 psi)
- Model

For other pressure ranges, process fittings and electrical connections contact factory.

CONNECTIONS

PAD / CONDUCTOR NO	FUNCTION
1	+OUT
2	-EX
3	+EX
4	-OUT
5	GAIN
6	GAIN

APPLICATION SCHEMATIC

