

Negative Output Plastic Detector, 840 - 2200 MHz

DT65-0006

Features

- High Output Sensitivity
- Small, SMT, Plastic SO-14 Package
- Single Design to Cover Cellular, PCS and UMTS Bands
- Single Ended or Differential Output

Description

M/A-COM's DT65-0006 is a plastic detector in an SMT plastic package. The DT65-0006 usable input power range is from Tss to +20 dBm. Square law response is from Tss to approximately -15 dBm, linear range is between -15 dBm and approximately +6 dBm with saturation through +20 dBm and burnout occurring beyond +23 dBm.

This bias schottky detector offers generally high sensitivity (K). The RF power handling of these detectors make them particularly useful in signal processing and power monitoring for telecommunication equipment. An internal reference diode is provided for use as a differential detector.

SO-14

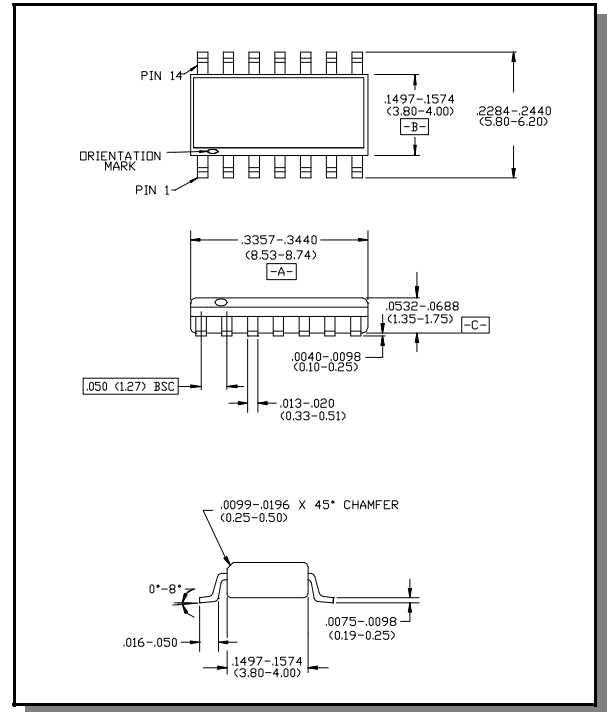

Electrical Specifications: $T_A = 25^\circ\text{C}$, $V_{CC} = +5.0\text{V}$, Load Resistance = 30K Ohms

Parameter	Test Conditions	Frequency	Units	Min.	Typ.	Max.
Voltage Sensitivity (K)	RF IN = -20 dBm	840-2200 MHz	mV/mW	1800	2080	—
In-Band Flatness	RF IN = 0 dBm	840-2200 MHz	dB	—	—	0.50
Tss	RF IN = 0 dBm	1.5 GHz	dBm	—	-47	-45
RF Bypass Capacitance		840-2200 MHz	pF	—	10	—
Video Resistance		840-2200 MHz	Ohms	—	300	—

Recommended PCB Layout

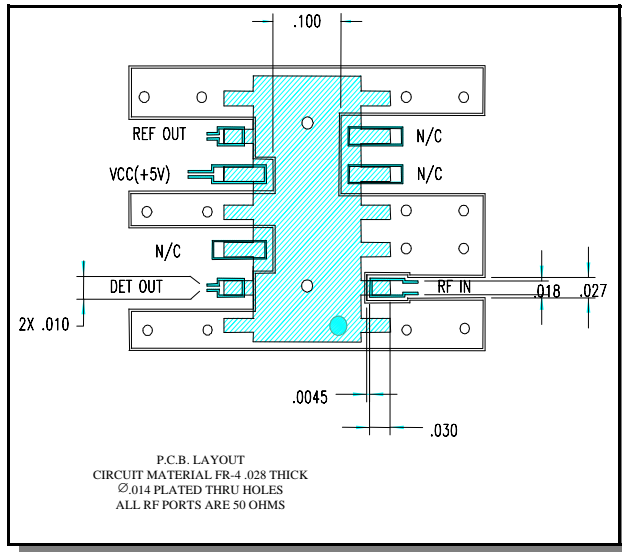

Functional Diagram

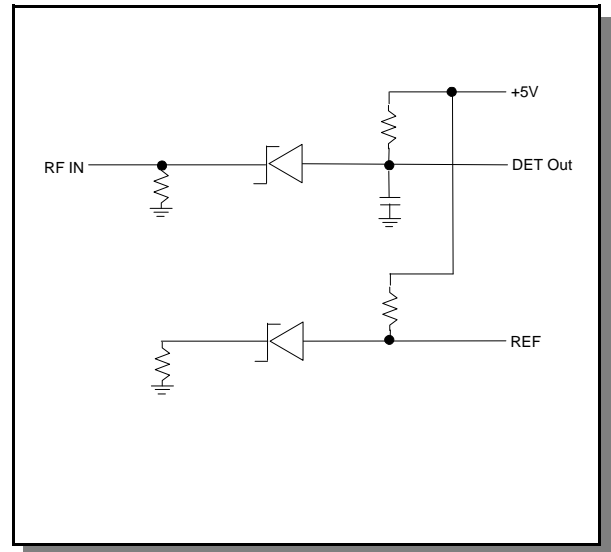

Voltage Sensitivity (K) Typ. (mV/mW)¹

Input Power	-40°C	+25°C	+85°C
-20 dBm	2415	2080	1805
-15 dBm	1900	1670	1510
-10 dBm	1310	1190	1140
-5 dBm	815	790	760
0 dBm	500	490	475
+5 dBm	300	290	280
+10 dBm	170	175	165

1. V_{CC} = +5V, Load Resistance = 30K Ohms.

Pin Configuration

Pin #	Function	Pin #	Function
1	GND	8	GND
2	RF IN	9	REF Out
3	GND	10	V _{CC}
4	GND	11	GND
5	N/C	12	N/C
6	N/C	13	DET Out
7	GND	14	GND

Absolute Maximum Ratings ²

Parameter	Absolute Maximum
Max Input Power	+23 dBm
Applied Voltage (V _{CC})	+10V
Operating Temperature	-40°C to +85°C
Storage Temperature	-65°C to +125°C

2. Operation of this device above any one of these parameters may cause permanent damage.

Ordering Information

Part Number	Package
DT65-0006	Bulk Packaging
DT65-0006TR	Tape and Reel (1K Reel)
DT65-0006-TB	Units Mounted on Test Board

Specifications subject to change without notice.

- North America: Tel. (800) 366-2266
- Asia/Pacific: Tel.+81-44-844-8296, Fax +81-44-844-8298
- Europe: Tel. +44 (1344) 869 595, Fax+44 (1344) 300 020

Visit www.macom.com for additional data sheets and product information.

