

# MOS INTEGRATED CIRCUIT

## $\mu$ PD78052,78053,78054,78055,78056,78058

### 8-BIT SINGLE-CHIP MICROCONTROLLER

#### DESCRIPTION

The  $\mu$ PD78052,78053,78054,78055,78056 and 78058 are the  $\mu$ PD78054 subseries products of the 78K/0 series.

8-bit resolution A/D converter, 8-bit resolution D/A converter, timer, serial interface, real-time output port and interrupt functions.

The  $\mu$ PD78P054 and 78P058, one-time PROM or EPROM products which can be operated in the same supply voltage as for the mask ROM product, and various development tools are also available.

Details of the function description, etc, are described in the following User's Manual. Be sure to read it when designing.

$\mu$ PD78054, 78054Y Subseries User's Manual: U11747E

78K/0 Series User's Manual Instruction: U12326E

#### FEATURES

- Large on-chip ROM & RAM

Items Product Name	Program Memory (ROM)	Data Memory			Package
		Internal High-Speed RAM	Internal Buffer RAM	Internal Expanded RAM	
$\mu$ PD78052	16 Kbytes	512 bytes	32 bytes	No	<ul style="list-style-type: none"> <li>• 80-pin plastic QFP (14 × 14 mm)</li> <li>• 80-pin plastic TQFP (fine pitch) (12 × 12 mm)</li> </ul>
$\mu$ PD78053	24 Kbytes	1024 bytes			
$\mu$ PD78054	32 Kbytes				
$\mu$ PD78055	40 Kbytes				
$\mu$ PD78056	48 Kbytes				
$\mu$ PD78058	60 Kbytes			1024 bytes	

- External memory expansion space: 64K bytes
- Minimum instruction execution time can be varied from high-speed (0.4  $\mu$ s) to ultra-low-speed (122  $\mu$ s)
- I/O ports: 69 (N-ch open-drain : 4)
- 8-bit resolution A/D converter : 8 channels
- 8-bit resolution D/A converter : 2 channels
- Serial interface : 3 channels
- Timer: 5 channels
- Supply voltage:  $V_{DD} = 2.0$  to 6.0 V

#### APPLICATIONS

Cellular phone, pager, printer, AV equipment, airconditioners, cameras, PPC, fuzzy home appliances, vending machine, etc.

The information in this document is subject to change without notice.

## ★ ORDERING INFORMATION

Part Number	Package
$\mu$ PD78052GC-xxx-8BT	80-pin plastic QFP (14 × 14 mm)
$\mu$ PD78052GK-xxx-BE9	80-pin plastic TQFP (fine pitch) (12 × 12 mm)
$\mu$ PD78053GC-xxx-8BT	80-pin plastic QFP (14 × 14 mm)
$\mu$ PD78053GK-xxx-BE9	80-pin plastic TQFP (fine pitch) (12 × 12 mm)
$\mu$ PD78054GC-xxx-8BT	80-pin plastic QFP (14 × 14 mm)
$\mu$ PD78054GK-xxx-BE9	80-pin plastic TQFP (fine pitch) (12 × 12 mm)
$\mu$ PD78055GC-xxx-8BT	80-pin plastic QFP (14 × 14 mm)
$\mu$ PD78055GK-xxx-BE9	80-pin plastic TQFP (fine pitch) (12 × 12 mm)
$\mu$ PD78056GC-xxx-8BT	80-pin plastic QFP (14 × 14 mm)
$\mu$ PD78056GK-xxx-BE9	80-pin plastic TQFP (fine pitch) (12 × 12 mm)
$\mu$ PD78058GC-xxx-8BT	80-pin plastic QFP (14 × 14 mm)
$\mu$ PD78058GK-xxx-BE9	80-pin plastic TQFP (fine pitch) (12 × 12 mm)

**Remark** xxx indicates a ROM code suffix.

★ 78K/0 SERIES PRODUCT DEVELOPMENT

The following shows the 78K/0 Series products development. Subseries name are shown inside frames.

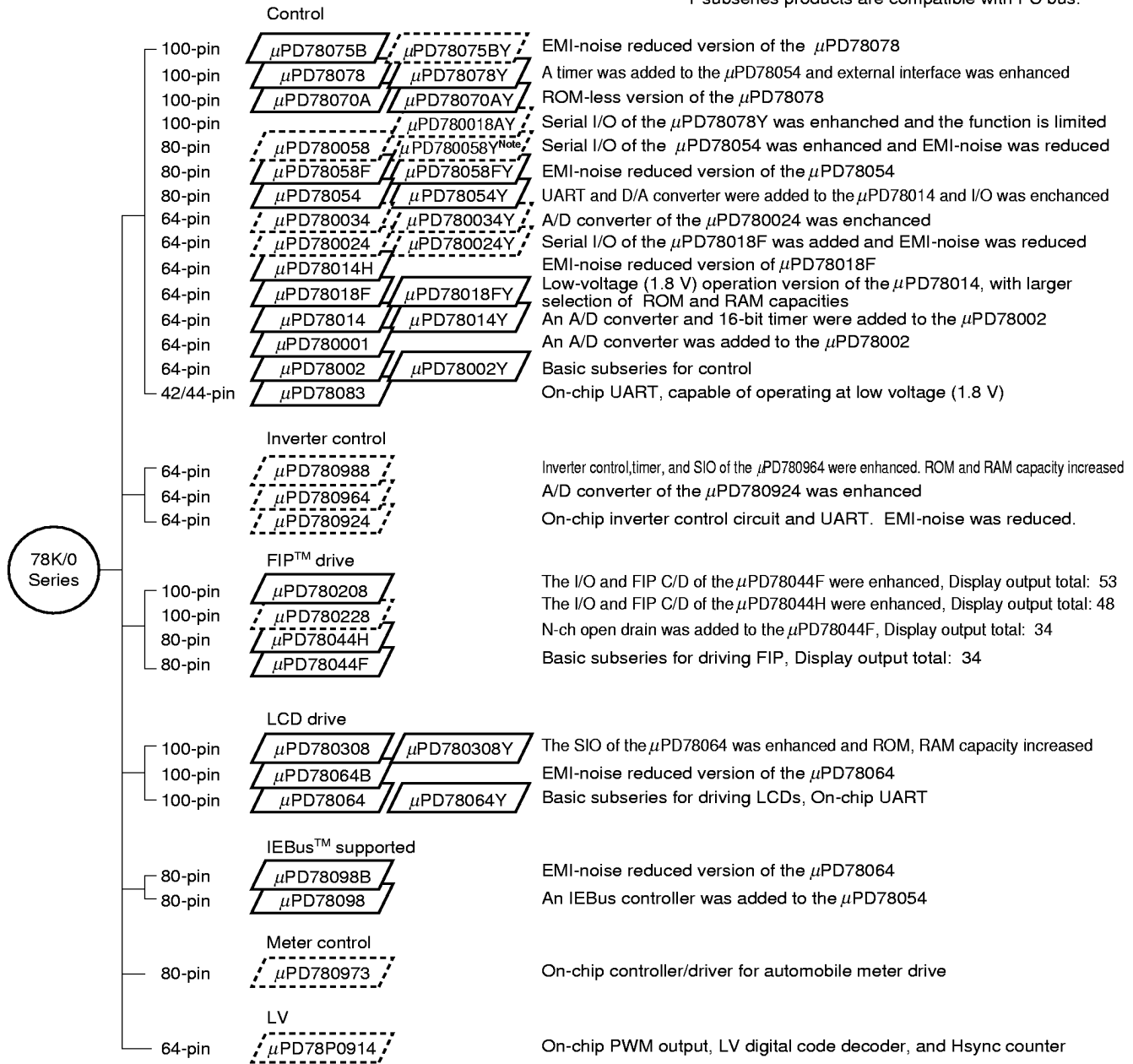
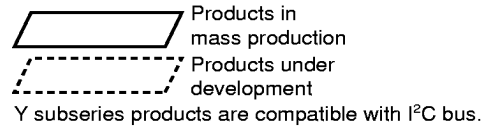

Note Under planning.

The following lists the main functional differences between subseries products.

Function Subseries Name		ROM Capacity	Timer				8-bit A/D	10-bit A/D	8-bit D/A	Serial Interface	I/O	V <sub>DD</sub> MIN. Value	External Expansion		
			8-bit	16-bit	Watch	WDT									
Control	μPD78075B	32 K to 40 K	4 ch	1 ch	1 ch	1 ch	8 ch	-	2 ch	3 ch (UART : 1 ch)	88	1.8 V	○		
	μPD78078	48 K to 60 K									61	2.7 V			
	μPD78070A	-													
	μPD780058	24 K to 60 K	2 ch							3 ch (time division UART: 1 ch)	68	1.8 V			
	μPD78058F	48 K to 60 K								3 ch (UART: 1 ch)	69	2.7 V			
	μPD78054	16 K to 60 K									2.0 V				
	μPD780034	8 K to 32 K						-	8 ch	-	3 ch (UART: 1 ch, time division 3-wire: 1 ch)	51		1.8 V	
	μPD780024							8 ch	-						
	μPD78014H										2 ch	53			
	μPD78018F	8 K to 60 K													
	μPD78014	8 K to 32 K										2.7 V			
	μPD780001	8 K			-	-					1 ch	39			-
	μPD780002	8 K to 16 K				1 ch						53			○
μPD780083					-					8 ch					
Inverter control	μPD780988	32 K to 60 K	3 ch	Note 1	-	1 ch	-	8 ch	-	3 ch (UART: 2 ch)	47	4.0 V	○		
	μPD780964	8 K to 32 K									Note 2	2 ch (UART: 2 ch)		2.7 V	
	μPD780924													8 ch	-
FIP drive	μPD780208	32 K to 60 K	2 ch	1 ch	1 ch	1 ch	8 ch	-	-	2 ch	74	2.7 V	-		
	μPD780228	48 K to 60 K	3 ch	-	-					1 ch	72	4.5 V			
	μPD78044H	32 K to 48 K	2 ch	1 ch	1 ch						68	2.7 V			
	μPD78044F	16 K to 40 K								2 ch					
LCD drive	μPD780308	48 K to 60 K	2 ch	1 ch	1 ch	1 ch	8 ch	-	-	3 ch (time division UART: 1ch)	57	2.0 V	-		
	μPD78064B	32 K								2 ch (UART : 1 ch)					
	μPD78064	16 K to 32 K													
IEBus supported	μPD78098B	40 K to 60 K	2 ch	1 ch	1 ch	1 ch	8 ch	-	2 ch	3 ch (UART : 1 ch)	69	2.7 V	○		
	μPD78098	32 K to 60 K													
Meter control	μPD780973	24 K to 32 K	3 ch	1 ch	1 ch	1 ch	5 ch	-	-	2 ch (UART : 1 ch)	56	4.5 V	-		
LV	μPD78P0914	32 K	6 ch	-	-	1 ch	8 ch	-	-	2 ch	54	4.5 V	○		

- Notes**
- 16-bit timer: 2 channels  
10-bit timer: 1 channel
  - 10-bit timer: 1 channel

OVERVIEW OF FUNCTION

Product Name		μPD78052	μPD78053	μPD78054	μPD78055	μPD78056	μPD78058	
Internal Memory	ROM	16 Kbytes	24 Kbytes	32 Kbytes	40 Kbytes	48 Kbytes	60 Kbytes	
	High-speed RAM	512 bytes	1024 bytes					
	Buffer RAM	32 bytes						
	Expanded RAM	None					1024 bytes	
Memory space		64 Kbytes						
General registers		8 bits × 32 registers (8 bits × 8 registers × 4 banks)						
Minimum instruction execution time		On-chip minimum instruction execution time cycle modification function						
	When main system clock selected	0.4 μs/0.8 μs/1.6 μs/3.2 μs/6.4 μs/12.8 μs (at 5.0-MHz operation)						
	When subsystem clock selected	122 μs (at 32.768-kHz operation)						
Instruction set		<ul style="list-style-type: none"> <li>• 16-bit operation</li> <li>• Multiplication/division (8 bits × 8 bits, 16 bits ÷ 8 bits)</li> <li>• Bit manipulation (set, reset, test, boolean operation)</li> <li>• BCD correction, etc.</li> </ul>						
I/O ports		Total : 69 • CMOS input : 2 • CMOS I/O : 63 • N-ch open-drain I/O : 4						
A/D converter		• 8-bit resolution × 8 channels						
D/A converter		• 8-bit resolution × 2 channels						
Serial interface		<ul style="list-style-type: none"> <li>• 3-wire serial I/O/SBI/2-wire serial I/O mode selectable: 1 channel</li> <li>• 3-wire serial I/O mode (on-chip max. 32-byte automatic data transmit/receive function): 1 channel</li> <li>• 3-wire serial I/O/UART mode selectable : 1 channel</li> </ul>						
Timer		<ul style="list-style-type: none"> <li>• 16-bit timer/event counter : 1 channel</li> <li>• 8-bit timer/event counter : 2 channels</li> <li>• Watch timer : 1 channel</li> <li>• Watchdog timer : 1 channel</li> </ul>						
Timer output		3 (14-bit PWM output × 1)						
Clock output		19.5 kHz, 39.1 kHz, 78.1 kHz, 156 kHz, 313 kHz, 625 kHz, 1.25 MHz, 2.5 MHz, 5.0 MHz (at main system clock 5.0-MHz operation) 32.768 kHz (at subsystem clock 32.768-kHz operation)						
Buzzer output		1.2 kHz, 2.4 kHz, 4.9 kHz, 9.8 kHz (at main system clock 5.0-MHz operation)						
Vectored interrupt sources	Maskable	Internal interrupt : 13, external interrupt : 7						
	Non-maskable	Internal interrupt : 1						
	Software	1						
Test input		Internal : 1, external : 1						
Supply voltage		V <sub>DD</sub> = 2.0 to 6.0 V						
Operating ambient temperature		T <sub>A</sub> = -40 to +85°C						
Package		<ul style="list-style-type: none"> <li>• 80-pin plastic QFP (14 × 14 mm)</li> <li>• 80-pin plastic TQFP (fine pitch) (12 × 12 mm)</li> </ul>						

## CONTENTS

1. PIN CONFIGURATION (Top View) .....	7
2. BLOCK DIAGRAM .....	9
3. PIN FUNCTIONS .....	10
3.1 Port Pins .....	10
3.2 Other Pins .....	12
3.3 Pin I/O Circuits and Recommended Connection of Unused Pins .....	14
4. MEMORY SPACE .....	18
5. PERIPHERAL HARDWARE FUNCTION FEATURES .....	20
5.1 Ports .....	20
5.2 Clock Generator .....	21
5.3 Timer/Event Counter .....	21
5.4 Clock Output Control Circuit .....	24
5.5 Buzzer Output Control Circuit .....	24
5.6 A/D Converter .....	25
5.7 D/A Converter .....	26
5.8 Serial Interfaces .....	26
5.9 Real-Time Output Port Functions .....	28
6. INTERRUPT FUNCTIONS AND TEST FUNCTIONS .....	29
6.1 Interrupt Functions .....	29
6.2 Test Functions .....	33
7. EXTERNAL DEVICE EXPANSION FUNCTIONS .....	34
8. STANDBY FUNCTION .....	34
9. RESET FUNCTION .....	34
10. INSTRUCTION SET .....	35
11. ELECTRICAL SPECIFICATIONS .....	38
12. CHARACTERISTIC CURVES (REFERENCE VALUE) .....	65
13. PACKAGE DRAWINGS .....	67
14. RECOMMENDED SOLDERING CONDITIONS .....	69
APPENDIX A. DEVELOPMENT TOOLS .....	71
APPENDIX B. RELATED DOCUMENTS .....	73

1. PIN CONFIGURATION (Top View)

- 80-pin plastic QFP (14 × 14 mm)  
 μPD78052GC-xxx-8BT, 78053GC-xxx-8BT, 78054GC-xxx-8BT, 78055GC-xxx-8BT,  
 μPD78056GC-xxx-8BT, 78058GC-xxx-8BT
- 80-pin plastic TQFP (fine pitch) (12 × 12 mm)  
 μPD78052GK-xxx-BE9, 78053GK-xxx-BE9, 78054GK-xxx-BE9, 78055GK-xxx-BE9,  
 μPD78056GK-xxx-BE9, 78058GK-xxx-BE9

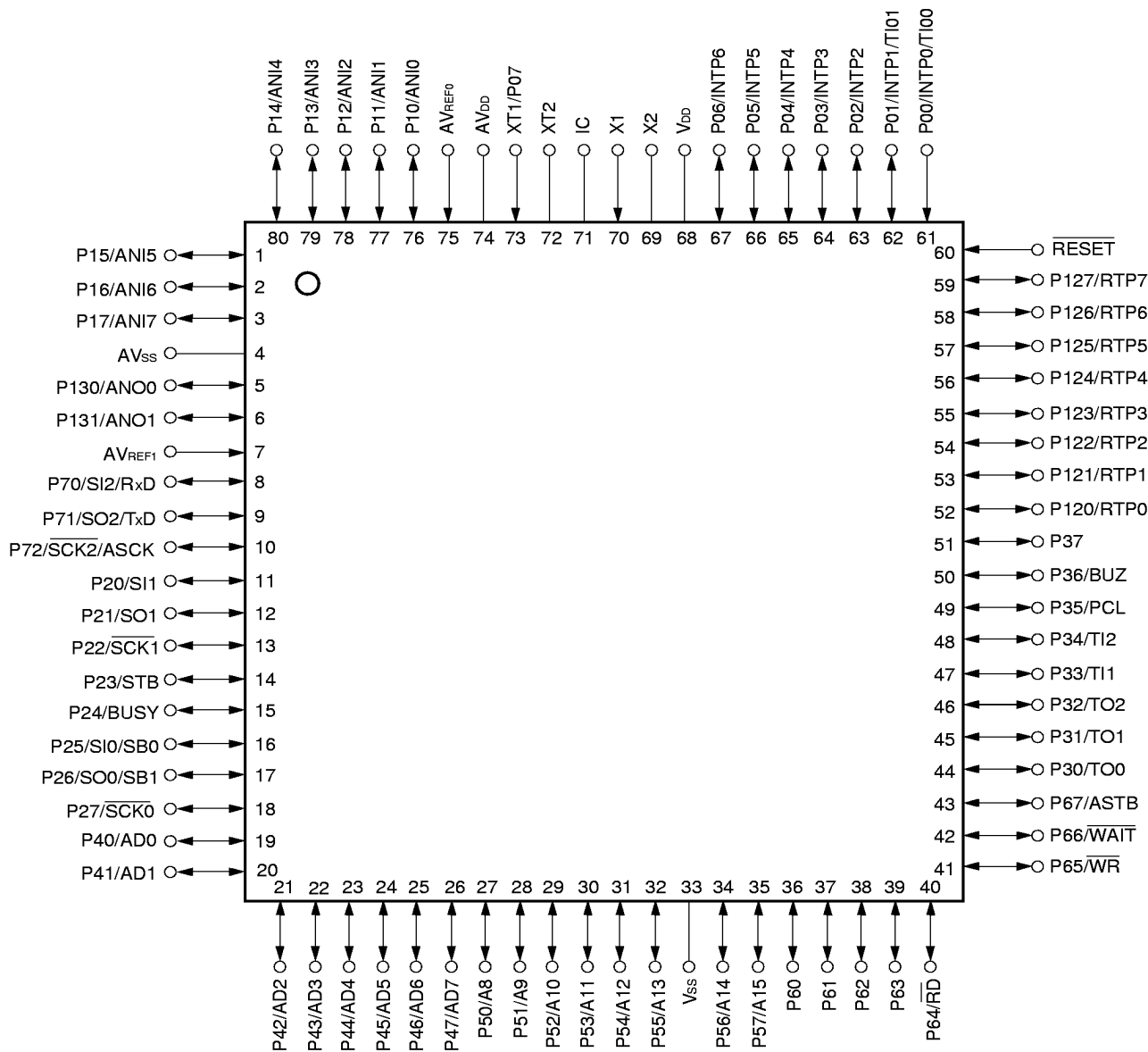

- Cautions**
1. IC (Internally Connected) pin should be connected directly to V<sub>SS</sub>.
  2. AV<sub>DD</sub> pin should be connected to V<sub>DD</sub> pin.
  3. AV<sub>SS</sub> pin should be connected to V<sub>SS</sub> pin.

A8 to A15	: Address Bus	P130, P131	: Port13
AD0 to AD7	: Address/Data Bus	PCL	: Programmable Clock
ANI0 to ANI7	: Analog Input	$\overline{\text{RD}}$	: Read Strobe
ANO0, ANO1	: Analog Output	RESET	: Reset
ASCK	: Asynchronous Serial Clock	RTP0 to RTP7	: Real-Time Output Port
ASTB	: Address Strobe	$\overline{\text{RxD}}$	: Receive Data
AV <sub>DD</sub>	: Analog Power Supply	SB0, SB1	: Serial Bus
AV <sub>REF0</sub> , AV <sub>REF1</sub>	: Analog Reference Voltage	$\overline{\text{SCK0}}$ to $\overline{\text{SCK2}}$	: Serial Clock
AV <sub>SS</sub>	: Analog Ground	SI0 to SI2	: Serial Input
BUSY	: Busy	SO0 to SO2	: Serial Output
BUZ	: Buzzer Clock	STB	: Strobe
IC	: Internally Connected	TI00, TI01	: Timer Input
INTP0 to INTP6	: Interrupt from Peripherals	TI1, TI2	: Timer Input
P00 to P07	: Port0	TO0 to TO2	: Timer Output
P10 to P17	: Port1	TxD	: Transmit Data
P20 to P27	: Port2	V <sub>DD</sub>	: Power Supply
P30 to P37	: Port3	V <sub>SS</sub>	: Ground
P40 to P47	: Port4	$\overline{\text{WAIT}}$	: Wait
P50 to P57	: Port5	$\overline{\text{WR}}$	: Write Strobe
P60 to P67	: Port6	X1, X2	: Crystal (Main System Clock)
P70 to P72	: Port7	XT1, XT2	: Crystal (Subsystem Clock)
P120 to P127	: Port12		



2. BLOCK DIAGRAM

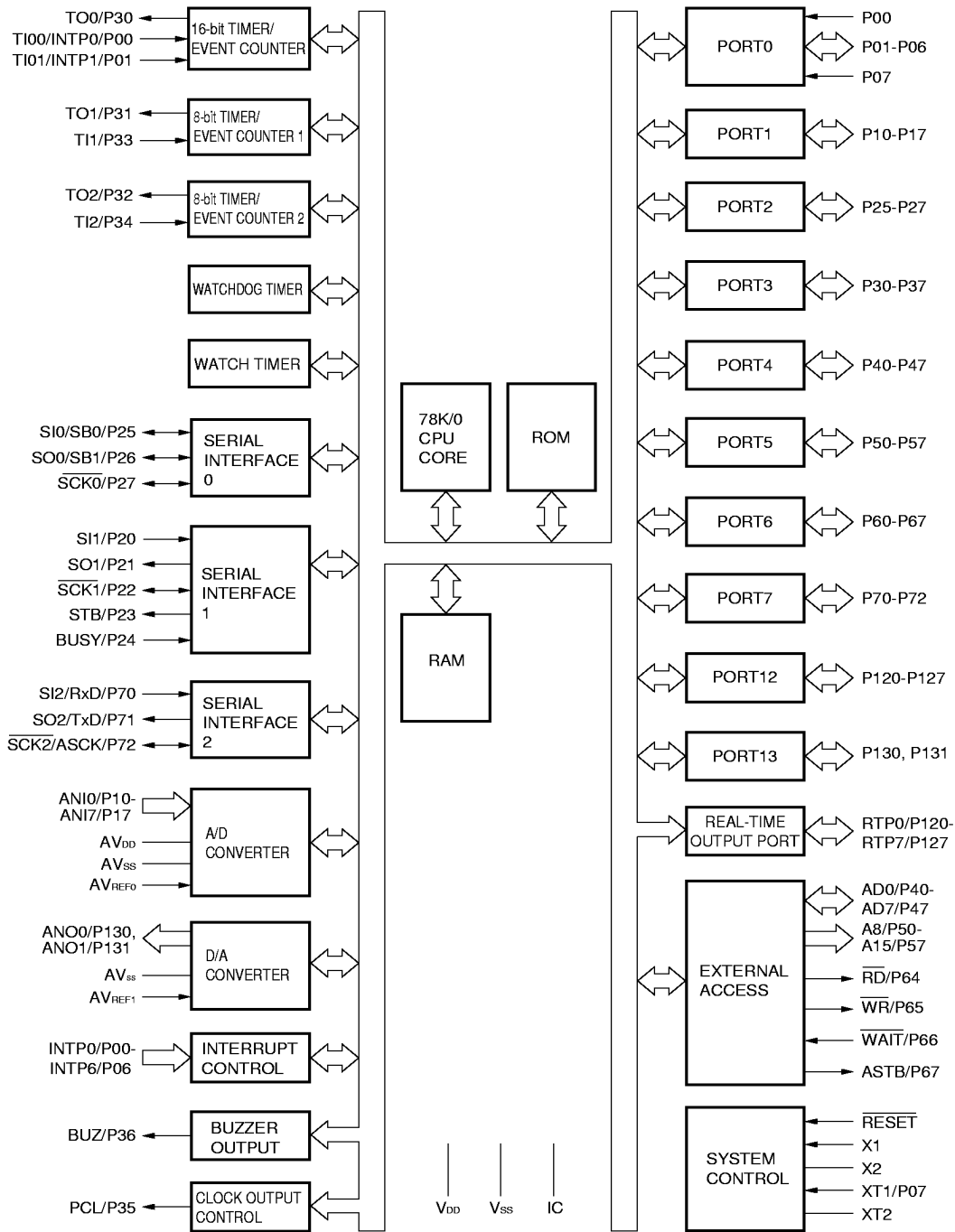

**Remark** The internal ROM and RAM capacities differ depending on the product.

### 3. PIN FUNCTIONS

#### 3.1 Port Pins (1/2)

Pin Name	I/O	Function		After Reset	Dual-Function Pin
P00	Input	Port 0 8-bit I/O port	Input only	Input	INTP0/TI00
P01	Input/ output		Input/output can be specified bit-wise. When used as an input port, pull-up resistor can be used by software.	Input	INTP1/TI01
P02					INTP2
P03					INTP3
P04					INTP4
P05					INTP5
P06	INTP6				
P07 <sup>Note 1</sup>	Input		Input only	Input	XT1
P10 to P17	Input/ output	Port 1 8-bit input/output port. Input/output can be specified bit-wise. When used as an input port, pull-up resistor can be used by software. <sup>Note 2</sup>		Input	ANI0 to ANI7
P20	Input/ output	Port 2 8-bit input/output port. Input/output can be specified bit-wise. When used as an input port, pull-up resistor can be used by software.	Input	SI1	
P21				SO1	
P22				SCK1	
P23				STB	
P24				BUSY	
P25				SI0/SB0	
P26				SO0/SB1	
P27				SCK0	
P30	Input/ output	Port 3 8-bit input/output port. Input/output can be specified bit-wise. When used as an input port, pull-up resistor can be used by software.	Input	TO0	
P31				TO1	
P32				TO2	
P33				TI1	
P34				TI2	
P35				PCL	
P36				BUZ	
P37				—	
P40 to P47	Input/ output	Port 4 8-bit input/output port. Input/output can be specified in 8-bit unit. When used as an input port, pull-up resistor can be used by software. Test input flag (KRIF) is set to 1 by falling edge detection.		Input	AD0 to AD7

- Notes**
1. When using the P07/XT1 pins as an input port, set 1 in the bit 6 (FRC) of the processor clock control register (PCC). On-chip feedback resistor of the subsystem clock oscillator should not be used.
  2. When using the P10/ANI0 to P17/ANI7 pins as the A/D converter analog input pins, set port 1 to the input mode. Use of the pull-up resistor is cancelled automatically.

3.1 Port Pins (2/2)

Pin Name	I/O	Function		After Reset	Dual-Function Pin
P50 to P57	Input/output	Port 5 8-bit input/output port. LED can be driven directly. Input/output can be specified bit-wise. When used as an input port, pull-up resistor can be used by software.		Input	A8 to A15
P60	Input/output	Port 6 8-bit input/output port. Input/output can be specified bit-wise.	N-ch open-drain input/output port. On-chip pull-up resistor can be specified by mask option. LED can be driven directly.	Input	—
P61					
P62					
P63					
P64			When used as an input port, pull-up resistor can be used by software.	Input	$\overline{RD}$
P65					$\overline{WR}$
P66					$\overline{WAIT}$
P67					ASTB
P70	Input/output	Port 7 3-bit input/output port. Input/output can be specified bit-wise. When used as an input port, pull-up resistor can be used by software.	Input	Input	SI2/RxD
P71					SO2/TxD
P72					$\overline{SCK2/ASCK}$
P120 to P127	Input/output	Port 12 8-bit input/output port. Input/output can be specified bit-wise. When used as an input port, pull-up resistor can be used by software.		Input	RTP0 to RTP7
P130, P131	Input/output	Port 13 2-bit input/output port. Input/output can be specified bit-wise. When used as an input port, pull-up resistor can be used by software.		Input	ANO0, ANO1

3.2 Other Pins (1/2)

Pin Name	I/O	Function	After Reset	Dual-Function Pin
INTP0	Input	External interrupt request input for which the effective edge (rising edge, falling edge, or both rising edge and falling edge) can be specified.	Input	P00/TI00
INTP1				P01/TI01
INTP2				P02
INTP3				P03
INTP4				P04
INTP5				P05
INTP6				P06
SI0	Input	Serial interface serial data input.	Input	P25/SB0
SI1				P20
SI2				P70/RxD
SO0	Output	Serial interface serial data output.	Input	P26/SB1
SO1				P21
SO2				P71/TxD
SB0	Input/ output	Serial interface serial data input/output.	Input	P25/SI0
SB1				P26/SO0
$\overline{\text{SCK0}}$	Input/ output	Serial interface serial clock input/ output	Input	P27
$\overline{\text{SCK1}}$				P22
$\overline{\text{SCK2}}$				P72/ASCK
STB	Output	Serial interface automatic transmit/receive strobe output.	Input	P23
BUSY	Input	Serial interface automatic transmit/receive busy input.	Input	P24
RxD	Input	Asynchronous serial interface serial data input.	Input	P70/SI2
TxD	Output	Asynchronous serial interface serial data output.	Input	P71/SO2
ASCK	Input	Asynchronous serial interface serial clock input.	Input	P72/SCK2
TI00	Input	External count clock input to the 16-bit timer (TM0)	Input	P00/INTP0
TI01		Capture trigger signal input to the capture register (CR00)		P01/INTP1
TI1		External count clock input to the 8-bit timer (TM1)		P33
TI2		External count clock input to the 8-bit timer (TM2)		P34
TO0	Output	16-bit timer (TM0) output (dual-function as 14-bit PWM output)	Input	P30
TO1		8-bit timer (TM1) output		P31
TO2		8-bit timer (TM2) output		P32
PCL	Output	Clock output (for main system clock, subsystem clock trimming).	Input	P35
BUZ	Output	Buzzer output.	Input	P36
RTP0 to RTP7	Output	Real-time output port by which data is output in synchronization with a trigger.	Input	P120 to P127
AD0 to AD7	Input/ output	Low-order address/data bus at external memory expansion.	Input	P40 to P47
A8 to A15	Output	High-order address bus at external memory expansion.	Input	P50 to P57
$\overline{\text{RD}}$	Output	External memory read operation strobe signal output.	Input	P64
$\overline{\text{WR}}$		External memory write operation strobe signal output.		P65

3.2 Other Pins (2/2)

Pin Name	I/O	Function	After Reset	Dual-Function Pin
$\overline{\text{WAIT}}$	Input	Wait insertion at external memory access.	Input	P66
ASTB	Output	Strobe output which latches the address information output at port 4 to access external memory.	Input	P67
ANI0 to ANI7	Input	A/D converter analog input.	Input	P10 to P17
ANO0, ANO1	Output	D/A converter analog output.	Input	P130, P131
AVREF0	Input	A/D converter reference voltage input.	—	—
AVREF1	Input	D/A converter reference voltage input.	—	—
AVDD	—	A/D converter analog power supply. Connected to V <sub>DD</sub>	—	—
AVSS	—	Ground potential of A/D converter and D/A converter. Connected to V <sub>SS</sub>	—	—
$\overline{\text{RESET}}$	Input	System reset input.	—	—
X1	Input	Main system clock oscillation crystal connection.	—	—
X2	—		—	—
XT1	Input	Subsystem clock oscillation crystal connection.	Input	P07
XT2	—		—	—
VDD	—	Positive power supply.	—	—
VSS	—	Ground potential.	—	—
IC	—	Internally connected. Connect directly to V <sub>SS</sub> .	—	—

**3.3 Pin I/O Circuits and Recommended Connection of Unused Pins**

The input/output circuit type of each pin and recommended connection of unused pins are shown in Table 3-1.  
For the input/output circuit configuration of each type, refer to **Figure 3-1**.

**Table 3-1. Input/Output Circuit Type of Each Pin (1/2)**

Pin Name	Input/output Circuit Type	I/O	Recommended Connection when Used	
P00/INTP0/TI00	2	Input	Connect to V <sub>SS</sub> .	
P01/INTP1/TI01	8-A	Input/output	Independently connect to V <sub>SS</sub> through resistor.	
P02/INTP2				
P03/INTP3				
P04/INTP4				
P05/INTP5				
P06/INTP6				
P07/XT1	16	Input	Connect to V <sub>DD</sub> .	
P10/ANI0 to P17/ANI7	11	Input/output	Independently connect to V <sub>DD</sub> or V <sub>SS</sub> through resistor.	
P20/SI1	8-A			
P21/SO1	5-A			
P22/SCK1	8-A			
P23/STB	5-A			
P24/BUSY	8-A			
P25/SI0/SB0	10-A			
P26/SO0/SB1				
P27/SCK0				
P30/TO0	5-A			
P31/TO1				
P32/TO2				
P33/TI1	8-A			
P34/TI2				
P35/PCL	5-A			
P36/BUZ				
P37				
P40/AD0 to P47/AD7	5-E			Independently connect to V <sub>DD</sub> through resistor.
P50/A8 to P57/A15	5-A			Independently connect to V <sub>DD</sub> or V <sub>SS</sub> through resistor.
P60 to P63	13-B			Independently connect to V <sub>DD</sub> through resistor.
P64/RD	5-A			Independently connect to V <sub>DD</sub> or V <sub>SS</sub> through resistor.
P65/WR				
P66/WAIT				
P67/ASTB				

Table 3-1. Input/Output Circuit Type of Each Pin (2/2)

Pin Name	Input/output Circuit Type	I/O	Recommended Connection when Used
P70/SI2/RxD	8-A	Input/output	Independently connect to V <sub>DD</sub> or V <sub>SS</sub> through resistor.
P71/SO2/TxD	5-A		
P72/SCK2/ASCK	8-A		
P120/RTP0 to P127/RTP7	5-A	Input/output	
P130/ANO0 , P131/ANO1	12-A	Input/output	Independently connect to V <sub>SS</sub> through resistor.
RESET	2	Input	—
XT2	16	—	Leave open.
AVREF0	—		Connect to V <sub>SS</sub> .
AVREF1			Connect to V <sub>DD</sub> .
AVDD			
AVSS			Connect to V <sub>SS</sub> .
IC			Connect to V <sub>SS</sub> directly.

Figure 3-1. Pin Input/Output Circuits (1/2)

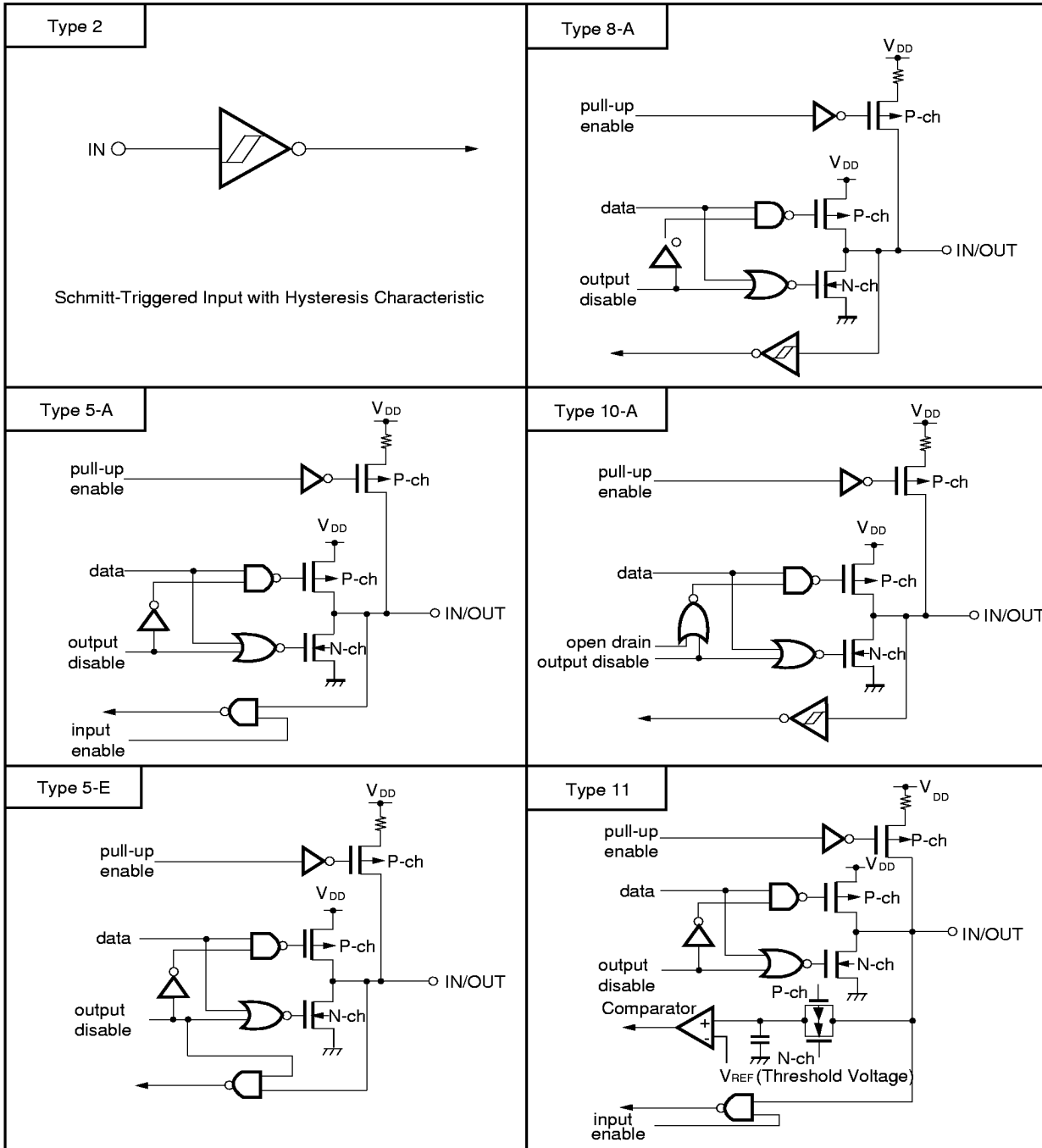
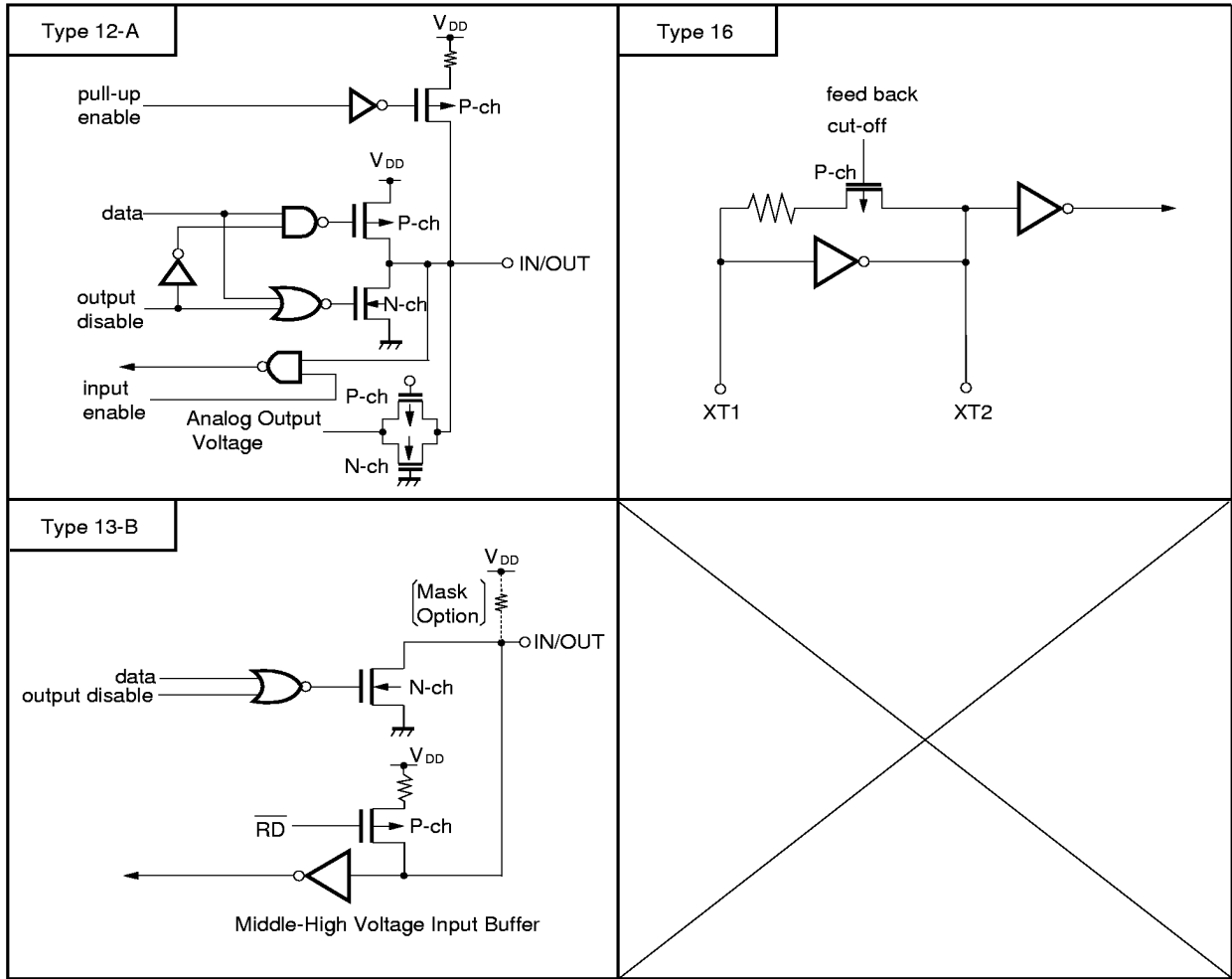



Figure 3-1. Pin Input/Output Circuits (2/2)



4. MEMORY SPACE

Figure 4-1 shows the μPD78052/78053/78054/78055/78056/78058 memory map.

Figure 4-1. Memory Map

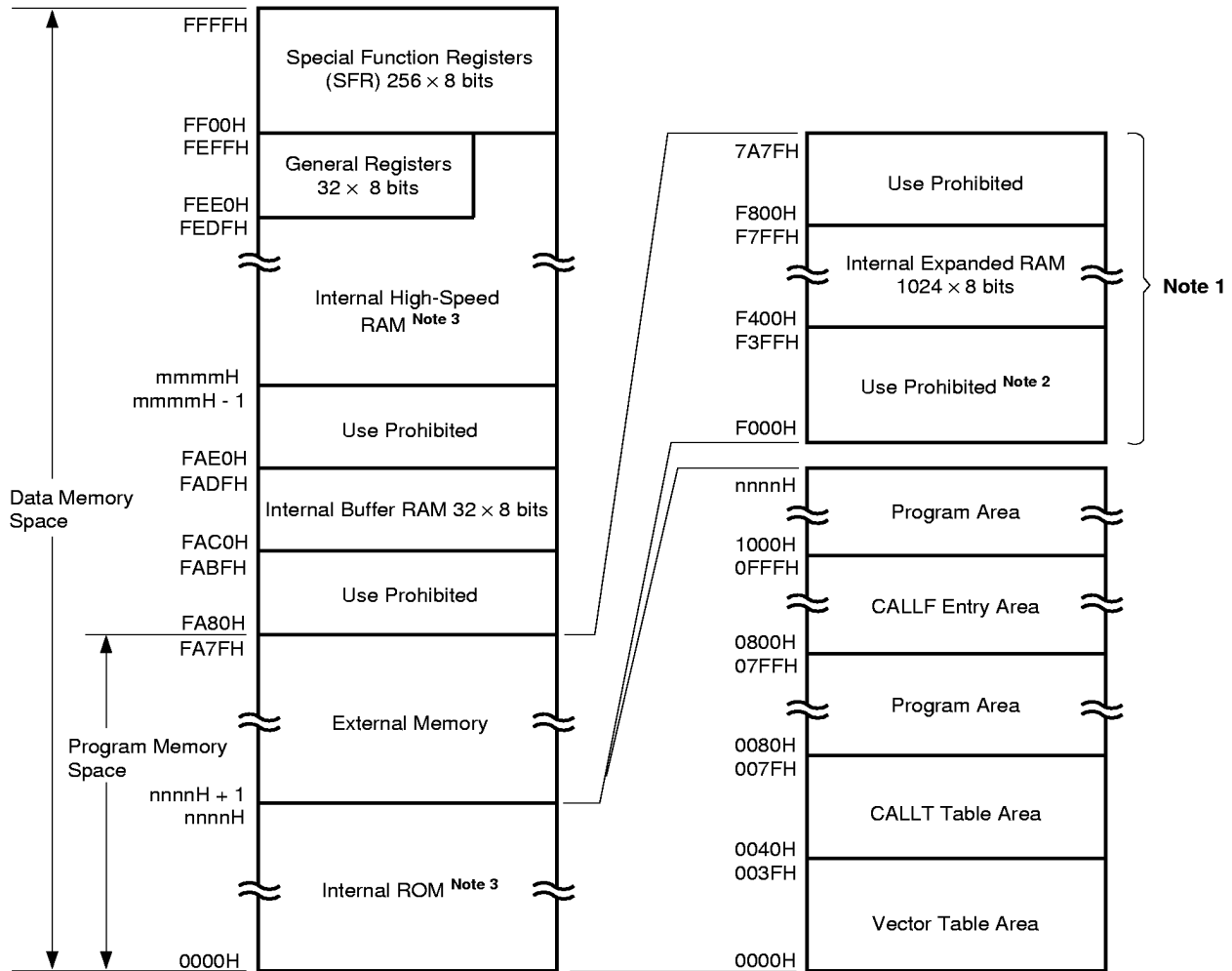

Relevant Product Name	Internal ROM Last Address nnnnH	Internal RAM First Address mmmmH
$\mu$ PD78052	3FFFH	FD00H
$\mu$ PD78053	5FFFH	FB00H
$\mu$ PD78054	7FFFH	
$\mu$ PD78055	9FFFH	
$\mu$ PD78056	BFFFH	
$\mu$ PD78058	EFFFH	

## 5. PERIPHERAL HARDWARE FUNCTION FEATURES

### 5.1 Ports

The following 3 types of I/O ports are available.

• CMOS input (P00, P07)	: 2
• CMOS input/output (P01 to P06, port 1 to port 5, P64 to P67, port 7, port 12, port 13)	: 63
• N-channel open-drain input/output (P60 to P63)	: 4
<b>Total</b>	<b>: 69</b>

**Table 5-1. Port Functions**

Name	Pin Name	Function
Port 0	P00, P07	Dedicated input port pins
	P01 to P06	Input/output port pins. Input/output specifiable bit-wise. When used as input port pins, on-chip pull-up resistor can be used by software.
Port 1	P10 to P17	Input/output port pins. Input/output specifiable bit-wise. When used as input port pins, on-chip pull-up resistor can be used by software.
Port 2	P20 to P27	Input/output port pins. Input/output specifiable bit-wise. When used as input port pins, on-chip pull-up resistor can be used by software.
Port 3	P30 to P37	Input/output port pins. Input/output specifiable bit-wise. When used as input port pins, on-chip pull-up resistor can be used by software.
Port 4	P40 to P47	Input/output port pins. Input/output specifiable in 8-bit units. When used as input port pins, on-chip pull-up resistor can be used by software. Test flag (KRIF) is set to 1 by falling edge detection.
Port 5	P50 to P57	Input/output port pins. Input/output specifiable bit-wise. When used as input port pins, on-chip pull-up resistor can be used by software. LED direct drive capability.
Port 6	P60 to P63	N-channel open-drain input/output port pins. Input/output specifiable bit-wise. On-chip pull-up resistor can be used by mask option. LED direct drive capability.
	P64 to P67	Input/output port pins. Input/output specifiable bit-wise. When used as input port pins, on-chip pull-up resistor can be used by software.
Port 7	P70 to P72	Input/output port pins. Input/output specifiable bit-wise. When used as input port pins, on-chip pull-up resistor can be used by software.
Port 12	P120 to P127	Input/output port pins. Input/output specifiable bit-wise. When used as input port pins, on-chip pull-up resistor can be used by software.
Port 13	P130, P131	Input/output port pins. Input/output specifiable bit-wise. When used as input port pins, on-chip pull-up resistor can be used by software.

**5.2 Clock Generator**

Two types of generators, a main system clock generator and a subsystem clock generator, are available. The minimum instruction execution time can also be changed.

- 0.4 μs/0.8 μs/1.6 μs/3.2 μs/6.4 μs/12.8 μs (main system clock: at 5.0-MHz operation)
- 122 μs (subsystem clock: at 32.768-kHz operation)

**Figure 5-1. Clock Generator Block Diagram**

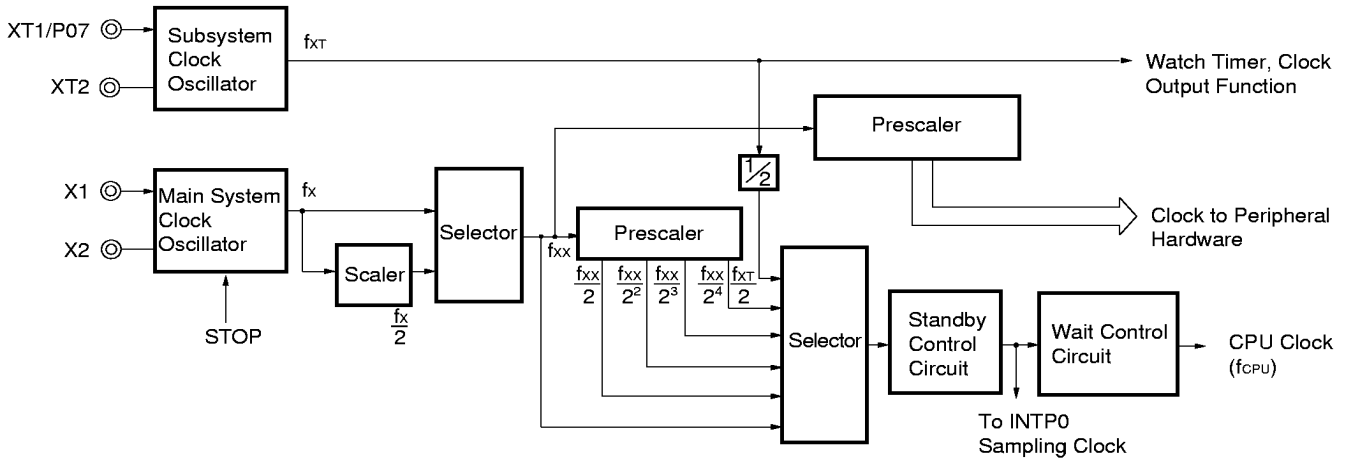

**5.3 Timer/Event Counter**

The μPD78052/78053/78054/78055/78056/78058 incorporate 5 channels of the timer/event counter.

- 16-bit timer/event counter : 1 channel
- 8-bit timer/event counter : 2 channels
- Watch timer : 1 channel
- Watchdog timer : 1 channel

**Table 5-2. Operation of Timer/Event Counter**

	16-Bit Timer/Event Counter	8-Bit Timer/Event Counter	Watch Timer	Watchdog Timer
Operation mode				
Interval timer	1 channel	2 channels	1 channel	1 channel
External event counter	1 channel	2 channels	—	—
Function				
Timer output	1 output	2 outputs	—	—
PWM output	1 output	—	—	—
Pulse amplitude measurement	2 inputs			
Square wave output	1 output	2 outputs	—	—
Ono-shot pulse output	1 output	—	—	—
Interrupt source	2	2	1	1
Test input	—	—	1 input	—

Figure 5-2. 16-Bit Timer/Event Counter Block Diagram

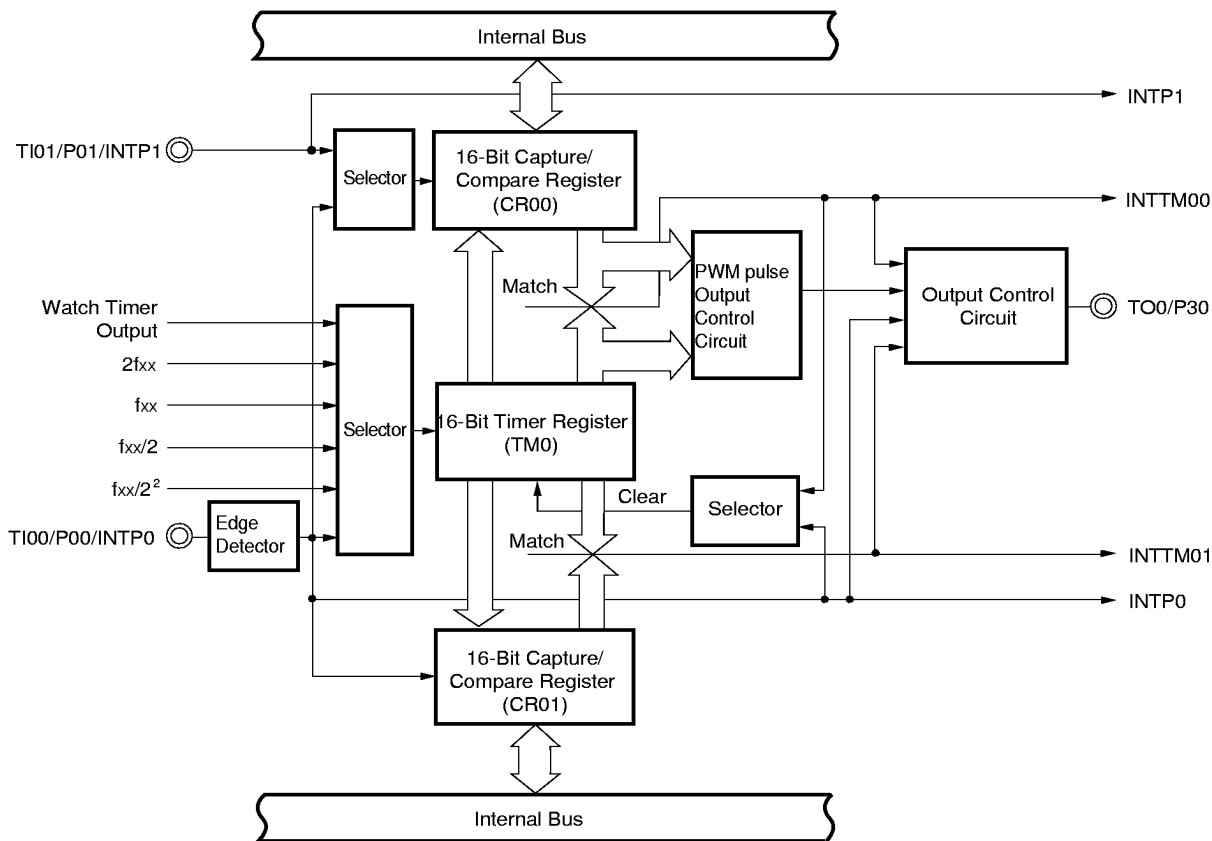

Figure 5-3. 8-Bit Timer/Event Counter Block Diagram

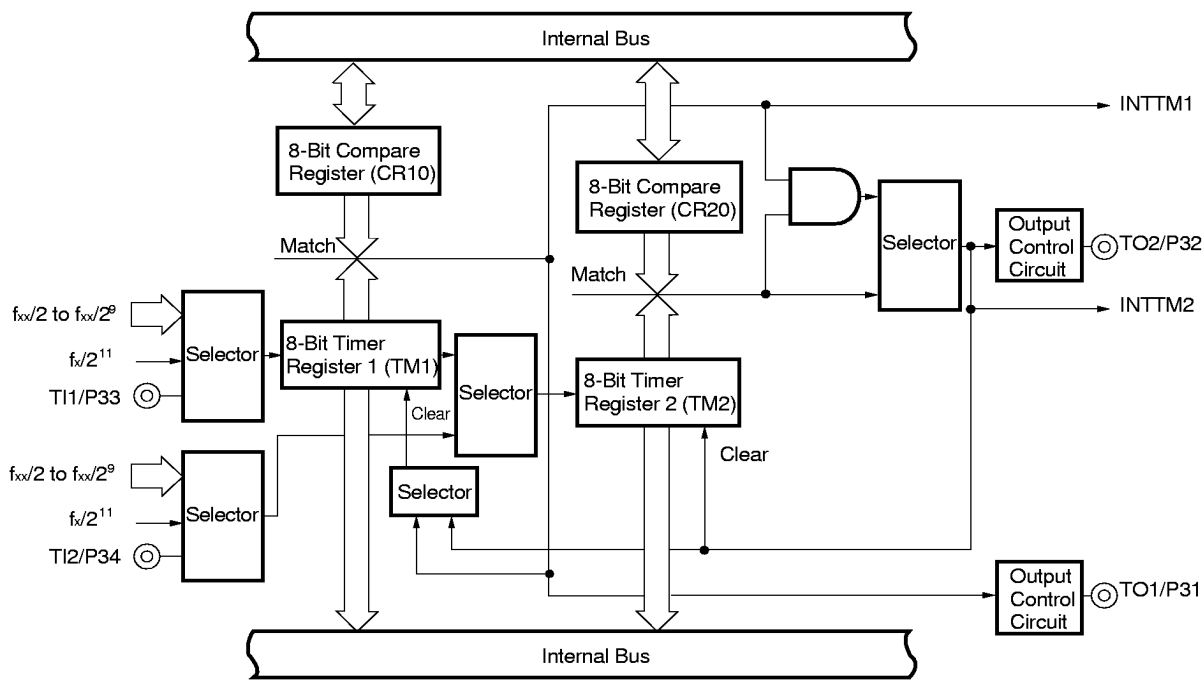

Figure 5-4. Watch Timer Block Diagram

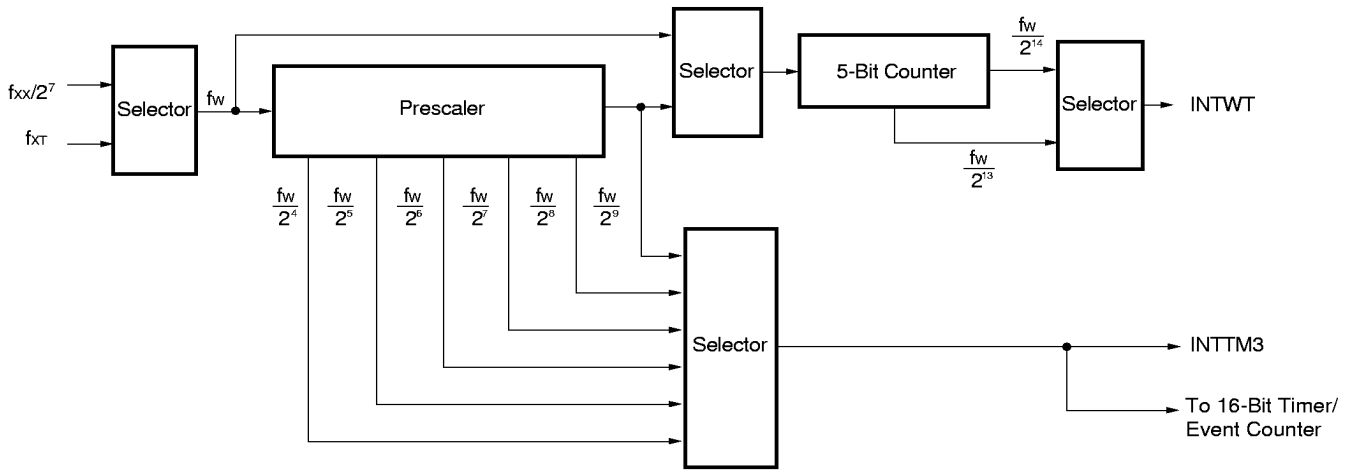
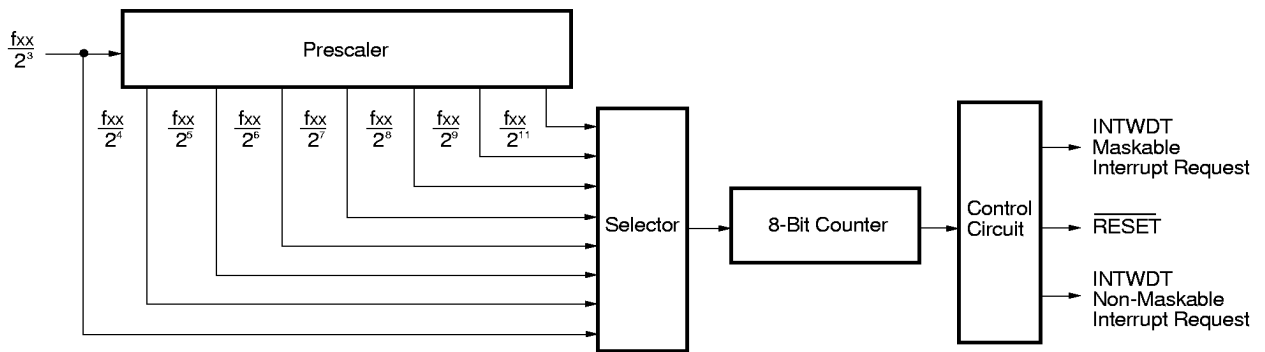

Figure 5-5. Watchdog Timer Block Diagram



**5.4 Clock Output Control Circuit**

The clock with the following frequency can be output as a clock output.

- 19.5 kHz/39.1 kHz/78.1 kHz/156 kHz/313 kHz/625 kHz/1.25 MHz/2.5 MHz/5.0 MHz (main system clock: at 5.0-MHz operation)
- 32.768 kHz (subsystem clock: at 32.768-kHz operation)

**Figure 5-6. Clock Output Control Circuit Configuration**

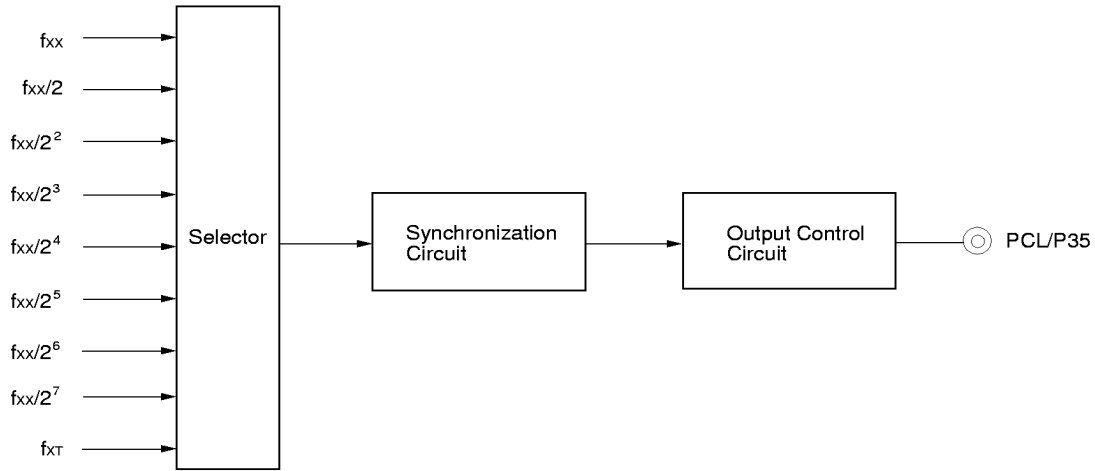

**5.5 Buzzer Output Control Circuit**

The clock with the following frequency can be output as a buzzer output.

- 1.2 kHz/2.4 kHz/4.9 kHz/9.8 kHz (main system clock: at 5.0-MHz operation)

**Figure 5-7. Buzzer Output Control Circuit Block Diagram**

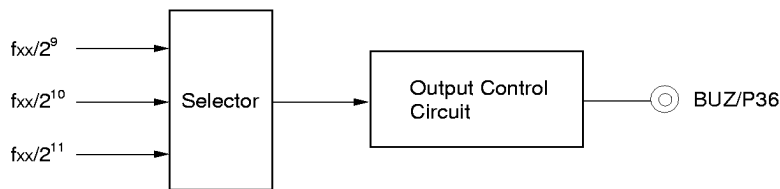



5.6 A/D Converter

An A/D converter of 8-bit resolution × 8 channels is incorporated.

The following two types of the A/D conversion operation start-up methods are available.

- Hardware start
- Software start

Figure 5-8. A/D Converter Block Diagram

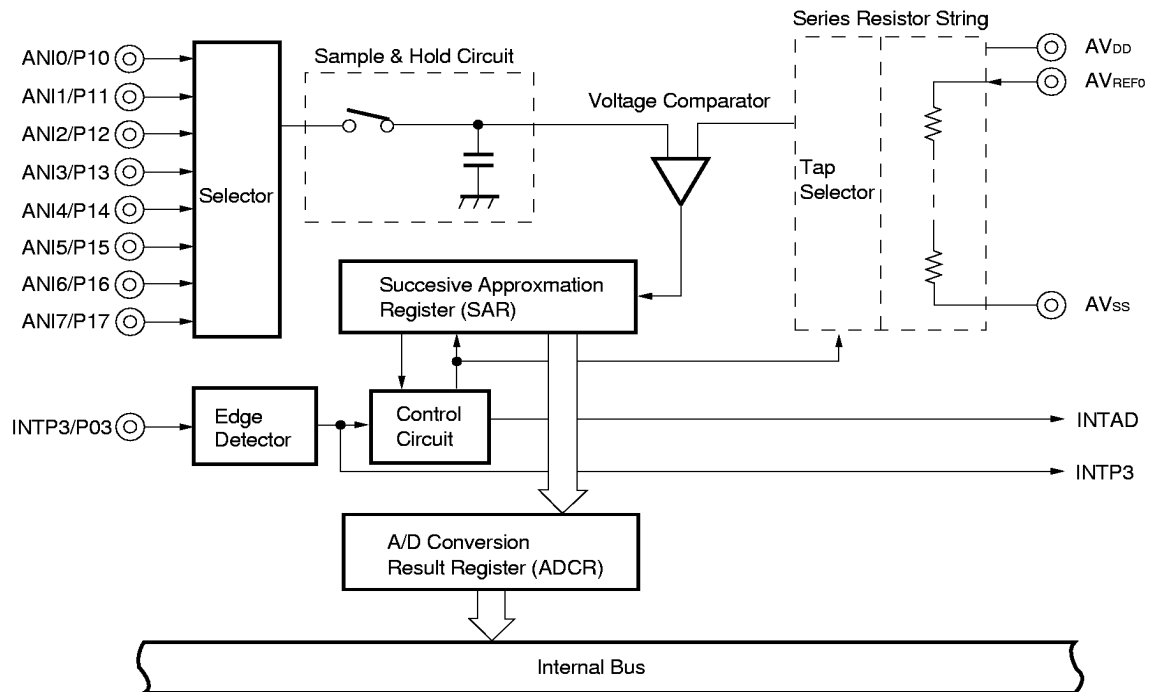

5.7 D/A Converter

A D/A converter of 8-bit resolution × 2 channels is available.  
Conversion method is R-2R resistor ladder method.

Figure 5-9. D/A Converter Block Diagram

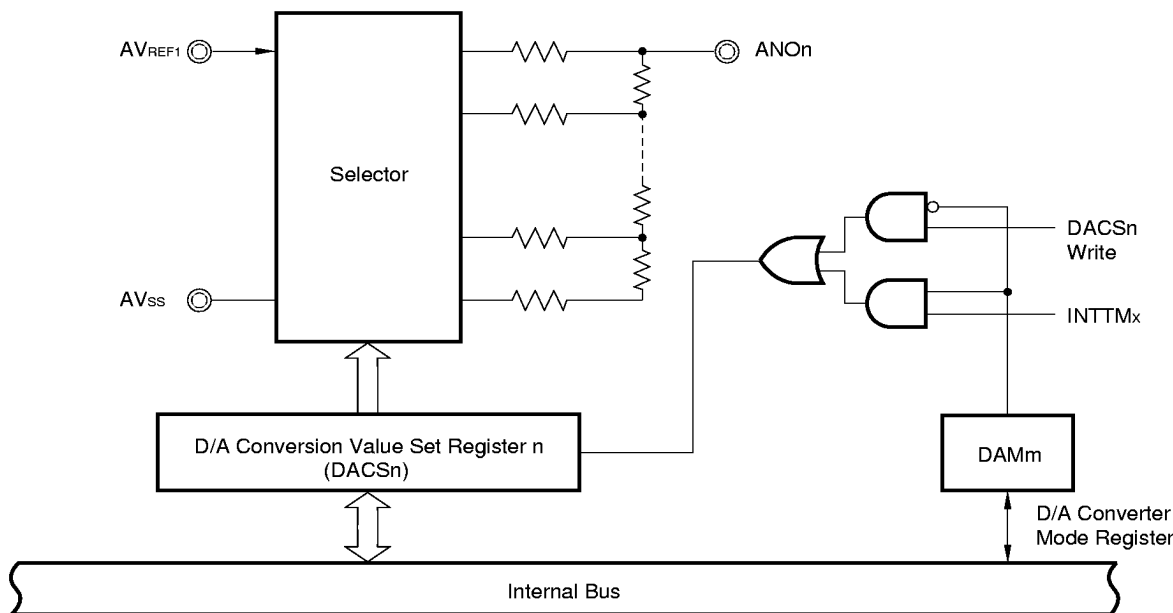

n = 0, 1  
m = 4, 5  
x = 1, 2

5.8 Serial Interfaces

3 channels of the clocked serial interface are incorporated.

- Serifal interface channel 0
- Serifal interface channel 1
- Serifal interface channel 2

Table 5-3. Types and Functions of Serial Interface

Function	Serial Interface Channel 0	Serial Interface Channel 1	Serial Interface Channel 2
3-wire serial I/O mode	○ (MSB/LSB first switchable)	○ (MSB/LSB first switchable)	○ (MSB/LSB first switchable)
3-wire serial I/O mode with automatic transmit/receive function	—	○ (MSB/LSB first switchable)	—
SBI (serial bus interface) mode	○ (MSB first)	—	—
2-wire serial I/O mode	○ (MSB first)	—	—
3-wire serial I/O mode with automatic transmit/receive function	—	—	○ (Dedicated baud rate generator incorporated)

Figure 5-10. Serial Interface Channel 0 Block Diagram

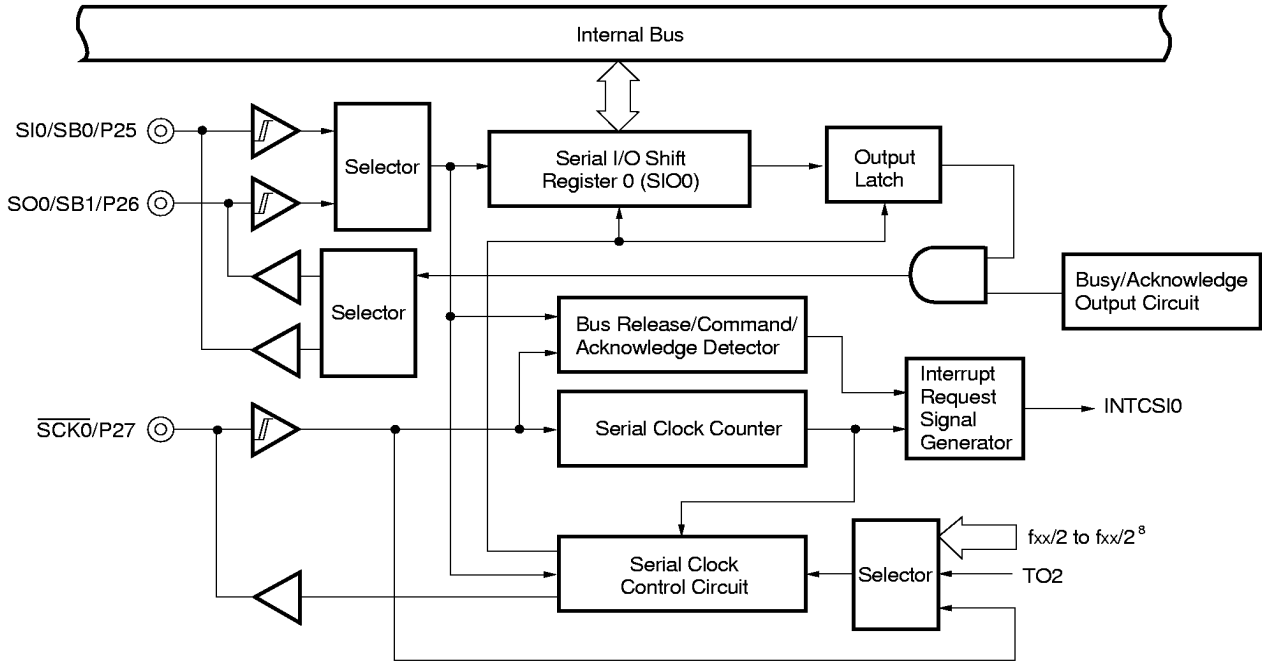

Figure 5-11. Serial Interface Channel 1 Block Diagram

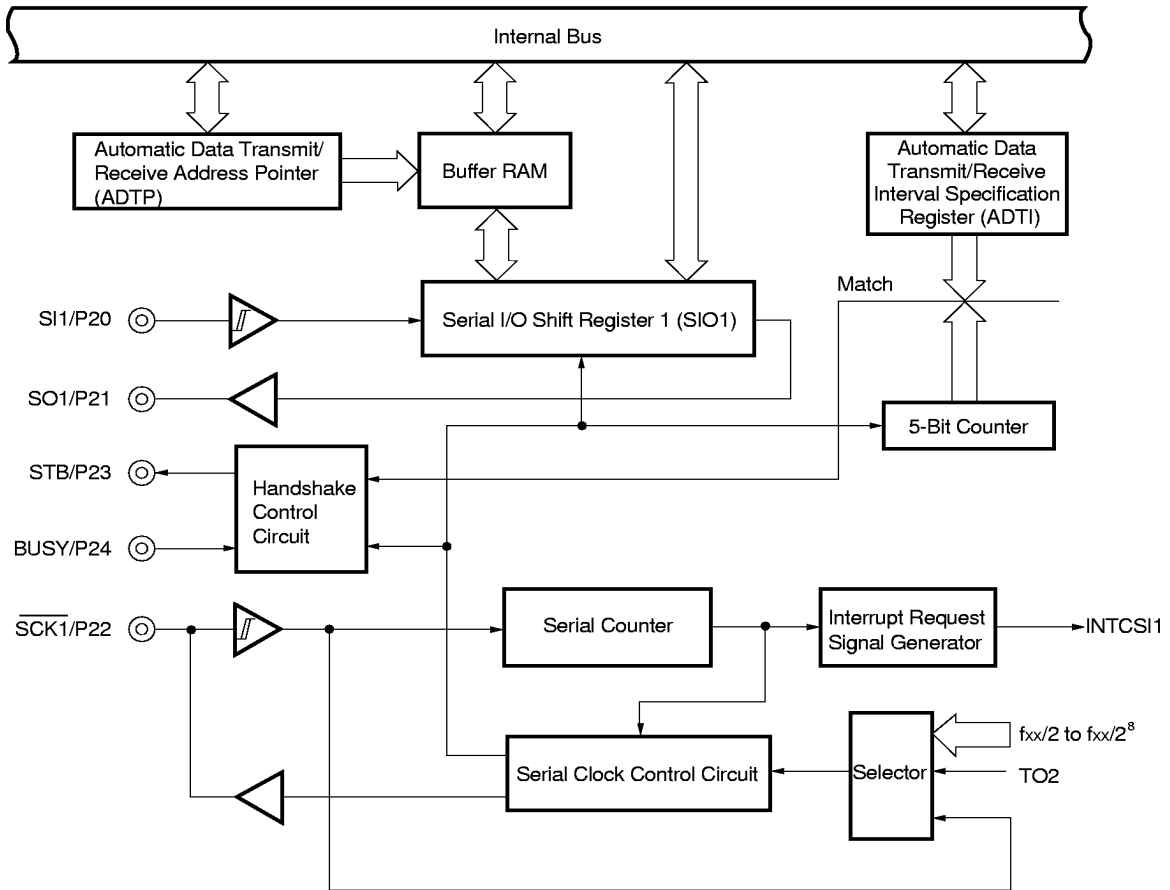
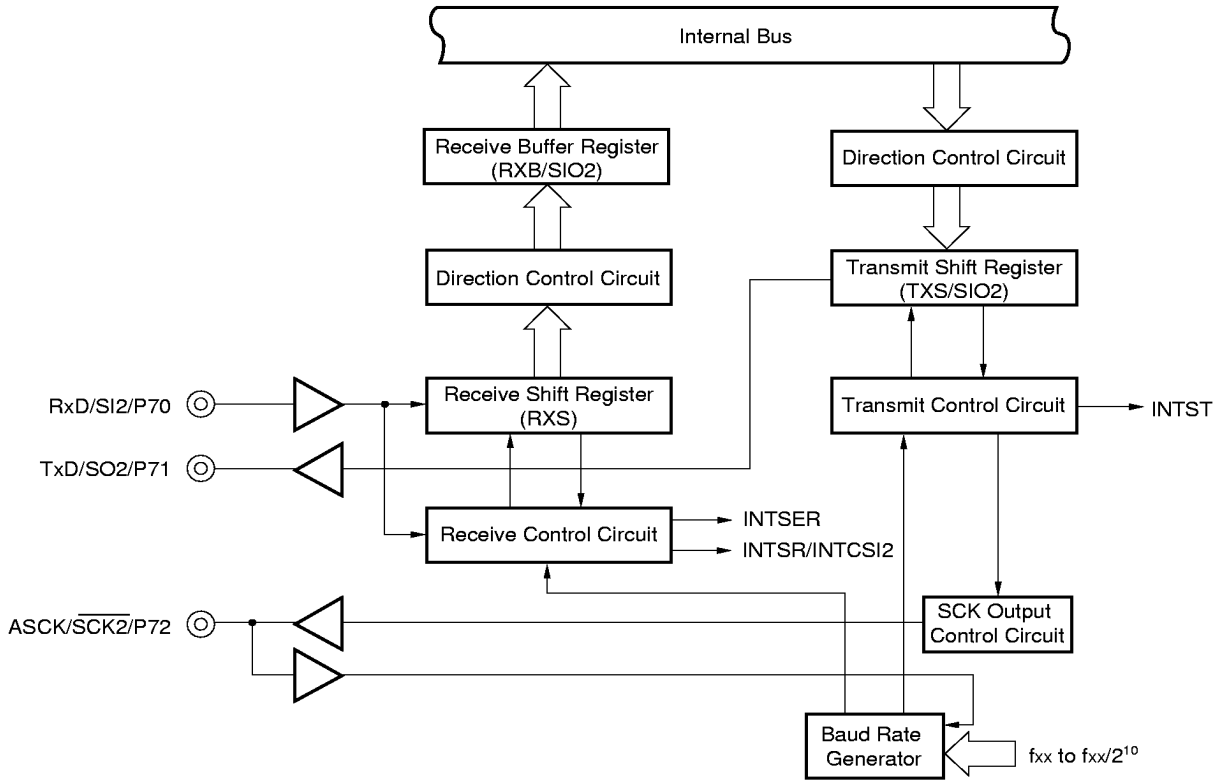

Figure 5-12. Serial Interface Channel 2 Block Diagram



5.9 Real-Time Output Port Functions

Data set previously in the real-time output buffer register is transferred to the output latch by hardware concurrently with timer interrupt and external interrupt generation in order to output to off-chip. This is real-time output function. And pins to output to off-chip are called real-time output ports.

By using a real-time output port, a signal which has no jitter can be output. This is most applicable to control of stepping motor, etc.

Figure 5-13. Real-Time Output Port Block Diagram

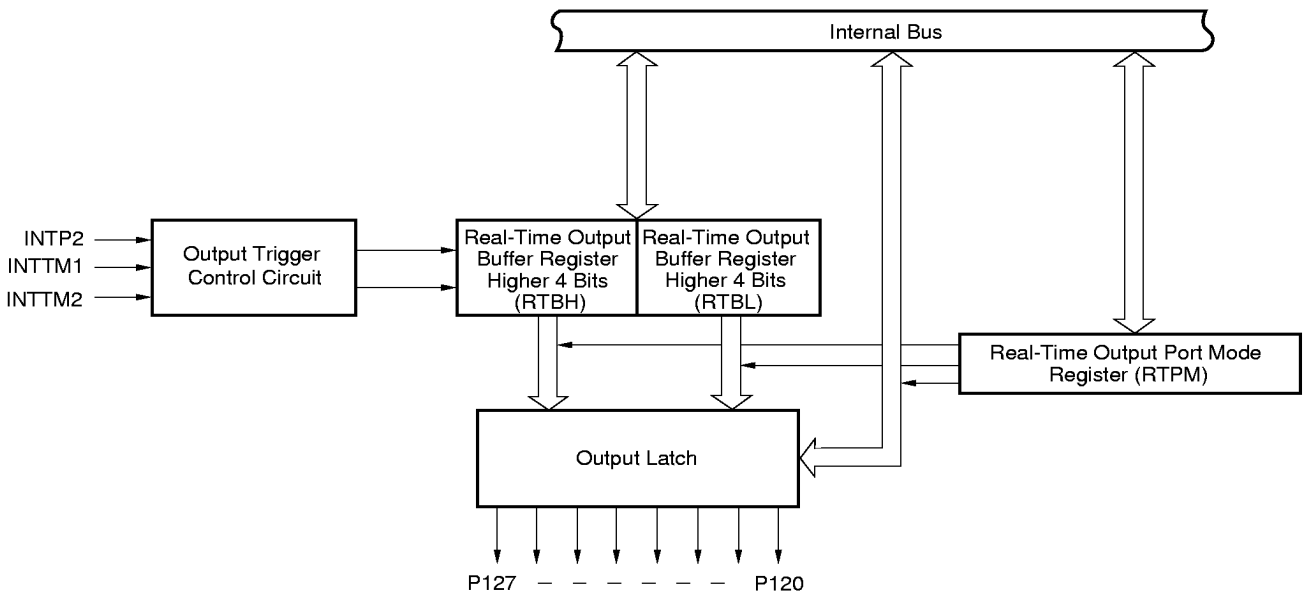

6. INTERRUPT FUNCTIONS AND TEST FUNCTIONS

6.1 Interrupt Functions

There are interrupt functions, 22 sources of three different kinds, as shown below.

- Non-maskable : 1
- Maskable : 20
- Software : 1

The following table shows the interrupt source list.

Table 6-1. Interrupt Source List (1/2)

Interrupt Type	Default <sup>Note 1</sup> Priority	Interrupt Source		Internal/ External	Vector Table Address	Basic Configuration Type <sup>Note 2</sup>			
		Name	Trigger						
Non-maskable	—	INTWDT	Watchdog timer overflow (watchdog timer mode 1 selected)	Internal	0004H	(A)			
Maskable	0	INTWDT	Watchdog timer overflow (interval timer mode selected)			External	0006H	(B)	
	1	INTP0	Pin input edge detection	0008H	(C)				
	2	INTP1							
	3	INTP2							
	4	INTP3							
	5	INTP4							
	6	INTP5							
	7	INTP6							
	8	INTCSI0						End of serial interface channel 0 transfer	Internal
	9	INTCSI1	End of serial interface channel 1 transfer						
	10	INTSER	Generation of serial interface channel 2 UART receive error						
	11	INTSR	End of serial interface channel 2 UART reception	001AH					
		INTCSI2	End of serial interface channel 2 3-wire transfer						
	12	INTST	End of serial interface channel 2 UART transmission	001CH					

- Notes**
1. The default priority is a priority order when two or more maskable interrupt requests are generated simultaneously. 0 is the highest order and 18, the lowest.
  2. Basic configuration types (A) to (E) correspond to A to E in Figure 6-1, respectively.

Table 6-1. Interrupt Source List (2/2)

Interrupt Type	Default <sup>Note 1</sup> Priority	Interrupt Source		Internal/ External	Vector Table Address	Basic Configuration Type <sup>Note 2</sup>
		Name	Trigger			
Maskable	13	INTTM3	Reference time interval signal from watch timer	Internal	001EH	(B)
	14	INTTM00	Generation of match signal of 16-bit timer register and capture/compare register (CR00)		0020H	
	15	INTTM01	Generation of match signal of 16-bit timer register and capture/compare register (CR01)		0022H	
	16	INTTM1	Generation of match signal of 8-bit timer/event counter 1		0024H	
	17	INTTM2	Generation of match signal of 8-bit timer/event counter 2		0026H	
	18	INTAD	End of conversion by A/D converter		0028H	
Software	—	BRK	BRK instruction execution	—	003EH	(E)

- Notes**
1. The default priority is a priority order when two or more maskable interrupts are generated simultaneously. 0 is the highest order and 18, the lowest.
  2. Basic configuration types (A) to (E) correspond to (A) to (E) in Figure 6-1, respectively.

Figure 6-1. Interrupt Function Basic Configuration(1/2)

(A) Internal non-maskable interrupt

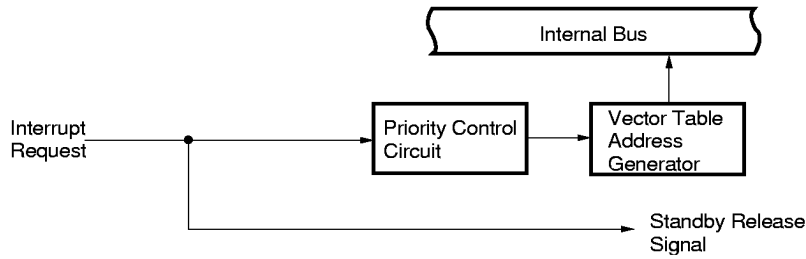

(B) Internal maskable interrupt

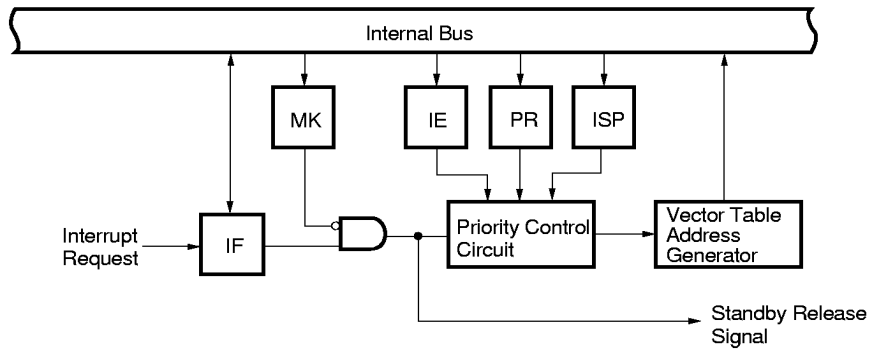

(C) External maskable interrupt (INTP0)

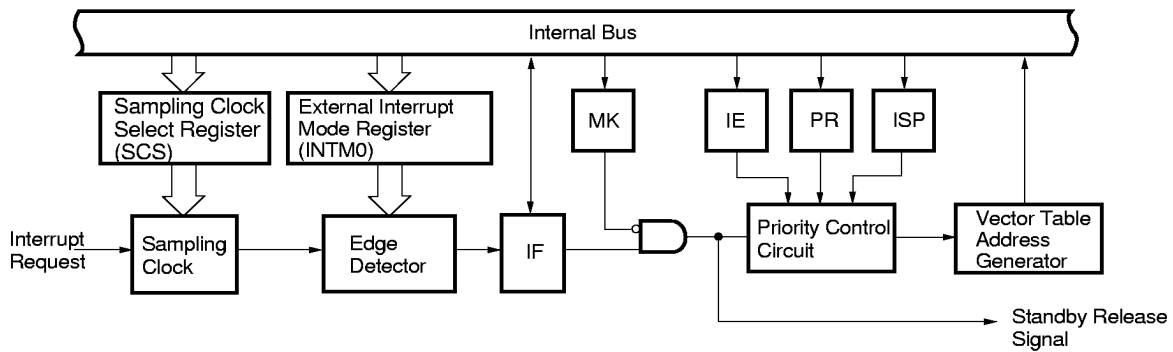
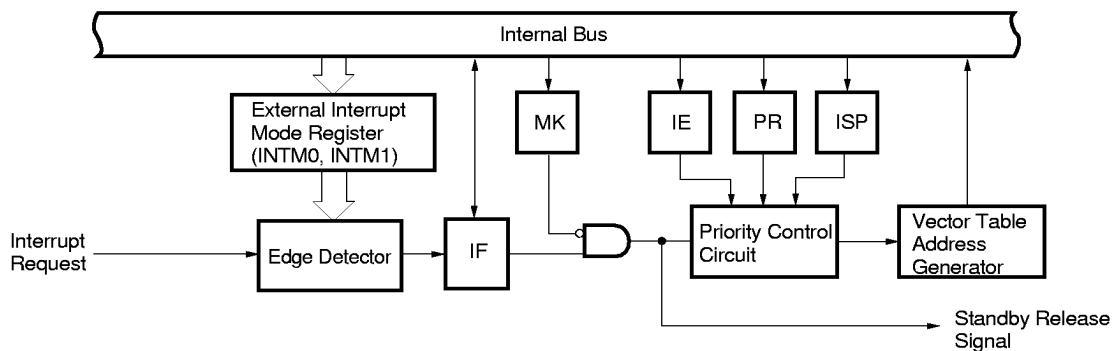
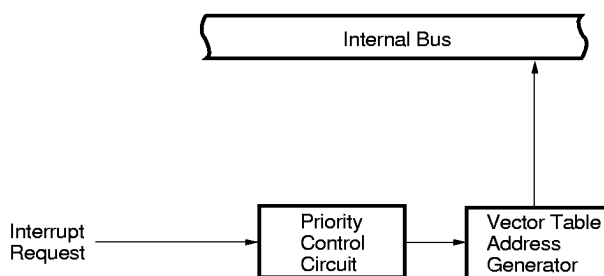

Figure 6-1. Interrupt Function Basic Configuration(2/2)

(D) External maskable interrupt (except INTP0)



(E) Software interrupt



- IF : Interrupt request flag
- IE : Interrupt enable flag
- ISP : In-service priority flag
- MK : Interrupt mask flag
- PR : Priority specification flag



6.2 Test Functions

There are two test functions as shown in Table 6-2.

Table 6-2. Test Input Source List

Test Input Source		Internal/External
Name	Trigger	
INTWT	Watch timer overflow	Internal
INTPT4	Port 4 falling edge detection	External

Figure 6-2. Test Function Basic Configuration

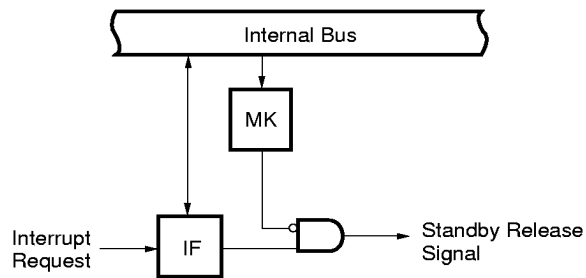

IF : Test input flag  
 MK : Test mask flag

### 7. EXTERNAL DEVICE EXPANSION FUNCTIONS

The external device expansion functions connect external devices to areas other than the internal ROM, RAM and SFR. Ports 4 to 6 are used for external device connection.

### 8. STANDBY FUNCTION

There are the following two standby functions to reduce the system power consumption.

- HALT mode : The CPU operating clock is stopped.  
The average consumption current can be reduced by intermittent operation in combination with the normal operating mode.
- STOP mode : The main system clock oscillation is stopped. The whole operation by the main system clock is stopped, so that the system operates with ultra-low power consumption using only the subsystem clock.

Figure 8-1. Stand-by Function

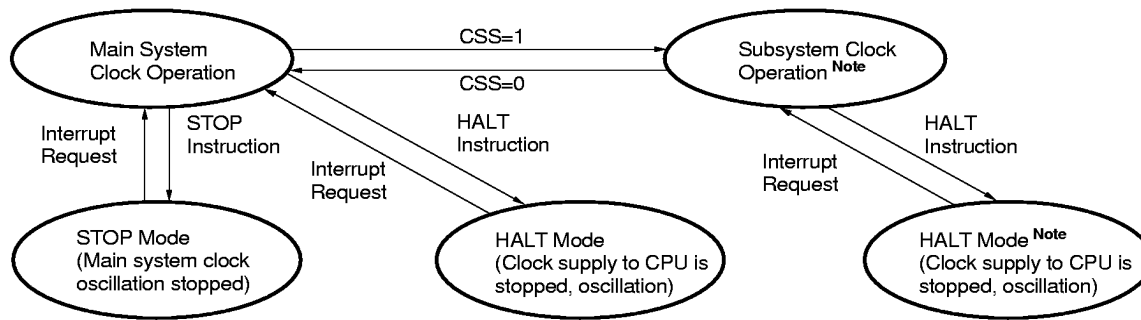

**Note** The power consumption can be reduced by stopping the main system clock. When the CPU is operating on the subsystem clock, set the bit 7 (MCC) of the processor clock control register (PCC) to stop the main system clock. The STOP instruction cannot be used.

**Caution** When the main system clock is stopped and the system is operated by the subsystem clock, the subsystem clock should be switched again to the main system clock after the oscillation stabilization time is secured in software.

### 9. RESET FUNCTION

There are the following two reset methods.

- External reset input by  $\overline{\text{RESET}}$  pin
- Internal reset by watchdog timer hung-up time detection

10. INSTRUCTION SET

(1) 8-bit instruction

MOV, XCH, ADD, ADDC, SUB, SUBC, AND, OR, XOR, CMP, MULU, DIVUW, INC, DEC, ROR, ROL, RORC, ROLC, ROR4, ROL4, PUSH, POP, DBNZ

Second Operand / First Operand	#byte	A	r Note	sfr	saddr	!addr16	PSW	[DE]	[HL]	[HL + Byte] [HL + B] [HL + C]	\$addr16	1	None
A	ADD ADDC SUB SUBC AND OR XOR CMP		MOV XCH ADD ADDC SUB SUBC AND OR XOR CMP	MOV XCH	MOV XCH ADD ADDC SUB SUBC AND OR XOR CMP	MOV XCH ADD ADDC SUB SUBC AND OR XOR CMP	MOV	MOV XCH	MOV XCH ADD ADDC SUB SUBC AND OR XOR CMP	MOV XCH ADD ADDC SUB SUBC AND OR XOR CMP		ROR ROL RORC ROLC	
r	MOV	MOV ADD ADDC SUB SUBC AND OR XOR CMP											INC DEC
B, C											DBNZ		
sfr	MOV	MOV											
saddr	MOV ADD ADDC SUB SUBC AND OR XOR CMP	MOV									DBNZ		INC DEC
!addr16		MOV											
PSW	MOV	MOV											PUSH POP
[DE]		MOV											
[HL]		MOV											ROR4 ROL4
[HL + Byte] [HL + B] [HL + C]		MOV											
X													MULU
C													DIVUW

Note Except r = A

(2) 16-bit instruction

MOV, XCHW, ADDW, SUBW, CMPW, PUSH, POP, INCW, DECW

Second instruction First instruction	#word	AX	rp Note	sfrp	saddrp	laddr16	SP	None
AX	ADDW SUBW CMPW		MOVW XCHW	MOVW	MOVW	MOVW	MOVW	
rp	MOVW	MOVW Note						INCW, DECW PUSH, POP
sfrp	MOVW	MOVW						
saddrp	MOVW	MOVW						
laddr16		MOVW						
SP	MOVW	MOVW						

Note Only when rp = BC, DE or HL

(3) Bit manipulation instruction

MOV1, AND1, OR1, XOR1, SET1, CLR1, NOT1, BT, BF, BTCLR

Second instruction First instruction	A.bit	sfr.bit	saddr.bit	PSW.bit	[HL].bit	CY	\$addr16	None
A.bit						MOV1	BT BF BTCLR	SET1 CLR1
sfr.bit						MOV1	BT BF BTCLR	SET1 CLR1
saddr.bit						MOV1	BT BF BTCLR	SET1 CLR1
PSW.bit						MOV1	BT BF BTCLR	SET1 CLR1
[HL].bit						MOV1	BT BF BTCLR	SET1 CLR1
CY	MOV1 AND1 OR1 XOR1	MOV1 AND1 OR1 XOR1	MOV1 AND1 OR1 XOR1	MOV1 AND1 OR1 XOR1	MOV1 AND1 OR1 XOR1			SET1 CLR1 NOT1

(4) Call instruction/branch instruction

CALL, CALLF, CALLT, BR, BC, BNC, BZ, BNZ, BT, BF, BTCLR, DBNZ

Second instruction First instruction	AX	laddr16	laddr11	[addr5]	\$addr16
Basic instruction	BR	CALL BR	CALLF	CALLT	BR, BC, BNC BZ, BNZ
Compound instruction					BT, BF BTCLR DBNZ

**(5) Other instructions**

ADJBA, ADJBS, BRK, RET, RETI, RETB, SEL, NOP, EI, DI, HALT, STOP

11. ELECTRICAL SPECIFICATIONS

Absolute Maximum Ratings (T<sub>A</sub> = 25°C)

Parameter	Symbol	Test Conditions	Rating	Unit	
Supply voltage	V <sub>DD</sub>		-0.3 to +7.0	V	
	AV <sub>DD</sub>		-0.3 to V <sub>DD</sub> + 0.3	V	
	AV <sub>REF0</sub>		-0.3 to V <sub>DD</sub> + 0.3	V	
	AV <sub>REF1</sub>		-0.3 to V <sub>DD</sub> + 0.3	V	
	AV <sub>SS</sub>		-0.3 to +0.3	V	
Input voltage	V <sub>I1</sub>	P00 to P07, P10 to P17, P20 to P27, P30 to P37, P40 to P47, P50 to P57, P64 to P67, P70 to P72, P120 to P127, P130, P131, X1, X2, XT2, RESET	-0.3 to V <sub>DD</sub> + 0.3	V	
	V <sub>I2</sub>	P60 to P63 N-ch Open-drain	-0.3 to +16	V	
Output voltage	V <sub>O</sub>		-0.3 to V <sub>DD</sub> + 0.3	V	
Analog input voltage	V <sub>AN</sub>	P10 to P17 Analog input pin	AV <sub>SS</sub> - 0.3 to AV <sub>REF0</sub> + 0.3	V	
Output current high	I <sub>OH</sub>	1 pin	-10	mA	
		P01 to P06, P30 to P37, P56, P57, P60 to P67, P120 to P127 total	-15	mA	
		P10 to P17, P20 to P27, P40 to P47, P50 to P55, P70 to P72, P130, P131 total	-15	mA	
Output current low	I <sub>OL</sub> <b>Note 2</b>	1 pin	Peak value	30	mA
			r.m.s. value	15	mA
		P50 to P55 total	Peak value	100	mA
			r.m.s. value	70	mA
		P56, P57, P60 to P63 total	Peak value	100	mA
			r.m.s. value	70	mA
		P10 to P17, P20 to P27, P40 to P47, P70 to P72, P130, P131 total	Peak value	50	mA
			r.m.s. value	20	mA
P01 to P06, P30 to P37, P64 to P67, P120 to P127 total	Peak value	50	mA		
	r.m.s. value	20	mA		
Operating ambient temperature	T <sub>A</sub>		-40 to +85	°C	
Storage temperature	T <sub>stg</sub>		-65 to +150	°C	

**Note** r.m.s value should be calculated as follows: [r.m.s value] = [Peak value] × √duty

**Caution** Product quality may suffer if the absolute maximum rating is exceeded for even a single parameter or even momentarily. That is, the absolute maximum ratings are rated values at which the product is on the verge of suffering physical damage, and therefore the product must be used under conditions which ensure that the absolute maximum ratings are not exceeded.

Main System Clock Oscillation Circuit Characteristics (T<sub>A</sub> = -40 to +85°C, V<sub>DD</sub> = 2.0 to 6.0 V)

Resonator	Recommended Circuit	Parameter	Test Conditions	MIN.	TYP.	MAX.	Unit
Ceramic resonator		Oscillator frequency (fx) <b>Note 1</b>	V <sub>DD</sub> = Oscillator voltage range	1.0		5.0	MHz
		Oscillation stabilization time <b>Note 2</b>	After V <sub>DD</sub> reaches oscillator voltage range MIN.			4	ms
Crystal resonator		Oscillator frequency (fx) <b>Note 1</b>		1.0		5.0	MHz
		Oscillation stabilization time <b>Note 2</b>	V <sub>DD</sub> = 4.5 to 6.0 V			10 30	ms
External clock		X1 input frequency (fx) <b>Note 1</b>		1.0		5.0	MHz
		X1 input high/low level width (t <sub>xH</sub> , t <sub>xL</sub> )		85		500	ns

**Notes** 1. Indicates only oscillation circuit characteristics. Refer to **AC Characteristics** for instruction execution time.

2. Time required to stabilize oscillation after reset or STOP mode release.

**Cautions** 1. When using the main system clock oscillator, wiring in the area enclosed with the broken line should be carried out as follows to avoid an adverse effect from wiring capacitance.

- Wiring should be as short as possible.
- Wiring should not cross other signal lines.
- Wiring should not be placed close to a varying high current.
- The potential of the oscillator capacitor ground should be the same as V<sub>ss</sub>.
- Do not ground wiring to a ground pattern in which a high current flows.
- Do not fetch a signal from the oscillator.

2. When the main system clock is stopped and the system is operated by the subsystem clock, the subsystem clock should be switched again to the main system clock after the oscillation stabilization time is secured in software.

Subsystem Clock Oscillation Circuit Characteristics (T<sub>A</sub> = -40 to +85°C, V<sub>DD</sub> = 2.0 to 6.0 V)

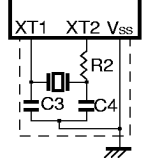
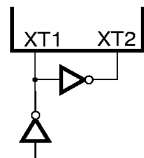
Resonator	Recommended Circuit	Parameter	Test Conditions	MIN.	TYP.	MAX.	Unit
Crystal resonator		Oscillator frequency (f <sub>XT</sub> ) <b>Note 1</b>		32	32.768	35	kHz
		Oscillation stabilization time <b>Note 2</b>	V <sub>DD</sub> = 4.5 to 6.0 V		1.2	2	s
External clock		XT1 input frequency (f <sub>XT</sub> ) <b>Note 1</b>		32		100	
		XT1 input high/low level width (t <sub>XTH</sub> , t <sub>XTL</sub> )		5		15	μs

- ★ **Notes**
1. Indicates only oscillation circuit characteristics. Refer to **AC Characteristics** for instruction execution time.
  2. Time required to stabilize oscillation after V<sub>DD</sub> reaches MIN in the oscillator voltage range.

**Cautions** 1. When using the subsystem clock oscillator, wiring in the area enclosed with the broken line should be carried out as follows to avoid an adverse effect from wiring capacitance.

- Wiring should be as short as possible.
  - Wiring should not cross other signal lines.
  - Wiring should not be placed close to a varying high current.
  - The potential of the oscillator capacitor ground should be the same as V<sub>ss</sub>.
  - Do not ground wiring to a ground pattern in which a high current flows.
  - Do not fetch a signal from the oscillator.
2. The subsystem clock oscillation circuit is a circuit with a low amplification level, more prone to misoperation due to noise than the main system clock.



**Recommended Oscillation Circuit Constant**

(1) μPD78052, 78053, 78054, 78055, 78056

**Main system clock: ceramic resonator (T<sub>A</sub> = -40 to +85°C)**

Manufacturer	Product Name	Frequency (MHz)	Recommended Circuit constant		Oscillator Voltage range		Remarks
			C1 (pF)	C2 (pF)	MIN. (V)	MAX. (V)	
Murata Mfg. Co., Ltd.	CSA5.00MG	5.00	30	30	2.0	6.0	
	CST5.00MGW	5.00	On chip	On chip	2.0	6.0	Capacitor on chip
Kyocera Corp.	KBR-5.0MSA	5.00	33	33	2.0	6.0	Lead type
	KBR-5.0MKS	5.00	On chip	On chip	2.0	6.0	Capacitor on chip, lead type
	KBR-5.0MWS	5.00	On chip	On chip	2.0	6.0	Capacitor on chip, lead type
	PBRC 5.00A	5.00	33	33	2.0	6.0	Chip type
TDK Corp.	CCR4.0MC3	4.00	On chip	On chip	2.0	6.0	Capacitor on chip
	CCR5.0MC3	5.00	On chip	On chip	2.0	6.0	Capacitor on chip

**Main system clock: crystal resonator (T<sub>A</sub> = -10 to +70°C)**

Manufacturer	Product Name	Frequency (MHz)	Recommended Circuit Constant			Oscillator Voltage Range	
			C1 (pF)	C2 (pF)	R1 (kΩ)	MIN. (V)	MAX. (V)
Daishinku Corp.	SMD-49	3.579545	27	27	1.5	2.0	6.0

**Subsystem clock: crystal resonator (T<sub>A</sub> = -10 to +70°C)**

Manufacturer	Product Name	Frequency (MHz)	Recommended Circuit Constant			Oscillator Voltage Range	
			C3 (pF)	C4 (pF)	R2 (kΩ)	MIN. (V)	MAX. (V)
Daishinku Corp.	DT-38 (1TA252E00)	32.768	27	20	330	2.0	6.0

**Caution** The oscillation circuit constants and oscillation voltage range indicate conditions for stable oscillation. However, they do not guarantee accuracy of the oscillation frequency. If the application circuit requires accuracy of the oscillation frequency, it is necessary to set the oscillation frequency in the application circuit. For this, it is necessary to directly contact the manufacturer of the resonator being used.

(2) μPD78058

Main system clock: ceramic resonator (T<sub>A</sub> = -40 to +85°C)

Manufacturer	Product Name	Frequency (MHz)	Recommended Circuit constant		Oscillator Voltage range		Remarks
			C1 (pF)	C2 (pF)	MIN. (V)	MAX. (V)	
Kyocera Corp.	PBRC4.19A	4.19	33	33	2.0	6.0	
	PBRC4.19B	4.19	On chip	On chip	2.0	6.0	Capacitor on chip
	KBR-4.19MSA	4.19	33	33	2.0	6.0	
	KBR-4.19MKS	4.19	On chip	On chip	2.0	6.0	Capacitor on chip
	PBRC4.91A	4.91	33	33	2.0	6.0	
	PBRC4.91B	4.91	On chip	On chip	2.0	6.0	Capacitor on chip
	KBR-4.91MSA	4.91	33	33	2.0	6.0	
	KBR-4.91MKS	4.91	On chip	On chip	2.0	6.0	Capacitor on chip

**Caution** The oscillation circuit constants and oscillation voltage range indicate conditions for stable oscillation. However, they do not guarantee accuracy of the oscillation frequency. If the application circuit requires accuracy of the oscillation frequency, it is necessary to set the oscillation frequency in the application circuit. For this, it is necessary to directly contact the manufacturer of the resonator being used.

Capacitance (T<sub>A</sub> = 25°C, V<sub>DD</sub> = V<sub>SS</sub> = 0 V)

Parameter	Symbol	Test Conditions		MIN.	TYP.	MAX.	Unit
Input capacitance	C <sub>IN</sub>	f = 1 MHz Measured pins returned to 0 V.				15	pF
Input/output capacitance	C <sub>IO</sub>	f = 1 MHz Measured pins returned to 0 V.	P01 to P06, P10 to P17, P20 to P27, P30 to P37, P40 to P47, P50 to P57, P64 to P67, P70 to P72, P120 to P127, P130, P131			15	pF
			P60 to P63			20	pF

**Remark** The characteristics of the dual-function pins are the same as those of the port pins unless otherwise specified.

**Note** For use as P07, use an inverter to input the reverse phase of P07 to the XT2 pin.

DC Characteristics (T<sub>A</sub> = -40 to +85°C, V<sub>DD</sub> = 2.0 to 6.0 V)

Parameter	Symbol	Test Conditions	MIN.	TYP.	MAX.	Unit	
Input voltage, high	V <sub>IH1</sub>	P10 to P17, P21, P23, P30 to P32, P35 to P37, P40 to P47, P50 to P57, P64 to P67, P71, P120 to P127, P130, P131	V <sub>DD</sub> = 2.7 to 6.0 V	0.7 V <sub>DD</sub>		V <sub>DD</sub>	V
				0.8 V <sub>DD</sub>		V <sub>DD</sub>	V
	V <sub>IH2</sub>	P00 to P06, P20, P22, P24 to P27, P33, P34, P70, P72, RESET	V <sub>DD</sub> = 2.7 to 6.0 V	0.8 V <sub>DD</sub>		V <sub>DD</sub>	V
				0.85 V <sub>DD</sub>		V <sub>DD</sub>	V
	V <sub>IH3</sub>	P60 to P63 (N-ch open-drain)	V <sub>DD</sub> = 2.7 to 6.0 V	0.7 V <sub>DD</sub>		15	V
				0.8 V <sub>DD</sub>		15	V
	V <sub>IH4</sub>	X1, X2	V <sub>DD</sub> = 2.7 to 6.0 V	V <sub>DD</sub> - 0.5		V <sub>DD</sub>	V
				V <sub>DD</sub> - 0.2		V <sub>DD</sub>	V
	V <sub>IH5</sub>	XT1/P07, XT2	4.5 V ≤ V <sub>DD</sub> ≤ 6.0 V	0.8 V <sub>DD</sub>		V <sub>DD</sub>	V
			2.7 V ≤ V <sub>DD</sub> < 4.5 V	0.9 V <sub>DD</sub>		V <sub>DD</sub>	V
2.0 V ≤ V <sub>DD</sub> < 2.7 V <sup>Note</sup>			0.9 V <sub>DD</sub>		V <sub>DD</sub>	V	
Input voltage, low	V <sub>IL1</sub>	P10 to P17, P21, P23, P30 to P32, P35 to P37, P40 to P47, P50 to P57, P64 to P67, P71, P120 to P127, P130, P131	V <sub>DD</sub> = 2.7 to 6.0 V	0		0.3 V <sub>DD</sub>	V
				0		0.2 V <sub>DD</sub>	V
	V <sub>IL2</sub>	P00 to P06, P20, P22, P24 to P27, P33, P34, P70, P72, RESET	V <sub>DD</sub> = 2.7 to 6.0 V	0		0.2 V <sub>DD</sub>	V
				0		0.15 V <sub>DD</sub>	V
	V <sub>IL3</sub>	P60 to P63	4.5 V ≤ V <sub>DD</sub> ≤ 6.0 V	0		0.3 V <sub>DD</sub>	V
			2.7 V ≤ V <sub>DD</sub> < 4.5 V	0		0.2 V <sub>DD</sub>	V
				0		0.1 V <sub>DD</sub>	V
	V <sub>IL4</sub>	X1, X2	V <sub>DD</sub> = 2.7 to 6.0 V	0		0.4	V
				0		0.2	V
	V <sub>IL5</sub>	XT1/P07, XT2	4.5 V ≤ V <sub>DD</sub> ≤ 6.0 V	0		0.2 V <sub>DD</sub>	V
2.7 V ≤ V <sub>DD</sub> < 4.5 V			0		0.1 V <sub>DD</sub>	V	
2.0 V ≤ V <sub>DD</sub> < 2.7 V <sup>Note</sup>			0		0.1 V <sub>DD</sub>	V	
Output voltage, high	V <sub>OH</sub>	V <sub>DD</sub> = 4.5 to 6.0 V, I <sub>OH</sub> = -1mA	V <sub>DD</sub> - 1.0			V	
		I <sub>OH</sub> = -100 μA	V <sub>DD</sub> - 0.5			V	
Output voltage, low	V <sub>OL1</sub>	P50 to P57, P60 to P63	V <sub>DD</sub> = 4.5 to 6.0 V, I <sub>OL</sub> = 15 mA		0.4	2.0	V
		P01 to P06, P10 to P17, P20 to P27, P30 to P37, P40 to P47, P64 to P67, P70 to P72, P120 to P127, P130, P131	V <sub>DD</sub> = 4.5 to 6.0 V, I <sub>OL</sub> = 1.6 mA			0.4	V
	V <sub>OL2</sub>	SB0, SB1, SCK0 open-drain, pulled-up (R = 1 KΩ)	V <sub>DD</sub> = 4.5 to 6.0 V,			0.2 V <sub>DD</sub>	V
	V <sub>OL3</sub>	I <sub>OL</sub> = 400 μA				0.5	V

**Note** For using the P07/X1 pins as P07, input the reverse phase of P07 to the XT2 pin.

**Remark** The characteristics of a dual-function pin and a port pin are the same unless specified otherwise.

DC Characteristics (T<sub>A</sub> = -40 to +85°C, V<sub>DD</sub> = 2.7 to 6.0 V)

Parameter	Symbol	Test Conditions		MIN.	TYP.	MAX.	Unit
Input leakage current, high	I <sub>LIH1</sub>	V <sub>IN</sub> = V <sub>DD</sub>	P00 to P06, P10 to P17, P20 to P27, P30 to P37, P40 to P47, P50 to P57, P60 to P67, P70 to P72, P120 to P127, P130, P131, $\overline{\text{RESET}}$			3	μA
	I <sub>LIH2</sub>		X1, X2, XT1/P07, XT2			20	μA
	I <sub>LIH3</sub>	V <sub>IN</sub> = 15 V	P60 to P63			80	μA
Input leakage current, low	I <sub>LIL1</sub>	V <sub>IN</sub> = 0 V	P00 to P06, P10 to P17, P20 to P27, P30 to P37, P40 to P47, P50 to P57, P64 to P67, P70 to P72, P120 to P127, P130, P131, $\overline{\text{RESET}}$			-3	μA
	I <sub>LIL2</sub>		X1, X2, XT1/P07, XT2			-20	μA
	I <sub>LIL3</sub>		P60 to P63			-3 <sup>Note 1</sup>	μA
Output leakage current, high	I <sub>LOH</sub>	V <sub>OUT</sub> = V <sub>DD</sub>				3	μA
Output leakage current, low	I <sub>LOL</sub>	V <sub>OUT</sub> = 0 V				-3	μA
Mask option pull-up resistor	R <sub>1</sub>	V <sub>IN</sub> = 0 V, P60 to P63		20	40	90	kΩ
Software pull-up resistor <sup>Note 2</sup>	R <sub>2</sub>	V <sub>IN</sub> = 0 V, P01 to P06, P10 to P17, P20 to P27, P30 to P37, P40 to P47, P50 to P57, P64 to P67, P70 to P72, P120 to P127, P130, P131	4.5 V ≤ V <sub>DD</sub> ≤ 6.0 V	15	40	90	kΩ
			2.7 V ≤ V <sub>DD</sub> < 4.5 V	20		500	kΩ

**Notes** 1. For P60 to P63 without on-chip pull-up resistor (specifiable by mask option), a low-level input leakage current of -200 μA (MAX.) flows only during the 1.5 clocks (no wait) after an instruction has been executed to read out port 6 (P6) or port mode register 6 (PM6). Outside the period of 1.5 clocks following executing a read-out instruction, the current is -3 μA (MAX.).

2. A software pull-up resistor can be used only in the range of V<sub>DD</sub> = 2.7 to 6.0 V.

**Remark** The characteristics of a dual-function pin and a port pin are the same unless specified otherwise.

DC Characteristics (T<sub>A</sub> = -40 to +85°C, V<sub>DD</sub> = 2.0 to 6.0 V)

Parameter	Symbol	Test Conditions	MIN.	TYP.	MAX.	Unit	
Power supply current <b>Note 5</b>	I <sub>DD1</sub>	5.0 MHz Crystal oscillation operating mode (f <sub>xx</sub> = 2.5 MHz) <b>Note 3</b>	V <sub>DD</sub> = 5.0 V ±10 % <b>Note 1</b>		4	12	mA
			V <sub>DD</sub> = 3.0 V ±10 % <b>Note 2</b>		0.6	1.8	mA
			V <sub>DD</sub> = 2.2 V ±10 % <b>Note 2</b>		0.35	1.05	mA
		5.0 MHz Crystal oscillation operating mode (f <sub>xx</sub> = 5.0 MHz) <b>Note 4</b>	V <sub>DD</sub> = 5.0 V ±10 % <b>Note 1</b>		6.5	19.5	mA
			V <sub>DD</sub> = 3.0 V ±10 % <b>Note 2</b>		0.8	2.4	mA
	I <sub>DD2</sub>	5.0 MHz Crystal oscillation HALT mode (f <sub>xx</sub> = 2.5 MHz) <b>Note 3</b>	V <sub>DD</sub> = 5.0 V ±10 %		1.4	4.2	mA
			V <sub>DD</sub> = 3.0 V ±10 %		0.5	1.5	mA
			V <sub>DD</sub> = 2.2 V ±10 %		280	840	μA
		5.0 MHz Crystal oscillation HALT mode (f <sub>xx</sub> = 5.0 MHz) <b>Note 4</b>	V <sub>DD</sub> = 5.0 V ±10 %		1.6	4.8	mA
			V <sub>DD</sub> = 3.0 V ±10 %		0.65	1.95	mA
	I <sub>DD3</sub>	32.768 kHz Crystal oscillation operating mode <b>Note 6</b>	V <sub>DD</sub> = 5.0 V ±10 %		60	120	μA
			V <sub>DD</sub> = 3.0 V ±10 %		32	64	μA
			V <sub>DD</sub> = 2.2 V ±10 %		24	48	μA
I <sub>DD4</sub>	32.768 kHz Crystal oscillation HALT mode <b>Note 6</b>	V <sub>DD</sub> = 5.0 V ±10 %		25	55	μA	
		V <sub>DD</sub> = 3.0 V ±10 %		5	15	μA	
		V <sub>DD</sub> = 2.2 V ±10 %		2.5	12.5	μA	
I <sub>DD5</sub>	XT1 = V <sub>DD</sub> STOP mode When feedback resistor is used	V <sub>DD</sub> = 5.0 V ±10 %		1	30	μA	
		V <sub>DD</sub> = 3.0 V ±10 %		0.5	10	μA	
		V <sub>DD</sub> = 2.2 V ±10 %		0.3	10	μA	
I <sub>DD6</sub>	XT1 = V <sub>DD</sub> STOP mode When feedback resistor is unused	V <sub>DD</sub> = 5.0 V ±10 %		0.1	30	μA	
		V <sub>DD</sub> = 3.0 V ±10 %		0.05	10	μA	
		V <sub>DD</sub> = 2.2 V ±10 %		0.05	10	μA	

- Notes**
1. Operating in high-speed mode (when set the processor clock control register (PCC) to 00H).
  2. Operating in low-speed mode (when set the PCC to 04H).
  3. Operation with the main system clock f<sub>xx</sub> = f<sub>x</sub>/2 (when oscillation mode selection register (OSMS) is set to 00H)
  4. Operation with the main system clock f<sub>xx</sub> = f<sub>x</sub> (when OSMS is set to 01H)
  5. This current flows in the V<sub>DD</sub> and AV<sub>DD</sub> pins.  
However, a current flowing in the A/D converter, D/A converter, and on-chip pull-up resistor are not included.
  6. When the main system clock operation is halted

AC Characteristics

(1) Basic operation (T<sub>A</sub> = -40 to +85°C, V<sub>DD</sub> = 2.0 to 6.0 V)

Parameter	Symbol	Test Conditions	MIN.	TYP.	MAX.	Unit	
Cycle time (Min. instruction execution time)	T <sub>cy</sub>	Operating on main system clock (f <sub>xx</sub> = 2.5 MHz) <sup>Note 1</sup>	V <sub>DD</sub> = 2.7 to 6.0 V	0.8		64	μs
				2.2		64	μs
		Operating on main system clock (f <sub>xx</sub> = 5.0 MHz) <sup>Note 2</sup>	4.5 V ≤ V <sub>DD</sub> ≤ 6.0 V	0.4		32	μs
			2.7 V ≤ V <sub>DD</sub> < 4.5 V	0.8		32	μs
★		Operating on sub system clock	40 <sup>Note 3</sup>	122	125	μs	
T100, T101, T11, T12 input frequency	f <sub>TI</sub>	V <sub>DD</sub> = 4.5 to 6.0 V	0		4	MHz	
			0		275	kHz	
T100 input high/ low level width	t <sub>TIH</sub> , t <sub>TIL</sub>		8/f <sub>sam</sub> <sup>Note 4</sup>			μs	
T101, T11, T12 input high/ low-level width	t <sub>TIH</sub> , t <sub>TIL</sub>	V <sub>DD</sub> = 4.5 to 6.0 V	100			ns	
			1.8			μs	
Interrupt request input high/low -level width	t <sub>INTH</sub> , t <sub>INTL</sub>	INTP0	8/f <sub>sam</sub> <sup>Note 4</sup>			μs	
		INTP1 to INTP6, KR0 to KR7	V <sub>DD</sub> = 2.7 to 6.0 V	10			μs
				20			μs
RESET low level width	t <sub>RSL</sub>	V <sub>DD</sub> = 2.7 to 6.0 V	10			μs	
			20			μs	

- Notes**
1. Main system clock f<sub>xx</sub> = f<sub>x</sub>/2 operation (when an oscillation mode selection register (OSMS) is set to 00H)
  2. Main system clock f<sub>xx</sub> = f<sub>x</sub> operation (when OSMS is set to 01H)
  3. On an external clock. When a crystal oscillation is used, the minimum value is 114 μs.
  4. In combination with bits 0 (SCS0) and 1 (SCS1) of sampling clock select register (SCS), selection of f<sub>sam</sub> is possible between f<sub>xx</sub>/2<sup>N</sup>, f<sub>xx</sub>/32, f<sub>xx</sub>/64 and f<sub>xx</sub>/128 (when N= 0 to 4).

T<sub>CY</sub> vs V<sub>DD</sub> (At f<sub>xx</sub> = f<sub>x</sub>/2 main system clock operation)

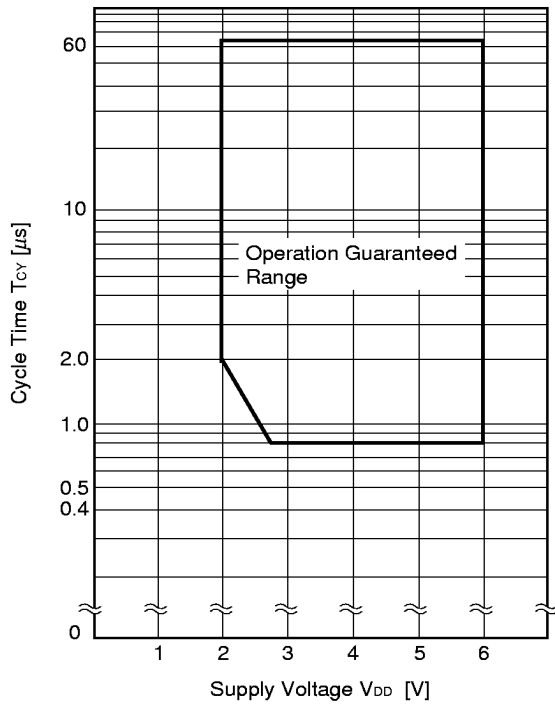

T<sub>CY</sub> vs V<sub>DD</sub> (At f<sub>xx</sub> = f<sub>x</sub> main system clock operation)

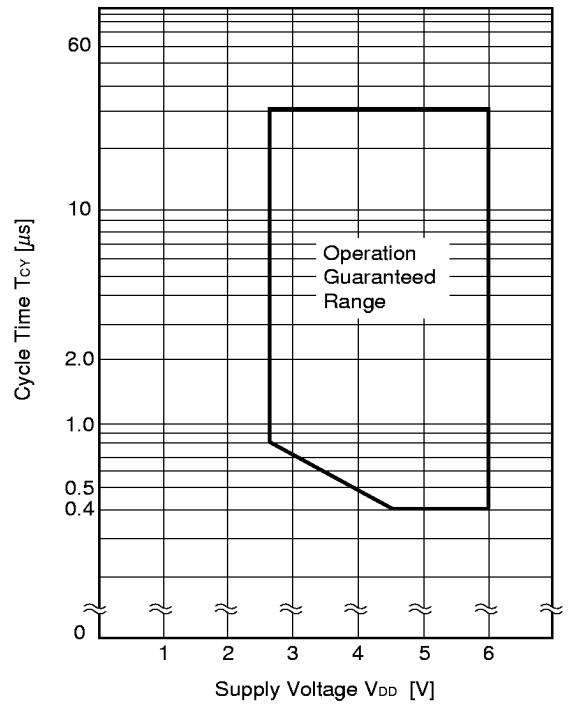

## (2) Read/write operation

(a) When MCS = 1, PCC2 to PCC0 = 000B ( $T_A = -40$  to  $+85^\circ\text{C}$ ,  $V_{DD} = 4.5$  to  $6.0$  V)

Parameter	Symbol	Test Conditions	MIN.	MAX.	Unit
ASTB high-level width	$t_{ASTH}$		$0.85t_{CY} - 50$		ns
Address setup time	$t_{ADS}$		$0.85t_{CY} - 50$		ns
Address hold time	$t_{ADH}$		50		ns
Data input time from address	$t_{ADD1}$			$(2.85 + 2n)t_{CY} - 80$	ns
	$t_{ADD2}$			$(4 + 2n)t_{CY} - 100$	ns
Data input time from $\overline{RD}\downarrow$	$t_{RDD1}$			$(2 + 2n)t_{CY} - 100$	ns
	$t_{RDD2}$			$(2.85 + 2n)t_{CY} - 100$	ns
Read data hold time	$t_{RDH}$		0		ns
$\overline{RD}$ low-level width	$t_{RDL1}$		$(2 + 2n)t_{CY} - 60$		ns
	$t_{RDL2}$		$(2.85 + 2n)t_{CY} - 60$		ns
$\overline{WAIT}\downarrow$ input time from $\overline{RD}\downarrow$	$t_{RDWT1}$			$0.85t_{CY} - 50$	ns
	$t_{RDWT2}$			$2t_{CY} - 60$	ns
$\overline{WAIT}\downarrow$ input time from $\overline{WR}\downarrow$	$t_{WRWT}$			$2t_{CY} - 60$	ns
$\overline{WAIT}$ low-level width	$t_{WTL}$		$(1.15 + 2n)t_{CY}$	$(2 + 2n)t_{CY}$	ns
Write data setup time	$t_{WDS}$		$(2.85 + 2n)t_{CY} - 100$		ns
Write data hold time	$t_{WDH}$		20		ns
$\overline{WR}$ low-level width	$t_{WRL}$		$(2.85 + 2n)t_{CY} - 60$		ns
$\overline{RD}\downarrow$ delay time from $\overline{ASTB}\downarrow$	$t_{ASTRD}$		25		ns
$\overline{WR}\downarrow$ delay time from $\overline{ASTB}\downarrow$	$t_{ASTWR}$		$0.85t_{CY} + 20$		ns
ASTB $\uparrow$ delay time from $\overline{RD}\uparrow$ in external fetch	$t_{RDAST}$		$0.85t_{CY} - 10$	$1.15t_{CY} + 20$	ns
Address hold time from $\overline{RD}\uparrow$ in external fetch	$t_{RDADH}$		$0.85t_{CY} - 50$	$1.15t_{CY} + 50$	ns
Write data output time from $\overline{RD}\uparrow$	$t_{RDWD}$		40		ns
Write data output time from $\overline{WR}\downarrow$	$t_{WRWD}$		0	50	ns
Address hold time from $\overline{WR}\uparrow$	$t_{WRADH}$		$0.85t_{CY}$	$1.15t_{CY} + 40$	ns
$\overline{RD}\uparrow$ delay time from $\overline{WAIT}\uparrow$	$t_{WTRD}$		$1.15t_{CY} + 40$	$3.15t_{CY} + 40$	ns
$\overline{WR}\uparrow$ delay time from $\overline{WAIT}\uparrow$	$t_{WTWR}$		$1.15t_{CY} + 30$	$3.15t_{CY} + 30$	ns

- Remarks**
1. MCS: Oscillation mode selection register (OSMS) bit 0
  2. PCC2 to PCC0: Processor clock control register (PCC) bits 2 to 0
  3.  $t_{CY} = T_{CY}/4$
  4. n indicates number of waits.



(b) When except MCS = 1, PCC2 to PCC0 = 000B (T<sub>A</sub> = -40 to +85°C, V<sub>DD</sub> = 2.0 to 6.0 V)

Parameter	Symbol	Test Conditions	MIN.	MAX.	Unit
ASTB high-level width	t <sub>ASTH</sub>	V <sub>DD</sub> = 2.7 to 6.0 V	t <sub>cy</sub> - 80		ns
			t <sub>cy</sub> - 150		ns
Address setup time	t <sub>ADS</sub>	V <sub>DD</sub> = 2.7 to 6.0 V	t <sub>cy</sub> - 80		ns
			t <sub>cy</sub> - 150		ns
Address hold time	t <sub>ADH</sub>	V <sub>DD</sub> = 2.7 to 6.0 V	0.4t <sub>cy</sub> - 10		ns
			0.37t <sub>cy</sub> - 40		ns
Data input time from address	t <sub>ADD1</sub>	V <sub>DD</sub> = 2.7 to 6.0 V		(3 + 2n)t <sub>cy</sub> - 160	ns
				(3 + 2n)t <sub>cy</sub> - 320	ns
	t <sub>ADD2</sub>	V <sub>DD</sub> = 2.7 to 6.0 V		(4 + 2n)t <sub>cy</sub> - 200	ns
				(4 + 2n)t <sub>cy</sub> - 300	ns
Data input time from $\overline{RD}\downarrow$	t <sub>RDD1</sub>	V <sub>DD</sub> = 2.7 to 6.0 V		(1.4 + 2n)t <sub>cy</sub> - 70	ns
				(1.37 + 2n)t <sub>cy</sub> - 120	ns
	t <sub>RDD2</sub>	V <sub>DD</sub> = 2.7 to 6.0 V		(2.4 + 2n)t <sub>cy</sub> - 70	ns
				(2.37 + 2n)t <sub>cy</sub> - 120	ns
Read data hold time	t <sub>RDH</sub>		0		ns
$\overline{RD}$ low-level width	t <sub>RDL1</sub>	V <sub>DD</sub> = 2.7 to 6.0 V	(1.4 + 2n)t <sub>cy</sub> - 20		ns
			(1.37 + 2n)t <sub>cy</sub> - 20		ns
	t <sub>RDL2</sub>	V <sub>DD</sub> = 2.7 to 6.0 V	(2.4 + 2n)t <sub>cy</sub> - 20		ns
			(2.37 + 2n)t <sub>cy</sub> - 20		ns
$\overline{WAIT}\downarrow$ input time from $\overline{RD}\downarrow$	t <sub>RDWT1</sub>	V <sub>DD</sub> = 2.7 to 6.0 V		t <sub>cy</sub> - 100	ns
				t <sub>cy</sub> - 200	ns
	t <sub>RDWT2</sub>	V <sub>DD</sub> = 2.7 to 6.0 V		2t <sub>cy</sub> - 100	ns
				2t <sub>cy</sub> - 200	ns
$\overline{WAIT}\downarrow$ input time from $\overline{WR}\downarrow$	t <sub>WRWT</sub>	V <sub>DD</sub> = 2.7 to 6.0 V		2t <sub>cy</sub> - 100	ns
				2t <sub>cy</sub> - 200	ns
$\overline{WAIT}$ low-level width	t <sub>WTL</sub>		(1 + 2n)t <sub>cy</sub>	(2 + 2n)t <sub>cy</sub>	ns
Write data setup time	t <sub>WDS</sub>	V <sub>DD</sub> = 2.7 to 6.0 V	(2.4 + 2n)t <sub>cy</sub> - 60		ns
			(2.37 + 2n)t <sub>cy</sub> - 100		ns
Write data hold time	t <sub>WDH</sub>		20		ns
$\overline{WR}$ low-level width	t <sub>WRL</sub>	V <sub>DD</sub> = 2.7 to 6.0 V	(2.4 + 2n)t <sub>cy</sub> - 20		ns
			(2.37 + 2n)t <sub>cy</sub> - 20		ns
$\overline{RD}\downarrow$ delay time from $\overline{ASTB}\downarrow$	t <sub>ASTRD</sub>	V <sub>DD</sub> = 2.7 to 6.0 V	0.4t <sub>cy</sub> - 30		ns
			0.37t <sub>cy</sub> - 50		ns
$\overline{WR}\downarrow$ delay time from $\overline{ASTB}\downarrow$	t <sub>ASTWR</sub>	V <sub>DD</sub> = 2.7 to 6.0 V	1.4t <sub>cy</sub> - 30		ns
			1.37t <sub>cy</sub> - 50		ns

- Remarks**
1. MCS: Oscillation mode selection register (OSMS) bit 0
  2. PCC2 to PCC0: Processor clock control register (PCC) bits 2 to 0
  3. t<sub>cy</sub> = T<sub>cy</sub>/4
  4. n indicates number of waits.

(b) When except MCS = 1, PCC2 to PCC0 = 000B ( $T_A = -40$  to  $+85^\circ\text{C}$ ,  $V_{DD} = 2.0$  to  $6.0$  V)

Parameter	Symbol	Test Conditions	MIN.	MAX.	Unit
ASTB $\uparrow$ delay time from $\overline{\text{RD}}\uparrow$ in external fetch	t <sub>RDAST</sub>		$t_{CY} - 10$	$t_{CY} + 20$	ns
Address hold time from $\overline{\text{RD}}\uparrow$ in external fetch	t <sub>RDADH</sub>		$t_{CY} - 50$	$t_{CY} + 50$	ns
Write data output time from $\overline{\text{RD}}\uparrow$	t <sub>RDWD</sub>	$V_{DD} = 2.7$ to $6.0$ V	$0.4t_{CY} - 20$		ns
			$0.37t_{CY} - 40$		ns
Write data output time from $\overline{\text{WR}}\downarrow$	t <sub>WRWD</sub>	$V_{DD} = 2.7$ to $6.0$ V	0	60	ns
			0	120	ns
Address hold time from $\overline{\text{WR}}\uparrow$	t <sub>WRADH</sub>	$V_{DD} = 2.7$ to $6.0$ V	$t_{CY}$	$t_{CY} + 60$	ns
			$t_{CY}$	$t_{CY} + 120$	ns
$\overline{\text{RD}}\uparrow$ delay time from $\overline{\text{WAIT}}\uparrow$	t <sub>WTRD</sub>	$V_{DD} = 2.7$ to $6.0$ V	$0.6t_{CY} + 180$	$2.6t_{CY} + 180$	ns
			$0.63t_{CY} + 350$	$2.63t_{CY} + 350$	ns
$\overline{\text{WR}}\uparrow$ delay time from $\overline{\text{WAIT}}\uparrow$	t <sub>WTWR</sub>	$V_{DD} = 2.7$ to $6.0$ V	$0.6t_{CY} + 120$	$2.6t_{CY} + 120$	ns
			$0.63t_{CY} + 240$	$2.63t_{CY} + 240$	ns

- Remarks**
1. MCS: Oscillation mode selection register (OSMS) bit 0
  2. PCC2 to PCC0: Processor clock control register (PCC) bits 2 to 0
  3.  $t_{CY} = T_{CY}/4$
  4. n indicates number of waits.

(3) Serial interface (T<sub>A</sub> = -40 to +85°C, V<sub>DD</sub> = 2.0 to 6.0 V)

(a) Serial interface channel 0

(i) 3-wire serial I/O mode ( $\overline{\text{SCK0}}$ ... Internal clock output)

Parameter	Symbol	Test Conditions	MIN.	TYP.	MAX.	Unit
$\overline{\text{SCK0}}$ cycle time	t <sub>KCY1</sub>	4.5 V ≤ V <sub>DD</sub> ≤ 6.0 V	800			ns
		2.7 V ≤ V <sub>DD</sub> < 4.5 V	1600			ns
			3200			ns
$\overline{\text{SCK0}}$ high/low-level width	t <sub>KH1</sub> , t <sub>KL1</sub>	V <sub>DD</sub> = 4.5 to 6.0 V	t <sub>KCY1</sub> /2 - 50			ns
			t <sub>KCY1</sub> /2 - 100			ns
SI0 setup time (to $\overline{\text{SCK0}}$ ↑)	t <sub>SIK1</sub>	4.5 V ≤ V <sub>DD</sub> ≤ 6.0 V	100			ns
		2.7 V ≤ V <sub>DD</sub> < 4.5 V	150			ns
			300			ns
SI0 hold time (from $\overline{\text{SCK0}}$ ↑)	t <sub>KS1</sub>		400			ns
SO0 output delay time from $\overline{\text{SCK0}}$ ↓	t <sub>KSO1</sub>	C = 100 pF <b>Note</b>			300	ns

**Note** C is the load capacitance of SO0 output line.

(ii) 3-wire serial I/O mode ( $\overline{\text{SCK0}}$ ... External clock input)

Parameter	Symbol	Test Conditions	MIN.	TYP.	MAX.	Unit
$\overline{\text{SCK0}}$ cycle time	t <sub>KCY2</sub>	4.5 V ≤ V <sub>DD</sub> ≤ 6.0 V	800			ns
		2.7 V ≤ V <sub>DD</sub> < 4.5 V	1600			ns
			3200			ns
$\overline{\text{SCK0}}$ high/low-level width	t <sub>KH2</sub> , t <sub>KL2</sub>	4.5 V ≤ V <sub>DD</sub> ≤ 6.0 V	400			ns
		2.7 V ≤ V <sub>DD</sub> < 4.5 V	800			ns
			1600			ns
SI0 setup time (to $\overline{\text{SCK0}}$ ↑)	t <sub>SIK2</sub>		100			ns
SI0 hold time (from $\overline{\text{SCK0}}$ ↑)	t <sub>KS2</sub>		400			ns
SO0 output delay time from $\overline{\text{SCK0}}$ ↓	t <sub>KSO2</sub>	C = 100 pF <b>Note</b>			300	ns
$\overline{\text{SCK0}}$ rise, fall time	t <sub>R2</sub> , t <sub>F2</sub>	When using external device expansion function			160	ns
		When not using external device expansion function			1000	ns

**Note** C is the load capacitance of SO0 output line.

(iii) SBI mode ( $\overline{\text{SCK0}}$ ... Internal clock output)

Parameter	Symbol	Test Conditions	MIN.	TYP.	MAX.	Unit
$\overline{\text{SCK0}}$ cycle time	$t_{\text{KCY3}}$	$V_{\text{DD}} = 4.5 \text{ to } 6.0 \text{ V}$	800			ns
			3200			ns
$\overline{\text{SCK0}}$ high/low-level width	$t_{\text{KH3}}, t_{\text{KL3}}$	$V_{\text{DD}} = 4.5 \text{ to } 6.0 \text{ V}$	$t_{\text{KCY3}}/2 - 50$			ns
			$t_{\text{KCY3}}/2 - 150$			ns
SB0, SB1 setup time (to $\overline{\text{SCK0}}\uparrow$ )	$t_{\text{SIK3}}$	$V_{\text{DD}} = 4.5 \text{ to } 6.0 \text{ V}$	100			ns
			300			ns
SB0, SB1 hold time (from $\overline{\text{SCK0}}\uparrow$ )	$t_{\text{KSI3}}$		$t_{\text{KCY3}}/2$			ns
SB0, SB1 output delay time from $\overline{\text{SCK0}}\downarrow$	$t_{\text{KSO3}}$	R = 1 kΩ , C = 100 pF <b>Note</b>	$V_{\text{DD}} = 4.5 \text{ to } 6.0 \text{ V}$	0	250	ns
				0	1000	ns
SB0, SB1 $\downarrow$ from $\overline{\text{SCK0}}\uparrow$	$t_{\text{KSB}}$		$t_{\text{KCY3}}$			ns
$\overline{\text{SCK0}}\downarrow$ from SB0, SB1 $\downarrow$	$t_{\text{SBK}}$		$t_{\text{KCY3}}$			ns
SB0, SB1 high-level width	$t_{\text{SBH}}$		$t_{\text{KCY3}}$			ns
SB0, SB1 low-level width	$t_{\text{SBL}}$		$t_{\text{KCY3}}$			ns

**Note** R and C are the load resistors and load capacitance of the  $\overline{\text{SCK0}}$ , SB0 and SB1 output line.

(iv) SBI mode ( $\overline{\text{SCK0}}$ ... External clock input)

Parameter	Symbol	Test Conditions	MIN.	TYP.	MAX.	Unit
$\overline{\text{SCK0}}$ cycle time	$t_{\text{KCY4}}$	$V_{\text{DD}} = 4.5 \text{ to } 6.0 \text{ V}$	800			ns
			3200			ns
$\overline{\text{SCK0}}$ high/low-level width	$t_{\text{KH4}}, t_{\text{KL4}}$	$V_{\text{DD}} = 4.5 \text{ to } 6.0 \text{ V}$	400			ns
			1600			ns
SB0, SB1 setup time (to $\overline{\text{SCK0}}\uparrow$ )	$t_{\text{SIK4}}$	$V_{\text{DD}} = 4.5 \text{ to } 6.0 \text{ V}$	100			ns
			300			ns
SB0, SB1 hold time (from $\overline{\text{SCK0}}\uparrow$ )	$t_{\text{KSI4}}$		$t_{\text{KCY4}}/2$			ns
SB0, SB1 output delay time from $\overline{\text{SCK0}}\downarrow$	$t_{\text{KSO4}}$	R = 1 kΩ , C = 100 pF <b>Note</b>	$V_{\text{DD}} = 4.5 \text{ to } 6.0 \text{ V}$	0	300	ns
				0	1000	ns
SB0, SB1 $\downarrow$ from $\overline{\text{SCK0}}\uparrow$	$t_{\text{KSB}}$		$t_{\text{KCY4}}$			ns
$\overline{\text{SCK0}}\downarrow$ from SB0, SB1 $\downarrow$	$t_{\text{SBK}}$		$t_{\text{KCY4}}$			ns
SB0, SB1 high-level width	$t_{\text{SBH}}$		$t_{\text{KCY4}}$			ns
SB0, SB1 low-level width	$t_{\text{SBL}}$		$t_{\text{KCY4}}$			ns
$\overline{\text{SCK0}}$ rise, fall time	$t_{\text{R4}}, t_{\text{F4}}$	When using external device expansion function			160	ns
		When not using external device expansion function			1000	ns

**Note** R and C are the load resistors and load capacitance of the SB0 and SB1 output line.

(v) 2-wire serial I/O mode ( $\overline{\text{SCK0}}$ ... Internal clock output)

Parameter	Symbol	Test Conditions	MIN.	TYP.	MAX.	Unit
$\overline{\text{SCK0}}$ cycle time	$t_{\text{KCY5}}$	R = 1 kΩ, C = 100 pF <b>Note</b>	$V_{\text{DD}} = 2.7 \text{ to } 6.0 \text{ V}$	1600		ns
				3200		ns
$\overline{\text{SCK0}}$ high-level width	$t_{\text{KH5}}$		$V_{\text{DD}} = 2.7 \text{ to } 6.0 \text{ V}$	$t_{\text{KCY5}}/2 - 160$		ns
				$t_{\text{KCY5}}/2 - 190$		ns
$\overline{\text{SCK0}}$ low-level width	$t_{\text{KL5}}$		$V_{\text{DD}} = 4.5 \text{ to } 6.0 \text{ V}$	$t_{\text{KCY5}}/2 - 50$		ns
				$t_{\text{KCY5}}/2 - 100$		ns
SB0, SB1 setup time (to $\overline{\text{SCK0}}\uparrow$ )	$t_{\text{SIK5}}$		$4.5 \text{ V} \leq V_{\text{DD}} \leq 6.0 \text{ V}$	300		ns
			$2.7 \text{ V} \leq V_{\text{DD}} < 4.5 \text{ V}$	350		ns
				400		ns
SB0, SB1 hold time (from $\overline{\text{SCK0}}\uparrow$ )	$t_{\text{KS15}}$		600		ns	
SB0, SB1 output delay time from $\overline{\text{SCK0}}\downarrow$	$t_{\text{KS05}}$		0		300	ns

**Note** R and C are the load resistors and load capacitance of the  $\overline{\text{SCK0}}$ , SB0 and SB1 output line.

(vi) 2-wire serial I/O mode ( $\overline{\text{SCK0}}$ ... Internal clock input)

Parameter	Symbol	Test Conditions	MIN.	TYP.	MAX.	Unit
$\overline{\text{SCK0}}$ cycle time	$t_{\text{KCY6}}$	$V_{\text{DD}} = 2.7 \text{ to } 6.0 \text{ V}$	1600			ns
			3200			ns
$\overline{\text{SCK0}}$ high-level width	$t_{\text{KH6}}$	$V_{\text{DD}} = 2.7 \text{ to } 6.0 \text{ V}$	650			ns
			1300			ns
$\overline{\text{SCK0}}$ low-level width	$t_{\text{KL6}}$	$V_{\text{DD}} = 2.7 \text{ to } 6.0 \text{ V}$	800			ns
			1600			ns
SB0, SB1 setup time (to $\overline{\text{SCK0}}\uparrow$ )	$t_{\text{SIK6}}$		100		ns	
SB0, SB1 hold time (from $\overline{\text{SCK0}}\uparrow$ )	$t_{\text{KS16}}$		$t_{\text{KCY6}}/2$		ns	
SB0, SB1 output delay time from $\overline{\text{SCK0}}\downarrow$	$t_{\text{KS06}}$	R = 1 kΩ, C = 100 pF <b>Note</b>	$V_{\text{DD}} = 4.5 \text{ to } 6.0 \text{ V}$	0	300	ns
				0	500	ns
$\overline{\text{SCK0}}$ rise, fall time	$t_{\text{R6}}, t_{\text{F6}}$	When using external device expansion function			160	ns
		When not using external device expansion function			1000	ns

**Note** R and C are the load resistors and load capacitance of the  $\overline{\text{SCK0}}$ , SB0 and SB1 output line.

(b) Serial interface channel 1

(i) 3-wire serial I/O mode ( $\overline{\text{SCK1}}$ ...Internal clock output)

Parameter	Symbol	Test Conditions	MIN.	TYP.	MAX.	Unit
$\overline{\text{SCK1}}$ cycle time	$t_{\text{KCY7}}$	$4.5 \text{ V} \leq V_{\text{DD}} \leq 6.0 \text{ V}$	800			ns
		$2.7 \text{ V} \leq V_{\text{DD}} < 4.5 \text{ V}$	1600			ns
			3200			ns
$\overline{\text{SCK1}}$ high/low-level width	$t_{\text{KH7}},$	$V_{\text{DD}} = 4.5 \text{ to } 6.0 \text{ V}$	$t_{\text{KCY7}}/2 - 50$			ns
	$t_{\text{KL7}}$		$t_{\text{KCY7}}/2 - 100$			ns
SI1 setup time (to $\overline{\text{SCK1}}\uparrow$ )	$t_{\text{SIK7}}$	$4.5 \text{ V} \leq V_{\text{DD}} \leq 6.0 \text{ V}$	100			ns
		$2.7 \text{ V} \leq V_{\text{DD}} < 4.5 \text{ V}$	150			ns
			300			ns
SI1 hold time (from $\overline{\text{SCK1}}\uparrow$ )	$t_{\text{KSI7}}$		400			ns
SO1 output delay time from $\overline{\text{SCK1}}\downarrow$	$t_{\text{KSO7}}$	$C = 100 \text{ pF}$ Note			300	ns

**Note** C is the load capacitance of the SO1 output line.

(ii) 3-wire serial I/O mode ( $\overline{\text{SCK1}}$ ...External clock input)

Parameter	Symbol	Test Conditions	MIN.	TYP.	MAX.	Unit	
$\overline{\text{SCK1}}$ cycle time	$t_{\text{KCY8}}$	$4.5 \text{ V} \leq V_{\text{DD}} \leq 6.0 \text{ V}$	800			ns	
		$2.7 \text{ V} \leq V_{\text{DD}} < 4.5 \text{ V}$	1600			ns	
			3200			ns	
$\overline{\text{SCK1}}$ high/low-level width	$t_{\text{KH8}},$	$4.5 \text{ V} \leq V_{\text{DD}} \leq 6.0 \text{ V}$	400			ns	
			$t_{\text{KL8}}$	$2.7 \text{ V} \leq V_{\text{DD}} < 4.5 \text{ V}$	800		ns
					1600		ns
SI1 setup time (to $\overline{\text{SCK1}}\uparrow$ )	$t_{\text{SIK8}}$		100			ns	
SI1 hold time (from $\overline{\text{SCK1}}\uparrow$ )	$t_{\text{KIS8}}$		400			ns	
SO1 output delay time from $\overline{\text{SCK1}}\downarrow$	$t_{\text{KSO8}}$	$C = 100 \text{ pF}$ Note			300	ns	
$\overline{\text{SCK1}}$ rise, fall time	$t_{\text{R8}}, t_{\text{F8}}$	When using external device expansion function			160	ns	
		When not using external device expansion function			1000	ns	

**Note** C is the load capacitance of the SO output line.

(iii) 3-wire serial I/O mode with automatic transmit/receive function ( $\overline{\text{SCK1}}$ ...Internal clock output)

Parameter	Symbol	Test Conditions	MIN.	TYP.	MAX.	Unit
$\overline{\text{SCK1}}$ cycle time	$t_{\text{KCY9}}$	$4.5 \text{ V} \leq V_{\text{DD}} \leq 6.0 \text{ V}$	800			ns
		$2.7 \text{ V} \leq V_{\text{DD}} < 4.5 \text{ V}$	1600			ns
			3200			ns
$\overline{\text{SCK1}}$ high/low-level width	$t_{\text{KH9}}, t_{\text{KL9}}$	$V_{\text{DD}} = 4.5 \text{ to } 6.0 \text{ V}$	$t_{\text{KCY9}}/2 - 50$			ns
			$t_{\text{KCY9}}/2 - 100$			ns
SI1 setup time (to $\overline{\text{SCK1}}\uparrow$ )	$t_{\text{SIK9}}$	$4.5 \text{ V} \leq V_{\text{DD}} \leq 6.0 \text{ V}$	100			ns
		$2.7 \text{ V} \leq V_{\text{DD}} < 4.5 \text{ V}$	150			ns
			300			ns
SI1 hold time (from $\overline{\text{SCK1}}\uparrow$ )	$t_{\text{KSI9}}$		400			ns
SO1 output delay time from $\overline{\text{SCK1}}\downarrow$	$t_{\text{KSO9}}$	$C = 100 \text{ pF}$ Note			300	ns
$\text{STB}\uparrow$ from $\overline{\text{SCK1}}\uparrow$	$t_{\text{SBD}}$		$t_{\text{KCY9}}/2 - 100$		$t_{\text{KCY9}}/2 + 100$	ns
Strobe signal high-level width	$t_{\text{SBW}}$	$V_{\text{DD}} = 2.7 \text{ to } 6.0 \text{ V}$	$t_{\text{KCY9}} - 30$		$t_{\text{KCY9}} + 30$	ns
			$t_{\text{KCY9}} - 60$		$t_{\text{KCY9}} + 60$	ns
Busy signal setup time (to busy signal detection timing)	$t_{\text{BYS}}$		100			ns
Busy signal hold time (from busy signal detection timing)	$t_{\text{BYH}}$	$4.5 \text{ V} \leq V_{\text{DD}} \leq 6.0 \text{ V}$	100			ns
		$2.7 \text{ V} \leq V_{\text{DD}} < 4.5 \text{ V}$	150			ns
			200			ns
$\overline{\text{SCK1}}\downarrow$ from busy inactive	$t_{\text{SPS}}$				$2t_{\text{KCY9}}$	ns

Note C is the load capacitance of the SO1 output line.

(iv) 3-wire serial I/O mode with automatic transmit/receive function ( $\overline{\text{SCK1}}$ ...External clock input)

Parameter	Symbol	Test Conditions	MIN.	TYP.	MAX.	Unit
$\overline{\text{SCK1}}$ cycle time	$t_{\text{KCY10}}$	$4.5 \text{ V} \leq V_{\text{DD}} \leq 6.0 \text{ V}$	800			ns
		$2.7 \text{ V} \leq V_{\text{DD}} < 4.5 \text{ V}$	1600			ns
			3200			ns
$\overline{\text{SCK1}}$ high/low-level width	$t_{\text{KH10}}, t_{\text{KL10}}$	$4.5 \text{ V} \leq V_{\text{DD}} \leq 6.0 \text{ V}$	400			ns
		$2.7 \text{ V} \leq V_{\text{DD}} < 4.5 \text{ V}$	800			ns
			1600			ns
SI1 setup time (to $\overline{\text{SCK1}}\uparrow$ )	$t_{\text{SIK10}}$		100			ns
SI1 hold time (from $\overline{\text{SCK1}}\uparrow$ )	$t_{\text{KIS10}}$		400			ns
SO1 output delay time from $\overline{\text{SCK1}}\downarrow$	$t_{\text{KSO10}}$	$C = 100 \text{ pF}$ Note			300	ns
$\overline{\text{SCK1}}$ rise, fall time	$t_{\text{R10}}, t_{\text{F10}}$	When using external device expansion function			160	ns
		When not using external device expansion function			1000	ns

Note C is the load capacitance of the SO1 output line.

★ (c) Serial interface channel 2

(i) 3-wire serial I/O mode ( $\overline{\text{SCK2}}$ ...Internal clock output)

Parameter	Symbol	Test Conditions	MIN.	TYP.	MAX.	Unit
$\overline{\text{SCK2}}$ cycle time	$t_{\text{KCY11}}$	$4.5 \text{ V} \leq V_{\text{DD}} \leq 6.0 \text{ V}$	800			ns
		$2.7 \text{ V} \leq V_{\text{DD}} < 4.5 \text{ V}$	1600			ns
			3200			ns
$\overline{\text{SCK2}}$ high-/low-level width	$t_{\text{KH11}}$ ,	$V_{\text{DD}} = 4.5 \text{ to } 6.0 \text{ V}$	$t_{\text{KCY7}}/2 - 50$			ns
	$t_{\text{KL11}}$		$t_{\text{KCY7}}/2 - 100$			ns
SI2 setup time (to $\overline{\text{SCK2}}\uparrow$ )	$t_{\text{SIK11}}$	$4.5 \text{ V} \leq V_{\text{DD}} \leq 6.0 \text{ V}$	100			ns
		$2.7 \text{ V} \leq V_{\text{DD}} < 4.5 \text{ V}$	150			ns
			300			ns
SI2 hold time (from $\overline{\text{SCK2}}\uparrow$ )	$t_{\text{KSI11}}$		400			ns
SO2 output delay time from $\overline{\text{SCK2}}\downarrow$	$t_{\text{KSO11}}$	$C = 100 \text{ pF}$ <b>Note</b>			300	ns

**Note** C is the load capacitance of the SO2 output line.

(ii) UART mode (Dedicated baud rate generator output)

Parameter	Symbol	Test Conditions	MIN.	TYP.	MAX.	Unit
Transfer rate		$4.5 \text{ V} \leq V_{\text{DD}} \leq 6.0 \text{ V}$			78125	bps
		$2.7 \text{ V} \leq V_{\text{DD}} < 4.5 \text{ V}$			39063	bps
					19531	bps

(iii) UART mode (External clock input)

Parameter	Symbol	Test Conditions	MIN.	TYP.	MAX.	Unit
ASCK cycle time	$t_{\text{KCY12}}$	$4.5 \text{ V} \leq V_{\text{DD}} \leq 6.0 \text{ V}$	800			ns
		$2.7 \text{ V} \leq V_{\text{DD}} < 4.5 \text{ V}$	1600			ns
			3200			ns
ASCK high-/low-level width	$t_{\text{KH12}}$ ,	$4.5 \text{ V} \leq V_{\text{DD}} \leq 6.0 \text{ V}$	400			ns
	$t_{\text{KL12}}$	$2.7 \text{ V} \leq V_{\text{DD}} < 4.5 \text{ V}$	800			ns
			1600			ns
Transfer rate		$4.5 \text{ V} \leq V_{\text{DD}} \leq 6.0 \text{ V}$			39063	bps
		$2.7 \text{ V} \leq V_{\text{DD}} < 4.5 \text{ V}$			19531	bps
					9766	bps
ASCK rise, fall time	$t_{\text{R12}}$ ,	$V_{\text{DD}} = 4.5 \text{ to } 6.0 \text{ V}$ , when not using external device expansion function.			1000	ns
	$t_{\text{F12}}$				160	ns



AC Timing Test Point (Excluding X1, XT1 Input)

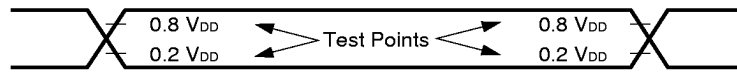

Clock Timing

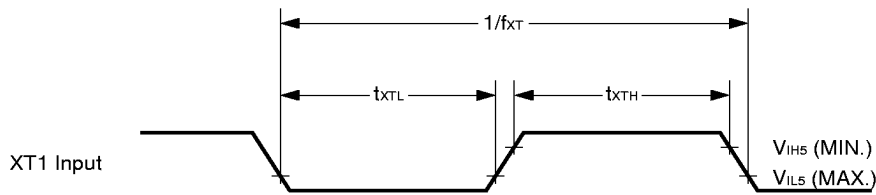
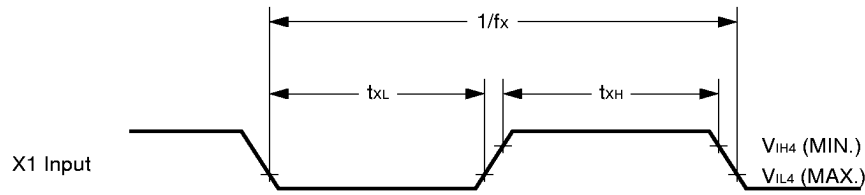

TI Timing

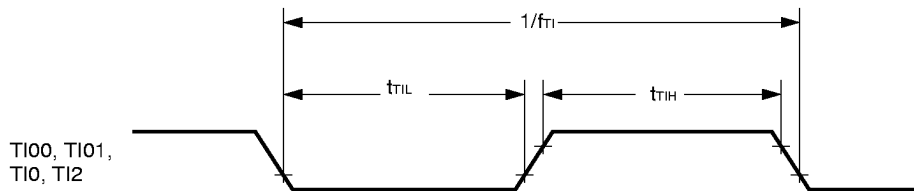

Read/Write Operation

External fetch (no wait) :

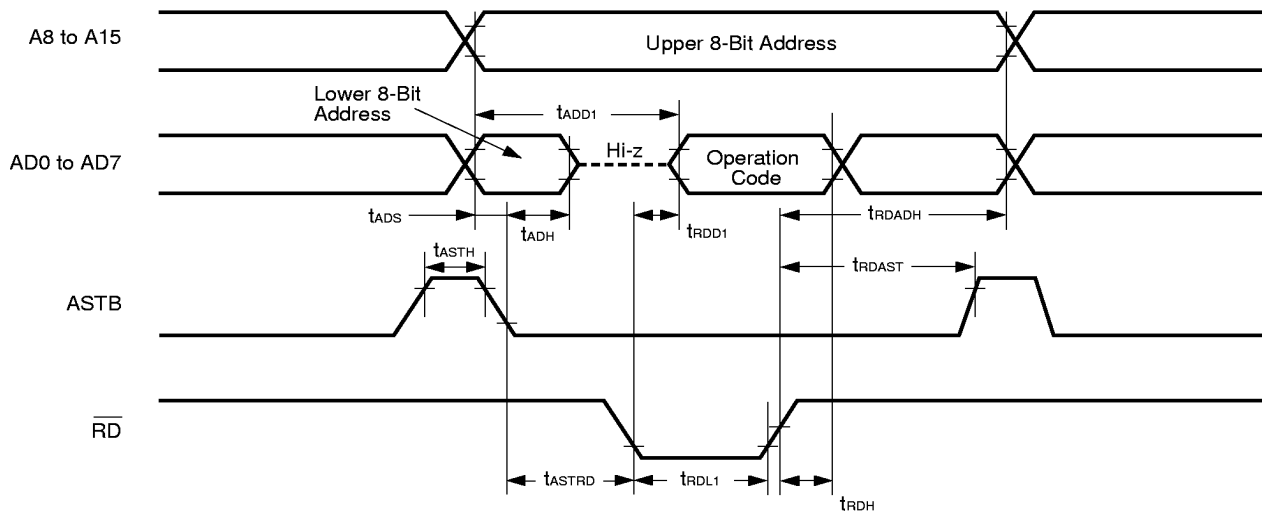

External fetch (wait insertion) :

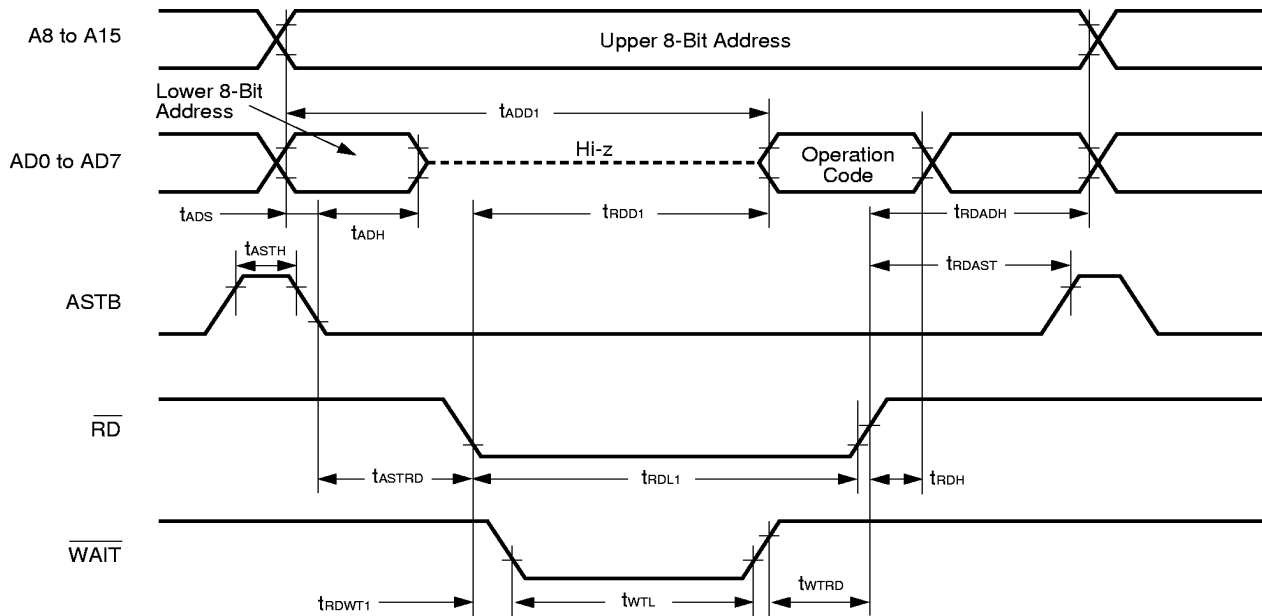

External data access (no wait) :

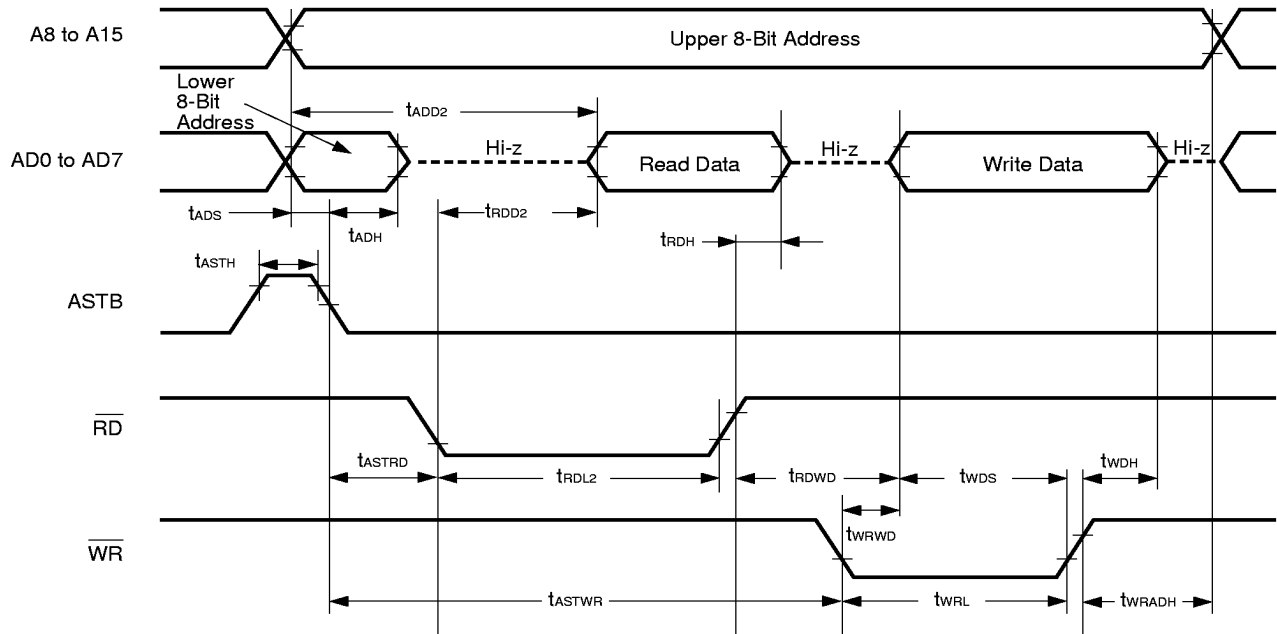

External data access (wait insertion) :

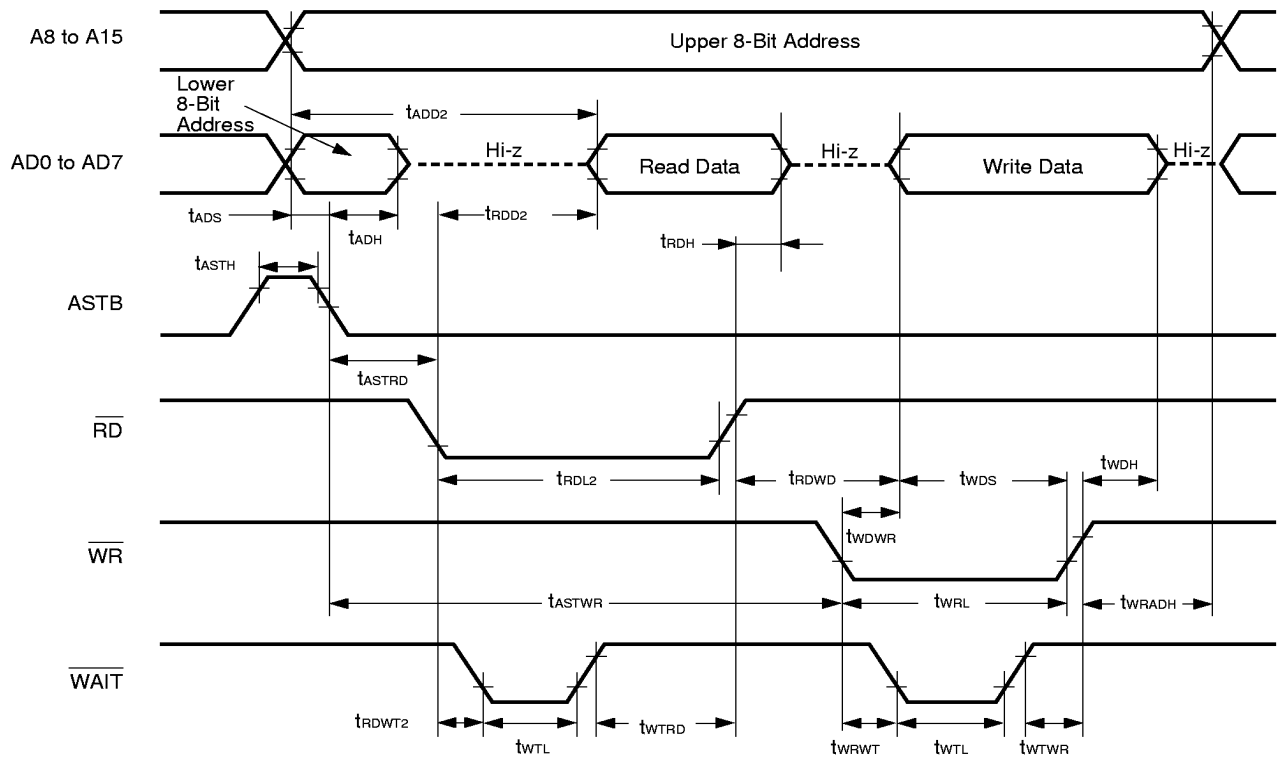

Serial Transfer Timing

3-wire serial I/O mode :

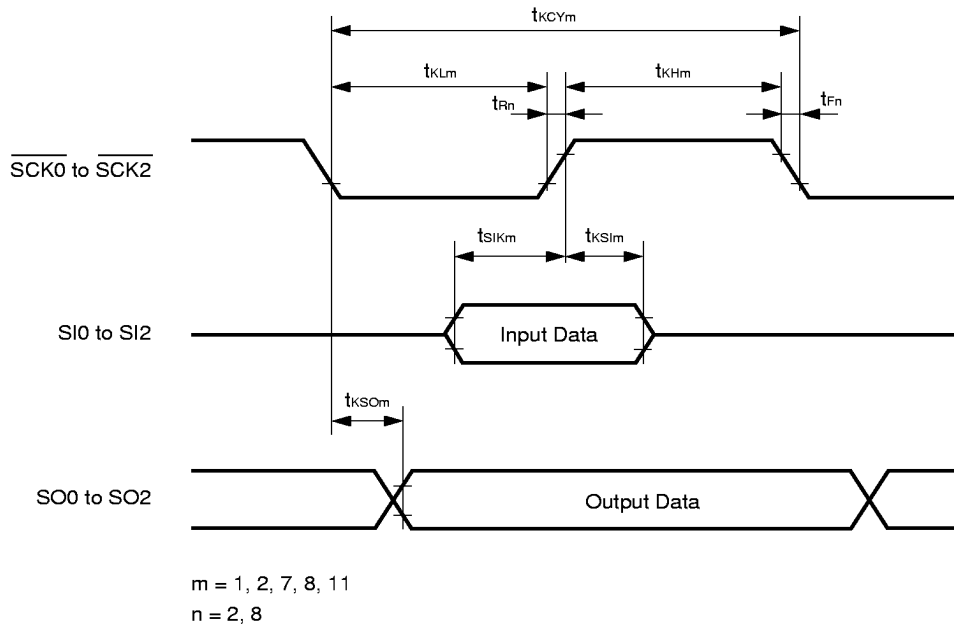

SBI mode (bus release signal transfer) :

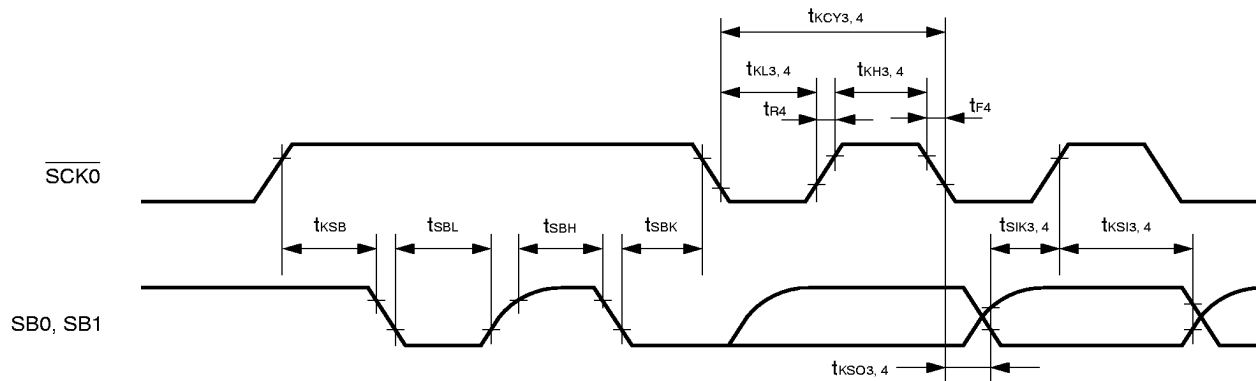

SBI mode (command signal transfer) :

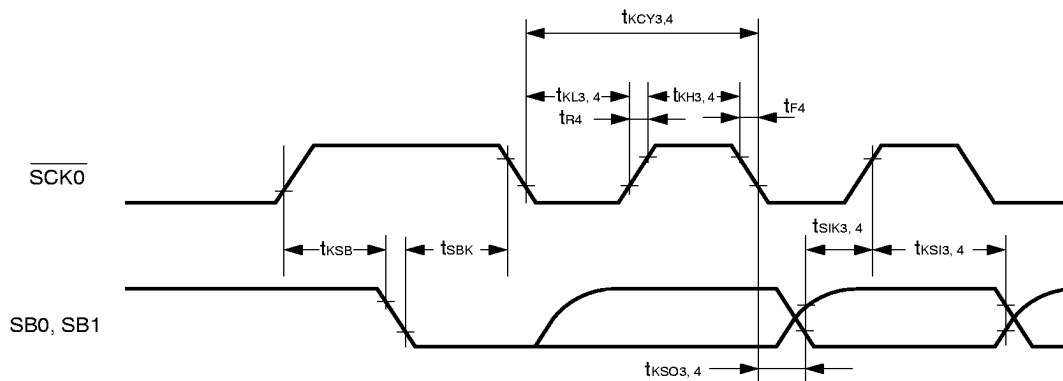

2-wire serial I/O mode :

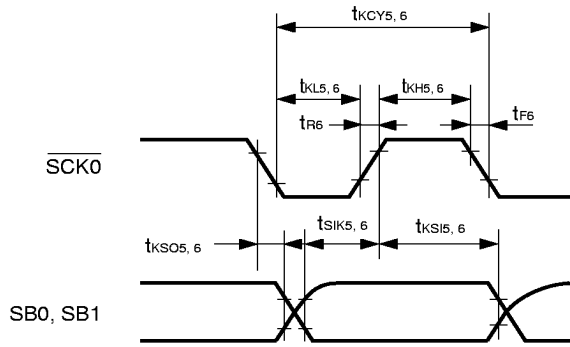

3-wire serial I/O mode with automatic transmit/receive function :

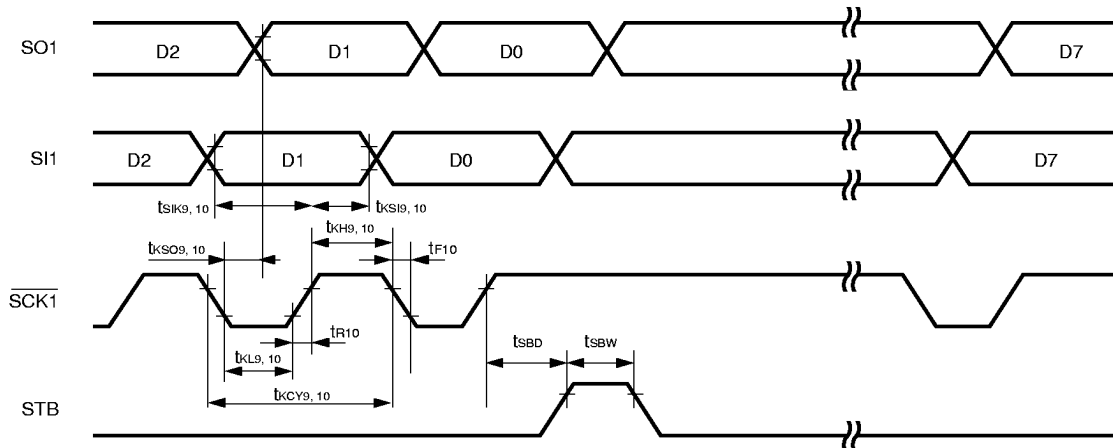

3-wire serial I/O mode with automatic transmit/receive function (busy processing) :

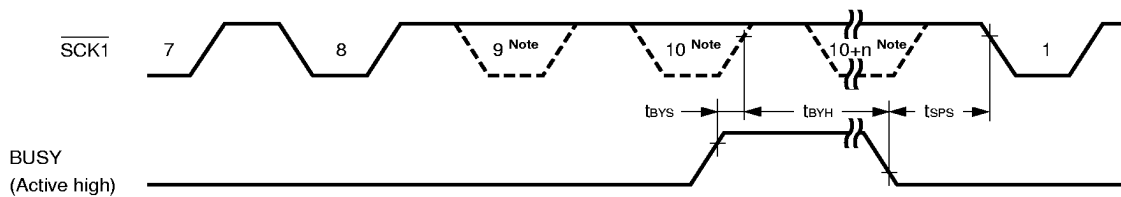

**Note** The signal is not actually driven low here; it is shown as such to indicate the timing.

UART mode (external clock input) :

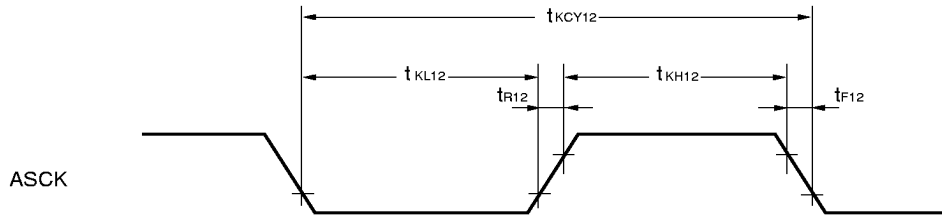

A/D Converter Characteristics ( $T_A = -40$  to  $+85^\circ\text{C}$ ,  $AV_{DD} = V_{DD} = 2.0$  to  $6.0$  V,  $AV_{SS} = V_{SS} = 0$  V)

Parameter	Symbol	Test Conditions	MIN.	TYP.	MAX.	Unit
Resolution			8	8	8	bit
★ Overall error <sup>Note</sup>		$2.7\text{ V} \leq AV_{REF0} \leq AV_{DD}$			$\pm 0.6$	%
		$2.0\text{ V} \leq AV_{REF0} < 2.7\text{ V}$			$\pm 1.4$	%
Conversion time	$t_{CONV}$		19.1		200	$\mu\text{s}$
Sampling time	$t_{SAMP}$		$12/f_{XX}$			$\mu\text{s}$
Analog input voltage	$V_{IAN}$		$AV_{SS}$		$AV_{REF0}$	V
Reference voltage	$AV_{REF0}$		2.0		$AV_{DD}$	V
Resistance between $AV_{REF0}$ and $AV_{SS}$	$R_{AIREF0}$		4	14		k $\Omega$

**Note** Overall error excluding quantization error ( $\pm 1/2$  LSB). It is indicated as a ratio to the full-scale value.

**Remark**  $f_{XX}$  : Main system clock frequency ( $f_x$  or  $f_x/2$ )  
 $f_x$  : Main system clock oscillation frequency

D/A Converter Characteristics ( $T_A = -40$  to  $+85^\circ\text{C}$ ,  $V_{DD} = 2.0$  to  $6.0$  V,  $AV_{SS} = V_{SS} = 0$  V)

Parameter	Symbol	Test Conditions	MIN.	TYP.	MAX.	Unit
Resolution					8	bit
Overall error		$R = 2\text{M}\Omega$ <b>Note 1</b>			1.2	%
		$R = 4\text{M}\Omega$ <b>Note 1</b>			0.8	%
		$R = 10\text{M}\Omega$ <b>Note 1</b>			0.6	%
Settling time		<sup>Note 1</sup> $C=30\text{pF}$ $4.5\text{ V} \leq AV_{REF1} \leq 6.0\text{ V}$			10	$\mu\text{s}$
		$2.7\text{ V} \leq AV_{REF1} < 4.5\text{ V}$			15	$\mu\text{s}$
		$2.0\text{ V} \leq AV_{REF1} < 2.7\text{ V}$			20	$\mu\text{s}$
Output resistance	$R_o$	DACS0, DACS1 = 55H <b>Note 2</b>		10		k $\Omega$
Analog reference voltage	$AV_{REF1}$		2.0		$V_{DD}$	V
$AV_{REF1}$ current	$I_{REF1}$	<b>Note 2</b>			1.5	mA

**Notes** 1. R and C denote D/A converter output pin load resistance and load capacitance, respectively.  
 2. Value for 1 D/A converter channel

**Remark** DACS0 and DACS1: D/A conversion value setting register 0 and 1

Data Memory STOP Mode Low Supply Voltage Data Retention Characteristics (T<sub>A</sub> = -40 to +85°C)

Parameter	Symbol	Test Conditions	MIN.	TYP.	MAX.	Unit
Data retention power supply voltage	V <sub>DDDR</sub>		1.8		6.0	V
Data retention power supply current	I <sub>DDDR</sub>	V <sub>DDDR</sub> = 1.8 V Subsystem clock stop and feed-back resistor disconnected		0.1	10	μA
Release signal set time	t <sub>SREL</sub>		0			μs
Oscillation stabilization wait time	t <sub>WAIT</sub>	Release by $\overline{\text{RESET}}$		2 <sup>17</sup> /f <sub>x</sub>		ms
		Release by interrupt request		<b>Note</b>		ms

**Note** In combination with bits 0 to 2 (OSTS0 to OSTS2) of oscillation stabilization time select register (OSTS), selection of 2<sup>12</sup>/f<sub>xx</sub> and 2<sup>14</sup>/f<sub>xx</sub> to 2<sup>17</sup>/f<sub>xx</sub> is possible.

**Remark** f<sub>xx</sub> : Main system clock frequency (f<sub>x</sub> or f<sub>x</sub>/2)  
f<sub>x</sub> : Main system clock oscillator frequency

Data Retention Timing (STOP Mode Release by  $\overline{\text{RESET}}$ )

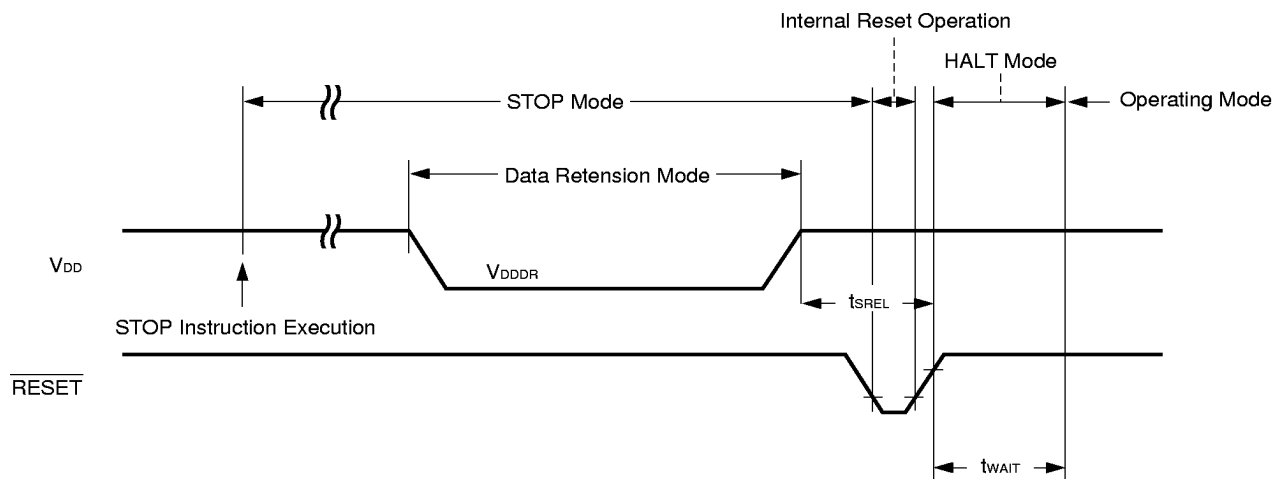

Data Retention Timing (Standby Release Signal: STOP Mode Release by Interrupt Request Signal)

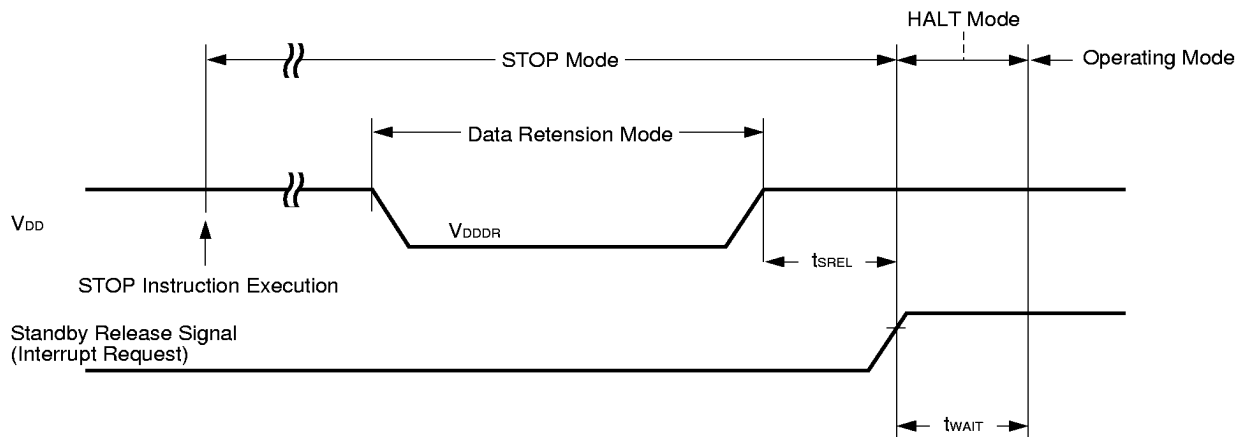

Interrupt Request Input Timing

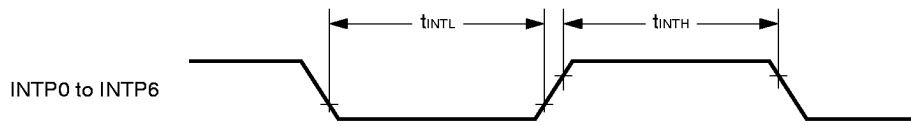

RESET Input Timing

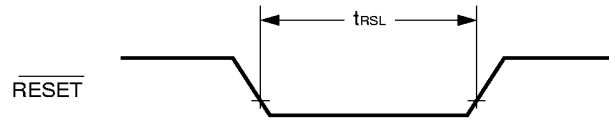



12. CHARACTERISTIC CURVES (REFERENCE VALUE)

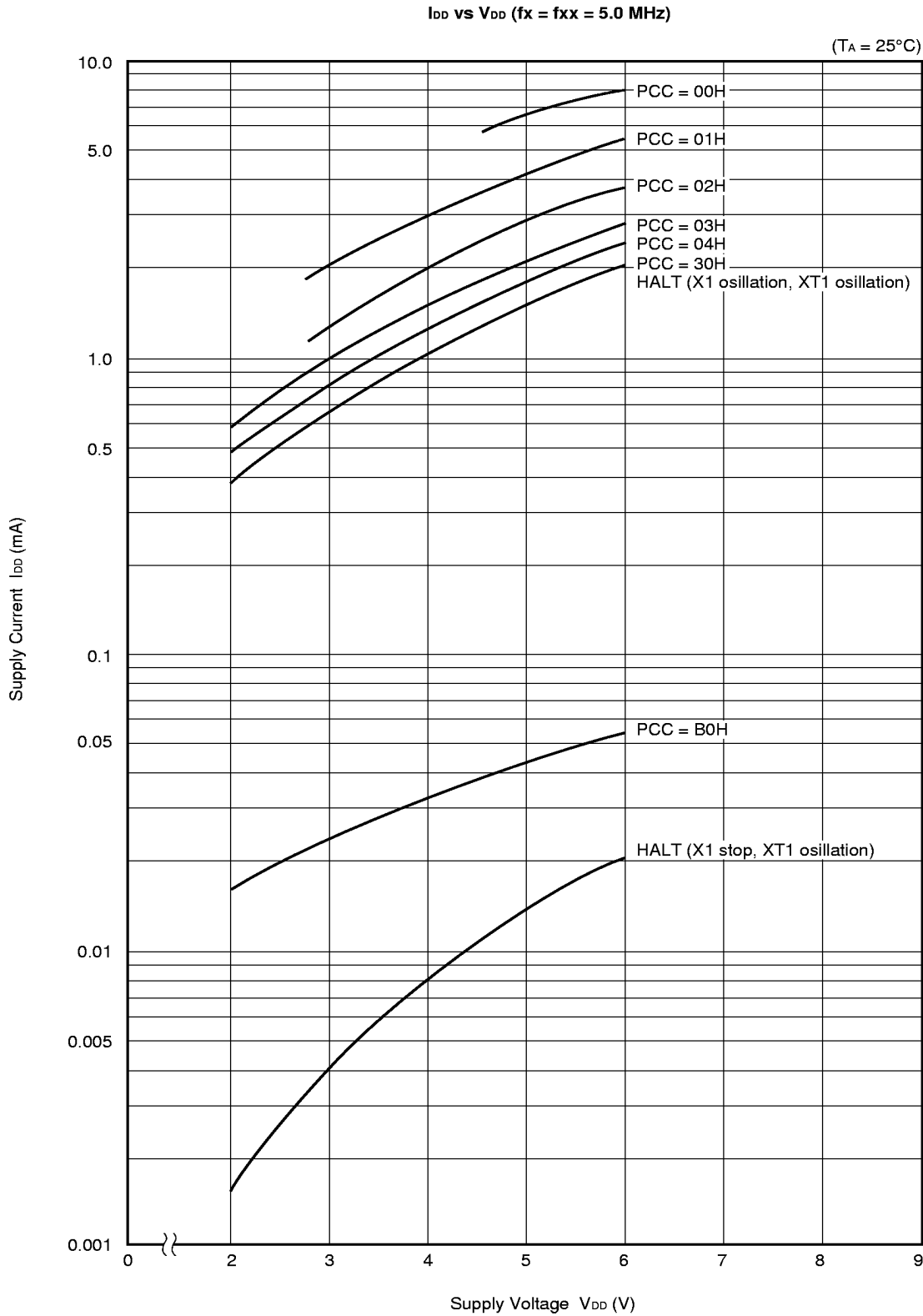

I<sub>DD</sub> vs V<sub>DD</sub> (fx = 5.0 MHz, fxx = 2.5 MHz)

(T<sub>A</sub> = 25°C)

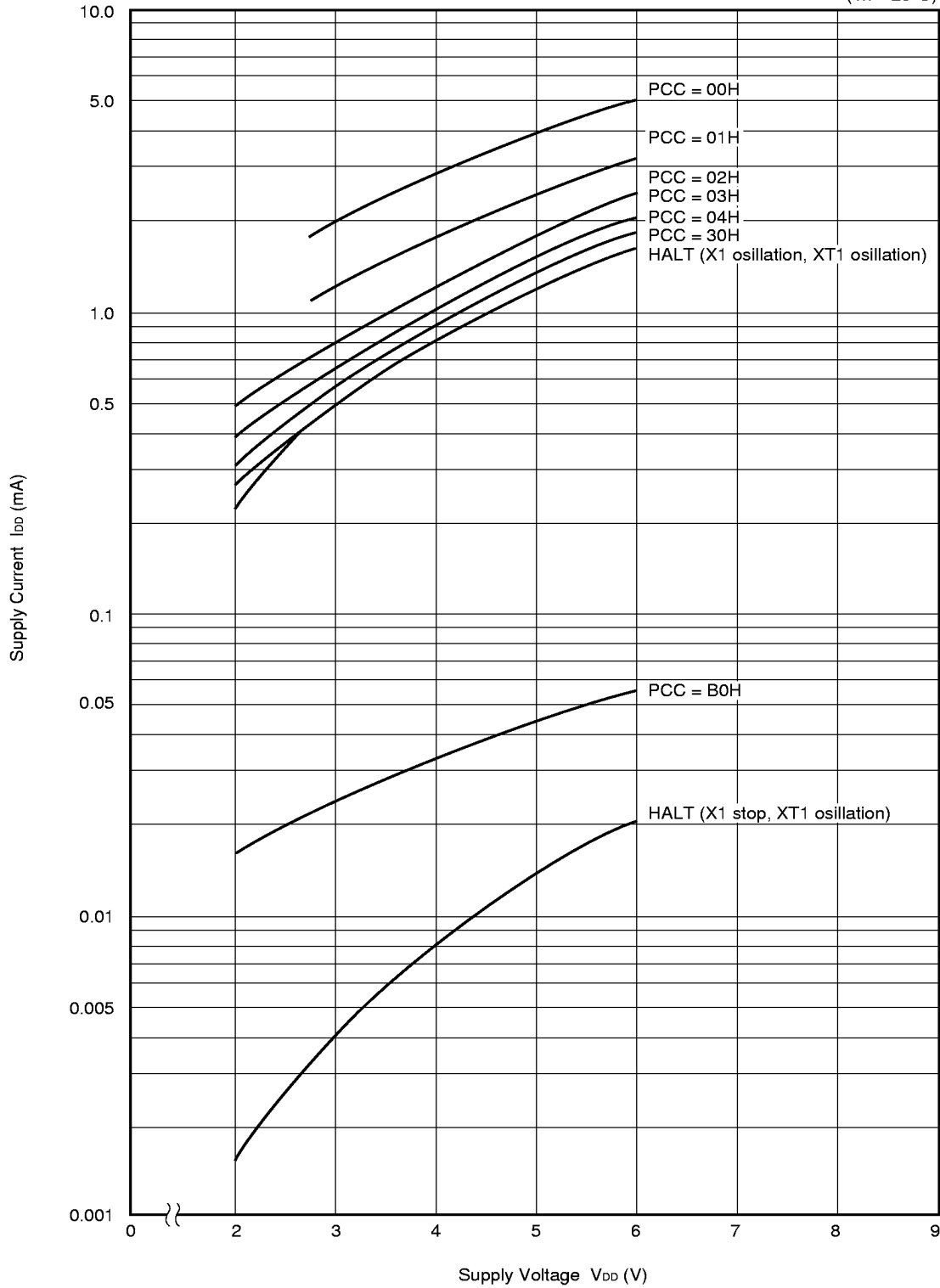

13. PACKAGE DRAWINGS

80 PIN PLASTIC QFP (14×14)

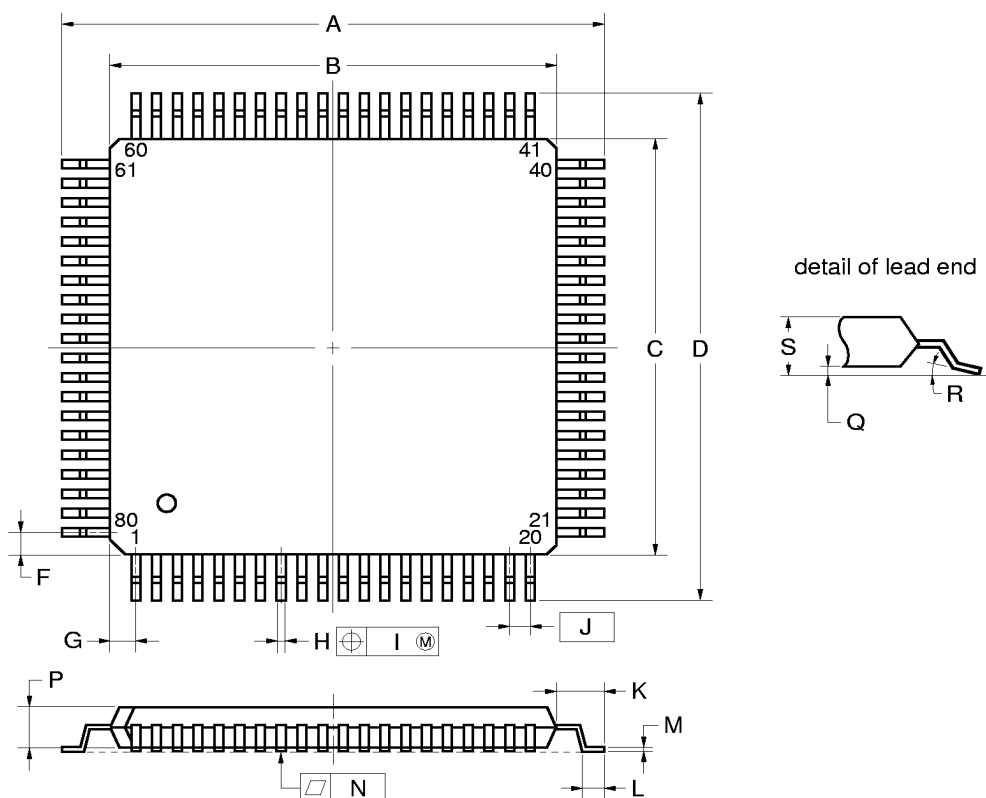

NOTE

Each lead centerline is located within 0.13 mm (0.005 inch) of its true position (T.P.) at maximum material condition.

ITEM	MILLIMETERS	INCHES
A	17.20±0.20	0.677±0.008
B	14.00±0.20	0.551 <sup>+0.009</sup> <sub>-0.008</sub>
C	14.00±0.20	0.551 <sup>+0.009</sup> <sub>-0.008</sub>
D	17.20±0.20	0.677±0.008
F	0.825	0.032
G	0.825	0.032
H	0.32±0.06	0.013 <sup>+0.002</sup> <sub>-0.003</sub>
I	0.13	0.005
J	0.65 (T.P.)	0.026 (T.P.)
K	1.60±0.20	0.063±0.008
L	0.80±0.20	0.031 <sup>+0.009</sup> <sub>-0.008</sub>
M	0.17 <sup>+0.03</sup> <sub>-0.07</sub>	0.007 <sup>+0.001</sup> <sub>-0.003</sub>
N	0.10	0.004
P	1.40±0.10	0.055±0.004
Q	0.125±0.075	0.005±0.003
R	3° <sup>+7°</sup> <sub>-3°</sub>	3° <sup>+7°</sup> <sub>-3°</sub>
S	1.70 MAX.	0.067 MAX.

P80GC-65-8BT

**Remark** Dimensions and materials of ES product are the same as those of mass-production products.

80 PIN PLASTIC TQFP (FINE PITCH) (12 × 12)

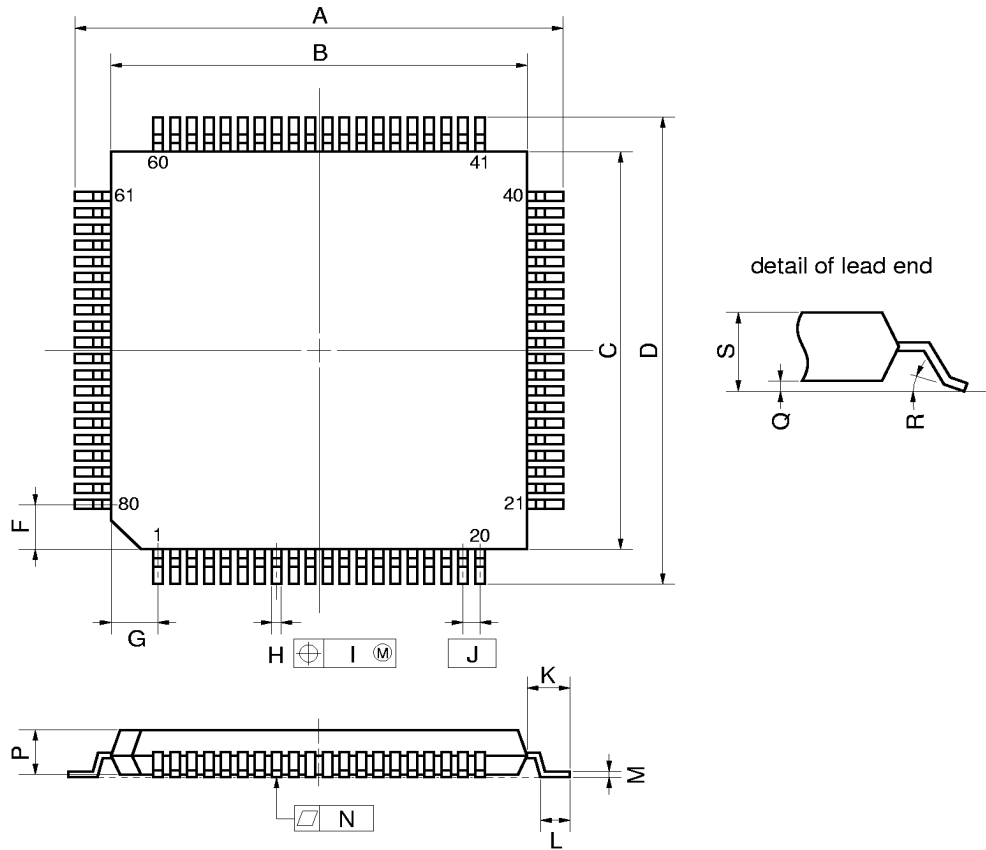

**NOTE**  
Each lead centerline is located within 0.10 mm (0.004 inch) of its true position (T.P.) at maximum material condition.

ITEM	MILLIMETERS	INCHES
A	14.0±0.2	0.551 <sup>+0.009</sup> <sub>-0.008</sub>
B	12.0±0.2	0.472 <sup>+0.009</sup> <sub>-0.008</sub>
C	12.0±0.2	0.472 <sup>+0.009</sup> <sub>-0.008</sub>
D	14.0±0.2	0.551 <sup>+0.009</sup> <sub>-0.008</sub>
F	1.25	0.049
G	1.25	0.049
H	0.22 <sup>+0.05</sup> <sub>-0.04</sub>	0.009±0.002
I	0.10	0.004
J	0.5 (T.P.)	0.020 (T.P.)
K	1.0±0.2	0.039 <sup>+0.009</sup> <sub>-0.008</sub>
L	0.5±0.2	0.020 <sup>+0.008</sup> <sub>-0.009</sub>
M	0.145 <sup>+0.055</sup> <sub>-0.045</sub>	0.006±0.002
N	0.10	0.004
P	1.05	0.041
Q	0.05±0.05	0.002±0.002
R	5°±5°	5°±5°
S	1.27 MAX.	0.050 MAX.

P80GK-50-BE9-4

**Remark** Dimensions and materials of ES product are the same as those of mass-production products.

14. RECOMMENDED SOLDERING CONDITIONS

This product should be soldered and mounted under the conditions recommended in the table below.

For detail of recommended soldering conditions, refer to the information document **Semiconductor Device Mounting Technology Manual (C10535E)**.

For soldering methods and conditions other than those recommended below, contact our sales personnel.

Table 14-1. Surface Mounting Type Soldering Conditions (1/2)

- ★ (1) μPD78052GC-xxx-8BT : 80-pin plastic QFP (14 × 14 mm)
- μPD78053GC-xxx-8BT : 80-pin plastic QFP (14 × 14 mm)
- μPD78054GC-xxx-8BT : 80-pin plastic QFP (14 × 14 mm)
- μPD78055GC-xxx-8BT : 80-pin plastic QFP (14 × 14 mm)
- μPD78056GC-xxx-8BT : 80-pin plastic QFP (14 × 14 mm)
- μPD78058GC-xxx-8BT : 80-pin plastic QFP (14 × 14 mm)

Soldering Method	Soldering Conditions	Recommended Condition Symbol
Infrared reflow	Package peak temperature: 235°C, Duration: 30 sec. max. (at 210°C or above), Number of times: Twice max.	IR35-100-2
VPS	Package peak temperature: 215°C, Duration: 40 sec. max. (at 200°C or above), Number of times: Twice max.	VP15-100-2
Wave soldering	Solder bath temperature: 260°C or less, Duration: 10 sec. max. Number of times: Once Preparatory heating temperature: 120°C max. (package surface temperature) Time limit: 7 days <sup>Note</sup> (thereafter 10 hours 125°C prebaking required)	WS60-100-1
Partial Heating	Pin temperature: 300°C max. Duration: 3 sec. max. (per device side)	—

**Caution** Use of more than one soldering method should be avoided (except in the case of partial heating).

Table 14-1. Surface Mounting Type Soldering Conditions (2/2)

(2)  $\mu$ PD78052GK-xxx-BE9 : 80-pin plastic TQFP (12 × 12 mm)

$\mu$ PD78053GK-xxx-BE9 : 80-pin plastic TQFP (12 × 12 mm)

$\mu$ PD78054GK-xxx-BE9 : 80-pin plastic TQFP (12 × 12 mm)

$\mu$ PD78055GK-xxx-BE9 : 80-pin plastic TQFP (12 × 12 mm)

$\mu$ PD78056GK-xxx-BE9 : 80-pin plastic TQFP (12 × 12 mm)

$\mu$ PD78058GK-xxx-BE9 : 80-pin plastic TQFP (12 × 12 mm)

Soldering Method	Soldering Conditions	Recommended Condition Symbol
Infrared reflow	Package peak temperature: 235°C, Duration: 30 sec. max. (at 210°C or above), Number of times: Thrice max., Time limit: 7 days <b>Note</b> (thereafter 10 hours 125°C prebaking required) <b>&lt;Precautions&gt;</b> Baking cannot be applied to other than heat-resistant trays (magazine, taping, non-heat-resistant trays) when the product is wrapped.	IR35-107-3
VPS	Package peak temperature: 215°C, Duration: 40 sec. max. (at 200°C or above), Number of times: Thrice max., Time limit: 7 days <b>Note</b> (thereafter 10 hours 125°C prebaking required) <b>&lt;Precautions&gt;</b> Baking cannot be applied to other than heat-resistant trays (magazine, taping, non-heat-resistant trays) when the product is wrapped.	VP15-107-3
Partial Heating	Pin temperature: 300°C max. Duration: 3 sec. max. (per device side)	—

**Note** For the storage period after dry-pack decompression storage conditions are max. 25°C, 65% RH.

**Caution** Use of more than one soldering method should be avoided (except in the case of partial heating).

**APPENDIX A. DEVELOPMENT TOOLS**

The following tools are available for development of systems using the μPD78054 subseries:

**Language Processing Software**

RA78K/0 <sup>Note 1, 2, 3, 4</sup>	Assembler package common to 78K/0 series
CC78K/0 <sup>Note 1, 2, 3, 4</sup>	C compiler package common to 78K/0 series
DF78054 <sup>Note 1, 2, 3, 4</sup>	Device file for μPD78054 subseries
CC78K/0-L <sup>Note 1, 2, 3, 4</sup>	C compiler library source file common to 78K/0 series

**PROM Writing Tools**

PG-1500	PROM programmer
PA-78P054GC PA-78P054GK PA-78P054KK-T	Programmer adapter connectd to PG-1500
PG-1500 Controller <sup>Note 1, 2</sup>	Control program for PG-1500

**Debugging Tools**

	IE-78000-R	In-circuit emulator common to 78K/0 series
	IE-78000-R-A	In-circuit emulator common to 78K/0 series (for integrated debugger)
	IE-78000-R-BK	Break board common to 78K/0 series
	IE-780308-R-EM	Emulation board for evaluating μPD780308 subseries
★	IE-78000-R-SV3	Interface adapter and cable when using EWS for the host machine (for IE-78000-R-A)
★	IE-78000-98-IF-B	Interface adapter when using the PC-9800 series (except for notebook computers) for the host machine (for IE-78000-R-A)
★	IE-78000-98N-IF	Interface adapter and cable when using the PC-9800 series notebook computers for the host machine (for IE-78000-R-A)
★	IE-78000-98-IF-B	Interface adapter when using IBM/PC AT™ and its compatibles for the host machine (for IE-78000-R-A)
	EP-78230GC-R	Emulation probe common to μPD78234 subseries
	EP-78054GK-R	Emulation probe for μPD78054 subseries
	EV-9200GC-80	Socket mounted to target system created for 80-pin plastic QFP (GC-8BT type)
	TGK-080SBW	Adapter mounted to target system created for 80-pin plastic TQFP (GK-BE9 Type). This is a product from TOKYO ELETECH CORPORATION (TEL (03) 5295-1661) When purchasing this product, please consult with NEC sales offices.
	SM78K/0 <sup>Note 5, 6, 7</sup>	System simulator common to 78K/0 series
	ID78K/0 <sup>Note 4, 5, 6, 7</sup>	Integrated debugger for IE-78000-R-A
	SD78K/0 <sup>Note 1, 2</sup>	Screen debugger for IE-78000-R
	DF78054 <sup>Note 1, 2, 4, 5, 6, 7</sup>	Device file for μPD78054 subseries

**Real-time OS**

RX78K/0 <sup>Note 1, 2, 3, 4</sup>	Real-time OS for 78K/0 series
MX78K/0 <sup>Note 1, 2, 3, 4</sup>	OS for 78K/0 series

**Fuzzy Inference Development Support System**

FE9000 <sup>Note 1</sup> /FE9200 <sup>Note 6</sup>	Fuzzy knowledge data creation tool
FT9080 <sup>Note 1</sup> /FT9085 <sup>Note 2</sup>	Translator
FI78K0 <sup>Note 1, 2</sup>	Fuzzy inference module
FD78K0 <sup>Note 1, 2</sup>	Fuzzy inference debugger

- Notes**
1. PC-9800 series (MS-DOS<sup>TM</sup>) based
  2. IBM PC/AT and its compatibles (PC DOS<sup>TM</sup>/IBM DOS<sup>TM</sup>/MS-DOS) based
  3. HP9000 series 300<sup>TM</sup> (HP-UX<sup>TM</sup>) based
  4. HP9000 series 700<sup>TM</sup> (HP-UX) based, SPARCstation<sup>TM</sup> (Sun OS<sup>TM</sup>) based, EWS4800 series (EWS-UX/V) based
  5. PC-9800 series (MS-DOS + Windows<sup>TM</sup>) based
  6. IBM PC/AT and compatible (PC DOS/IBM DOS/MS-DOS + Windows) based
  7. NEWS<sup>TM</sup> (NEWS-OS<sup>TM</sup>) based

- Remarks**
1. Please refer to the **78K/0 Series Selection Guide (U11126E)** for information on third party development tools.
  2. RA78K/0, CC78K/0, SM78K0, ID78K0, SD78K/0, and RX78K/0 are used in combination with DF78054.



**APPENDIX B. RELATED DOCUMENTS**

**Documents Related to Devices**

Document Name		Document No.	
		English	Japanese
μPD78054 and 78054Y subseries user's manual		U11747E	U11747J
μPD78052, 78053, 78054, 78055, 78056, 78058 data sheet		This document	U12327J
★	μPD78P054 Data Sheet	IC-3216	U12346J
★	μPD78P058 Data Sheet	U10417E	IC-8884
78K/0 series user's manual - instruction		U12326E	U12326J
78K/0 series instruction set		—	U10904J
78K/0 series instruction list		—	U10903J
μPD78054 subseries special function register table		—	U10102J
	78K/0 series application note	Fundamental (III)	U10182E
		Floating-point operation program volume	IEA-1289
		IEA-1289	IEA-718

**Development Tool Documents (User's Manual)**

Document Name		Document No.	
		English	Japanese
RA78K series assembler package	Operation	EEU-1399	EEU-809
	Language	EEU-1404	EEU-815
RA78K series structured assembler preprocessor		EEU-1402	U12323J
RA78K0 assembler package	Operation	U11802E	U11802J
	Assembly language	U11801E	U11801J
	Structured assembly language	U11789E	U11789J
CC78K series C compiler	Operation	EEU-1280	EEU-656
	Language	EEU-1284	EEU-655
CC78K0 C compiler	Operation	U11517E	U11517J
	Language	U11518E	U11518J
CC78K/0 C compiler application note	Programming know-how	EEA-1208	EEA-618
CC78K series library source file		—	U12322J
PG-1500 PROM programmer		U11940E	U11940J
PG-1500 controller PC-9800 series (MS-DOS) based		EEU-1291	EEU-704
PG-1500 controller IBM PC series (PC DOS) based		U10540E	EEU-5008
IE-78000-R		U11376E	U11376J
IE-78000-R-A		U10057E	U10057J
IE-78000-R-BK		EEU-1427	EEU-867
IE-780308-R-EM		U11362E	U11362J
EP-78230		EEU-1515	EEU-985
EP-78054GK-R		EEU-1468	EEU-932

**Caution** The documents listed above are subject to change without notice. Be sure to use the latest documents for designing your system.

Document Name		Document No.	
		English	Japanese
SM78K0 system simulator Windows based	Reference	U10181E	U10181J
SM78K series system simulator	External components user-open interface specification	U10092E	U10092J
ID78K0 integrated debugger EWS based	Reference	—	U11151J
ID78K0 integrated debugger PC based	Reference	U11539E	U11539J
ID78K0 integrated debugger Windows based	Guide	U11649E	U11649J
SD78K/0 screen debugger PC-9800 series (MS-DOS) based	Introduction	—	EEU-852
	Reference	—	U10952J
SD78K/0 screen debugger IBM PC/AT (PC DOS) based	Introduction	U10539E	EEU-5024
	Reference	U11279E	U11279J

**Documents Related to Embedded Software (User's Manual)**

Document Name		Document No.	
		English	Japanese
78K/0 series real-time OS	Fundamental	U11537E	U11537J
	Installation	U11536E	U11536J
78K/0 series OS MX78K0	Fundamental	U12257E	U12257J
Fuzzy knowledge data creation tool		EEU-1438	EEU-829
78K/0, 78K/II, 87AD series fuzzy inference development support system - translator		EEU-1444	EEU-862
78K/0 series fuzzy inference development support system - fuzzy inference module		EEU-1441	EEU-858
78K/0 series fuzzy inference development support system - fuzzy inference debugger		EEU-1458	EEU-921

**Other Related Documents**

Document Name		Document No.	
		English	Japanese
IC package manual		C10943X	
Semiconductor device mounting technology manual		C10535E	C10535J
Quality grade on NEC semiconductor devices		C11531E	C11531J
NEC semiconductor device reliability/quality control system		C10983E	C10983J
Guide to Prevent Damage for Semiconductor Devices by Electrostatic Discharge (ESD)		C11892E	C11892J
Semiconductor device quality guarantee guide		MEI-1202	C11893J
Product guide related to microcomputer - other manufacturers		—	U11416J

**Caution** The documents listed above are subject to change without notice. Be sure to use the latest documents for designing your system.