

Precision Adjustable Shunt Regulator

FEATURES

- Trimmed Bandgap Reference to 0.4%
- Wide Operating Current 1mA to 150mA
- Extended Temperature Range: -55°C to 125°C
- Low Temperature Coefficient 30 ppm/°C
- Offered in TO-92, SOIC, SOT-89, SOT-23-5
- Improved Replacement in Performance for LT1431
- Low Cost Solution

APPLICATIONS

- Battery Operating Equipment
- Adjustable Supplies
- Switching Power Supplies
- Error Amplifiers
- Single Supply Amplifier
- Monitors / VCRs / TVs
- Personal Computers

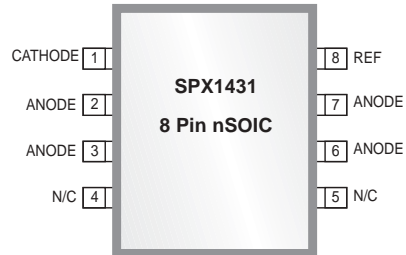

Now Available in Lead Free Packaging

DESCRIPTION

The SPX1431 is a 3-terminal adjustable shunt voltage regulator providing a highly accurate bandgap reference. The SPX1431 acts as an open-loop error amplifier with a 2.5V temperature compensation reference. The SPX1431's thermal stability, wide operating current (150mA) and temperature range (-55°C to 125°C) makes it suitable for a variety of applications that require a low cost, high performance solution. SPX1431 tolerance of 0.4% is proven to be sufficient to overcome all of the other errors in the system to virtually eliminate the need for trimming in the power supply manufacturer's assembly lines and contributes a significant cost savings.

The output voltage may be adjusted to any value between V_{REF} and 36 volts with two external resistors. The SPX1431 is available in TO-92, SOIC-8, SOT-89, and SOT-23-5 packages.

BLOCK DIAGRAM

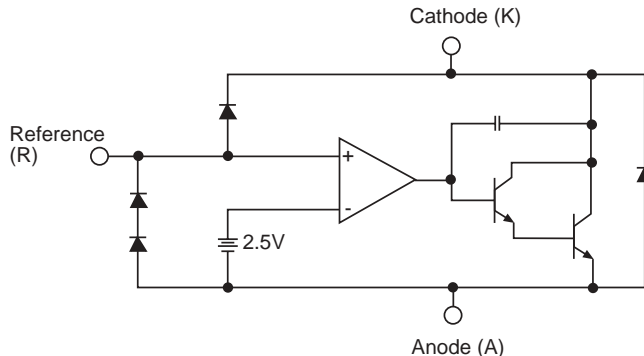

ABSOLUTE MAXIMUM RATINGS

Cathode-Anode Reverse Breakdown V_{KA}	37V
Anode-Cathode Forward Current, (<10ms) I_{AK}	1A
Operating Cathode Current I_{KA}	150mA
Reference Input Current I_{REF}	10mA
Continuous Power Dissipation at 25°C P_D	
TO-92	775mW
SOT-23	200 mW
SOIC-8	750mW
SOT-89	1000mW

Junction Temperature T_J	150 °C
Storage Temperature T_{STG}	-65 to 150 °C
Lead Temperature (Soldering 10 sec.) T_L	300°C

NOTE: Stresses greater than those listed under ABSOLUTE MAXIMUM RATINGS may cause permanent damage to the device. This is a stress rating only and functional operation of the device at these or any other conditions above those indicated in the operational sections of this specification is not implied. Exposure to absolute maximum rating conditions for extended periods may affect reliability.

RECOMMENDED CONDITIONS

PARAMETER	SYMBOL	RATING	UNIT
Cathode Voltage	V_{KA}	V_{REF} to 36	V
Cathode Current	I_K	10	mA

TYPICAL THERMAL RESISTANCES

PACKAGE	θ_{JA}	θ_{JC}	TYPICAL DERATING
TO-92	160°C/W	80°C/W	6.3 mW/°C
SOT-23	575°C/W	150°C/W	1.7 mW/°C
SOIC-8	175°C/W	45°C/W	5.7 mW/°C
SOT-89	110°C/W	8°C/W	9.1mW/C°

Typical deratings of the thermal resistances are given for ambient temperature >25°C.

ELECTRICAL CHARACTERISTICS

Electrical characteristics at 25°C $I_K = 10mA$ $V_K = V_{REF}$, unless otherwise specified.

PARAMETER	SYMBOL	FIGURE	CONDITIONS	MIN	TYP	MAX	UNITS
SPX1431							
Reference Voltage	V_{REF}	2	$T_J = 0^\circ\text{C to } 105^\circ\text{C}$	2.490	2.500	2.510	V
		2		2.465		2.535	V
ΔV_{REF} with Temp.*	TC	2			0.07	0.20	mV/°C
Ratio of Change in V_{REF} to Cathode Voltage	$\frac{\Delta V_{REF}}{\Delta V_K}$	3	$V_K = 3V \text{ to } 36V$	-2.0	-1.1		mV/V
Reference Input Current	I_{REF}	3			0.7	1.9	μA
I_{REF} Temp Deviation	ΔI_{REF}	3	$T_J = 0^\circ\text{C to } 105^\circ\text{C}$		0.4	1.2	μA
Min I_K for Regulation	$I_{K(MIN)}$	2			0.4	1	mA
Off State Leakage	$I_{K(OFF)}$	4	$V_{REF} = 0V,$ $V_{KA} = 36V$		0.04	250	nA
Dynamic Output Impedance	Z_{KA}	2	$f_z \leq 1\text{kHz}$ $I_K = 1 \text{ to } 150\text{mA}$		0.15	0.5	Ω

Operating Range (T_J) = - 55°C to 125°C.

*** See appropriate test circuit (Figure 2)**

CALCULATING AVERAGE TEMPERATURE COEFFICIENT (TC)

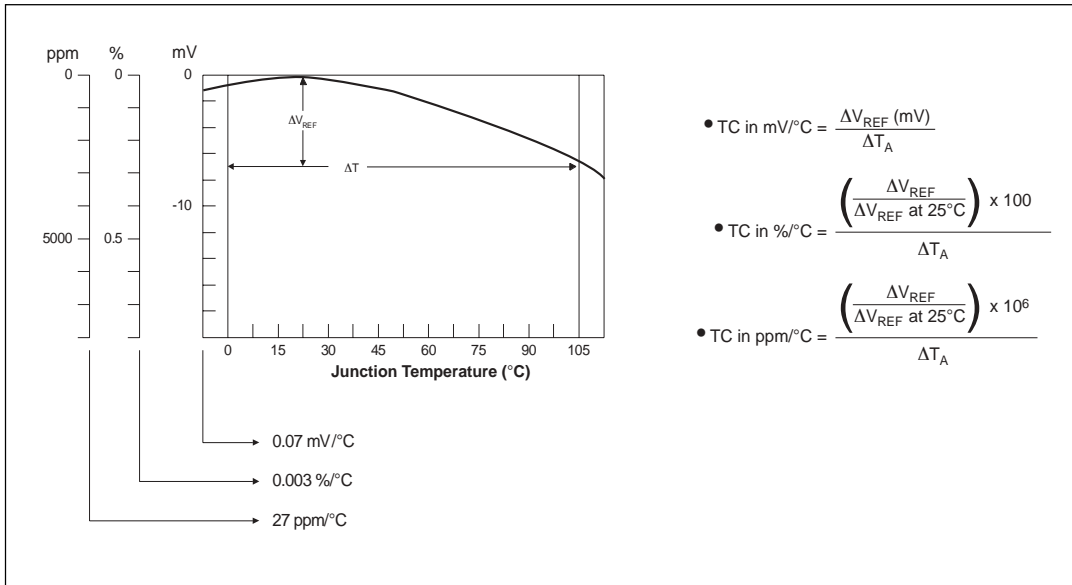

Figure 1. V_{REF} VS Temperature.

TEST CIRCUITS

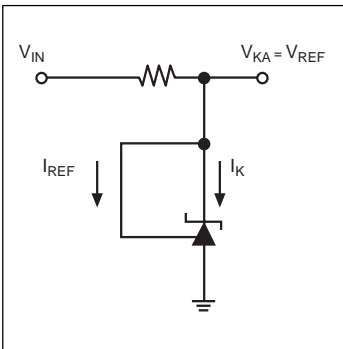

Figure 2. Test Circuit for $V_{KA} = V_{REF}$

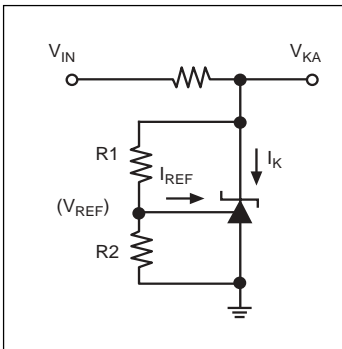

Figure 3. Test Circuit for $V_{KA} > V_{REF}$

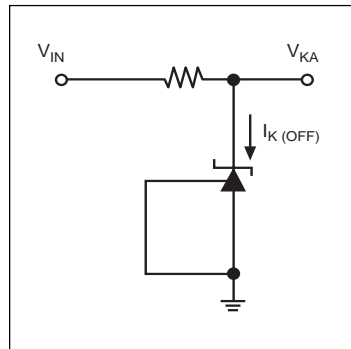

Figure 4. Test Circuit for $I_{K(OFF)}$

TYPICAL PERFORMANCE CHARACTERISTICS

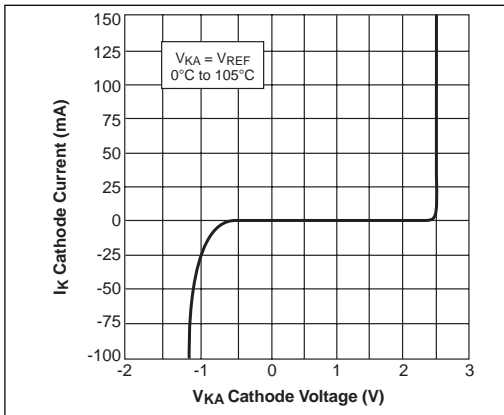

Figure 5. High Current Operating Characteristics

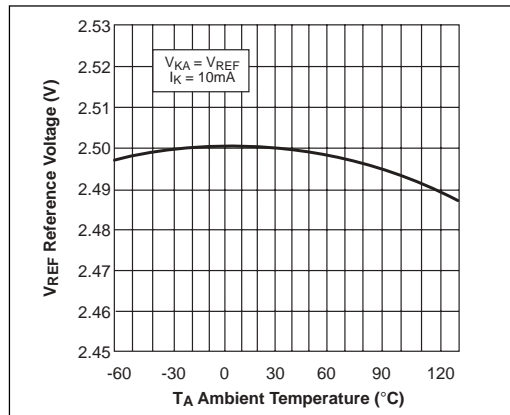

Figure 6. Reference Voltage VS Ambient Temperature

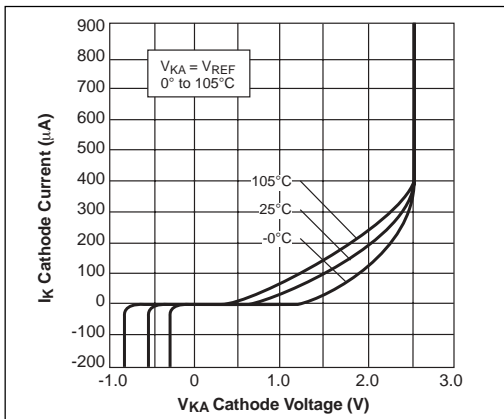

Figure 7. Low Current Operating Characteristics

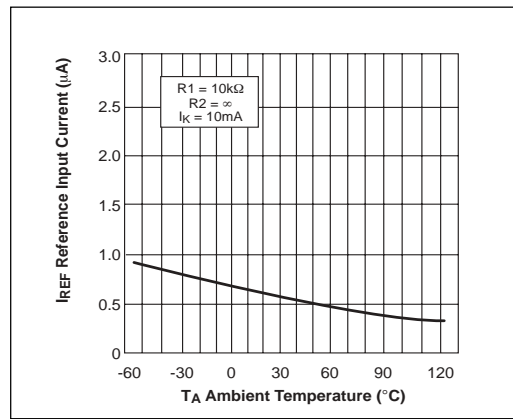

Figure 8. Reference Input Current VS Ambient Temperature

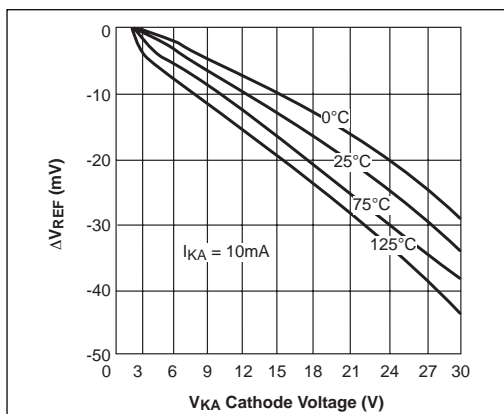

Figure 9. Reference Voltage Line Regulation VS Cathode Voltage and $T_{AMBIENT}$

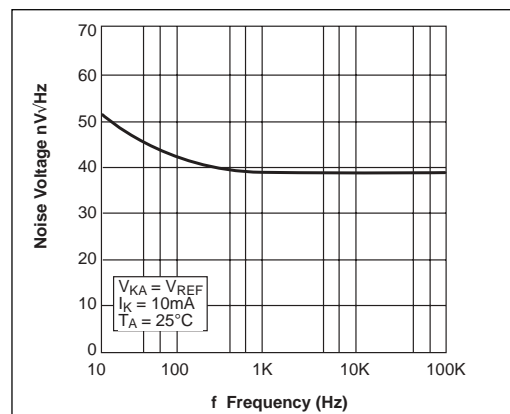

Figure 10. Noise Voltage VS Frequency

TYPICAL PERFORMANCE CHARACTERISTICS

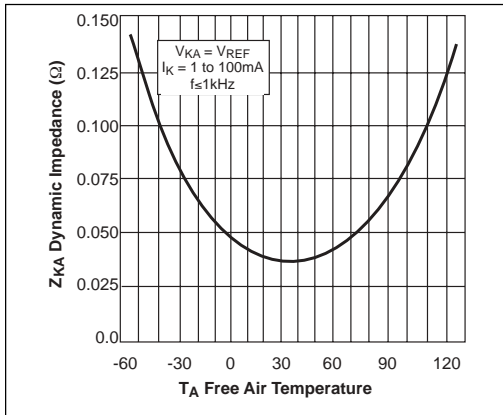

Figure 11. Low Frequency Dynamic Output Impedance VS $T_{AMBIENT}$

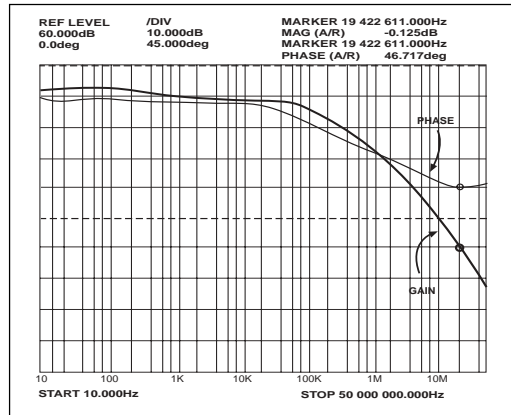

Figure 12. Small Signal Gain and Phase VS Frequency; $I_K = 10mA$, $T_A = 25^\circ C$

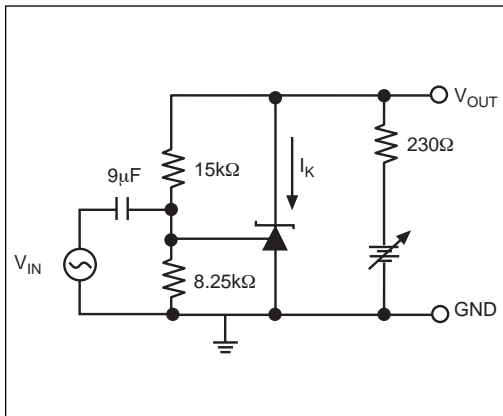

Figure 13. Test Circuit for Gain and Phase Frequency Response

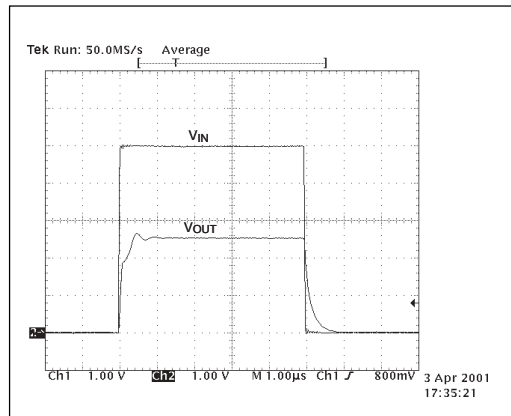

Figure 14. Frequency = 100kHz, $I_K = 10mA$, $T_A = 25^\circ C$

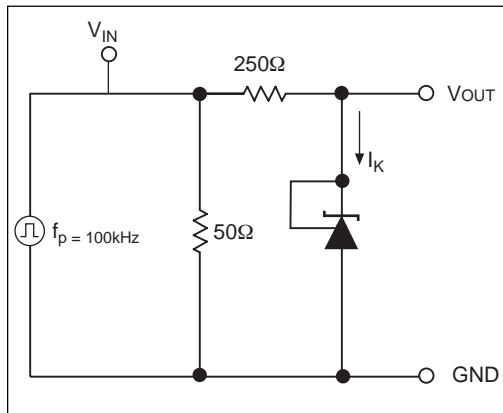

Figure 15. Test Circuit for Pulse Response

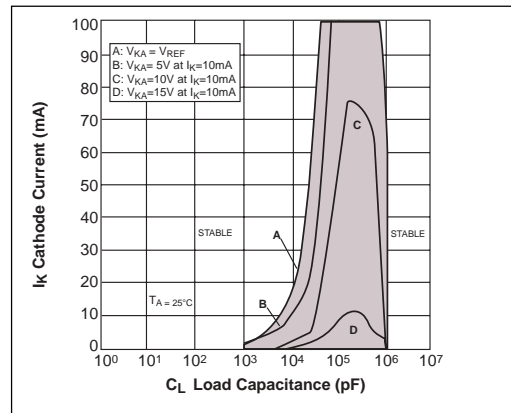

Figure 16. Stability Boundary Conditions

TYPICAL PERFORMANCE CHARACTERISTICS

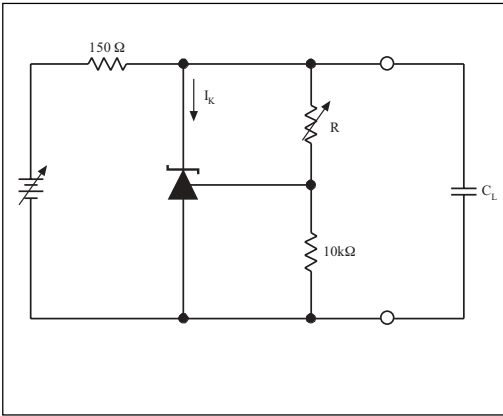

Figure 17. Test Circuit for Stability

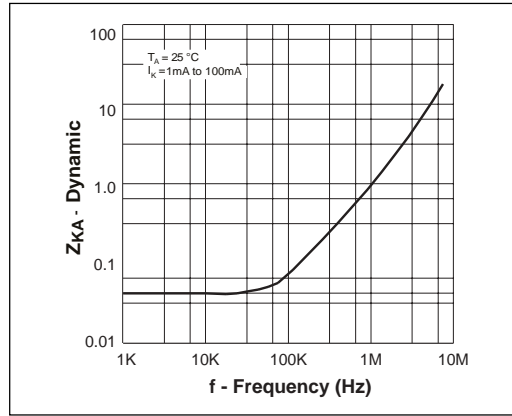

Figure 18. Dynamic Output Impedance $T_A = 25^\circ\text{C}$, $I_k = 1$ to 100mA

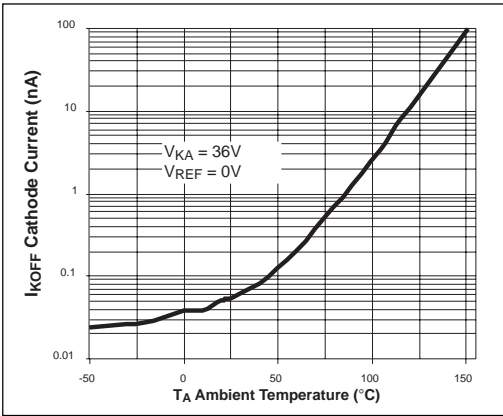

Figure 19. Off State Leakage

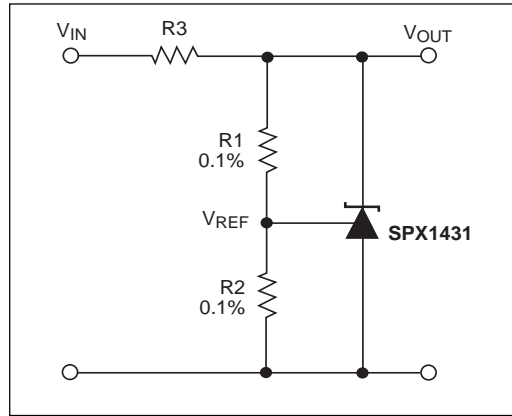

Figure 20. Shunt Regulator $V_{OUT} = (1+R1/R2)V_{REF}$

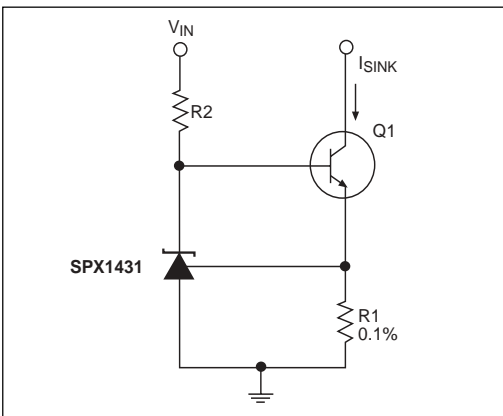

Figure 21. Constant Current, Sink, $I_{SINK} = V_{REF}/R1$

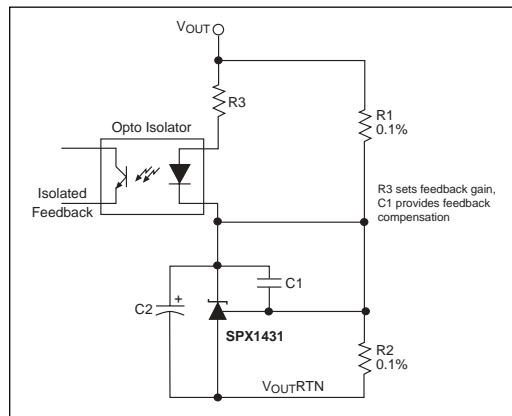

Figure 22. Reference Amplifier for Isolated Feedback in Off-Line DC-DC Converters

TYPICAL PERFORMANCE CHARACTERISTICS

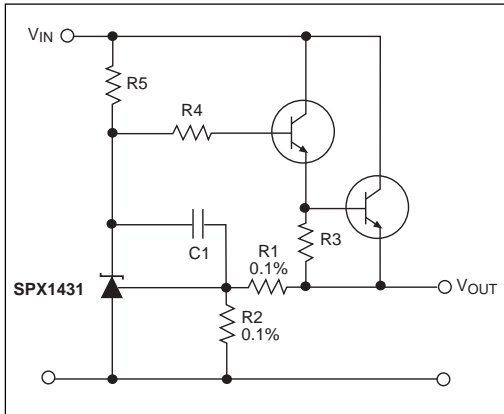

Figure 23. Precision High Current Series Regulator
 $V_{OUT} = (1+R1/R2)V_{REF}$

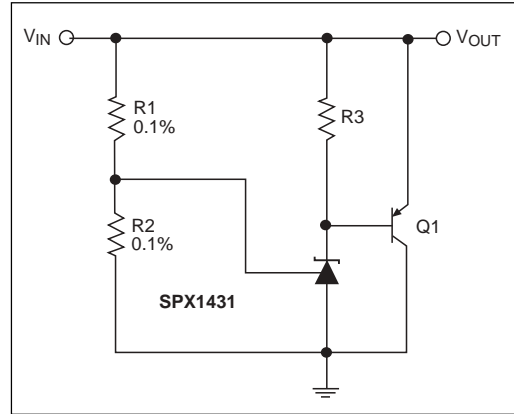

Figure 24. High Current Shunt Regulator
 $V_{OUT} = (1+R1/R2)V_{REF}$

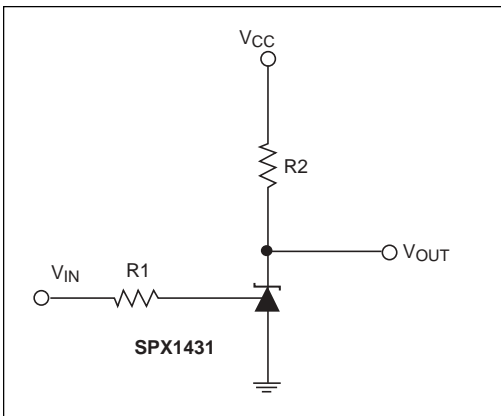
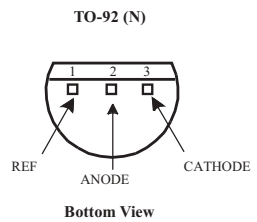
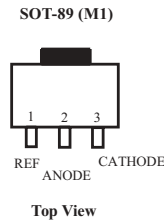
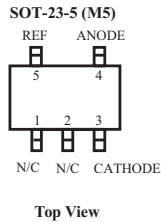
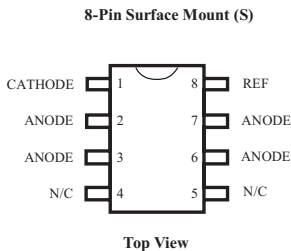
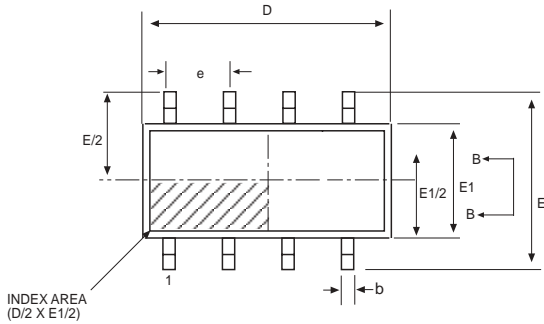

Figure 25. Single Supply Comparator with Temperature Compensated Threshold. V_{IN} threshold = 2.5V

* Resistor values are chosen such that the effect to I_{REF} is negligible.

PACKAGE PINOUTS





TOP VIEW

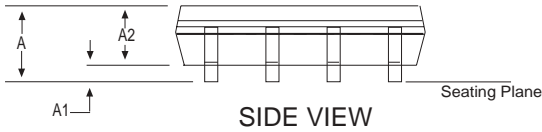
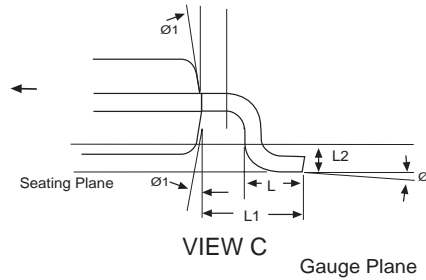
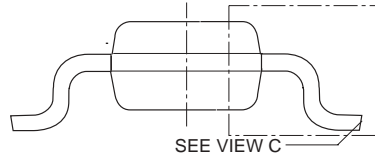

SIDE VIEW

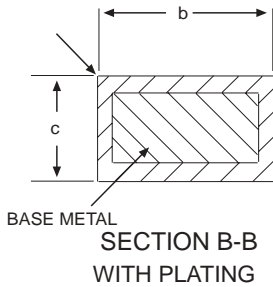

8 Pin NSOIC (JEDEC MS-012, AA - VARIATION)	DIMENSIONS in (mm)			
	SYMBOL	MIN	NOM	MAX
	A	1.35	-	1.75
	A1	0.10	-	0.25
	A2	1.25	-	1.65
	b	0.31	-	0.51
	c	0.17	-	0.25
	D	4.90 BSC		
	E	6.00 BSC		
	E1	3.90 BSC		
	e	1.27 BSC		
	L	0.40	-	1.27
	L1	1.04 REF		
	L2	0.25 BSC		
	Ø	0°	-	8°
	Ø1	5°	-	15°

8 PIN NSOIC

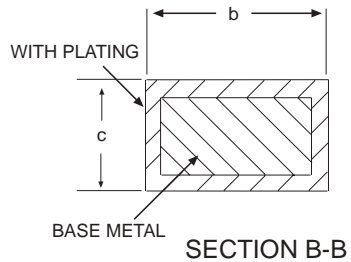
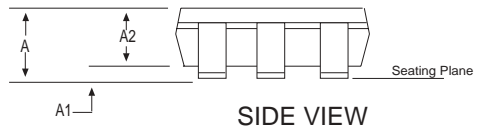
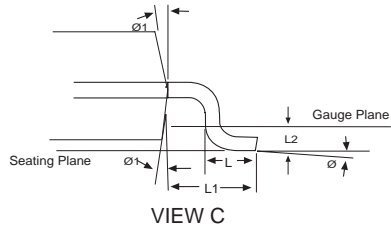
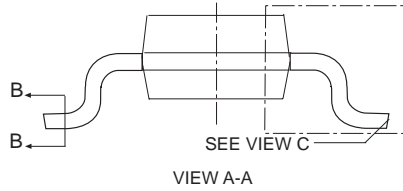
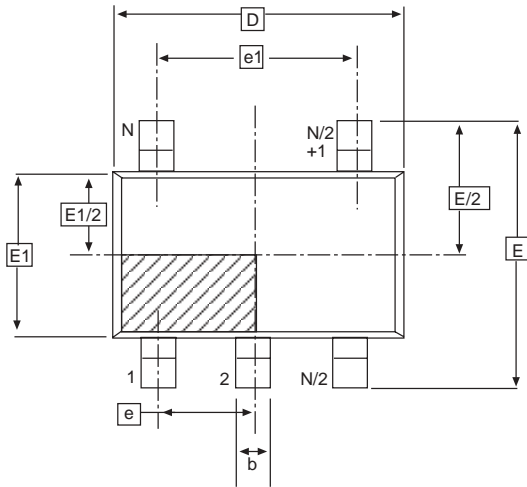

5 PIN SOT-23 JEDEC MO-178 (AA) Variation	Dimensions in (mm)		
	MIN	NOM	MAX
A	-	-	1.45
A1	0	-	0.15
A2	0.90	1.15	1.30
b	0.30	-	0.50
c	0.08	-	0.22
D	2.90 BSC		
E	2.80 BSC		
E1	1.60 BSC		
e	0.95 BSC		
e1	1.90 BSC		
L	0.30	0.45	0.60
L1	0.60 REF		
L2	0.25 BSC		
ϕ	0°	4°	8°
$\phi 1$	5°	10°	15°

5 PIN SOT-23

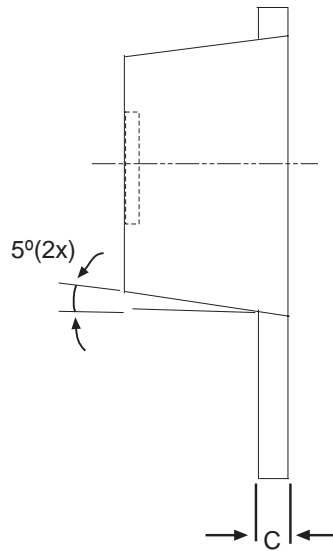
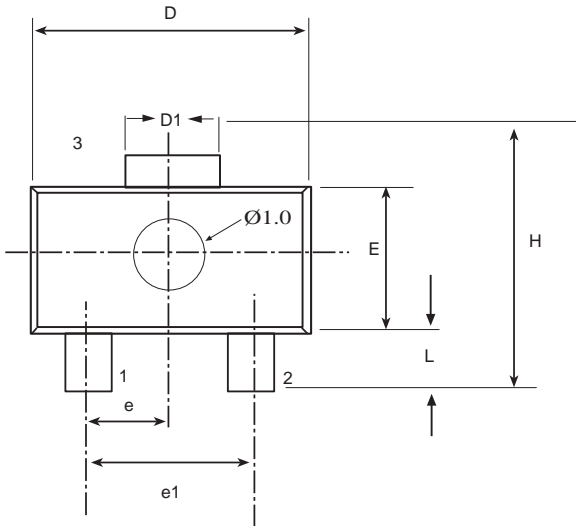

3 PIN SOT-89	Dimensions in (mm)		
	MIN	NOM	MAX
A	1.40	1.50	1.60
b	0.36	0.42	0.48
L	0.80	-	1.20
b1	0.41	0.47	0.53
C	0.38	0.40	0.43
D	4.40	4.50	4.60
D1	1.40	1.60	1.75
H	3.94	-	4.25
E	2.40	2.50	2.60
e	1.45	1.50	1.55
e1	2.90	3.00	3.10

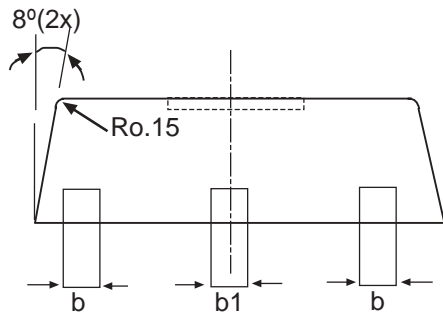

3 PIN SOT-89

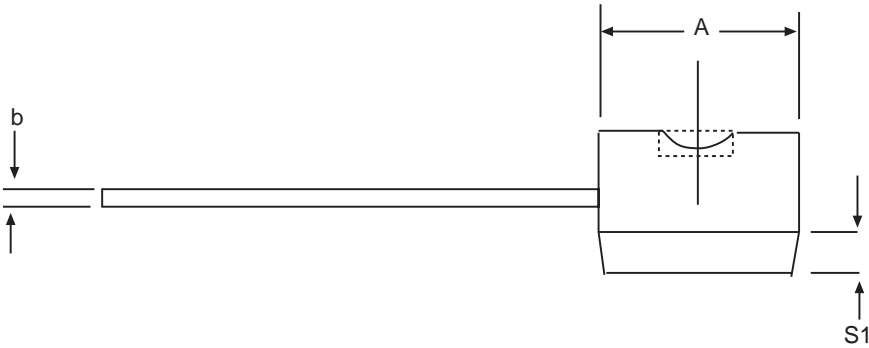
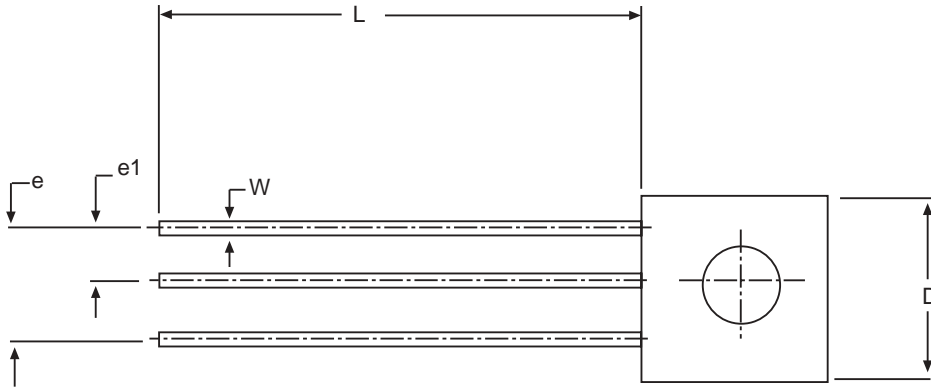

3 PIN TO-92	DIMENSIONS IN INCHES		
	MIN	NOM	MAX
A	.170	-	.195
b	.014	-	.020
E	.130	-	.155
e	.095	-	.105
e1	.045	-	.055
L	.500	-	.610
R	.085	-	.095
S1	.045	-	.060
W	.016	-	0.022
D	.175	-	.195
a	4°	-	6°

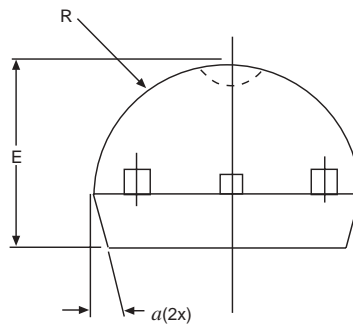

3 PIN TO-92

PART NUMBER	ACCURACY	OUTPUT VOLTAGE	PACKAGES
SPX1431M5	0.4%	2.5V	5-Pin SOT-23
SPX1431M5/TR	0.4%	2.5V	5-Pin SOT-23
SPX1431M1	0.4%	2.5V	3-Pin SOT-89
SPX1431M1/TR	0.4%	2.5V	3-Pin SOT-89
SPX1431S	0.4%	2.5V	8-Pin NSOIC
SPX1431S/TR	0.4%	2.5V	8-Pin NSOIC
SPX1431N	0.4%	2.5V	3-Pin TO-92
SPX1431N/TR	0.4%	2.5V	3-Pin TO-92

Available in lead free packaging. To order add "-L" suffix to part number.

Example: SPX1431S/TR = standard; SPX1431S-L/TR = lead free

/TR = Tape and Reel

Pack quantity is 2,000 for TO-92 and 2,500 for NSOIC, SOT-23 or SOT-89.



ANALOG EXCELLENCE

Sipex Corporation

**Headquarters and
Sales Office**
233 South Hillview Drive
Milpitas, CA 95035
TEL: (408) 934-7500
FAX: (408) 935-7600