





# DATA IMAGE CORPORATION

## LCD Module Specification

ITEM NO.: TG241610FFEBB-01

### Table of Contents

1. COVER & CONTENTS .....	1
2. RECORD OF REVISION .....	2
3. GENERAL SPECIFICATIONS .....	3
4. ABSOLUTE MAXIMUM RATINGS .....	4
5. ELECTRICAL CHARACTERISTICS .....	5
6. ELECTRO-OPTICAL CHARACTERISTIC .....	5
7. TIMING CHARACTERISTICS .....	9
8. PIN CONNECTIONS .....	13
9. POWER SUPPLY .....	13
10. BLOCK DIAGRAM .....	14
11. QUALITY ASSURANCE .....	16
12. LOT NUMBERING SYSTEM .....	20
13. LCM NUMBERING SYSTEM .....	20
14. PRECAUTIONS IN USE LCM .....	21
15. OUTLINE DRAWING .....	22
16. PACKAGE INFORMATION .....	23

R&D Dept.	Q.C. Dept.	Eng. Dept.	Prod. Dept.
			
Version:	Issued Date:	Sheet Code:	Total Pages:
C	2003/4/25		23

## 2. RECORD OF REVISION

Rev	Date	Item	Page	Comment
B	3/APR/03	15	21	ADD attach 3M tape on FPC.
C	25/APR/03			Change the PCB trace width that closed to the PIN to improve the HOT bar Process quality and update the PCB version from F to G.

### 3. GENERAL SPECIFICATION

Display Format : 240 (W) × 160 (H) dots  
Dot Size : 0.23 (W) × 0.23 (H) mm  
View Area : 60 (W) × 41 (H) mm  
Outline Dimensions : 70.5 (W) × 50.3 (H) × 6.3 (T) mm Max.  
Weight : g max.

LCD Type :  STN Gray  STN BLUE  FSTN  TN

Polarizer mode :  Reflective  Transflective

Transmissive  Negative  Paper white

View Angle :  6 O'clock  12 O'clock  Others

Backlight :  LED  EL  CCFL

Backlight Color :  Yellow green  Amber  Blue Green

White  Others

Controller / Driver : COM NT7701, SEG LH1562

Temperature Range :  Normal  Wide Temperature  
Operating 0 to 50°C Operating -20 to 70°C  
Storage -20 to 70°C Storage -30 to 80°C

## 4. ABSOLUTE MAXIMUM RATINGS

### 4.1 ELECTRICAL ABSOLUTE MAXIMUM RATINGS

$V_{SS} = 0V$ ,  $T_a = 25^{\circ}C$

Item	Symbol	Min.	Max.	Unit
Supply Voltage (Logic)	$V_{DD-VSS}$	0	7.0	V
Supply Voltage (LCD Driver)	$V_{LCD}$	0	30	V
Operating Temperature	$T_{OP}$	-20	70	$^{\circ}C$
Storage Temperature	$T_{STG}$	-30	80	$^{\circ}C$

### 4.2 ENVIRONMENTAL ABSOLUTE MAXIMUM RATINGS

Item	Operating		Storage		Comment
	(Min.)	Max.)	(Min.)	(Max.)	
Ambient Temp	-20	70	-30	80	Note (1)
Humidity	Note (2)		Note(2)		Without Condensation
Vibration	--	$4.9M/S^2$	--	$19.6M/S^2$	XYZ Direction
Shock	--	$29.4M/S^2$	--	$490M/S^2$	XYZ Direction

Note(1)  $T_a = 0^{\circ}C$  : 50Hr Max.

Note(2)  $T_a \leq 40^{\circ}C$  : 90% RH Max.

$T_a \geq 40^{\circ}C$  : Absolute humidity must be lower than the humidity of 90% RH at  $40^{\circ}C$ .

## 5. ELECTRICAL CHARACTERISTICS

Item	Symbol	Condition	Min.	Typ.	Max.	Unit	
Supply Voltage (Logic)	VDD-VSS		2.7	3.0	3.3	V	
Supply Voltage (LCD)	VLCD	-20°C	18.5	19	19.5	V	
		-10°C	17.6	18.1	18.6		
		25°C	16.5	17.5	18.0		
		70°C	15.7	16.2	16.7		
Input Voltage	V <sub>IH</sub>	--	0.8*VDD	--	VDD	V	
	V <sub>IL</sub>		VSS	--	0.2*VDD		
Logic Supply Current	IDD	LCD- ON- EL	ON	--	26.3	--	mA
			OFF		4.0	--	mA
		LCD- OFF-EL	OFF	--	0.15	--	mA

## 6. ELECTRO-OPTICAL CHARACTERISTICS

ITEM	Symbol	Condition	Min.	Typ.	Max.	Unit	Ref.
Rise Time	Tr	0°C	--	--	--	ms	Note (1)
		25°C		180	360		
Fall Time	Tf	0°C	--	--	--	ms	
		25°C		260	520		
Contrast	CR	25°C	2	4			Note (3)
View Angle	θ1-θ2 ∅1, ∅2	25°C & CR≥3	60	--	--		Note (2)
			90	--	--		
Frame Frequency	Ff	25°C	--	70	--	Hz	

Note (1) & (2) : See next page

Note (3) : Contrast ration is defined under the following condition:

$$CR = \frac{\text{Brightness of non-selected condition}}{\text{Brightness of selected condition}}$$

- ( a ). Temperature ----- 25°C
- ( b ). Frame frequency ---- 70Hz
- ( c ). Viewing angle ----- θ= 0°, ∅ = 0°
- ( d ). Operating voltage --- 17.5

Note (1) Response time is measured as the shortest period of time possible between the change in state of an LCD segment as demonstrated below:

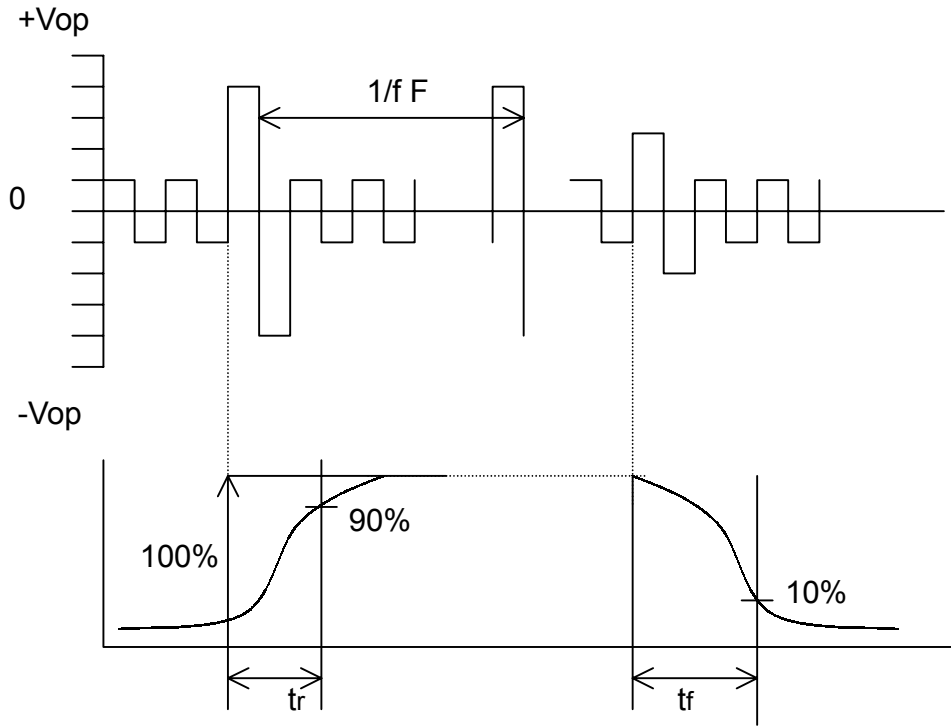

Condition:

- ( a ) . Temperature ----- $25^{\circ}C$
- ( b ) . Frame frequency ----- 70Hz
- ( c ) . View Angle -----  $\theta = 0^{\circ}$ ,  $\phi = 0^{\circ}$
- ( d ) . Operating voltage -----17.5

Note (2) Definition of View Angle

Top – Bottom direction

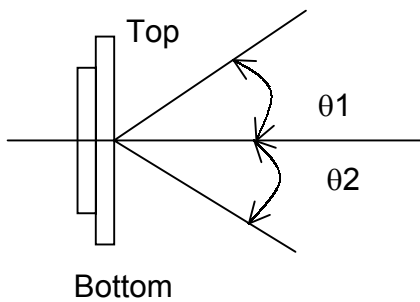

Right -- Left direction

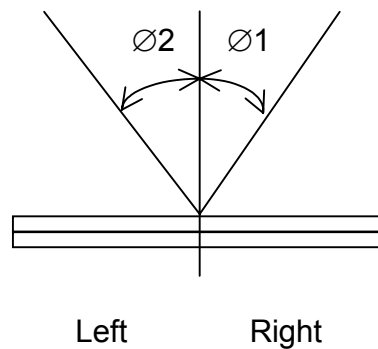

**6.1 ELECTRIC - OPTICAL CHARACTERISTIC**

( TEMP : 20°C )

ITEM	CONDITION	DIMENSION		STANDARD		
				MIN	TYP	MAX
BRIGHTNESS	400Hz,100Vrms SINE WAVE	cd/m <sup>2</sup>		45	56	--
UNIFORMITY	400Hz,100Vrms SINE WAVE	%		85	90	--
CURRENT CONSUMPTION	400Hz,100Vrms SINE WAVE	mA/cm <sup>2</sup>		--	0.12	0.17
CHROMATICITY	400Hz,100Vrms SINE WAVE	BLUE GREEN	X	0.15	0.17	0.19
			Y	0.33	0.35	0.37
		White	X	0.30	0.32	0.34
			Y	0.34	0.36	0.38

Note: Measured at the EL panel unit .

## 7. TIMING CHARACTERISTICS

### Segment timing:

Item	Symbol	Condition	Min.	Typ.	Max.	Units
Shift Clock Period *1	TWCK	$T_R, T_F \leq 10\text{ns}$	125			ns
Shift Clock Pulse Width	TWCKH TWCKL		51			ns
Data Set Up Time	TDS		30			ns
Data Hold Time	TDH		40			ns
Latch Pulse "H" Pulse Width	TWLPH		51			ns
Shift Clock Rise to Latch Pulse Rise Time	TLR		0			ns
Shift Clock Fall to Latch Pulse Fall Time	TSL		51			ns
Latch Pulse Rise to Shift Clock Rise Time	TLR		51			ns
Latch Pulse Fall to Shift Clock Fall Time	TLH		51			ns
Input Signal Rise/ Fall Time *2	$T_R, T_F$				50	ns
Enable Setup Time	TS		36			ns
DISPOFFB Removal Time	TSD		100			ns
DISPOFFB "L" Pulse Width	TWDL		1.2			u
Output Delay Time (1)	TD	$C_L=15\text{pF}$			78	ns
Output Delay Time (2)	TPD1, TPD2	$C_L=15\text{pF}$			1.2	us
Output Delay Time (3)	TPD3	$C_L=15\text{pF}$			1.2	us

Note: \*1. Take the cascade connection into consideration.

\*2.  $(T_{WCK} - T_{WCKH} - T_{WCKL})/2$  is maximum in the case of high speed operation.



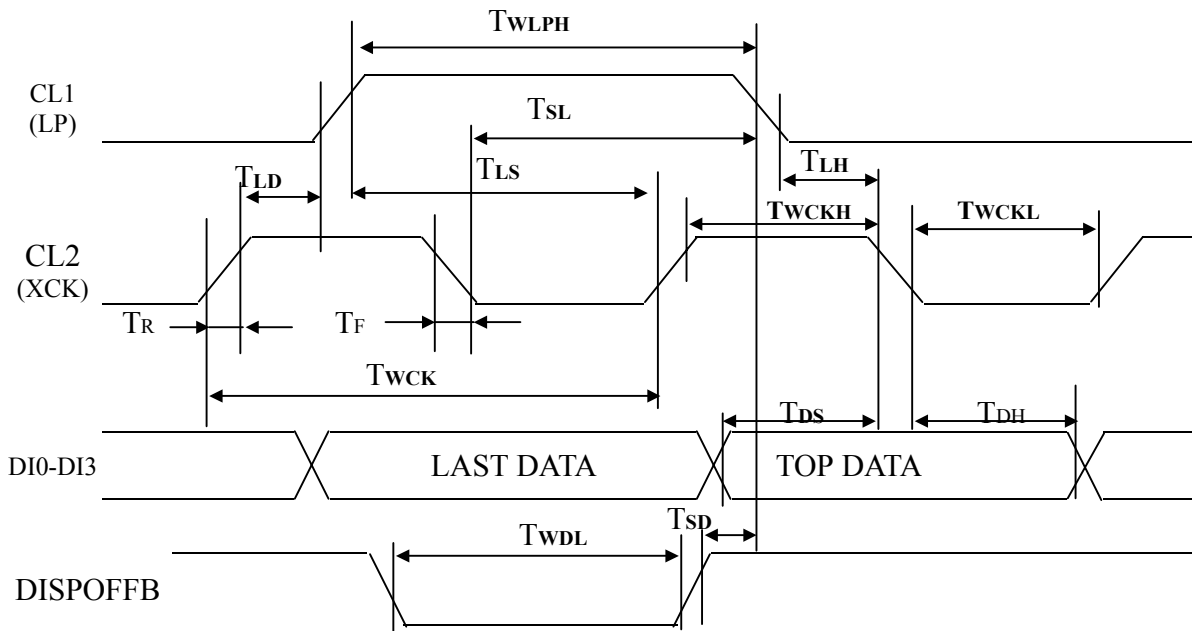

### SEGMENT TIMING

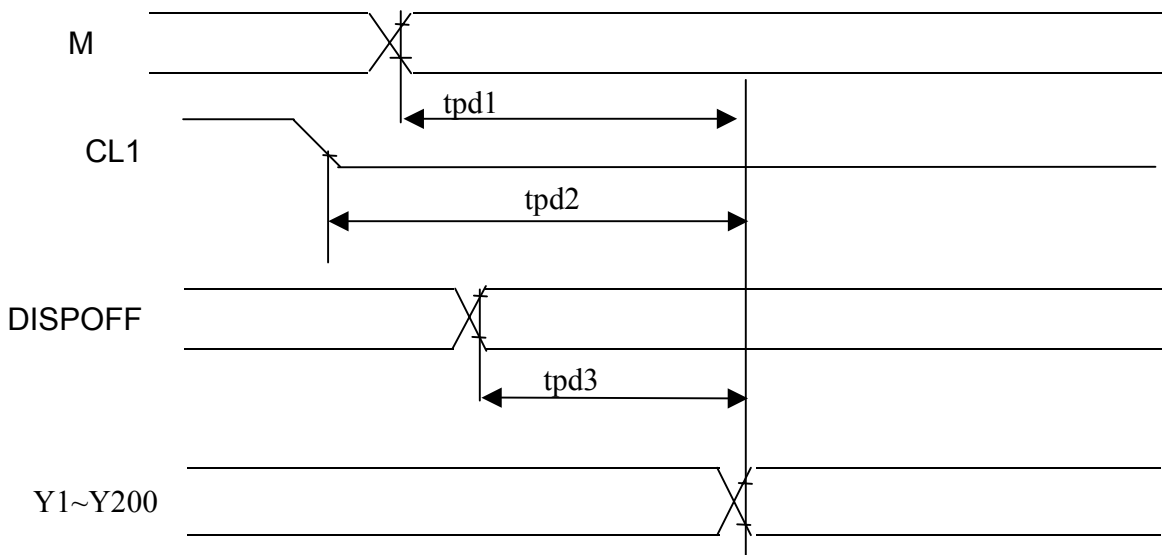

**common timing:**

Item	Symbol	Condition	Min.	Typ.	Max.	Units
Shift Clock Period	T <sub>WLP</sub>	T <sub>R</sub> , T <sub>F</sub> ≤ 20ns	250			ns
Pulse “H” Pulse Width	T <sub>WLPH</sub>	VDD = +5.0V ± 10%	15			ns
		VDD = +2.5V ~ +4.5V	30			
Data Set Up Time	T <sub>SU</sub>		30			ns
Data Hold Time	T <sub>H</sub>		50			ns
Input Signal Rise/ Fall Time	T <sub>R</sub> , T <sub>F</sub>				50	ns
DISPOFFB Removal Time	T <sub>SD</sub>		100			ns
DISPOFFB “L” Pulse Width	T <sub>WDL</sub>		1.2			u
Output Delay Time (1)	T <sub>DL</sub>	CL = 15pF			200	ns
Output Delay Time (2)	T <sub>PD1</sub> , T <sub>PD2</sub>	CL = 15pF			1.2	us
Output Delay Time (3)	T <sub>PD3</sub>	CL = 15pF			1.2	us

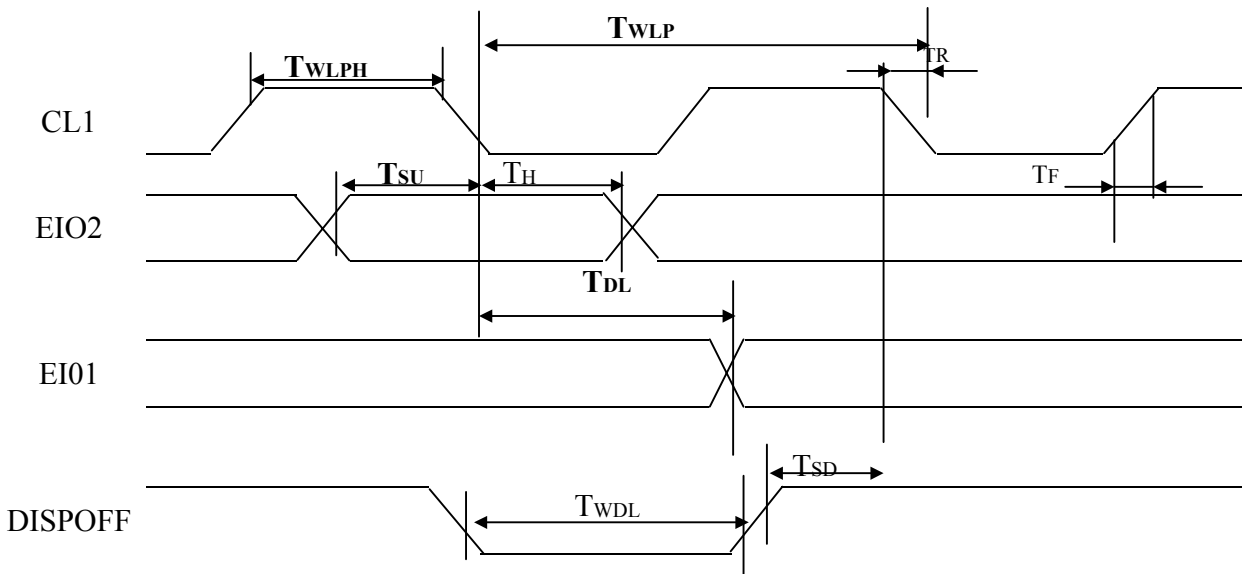

**COMMON TIMING**

## 7.1 TIMING CHART

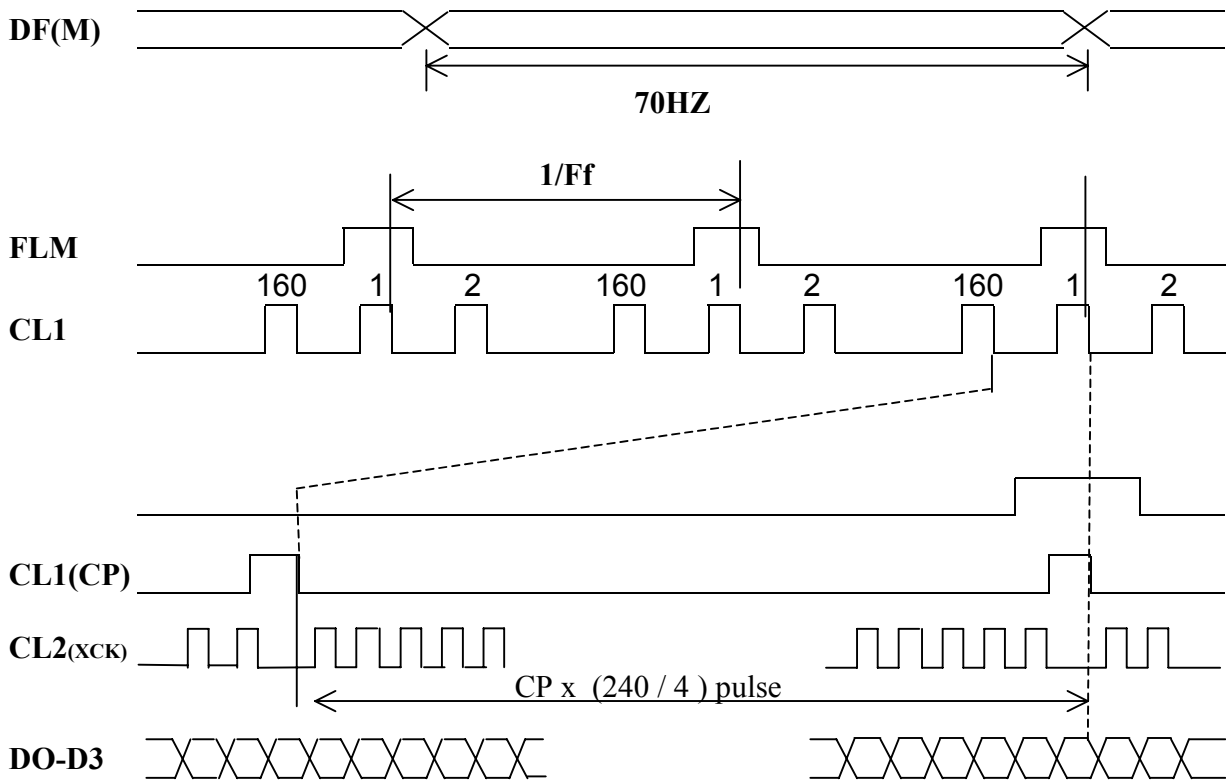

## 7.2 S-8330 Timing

common timing:

Item	Symbol	Condition	Min.	Typ.	Max.	Units
Output Voltage range	VOUT	S-8330A24	12	-	24	V
Potential division accuracy			-	-	±2.4	%
Electric volume resolution			-	1/256	-	
Error in linearity			-	-	±1/2	LSB
Data setup time	tsc		0.5	-	-	μs
Data hold time	thc		0.5	-	-	μs
VCLK falling edge to VSTRB rising edge	tss		0.5	-	-	μs
VSTRB pulse width	tda		0.5	-	-	μs
VSTRB falling edge to VCLK rising edge	ths		0.5	-	-	μs
VCLK pulse width	tdc		0.5	4.17	-	μs
VCLK period	ttc		5	8.33	-	μs
VDIN,VCLK,VSTRB input voltage “H” level	VSHC1	$V_{IN} \geq 3.0V$	2.4	-	-	V
	VSHC2	$V_{IN} \leq 3.0V$	1.6	-	-	
VDIN,VCLK,VSTRB input voltage “L” level	VSLC		-	-	0.2	
VDIN,VCLK,VSTRB input leakage current	ISLC	$V_{IN}=9V$	-1	-	1	μA

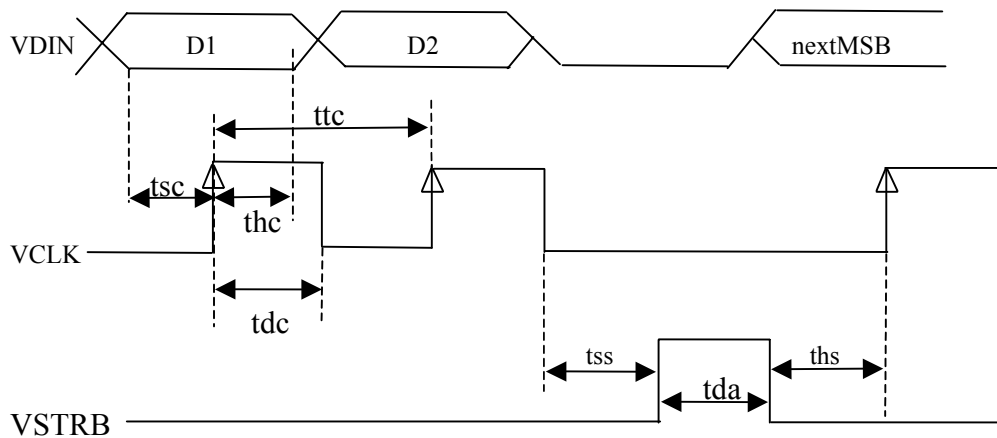

Data input Timing

Note 1: An electric volume has 8-bit resolution. However, its error in linearity may exceed  $\pm 1/2$ LSB only before and after switching from 127 to 128 (from 01111111 to 10000000) and vice versa. When the electric volume is used within the variable range of 12 V, its error in linearity corresponds to 6 bits ( $\pm 2.4\%$  potential division accuracy is ensured).

The S-8330/31 series incorporates an electric volume with an 8-bit shift register and an 8-bit latch. The output voltage is variable in the width of 12V. The output voltage can be held in the data transmission mode because the data read in the shift register is fetched into the latch by unsynchronized strobe input. Figure 1 shows a block diagram and timing charts

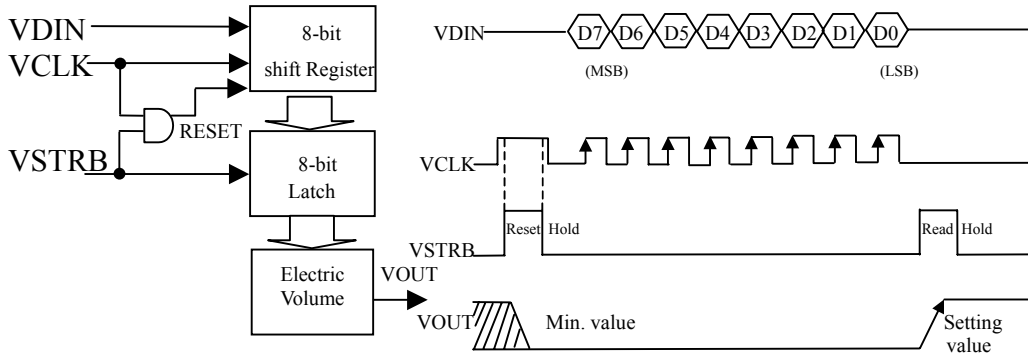

Figure 1 Block Diagram and Timing

**VDIN** :Inputs data to the electric volume. “Data 1” is input at “H” level; “Data 0” is input at “LOW” level.

**VCLK** :Inputs clock to the electric volume. Fetches data at VDIN pin into the shift register at the rising edge of clocks. When clocks of over 8 bits are input, the read data is shifted in succession for each clock, and data corresponding to 8 bits which was input lastly is valid.

**VSTRB** :Inputs strobe signal. The contents of the shift register are latched by turning the strobe signal to “H”. When the data fetched into the latch is directly transmitted to the electric volume, the output voltage changes. Data in the latch is held by turning the strobe signal to “L”.

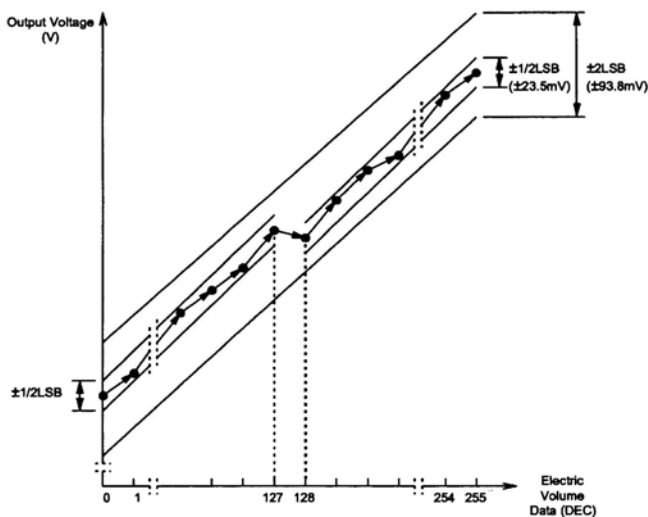

Figure 9 Linearity Accuracy

The electric volume has 8-bit resolution. An error in linearity may exceed  $\pm 1/2\text{LSB}$  ( $\pm 23.5\text{ mV}$ ) only before or after data changeover of  $127 \leftrightarrow 128$  ( $01111111 \leftrightarrow 10000000$ ) (see Figure 9).

The error in linearity corresponds to 6 bits ( $\pm 93.8\text{ mV}$ ) when used in the 12 V variable range.

In an application where the variable range of output voltage is 6 V or less, it is possible to use it with high linearity accuracy with appropriate product selection. For example, if you want to change output voltage within the range from 12 V to 18 V, select the S-8330A24FS and use it within the range of  $0 \leftrightarrow 127$  ( $00000000 \leftrightarrow 01111111$ ). If so, high linearity accuracy (within  $\pm 1/2\text{LSB}$ ) can be obtained.

## 8. PIN CONNECTIONS

No.	Symbol	Function
1	VDIN	S8330 serial data input.
2	VCLK	S8330 serial clock input.
3	VSTRB	S8330 strobe signal input.
4	VDD	Logic Power Input.
5	FLM	First line mark.
6	VSS	Ground, 0V
7	CL1	Data latch pulse.
8	VSS	Ground, 0V
9	M	Switch signal to convert LCD drive wave form into AC
10	/D-OFF	Display ON/ OFF control input (“H”=ON, “L”=OFF)
11	CL2	Data shift pulse.
12	NC	NO Connection.
13	NC	NO Connection.
14	D3	Input data signal 3.
15	D2	Input data signal 2.
16	D1	Input data signal 1.
17	D0	Input data signal 0.
18	EL-ON	EL Back light ON/OFF (“H”= OFF, “L”= ON)

## 9. POWER SUPPLY

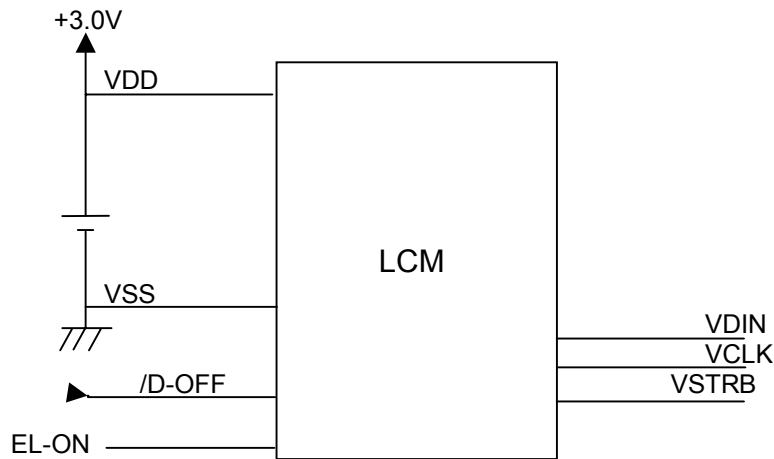

## 10. BLOCK DIAGRAM

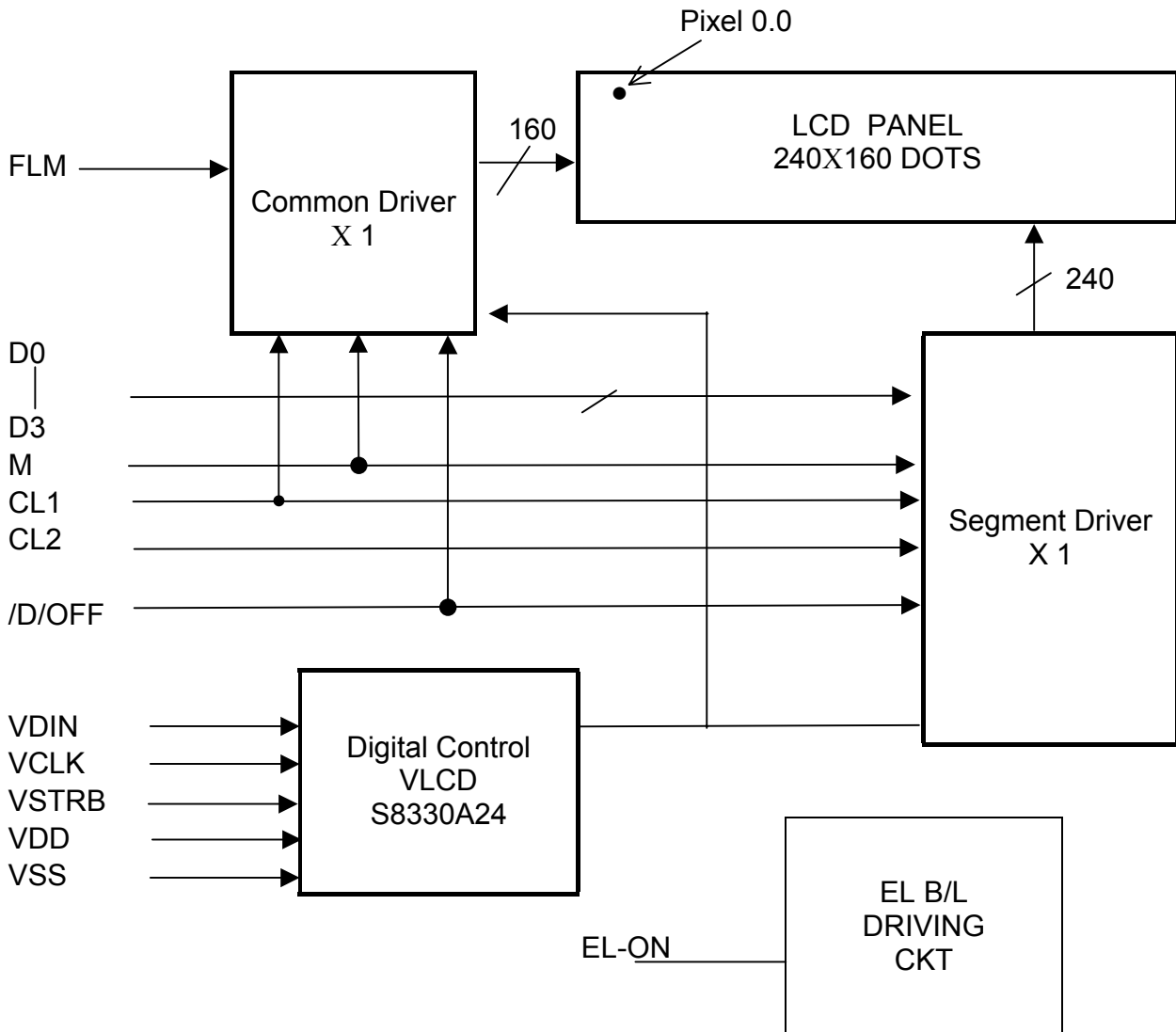

# 11. QUALITY ASSURANCE

## 11.1 Test Condition

### 11.1.1 Temperature and Humidity(Ambient Temperature)

Temperature :  $20 \pm 5^{\circ}\text{C}$

Humidity :  $65 \pm 5\%$

### 11.1.2 Operation

Unless specified otherwise, test will be conducted with LCM in operation.

### 11.1.3 Container

Unless specified otherwise, vibration test will be conducted on module only.

### 11.1.4 Test Frequency

Single cycle.

### 11.1.5 Test Method

No.	Parameter	Conditions	Regulations
1	High Temperature Operating	$70 \pm 2^{\circ}\text{C}$	Note 3
2	Low Temperature Operating	$-20 \pm 2^{\circ}\text{C}$	Note 3
3	High Temperature Storage	$80 \pm 2^{\circ}\text{C}$	Note 3
4	Low Temperature Storage	$-30 \pm 2^{\circ}\text{C}$	Note 3
5	Vibration Test (Non-operation state)	Total fixed amplitude : 1.5mm Vibration Frequency : 10 ~ 55Hz One cycle 60 seconds to 3 directions of X.Y.Z. for each 15 minutes	Note 3
6	Damp Proof Test (Non-operation state)	$40^{\circ}\text{C} \pm 2^{\circ}\text{C}$ , 90~95%RH, 96h	Note 1,2
7	Shock Test (Non-operation state)	To be measured after dropping from 60cm high once concrete surface in packing state	Note 3

Note 1: Returned under normal temperature and humidity for 4 hrs.

Note 2: No dew condensation to be observed.

Note 3: No change on display and in operation under the test condition



## 11.2 Inspection condition

### 11.2.1 Inspection conditions

The LCD shall be inspected under 40W white fluorescent light.

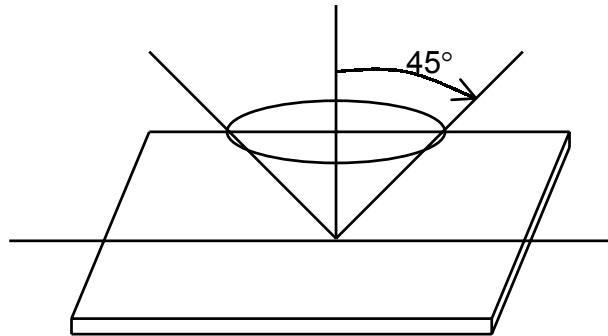

### 11.2.2 Definition of applicable Zones

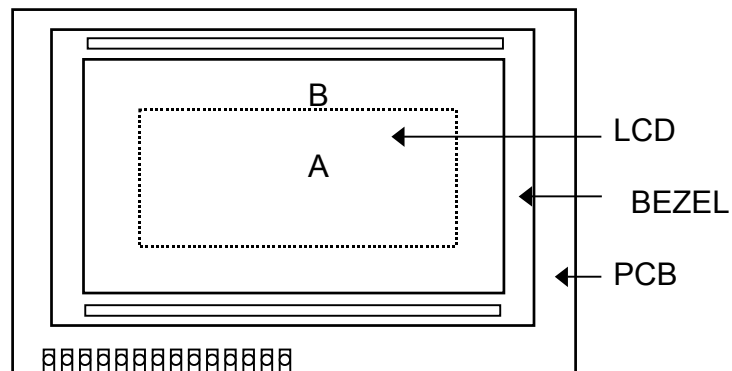

A : Display Area  
B : Non-Display Area

11.2.3 Inspection Parameters

No.	Parameter	Criteria																												
1	Black or White spots	<table border="1"> <thead> <tr> <th rowspan="2">Zone Dimension</th> <th colspan="2">Acceptable number</th> <th rowspan="2">Class Of Defects</th> <th rowspan="2">AQL Level</th> </tr> <tr> <th>A</th> <th>B</th> </tr> </thead> <tbody> <tr> <td>D &lt; 0.15</td> <td>*</td> <td>*</td> <td rowspan="4">Minor</td> <td rowspan="4">2.5</td> </tr> <tr> <td>0.15 ≤ D &lt; 0.2</td> <td>4</td> <td>4</td> </tr> <tr> <td>0.2 ≤ D ≤ 0.25</td> <td>2</td> <td>2</td> </tr> <tr> <td>D ≤ 0.3</td> <td>0</td> <td>1</td> </tr> </tbody> </table> <p>D = (Long + Short) / 2 * : Disregard</p>	Zone Dimension	Acceptable number		Class Of Defects	AQL Level	A	B	D < 0.15	*	*	Minor	2.5	0.15 ≤ D < 0.2	4	4	0.2 ≤ D ≤ 0.25	2	2	D ≤ 0.3	0	1							
Zone Dimension	Acceptable number			Class Of Defects	AQL Level																									
	A	B																												
D < 0.15	*	*	Minor	2.5																										
0.15 ≤ D < 0.2	4	4																												
0.2 ≤ D ≤ 0.25	2	2																												
D ≤ 0.3	0	1																												
2	Scratch, Substances	<table border="1"> <thead> <tr> <th colspan="2">Zone</th> <th colspan="2">Acceptable number</th> <th rowspan="2">Class Of Defects</th> <th rowspan="2">AQL Level</th> </tr> <tr> <th>X (mm)</th> <th>Y (mm)</th> <th>A</th> <th>B</th> </tr> </thead> <tbody> <tr> <td>*</td> <td>0.04 ≥ W</td> <td>*</td> <td>*</td> <td rowspan="4">Minor</td> <td rowspan="4">2.5</td> </tr> <tr> <td>3.0 ≥ L</td> <td>0.06 ≥ W</td> <td>4</td> <td>4</td> </tr> <tr> <td>2.0 ≥ L</td> <td>0.08 ≥ W</td> <td>2</td> <td>3</td> </tr> <tr> <td>—</td> <td>0.1 &lt; W</td> <td>0</td> <td>1</td> </tr> </tbody> </table> <p>X : Length Y : Width * : Disregard Total defects should not exceed 4/module</p>	Zone		Acceptable number		Class Of Defects	AQL Level	X (mm)	Y (mm)	A	B	*	0.04 ≥ W	*	*	Minor	2.5	3.0 ≥ L	0.06 ≥ W	4	4	2.0 ≥ L	0.08 ≥ W	2	3	—	0.1 < W	0	1
Zone		Acceptable number		Class Of Defects	AQL Level																									
X (mm)	Y (mm)	A	B																											
*	0.04 ≥ W	*	*	Minor	2.5																									
3.0 ≥ L	0.06 ≥ W	4	4																											
2.0 ≥ L	0.08 ≥ W	2	3																											
—	0.1 < W	0	1																											
3	Air Bubbles (between glass & polarizer)	<table border="1"> <thead> <tr> <th rowspan="2">Zone Dimension</th> <th colspan="2">Acceptable number</th> <th rowspan="2">Class of Defects</th> <th rowspan="2">AQL Level</th> </tr> <tr> <th>A</th> <th>B</th> </tr> </thead> <tbody> <tr> <td>D ≤ 0.15</td> <td>*</td> <td>*</td> <td rowspan="3">Minor</td> <td rowspan="3">2.5</td> </tr> <tr> <td>0.15 &lt; D ≤ 0.25</td> <td>2</td> <td>*</td> </tr> <tr> <td>0.25 &lt; D</td> <td>0</td> <td>1</td> </tr> </tbody> </table> <p>* : Disregard Total defects shall not excess 3/module.</p>	Zone Dimension	Acceptable number		Class of Defects	AQL Level	A	B	D ≤ 0.15	*	*	Minor	2.5	0.15 < D ≤ 0.25	2	*	0.25 < D	0	1										
Zone Dimension	Acceptable number			Class of Defects	AQL Level																									
	A	B																												
D ≤ 0.15	*	*	Minor	2.5																										
0.15 < D ≤ 0.25	2	*																												
0.25 < D	0	1																												
4	Uniformity of Pixel	<p>(1) Pixel shape (with Dent)</p>																												

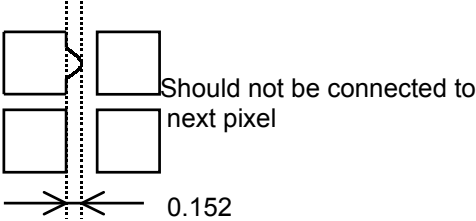
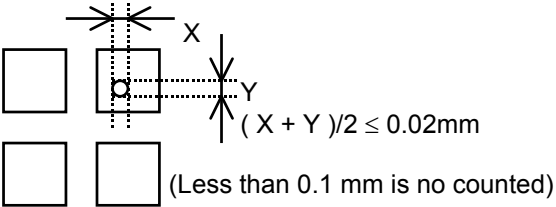
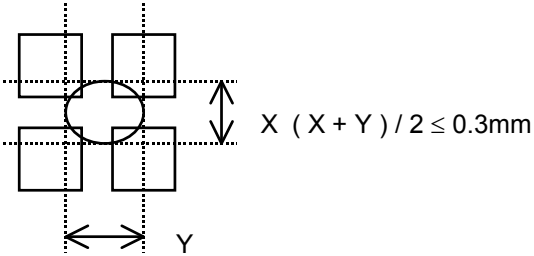
4	Uniformity of Pixel	<p>(2) Pixel shape ( with Projection)</p>  <p>(3) Pin hole</p>  <p>(4) Deformation</p>  <p>Total acceptable number : 1/pixel, 5/cell</p>	
		<b>Definition</b>	
Class of defects	<b>Major</b>	AQL 0.65%	It is a defect that is likely to result in failure or to reduce materially the usability of the product for the intended function.
		AQL 1.00%	It is a defect that is likely to assembly size and not result in functioning problem.
	<b>Minor</b>	AQL 2.5%	It is a defect that will not result in functioning problem with deviation classified.

### 11.3 Sampling Condition

Unless otherwise agree in written, the sampling inspection shall be applied to the incoming inspection of customer.

Lot size: Quantity of shipment lot per model.

Sampling type: normal inspection, single sampling

Inspection level: Level II

Sampling table: MIL-STD-105E

## 12. LOT NUMBERING SYSTEM

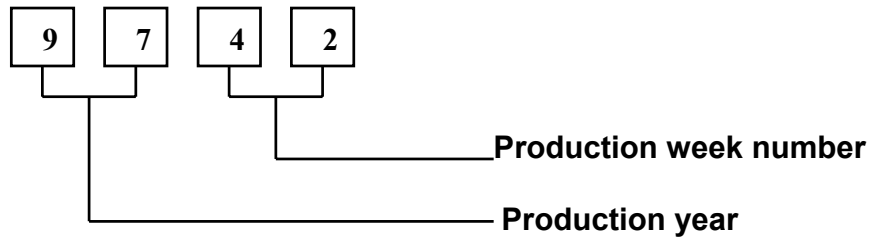

## 13. LCM NUMBERING SYSTEM

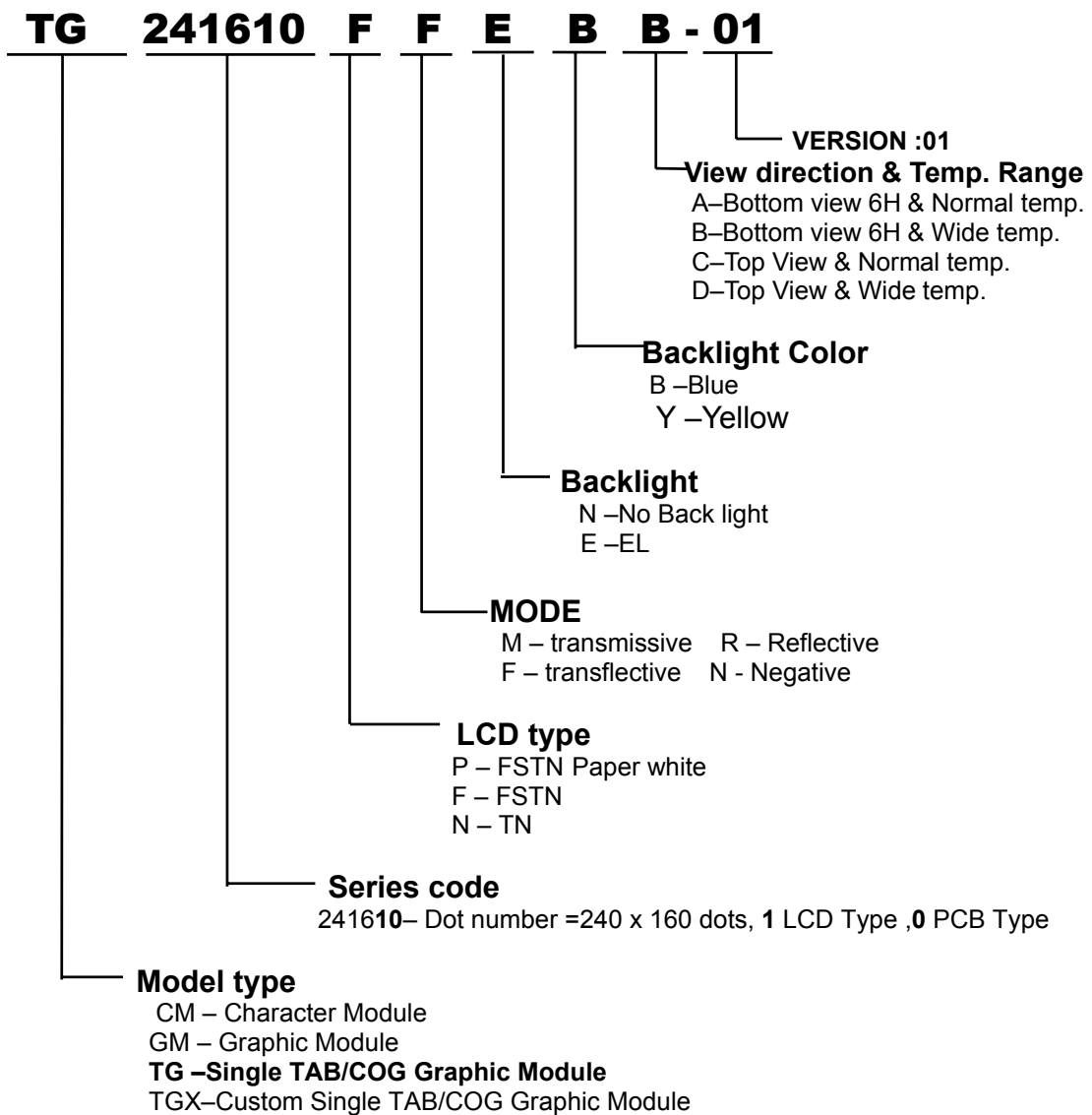

## 14. PRECAUTION FOR USING LCM

### 1. LIQUID CRYSTAL DISPLAY (LCD)

LCD is made up of glass, organic sealant, organic fluid, and polymer based polarizers. The following precautions should be taken when handling,

- (1). Keep the temperature within range of use and storage. Excessive temperature and humidity could cause polarization degradation, polarizer peel off or bubble.
- (2). Do not contact the exposed polarizers with anything harder than an HB pencil lead. To clean dust off the display surface, wipe gently with cotton, chamois or other soft material soaked in petroleum benzine.
- (3). Wipe off saliva or water drops immediately. Contact with water over a long period of time may cause polarizer deformation or color fading, while an active LCD with water condensation on its surface will cause corrosion of ITO electrodes.
- (4). Glass can be easily chipped or cracked from rough handling, especially at corners and edges.
- (5). Do not drive LCD with DC voltage.

### 2. Liquid Crystal Display Modules

#### 2.1 Mechanical Considerations

LCM are assembled and adjusted with a high degree of precision. Avoid excessive shocks and do not make any alterations or modifications. The following should be noted.

- (1). Do not tamper in any way with the tabs on the metal frame.
- (2). Do not modify the PCB by drilling extra holes, changing its outline, moving its components or modifying its pattern.
- (3). Do not touch the elastomer connector, especially insert an backlight panel (for example, EL).
- (4). When mounting a LCM make sure that the PCB is not under any stress such as bending or twisting. Elastomer contacts are very delicate and missing pixels could result from slight dislocation of any of the elements.
- (5). Avoid pressing on the metal bezel, otherwise the elastomer connector could be deformed and lose contact, resulting in missing pixels.

#### 2.2. Static Electricity

LCM contains CMOS LSI's and the same precaution for such devices should apply, namely

- (1). The operator should be grounded whenever he/she comes into contact with the module. Never touch any of the conductive parts such as the LSI pads, the copper leads on the PCB and the interface terminals with any parts of the human body.
- (2). The modules should be kept in antistatic bags or other containers resistant to static for storage.
- (3). Only properly grounded soldering irons should be used.
- (4). If an electric screwdriver is used, it should be well grounded and shielded from commutator sparks.

- (5) The normal static prevention measures should be observed for work clothes and working benches; for the latter conductive (rubber) mat is recommended.
- (6). Since dry air is inductive to statics, a relative humidity of 50-60% is recommended.

#### 2.3 Soldering

- (1). Solder only to the I/O terminals.
- (2). Use only soldering irons with proper grounding and no leakage.
- (3). Soldering temperature :  $280^{\circ}\text{C} \pm 10^{\circ}\text{C}$
- (4). Soldering time: 3 to 4 sec.
- (5). Use eutectic solder with resin flux fill.
- (6). If flux is used, the LCD surface should be covered to avoid flux spatters. Flux residue should be removed afterwards.

#### 2.4 Operation

- (1). The viewing angle can be adjusted by varying the LCD driving voltage V<sub>0</sub>.
- (2). Driving voltage should be kept within specified range; excess voltage shortens display life.
- (3). Response time increases with decrease in temperature.
- (4). Display may turn black or dark blue at temperatures above its operational range; this is (however not pressing on the viewing area) may cause the segments to appear "fractured".
- (5). Mechanical disturbance during operation (such as pressing on the viewing area) may cause the segments to appear "fractured".

#### 2.5 Storage

If any fluid leaks out of a damaged glass cell, wash off any human part that comes into contact with soap and water. Never swallow the fluid. The toxicity is extremely low but caution should be exercised at all the time.

#### 2.6 Limited Warranty

Unless otherwise agreed between DATA IMAGE and customer, DATA IMAGE will replace or repair any of its LCD and LCM which is found to be defective electrically and visually when inspected in accordance with DATA IMAGE acceptance standards, for a period on one year from date of shipment. Confirmation of such date shall be based on freight documents. The warranty liability of DATA IMAGE is limited to repair and/or replacement on the terms set forth above. DATA IMAGE will not be responsible for any subsequent or consequential events.

# 15. OUTLINE DRAWING

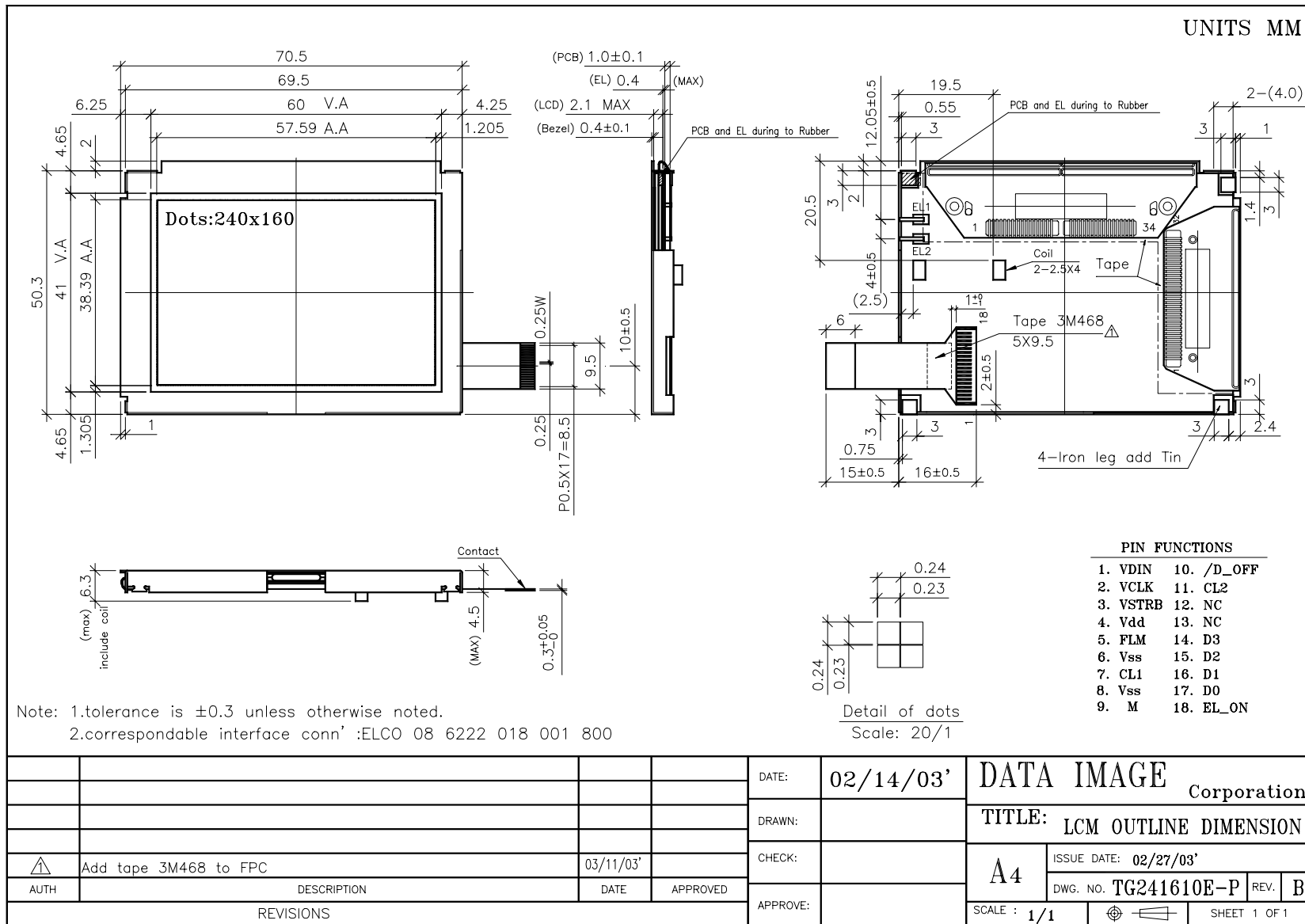

## 16. PACKAGE INFORMATION

