

LSI/CSI

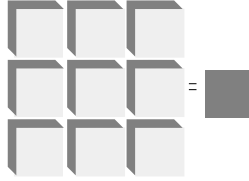

LS7540



LSI Computer Systems, Inc. 1235 Walt Whitman Road, Melville, NY 11747 (631) 271-0400 FAX (631) 271-0405

TOUCH CONTROL CONTINUOUS DIMMER with AUTOMATIC GAIN CONTROL (AGC)

June 2006

FEATURES:

- Touch or pushbutton control of incandescent lamps.
- Touch Sensitivity guaranteed to 600pF Touch Plate Capacitance.
- Touch Operation independent of line plug polarity.
- Minimal external components.
- AGC Loop stabilizes immediately after Power-Up.
- Brightness state is Off after AC power applied.
- No change of Brightness state if AC power interrupted < 0.5 sec
- Advanced CMOS design for reliable operating characteristics and low power.
- 50/60 Hz Line Frequency.
- 5V Operation (V_{DD} - V_{SS}).
- LS7540 (DIP); LS7540-S (SOIC) - See Figure 1 -

APPLICATIONS:

- Screw-in and built-in adapter modules for converting table and floor lamps to touch control for continuous dimming.

DESCRIPTION:

The LS7540 is a CMOS integrated circuit for controlling the brightness of incandescent lamps with momentary touch. When its TOUCH input is connected to a lamp body, the entire lamp turns into a touch plate. A built-in AGC circuit allows for a wide range of lamp sizes to be used, ranging from very small table lamps to very large floor lamps. The brightness is controlled by controlling the conduction angle of a triac in series with the lamp and triggered by the TRIG/ output. Between off and maximum, there are 124 steps of brightness levels, level zero being off and level 124 being maximum. The phase reference of the Trig/ signal with respect to the AC line is maintained through the SYNC input.

Touch Operation

The on/off and brightness control of the lamp is made with brief touches of the lamp body as described below:

- In the off state a single touch will turn the lamp to full_on.
- At full-on a single touch will start a dim-cycle causing the brightness to diminish gradually until the lamp turns off.
- During a dim-cycle a single touch will stop the dim-cycle and lock in the brightness present at that time. Another touch will restart the dim-cycle from the present brightness causing the brightness to ramp down towards off again. The start and stop of dim-cycle can be repeated over and over again until the lamp turns off.

INPUT/OUTPUT DESCRIPTION:

CLOCK Input (Pin 1)

An external resistor connected between this input and V_{DD}, along with an internal capacitor and oscillator stage, generates a clock which is used for all timing functions. The recommended value of this resistor for 50Hz and 60Hz operation is specified in the ELECTRICAL CHARACTERISTICS.

PIN ASSIGNMENT TOP VIEW

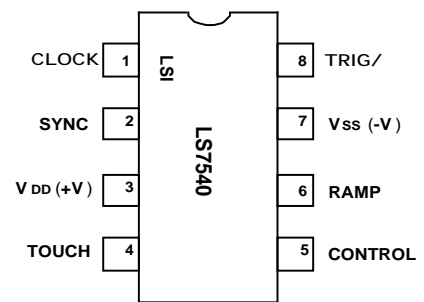

FIGURE 1

SYNC Input (Pin 2)

50Hz or 60Hz AC input for zero crossing detection.

V_{DD} (Pin 3) Supply voltage positive terminal.

TOUCH Input (Pin 4)

Input for sensing that a touch has been made on a lamp surface or other touch plate. This action alters the state of the TRIG/ output as described in the Touch Operation section of the General Description.

CONTROL I/O (Pin 5)

An external R-C network connected between this pin and V_{DD} establishes the controlling feedback for the AGC Loop.

RAMP Input/Output (Pin 6)

The ramp down rate of the brightness in the dimming cycle is regulated by a resistor-capacitor (RC) pair connected to the RAMP input. The ramp rate is equal to 4TRC per step, where TRC = 0.48RC. Total ramp down time (T_T) from maximum brightness to off is equal to 496TRC.

Example: R = 200k , C = 0.22uF;
TRC = 0.48 x (200x10³) x (0.22x10⁻⁶) = 0.02 sec.
Ramp rate = 4 x TRC = 0.08 sec/step;
Total ramp time, T_T = 496 x TRC = 9.92 sec.

V_{SS} (Pin 7) Supply voltage negative terminal.

TRIG/ output (Pin 8)

The TRIG/ output produces a negative pulse every half cycle of the AC line period to turn on a triac in series with the lamp or any other load device. The brightness of the lamp is regulated by regulating the conduction angle, Ø (See Fig. 2) of the TRIG/ signal. The conduction angles at maximum brightness (level 124) and minimum brightness (level 1) are 162° and 50° with 0.91° incremental steps.

ABSOLUTE MAXIMUM RATINGS:

PARAMETER	SYMBOL	VALUE	UNIT
DC supply voltage	VDD - VSS	+6	V
Any input voltage	VIN	VSS - 0.3 to VDD + 0.3	V
Operating temperature	TA	-20 to +85	°C
Storage temperature	TSTG	-65 to +150	°C

ELECTRICAL AND TRANSIENT CHARACTERISTICS:

(All voltages referenced to VSS. TA = +25°C unless otherwise specified.)

PARAMETER	SYMBOL	MIN	TYP	MAX	UNIT	CONDITIONS
Supply Voltage	VDD	+4.5	5.0	+5.5	V	-
Supply Current	IDD	-	-	500	uA	Output off, VDD = +5.0V
TRIG/ Sink Current Vo = VDD - 3V	Io	-50	-	-	mA	VDD = +5.0V
TRIG/ Source Current Vo = VDD - 0.2V	Io	+0.1	-	-	mA	VDD = +5.0V
TRIG/ Pulse Width	Tw	-	105	-	µsec	RC = 300k , 60Hz
	-	-	126	-	µsec	RC = 360k , 50Hz
CLOCK Resistor	-	-	350	-	k	60Hz
	-	-	420	-	k	50Hz
CONTROL Resistor	-	-	10	-	M	-
CONTROL Capacitor	-	-	1	-	µF	-
Touch Plate Capacitance	-	-	-	600	pF	-
Touch Duration	Ts	67	-	-	ms	60Hz
	Ts	80	-	-	ms	50Hz
Conduction Angle	Ø	50	-	162	deg	-
Ø incremental steps (Note 1)	Ø	-	0.91	-	deg	-
RAMP Resistor	R	2	-	no limit	k	-
RAMP Capacitor	C	200	-	no limit	pF	-
RAMP RC	TRC	25	-	no limit	µs	60Hz
RAMP RC	TRC	30	-	no limit	µs	50Hz
RAMP Rate	-	-	4TRC	-	sec/step	-
Max to off slew time	Tt	-	496TRC	-	sec	-

Note 1: Total number of steps = 124.

FIGURE 2. TRIG/ OUTPUT CONDUCTION ANGLE, \emptyset

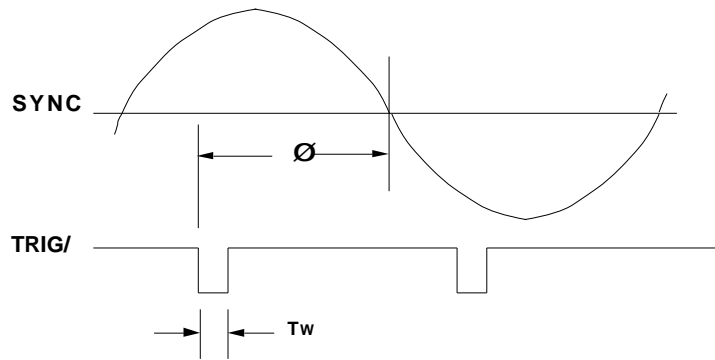

The information included herein is believed to be accurate and reliable. However, LSI Computer Systems, Inc. assumes no responsibilities for inaccuracies, nor for any infringements of patent rights of others which may result from its use.

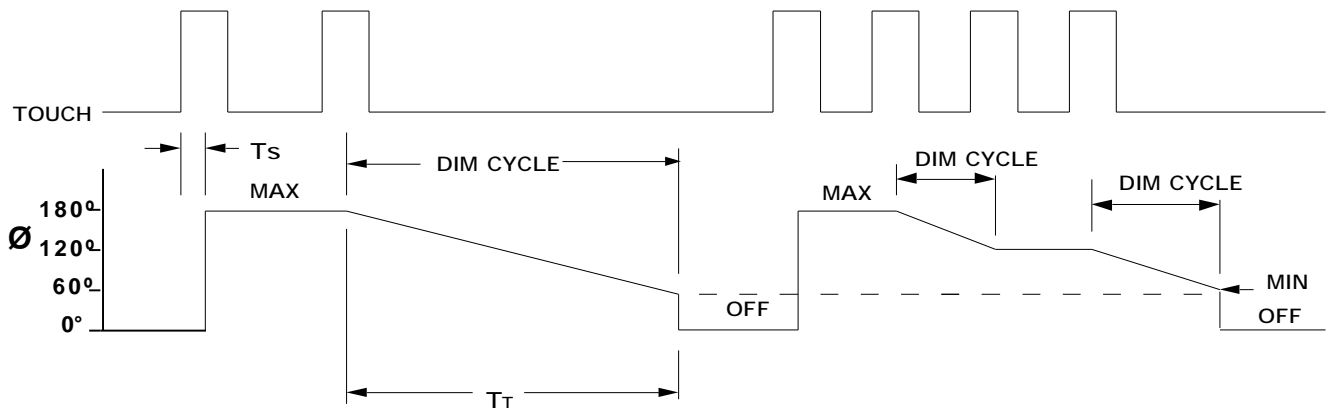

FIGURE 3. TOUCH vs TRIG/ CONDUCTION ANGLE, \emptyset

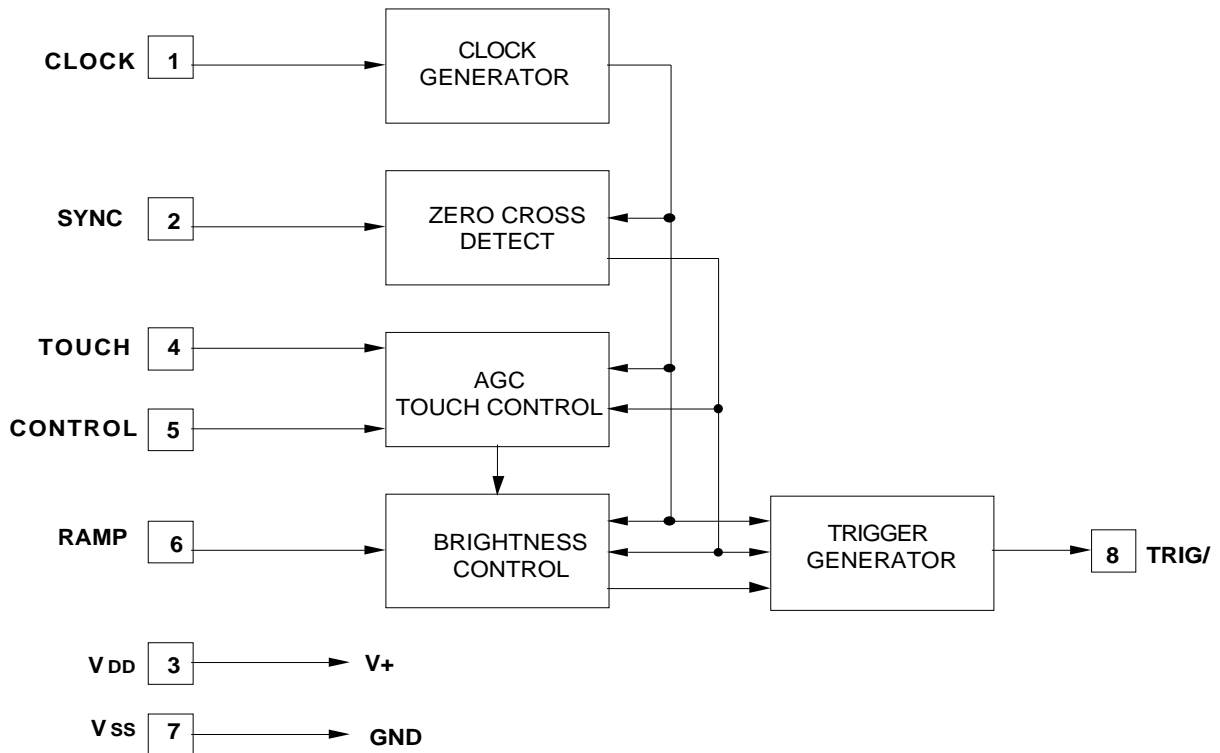
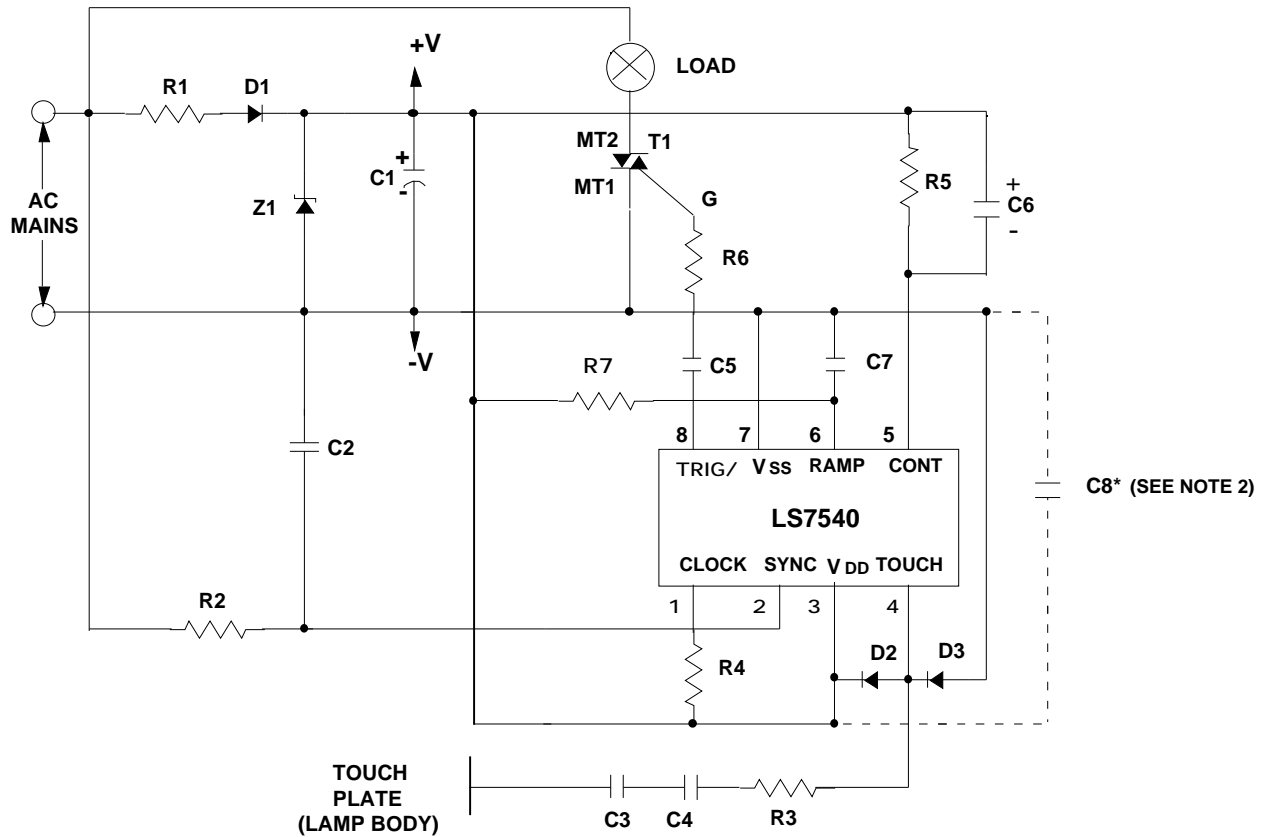

FIGURE 4. LS7540 BLOCK DIAGRAM

FIGURE 5. TOUCH LAMP APPLICATION SCHEMATIC #1



115VAC APPLICATION

- | | |
|--------------------------|--------------------------------------|
| R1 = 20k , 1W | C4 = 1000pF, 1kV |
| R2 = 470k , 1/4W | C5 = 0.03µF, 16V (only for Figure 5) |
| R3 = 1k , 1/4W | C6 = 1µF, 16V |
| (1) R4 = 350k , 1/4W, 1% | C7 = See Note 1 |
| R5 = 10M , 1/4W | Z1 = 5.1V, 1/4W Zener |
| R6 = 100 , 1/4W | D1 = 1N4004 |
| R7 = See Note 1 | D2 = 1N4148 |
| C1 = 47µF, 16V | D3 = 1N4148 |
| C2 = 1000pF, 16V | T1 = Q2004L4 (Typical Triac) |
| C3 = 1000pF, 1kV | or Q2004F41 (Typical Triac) |

220VAC APPLICATION

- | |
|------------------------------|
| R1 = 39k , 2W |
| R2 = 910k , 1/4W |
| (1) R4 = 420k , 1/4W, 1% |
| D1 = 1N4005 |
| T1 = Q4004L4 (Typical Triac) |
| or Q4004F41 (Typical Triac) |
- All other values remain the same.

(1) Resistor should be placed adjacent to Pin 1.

NOTE 1: See RAMP input description for determining values for R7 and C7.

NOTE 2: A good PCB layout using through-hole components will provide protection for ESD introduced at the Touch Plate in the range of 25kV. Using surface mount components and/or a poor PCB layout can reduce the ESD protection. The OEM can increase the ESD protection provided by the product with any combination of the following steps:

Step 1: The most effective and least costly way to increase ESD protection is to create a spark gap around the Touch Plate input on the PCB. This will increase ESD protection on a good PCB layout to about 35kV. The gap should be made with a split metal ring with each side of the metal ring connected back to opposite sides of the AC line. This ensures that a path for the spark back to house ground through AC Neutral exists independent of line plug polarity. The split ring and the center conduction plate should be constructed so that the spacing between them conforms to UL requirements. The spark gap will absorb most of the ESD leaving a remnant of about 10kV for the rest of the circuit to absorb.

Step 2: Increase R3 from 1k to 5.1k and add C8, a 0.1µF capacitor, between VDD and Vss. (A minimal loss in touch sensitivity may be experienced.)

Step 3: Replace diodes D2 and D3 (1N4148) with Schottky diodes (1N5819 or similar)

FIGURE 6. TOUCH LAMP APPLICATION SCHEMATIC #2

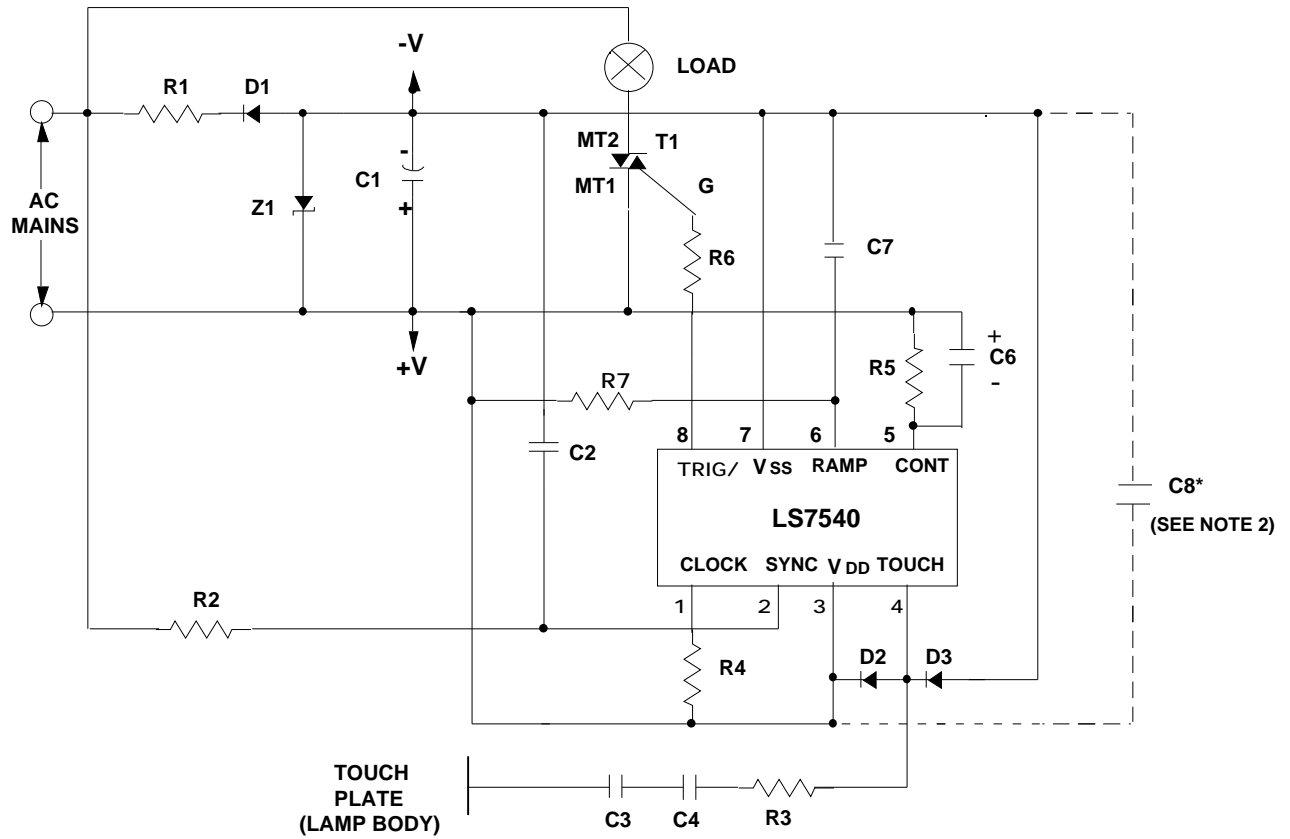

The Figure 6 Application Schematic functions identically to that shown in Figure 5 with one less component. Referencing Triac T1 to the +V power supply of the IC eliminates the need to AC couple the TRIAC/ pulse to the Triac Gate thereby eliminating component C5.