



RabbitNet™ RN1100

Digital I/O Expansion Card
\$73 (qty. 100)

The RabbitNet RN1100 Digital I/O card is the first in a series of peripheral I/O cards designed for use with Z-World controller products with RabbitNet expansion ports, such as the BL2500 Coyote and OP7200 eDisplay. The cards are DIN rail mountable and have friction-lock connectors for simplified OEM manufacturability.

RabbitNet

The RabbitNet expansion ports enable a modular and expandable embedded control system whose configuration of I/O cards can be tailored to a large variety of demanding real-time control, display, and data-acquisition applications. A typical RabbitNet system consists of a master single-board computer and one or more peripheral I/O cards. A high-performance Rabbit 3000® or Rabbit 2000® microprocessor on the master provides fast data processing, and the BL2500 master also provides the DCIN and +5 V power for the peripheral boards.

Programming RabbitNet Cards

Programs are developed and debugged using Z-World's industry-proven Dynamic C® software, which runs on a Windows PC. The Digital I/O Board is a slave; the master to which RabbitNet boards are connected is programmed using version 8.01 or later of Z-World's Dynamic C.

Dynamic C includes comprehensive debugging support and includes break points, watch expressions and many other extensive features oriented toward real-time embedded systems programming. An extensive library of drivers and sample programs is provided, including a royalty-free TCP/IP stack for network and Internet communications. Full source code is provided for most library routines. Dynamic C is sold separately.

Connectivity Tools

Z-World offers a connectivity kit for wiring assemblies that interface with the friction-lock connectors on the digital I/O board.

- **Hardware Features**

- 24 protected and filtered digital inputs
- 16 high-speed protected sinking/sourcing digital outputs
- Four 10-bit analog input channels
- 100 mm DIN rail tray mountable
- RabbitNet interface: 1 Megabit per second using standard Ethernet cable, up to 10 m (33 ft) away from master (RS-422)

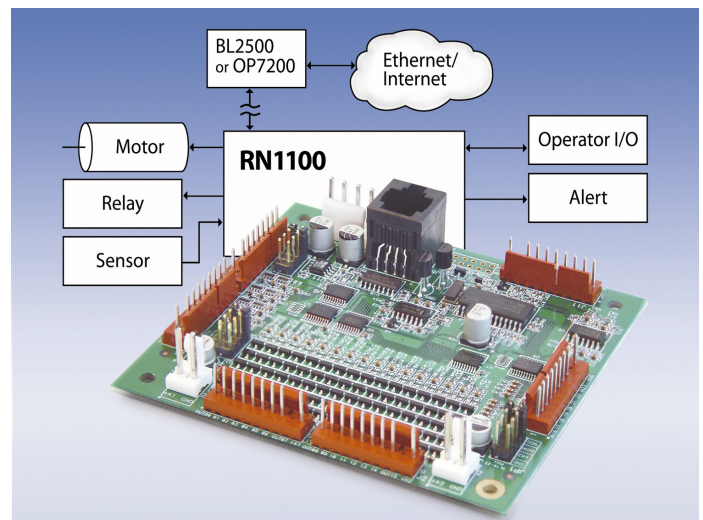

RN1100 Digital I/O Expansion Specifications & Features

FEATURE	RN1100
RabbitNet™ Serial Port	RS-422, 1 Mbits/s
Digital Inputs	24, protected to ±40 VDC, switching threshold is 1.5 V nominal
Digital Outputs	16, push-pull up to 200 mA each, 40 VDC max.
Analog Inputs	4 buffered channels: 10-bit resolution, 8-bit accuracy, sample rate: 1.5K samples/s, one channel Input ranges: 2 channels 0–10 V, single ended 1 channel 0–1 V, single-ended 1 channel -0.25–0.25 V differential Input resistance > 100K
Microprocessor	ST72F264G
Power	Vcc: +5 V DC, 20 mA DCIN: 9–32 V DC (12 V min. if using analog inputs), 500 mW +K1, +K2: 5-36 V DC, 1.6 A each
Operating Temp.	–40°C to +70°C
Humidity	5–95%, noncondensing
Connectors	Friction-lock connectors: <ul style="list-style-type: none"> • Six polarized 9-position terminals with 0.1" pitch • Two 2-position power terminals with 0.156" pitch • One 4-position terminal with 0.156" pitch • One RJ-45 RabbitNet™ jack
Board Size	3.55" × 3.95" × 0.67" (90 × 100 × 17 mm)
Pricing (qty. 1/100/1000)	\$89 / 73 / 63
Part Number	101-0612
Connectivity Kit	\$18
Part Number	101-0581

Connectivity Kit includes:

- | | |
|---|---|
| <ul style="list-style-type: none"> ▪ Six 1 x 10 friction-lock connectors (0.1" pitch) with sixty 0.1" crimp terminals ▪ Two 1 X 4 friction-lock connectors (0.156" pitch) | <ul style="list-style-type: none"> ▪ Two 1 x 2 friction-lock connectors (0.156" pitch) with fifteen 0.156" crimp terminals |
|---|---|

Each kit contains sufficient parts to interface with one Digital I/O Board (only fifty-four 0.1" crimp terminals and twelve 0.156" crimp terminals are actually used).

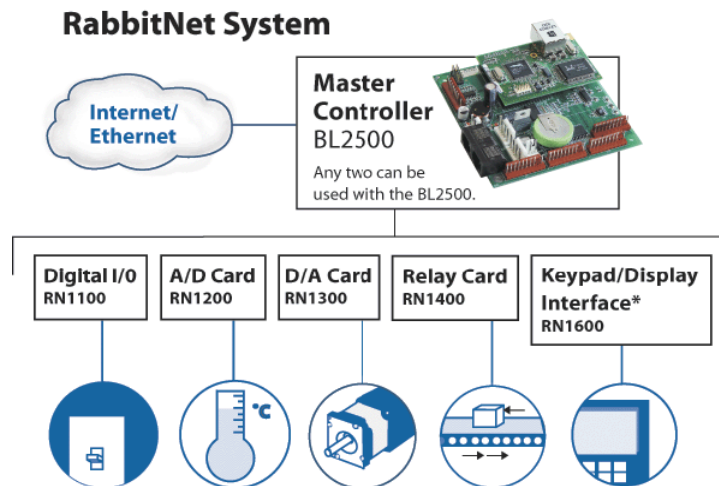

* Does not support two RN1600 cards on one BL2500