



Smoother running

Longer lasting

 Electronic contactors and motor controllers



Cl-tronic™

Product overview and selection guide

CI-tronic™ stands for high performance and long life

There are many ways to control a heating process or a motor, but you'll have a hard time finding a better way than with Danfoss CI-tronic™ components.

The CI-tronic concept represents a breakthrough in contactor technology. In effect, we've revolutionized the solid state relay to create a range of electronic contactors and motor controllers that are as simple to use as they are advanced. On the one hand, CI-tronic contactors are as easy to specify and install as ordinary electro-mechanical components. On the other, they provide the switching speed of a solid state relay, yet thanks to their unique design outlast conventional SSRs by a factor of 10.

The secret? At the heart of every CI-tronic component is a new power chip that eliminates the thermal problems which cause early burnouts in traditional SSRs. We call the technology "LTE," for low thermal expansion, but bottom line for you is significantly greater reliability and operational life.

Danfoss CI-tronic contactors are ideal for just about any type of industrial heating application, while CI-tronic motor controllers can be used on everything from conveyors to cranes.

Just as important, like all Danfoss controls, CI-tronic components come with our usual assurance of global availability, fair prices, volume supply and fast delivery. And, of course, responsive service, if needed.



A new standard across a whole product range

CI-tronic components set high standards for quality and reliability, but you'll also be impressed by the sheer scope of the product range. It includes both electronic contactors and analog power controllers as well as soft starters, torque limiters, reversing contactors and other types of motor controllers. Moreover, CI-tronic contactors already comply with IEC/EN 60947-4-3, the coming EU standard that will put tight new controls on ambient and operating temperatures and EMC immunity and emission.

Electronic contactors

ECI Electronic contactors
ACI Analogue power controllers

Motor controllers

MCI Motor controllers (soft starters)
MCI B MCI B soft starter with Brake
TCI Starting torque limiters
MCI DOL Motor contactors
RCI Reversing contactors

Table of contents

Introduction	2
Electronic contactors	4
Electronic contactors ECI-1	6
Electronic contactors ECI-2	8
Electronic contactors ECI-3	10
Analogue power controllers ACI	12
Motor controllers	14
Motor controllers MCI	16
Motor controllers with Brake MCI B	18
Starting torque limiters TCI	20
Motor contactors MCI DOL	22
Reversing contactors RCI	24
Common information	26

LTE technology takes the heat off our power chip

In conventional power relays, excessive heat generated by the power chip can lead to metal fatigue due to the different thermal expansion rates between the chip, the heat conductor and the current clip. In addition, air pockets in the soldering create hot spots on the chip, which can also impair performance and cause breakdowns. LTE technology solves the problem in a unique way to give you a high quality product with extremely long life:

- New materials virtually eliminate the effects of thermal expansion in the power chip
- New design with fewer soldering points increases heat dissipation
- New one-shot vacuum soldering process prevents the formation of air pockets and hot spots



The CI-tronics power chip consists of a silicon device soldered in a sandwich construction between a current clip and a heat conductor assembly. The chip allows current to flow when a control voltage is applied to the gate.

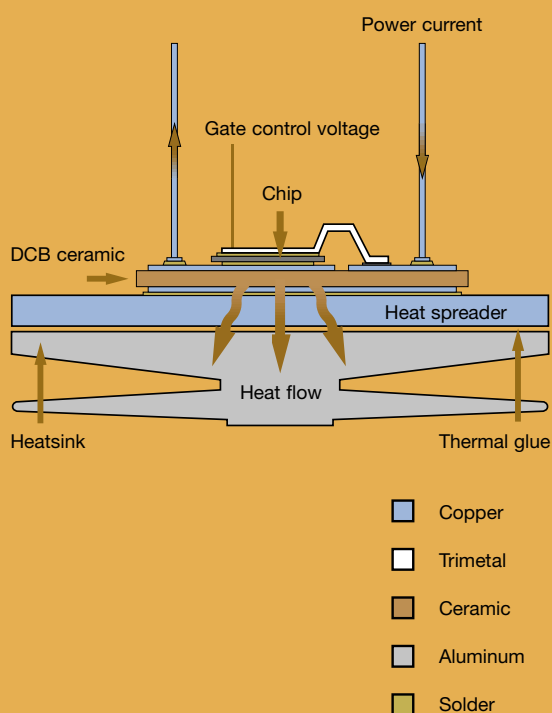

And they're as easy to specify and install as ordinary contactors

Contactors and motor controllers play a relatively small if crucial role in most processes, so why should choosing the right component be so complicated. You'll find CI-tronic components refreshingly easy to work with — as simple to specify and install as standard electro-mechanical devices and vastly easier to deal with than conventional SSRs. It only takes a moment to configure them, and there's no need for heat sinks or varistors. CI-tronic components can be dimensioned to their full rated power and are delivered as a completely engineered product featuring:

- Compact modular construction
- DIN-rail mountable design
- Industry standard ratings
- Universal control voltages
- LED status indicators
- Logical control settings



CI-tronic™ means fewer burnouts, better process control, longer heater life

It can happen to any OEM. You deliver a large and expensive system to a customer far from home. One day there's a breakdown and an urgent call for help. A service rep is dispatched to solve the problem only to find a burned out contactor in the heater system — a small fault but one that ends up costing you time, money, maybe even a little goodwill.

Whether you're producing equipment for injection molding, die casting, shrink wrapping or baking, constant operation eventually takes its toll on your heat control switch. Naturally, you can help avoid the unexpected by choosing contactors that are reliable. But you can also make contactor replacement an even rarer occurrence by equipping your system with CI-tronic™ components.

CI-tronic contactors are purpose-built for demanding industrial applications — or applications where you just don't want to risk that unexpected call in the night. With LTE technology, burnouts due to thermal stress become a very remote concern. CI-tronic contactors outlast solid state relays by a factor of 10 and outperform electro-mechanical contactors by an even wider margin. And they're price competitive, too.

CI-tronic products also gives you better control of your heating process and longer heater life. Control is improved by the use of faster switching patterns which provide more stable process temperatures, which in turn reduces thermal stress and extends heater life.

Electronic contactors

CI-tronic™

**CI-tronic contactors
outlast solid state relays
by a factor of 10**

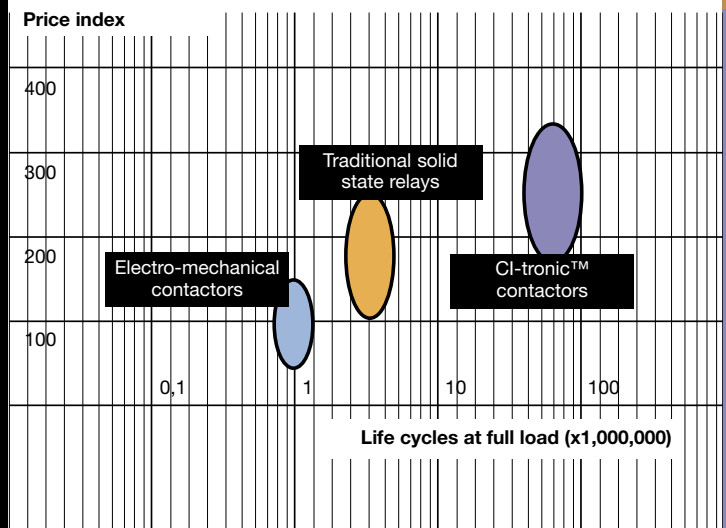



- << Accurate control of baking temperatures with CI-tronic components helps ensure a quality product.
- < Robust design makes CI-tronic contactors a wise choice for welding applications.



- < Soldering of sensitive electronic components requires the precise control provided by CI-tronic technology.
- > The dependability and long life of our components makes them ideal for heating applications in the plastics industry.



Electro-mechanical contactors

The low switching rates of electro-mechanical contactors cause wide temperature swings, resulting in poor process control and reduced heater life.

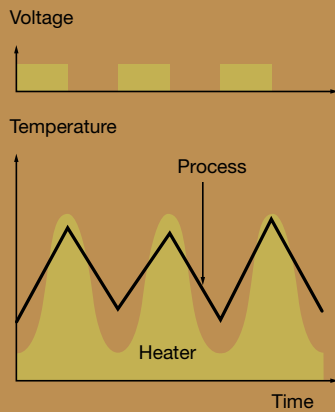

CI-tronic™ also simplifies purchasing and logistics

- Use CI-tronic components for a wide range of applications including electric heaters, infrared lamps, frequent switching valves, soft starting of transformers, welding machines and other equipment. They switch single and three-phase heaters up to 50 Amps.
- Use CI-tronic products worldwide. They're designed for line voltages up to 600 V a.c., feature a universal control voltage, and automatically adjust to 50/60 Hz operation.

Electronic contactors

CI-tronic contactors permit fast switching frequencies, giving you far better control of the heating process, fewer temperature fluctuations and reduced stress on the heater.

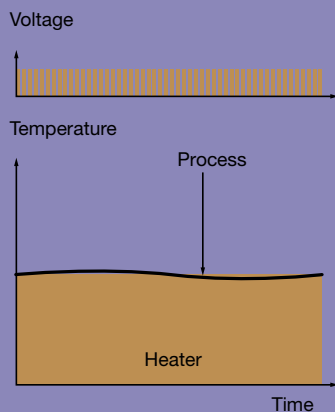

Single-phase electronic contactors Type ECI-1



Features

- SCR power chip with LTE technology
- Compact modular design complete with heat sink
- DIN-rail mountable
- Built-in varistor protection
- Operational current up to 50 A (AC-1)
- Line voltage up to 600 V a.c.
- Universal control voltage
- Burst firing (zero cross)
- LED status indicator
- IP 20 protection
- Problem-free specification according to industry standard
- Easy and quick installation

General

Type	ECI 15-1	ECI 30-1	ECI 50-1
Product description	ECI Electronic contactors are designed for applications demanding fast and precise switching. The contactors utilize SCR power chips with new LTE (Low Thermal Expansion) technology. This unique power chip design ensures high switching capacity and long life. The contactors are burst fired for reduced EMC emission, have LED status indicators and accept universal control voltages. The units are DIN-rail mountable, complete with heat sink and require no additional components.		
Typical applications	ECI electronic contactors are designed for fast and demanding switching of loads such as heaters, solenoids, transformers and motors		
Design standard	IEC/EN 60947-4-3		
Approvals	CE, CSA and NRTL/C		
Output specifications			
Operational current AC-1, AC-51 (heater load) AC-3, AC-53a (motor load)	15 A 15 A ¹	30 A 15 A	50 A 15 A
Operational voltage (50/60 Hz)	24-230 V a.c. 24-480 V a.c. 24-600 V a.c.		
Leakage current max.	1 mA		
Minimum operational current	10 mA		
Semiconductor protection fusing type 1 co-ordination type 2 co-ordination	50 A gL/gG 1800 A ² S ¹ (16 A gL/gG)	50 A gL/gG 1800 A ² S	50 A gL/gG 1800 A ² S
Thermal specifications and environment			
Power dissipation, continuous duty	1.2 W/A		
Power dissipation, intermittent duty	1.2 W/A × duty cycle		
Ambient temperature range	-5 to 40 °C		
Cooling method	Natural convection		
Mounting	Vertical (see also general mounting instructions)		
Max. ambient temperature with limited current	60 °C, see derating for high temperatures in chart below		
Storage temperature range	-20 to 80 °C		
Protection degree/pollution degree	IP 20/3		
Insulation specifications			
Rated insulation voltage, U _i	660 V		
Rated impulse withstand voltage, U _{imp}	4 kV		
Installation category	III		
Control specifications			
Control voltage (+/- 10%)	5-24 V d.c. / 24-230 V a.c./d.c.		
Pick-up voltage	4.25 V d.c. / 20.4 V a.c./d.c.		
Drop-out voltage	1.5 V d.c. / 7.2 V a.c./d.c.		
Control current/power max.	15 mA at 4 V d.c. / 1.5 VA/6 mA at 24 V d.c.		
Response time max.	1/2 cycle / 1 cycle		
EMC immunity	Meets requirements of EN 50082-1 and EN 50082-2		

1) Contactors designed for 600 V: Max. AC-3 load: 10 A Max. type 2 co-ordination fuse: 450 A²S

Selection guide

Operational voltage

Operational current max. AC-1	Control voltage	Dimensions	Type	Operational voltage		
				24-230 V a.c. Code no.	24-480 V a.c. Code no.	24-600 V a.c. Code no.
15 A	5-24 V d.c.	22.5 mm module	ECI 15-1	037N0063	037N0065	037N0067
15 A	24-230 V a.c./d.c.	22.5 mm module	ECI 15-1	037N0064	037N0066	037N0068
30 A	5-24 V d.c.	45 mm module	ECI 30-1	037N0007	037N0009	037N0011
30 A	24-230 V a.c./d.c.	45 mm module	ECI 30-1	037N0001	037N0003	037N0005
50 A	5-24 V d.c.	90 mm module	ECI 50-1	037N0008	037N0010	037N0012
50 A	24-230 V a.c./d.c.	90 mm module	ECI 50-1	037N0002	037N0004	037N0006

Wiring diagram

Heater load

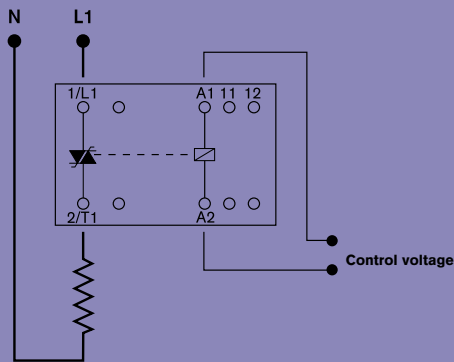

Wiring diagram

Motor load

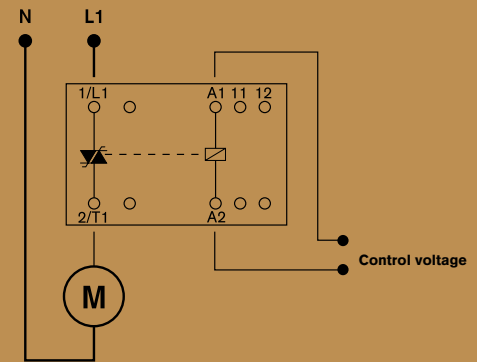

Functional diagram

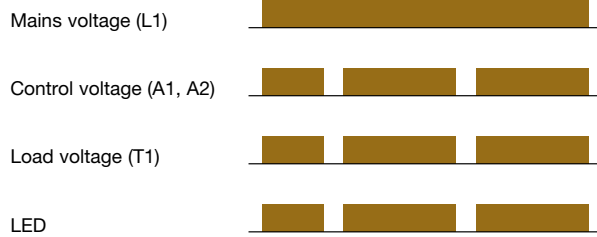

Operating at high temperatures

If the contactor is placed inside small cabinets, care must be taken to avoid exceeding the max. ambient temperature. Otherwise the current must be derated according to table.

For further information on dimensions, mounting and temperature overload protection see common information, page 26.

Ambient Temperature	ECI 15	ECI 30	ECI 50
40°C	15 A	30.0 A	50.0 A
50°C	12.5 A	25.0 A	40.0 A
60°C	10 A	20.0 A	30.0 A

Dual-phase electronic contactors Type ECI-2



Features

- SCR power chip with LTE technology
- Compact modular design complete with heat sink
- DIN-rail mountable
- Built-in varistor protection
- Operational current up to 50 A (AC-1)
- Line voltage up to 600 V a.c.
- Universal control voltage
- Burst firing (zero cross)
- LED status indicator
- IP 20 protection
- Problem-free specification according to industry standard
- Easy and quick installation



General

Type	ECI 30-2	ECI 50-2
Product description	ECI Electronic contactors are designed for applications demanding fast and precise switching. The contactors utilize SCR power chips with new LTE (Low Thermal Expansion) technology. This unique power chip design ensures high switching capacity and long life. The contactors are burst fired for reduced EMC emission, have LED status indicators and accept universal control voltages. The units are DIN-rail mountable, complete with heat sink and require no additional components.	
Typical applications	ECI electronic contactors are designed for fast and demanding switching of loads such as heaters, solenoids, transformers and motors	
Design standard	IEC/EN 60947-4-3	
Approvals	CE, CSA and NRTL/C	
Output specifications		
Operational current, AC-1, AC-51 (heater load) AC-3, AC-53a (motor load)	30 A accumulated 15 A accumulated	50 accumulated 15 accumulated
Operational voltage (50/60 Hz)	24-230 V a.c. 24-480 V a.c. 24-600 V a.c.	
Leakage current max.	1 mA	
Minimum operational current	10 mA	
Semiconductor protection fusing type 1 co-ordination type 2 co-ordination	50 A gL/gG 1800 A ² S	50 A gL/gG 1800 A ² S
Thermal specifications and environment		
Power dissipation, continuous duty	1.2 W/A (per phase)	
Power dissipation, intermittent duty	1.2 W/A × duty cycle (per phase)	
Ambient temperature range	-5 to 40°C	
Cooling method	Natural convection	
Mounting	Vertical (see also general mounting instructions)	
Max. ambient temperature with limited current	60°C, see derating for high temperatures in chart below	
Storage temperature range	-20 to 80°C	
Protection degree/pollution degree	IP 20/3	
Insulation specifications		
Rated insulation voltage, U _i	660 V	
Rated impulse withstand voltage, U _{imp}	4 kV	
Installation category	III	
Control specifications		
Control voltage (+/- 10%)	5-24 V d.c. / 24-230 V a.c./d.c.	
Pick-up voltage	4.25 V d.c. / 20.4 V a.c./d.c.	
Drop-out voltage	1.5 V d.c. / 7.2 V a.c./d.c.	
Control current/power max.	15 mA at 4 V d.c. / 1.5 VA/6 mA at 24 V d.c.	
Response time max.	1/2 cycle / 1 cycle	
EMC immunity	Meets requirements of EN 50082-1 and EN 50082-2	

Selection guide

Operational voltage

Operational current max. AC-1 ¹⁾	Control voltage	Dimensions	Type	Operational voltage		
				24-230 V a.c. Code no.	24-480 V a.c. Code no.	24-600 V a.c. Code no.
30 A	5-24 V d.c.	45 mm module	ECI 30-2	037N0019	037N0021	037N0023
30 A	24-230 V a.c./d.c.	45 mm module	ECI 30-2	037N0013	037N0015	037N0017
50 A	5-24 V d.c.	90 mm module	ECI 50-2	037N0020	037N0022	037N0024
50 A	24-230 V a.c./d.c.	90 mm module	ECI 50-2	037N0014	037N0016	037N0018

¹⁾ rated as the maximum sum of current in L1 and L2

Wiring diagram

2 Single-phase loads

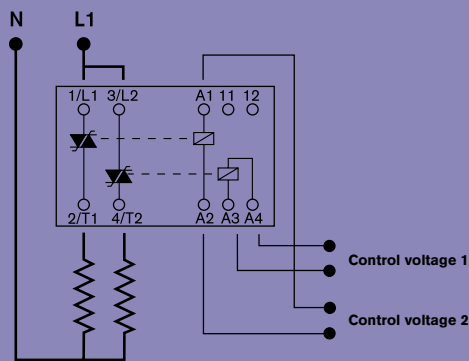

Wiring diagram

Three-phase load

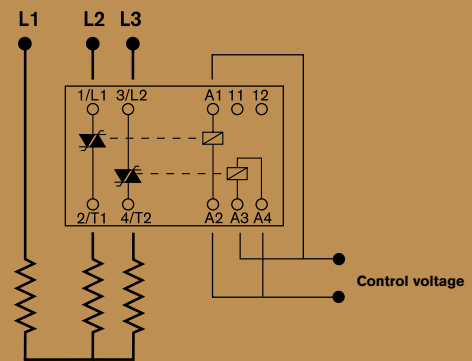

Functional diagram

Mains voltage (L1)



Mains voltage (L2)



Control voltage (A1, A2)



Control voltage (A3, A4)



Load voltage (T1)



Load voltage (T2)



LED 1



LED 2



Operating at high temperatures

If the contactor is placed inside small cabinets, care must be taken to avoid exceeding the max. ambient temperature. Otherwise the current must be derated according to table.

For further information on dimensions, mounting and temperature overload protection see common information, page 26.

Ambient Temperature	ECI 30	ECI 50
40°C	30.0 A	50.0 A
50°C	25.0 A	40.0 A
60°C	20.0 A	30.0 A

Three-phase electronic contactors Type ECI-3



Features

- SCR power chip with LTE technology
- Compact modular design complete with heat sink
- DIN-rail mountable
- Built-in varistor protection
- Operational current up to 20 A (AC-1)
- Line voltage up to 600 V a.c.
- Universal control voltage
- Burst firing (zero cross)
- LED status indicator
- IP 20 protection
- Problem-free specification according to industry standard
- Easy and quick installation



General

Type	ECI 10-3	ECI 20-3
Product description	ECI Electronic contactors are designed for applications demanding fast and precise switching. The contactors utilize SCR power chips with new LTE (Low Thermal Expansion) technology. This unique power chip design ensures high switching capacity and long life. The contactors are burst fired for reduced EMC emission, have LED status indicators and accept universal control voltages. The units are DIN-rail mountable, complete with heat sink and require no additional components.	
Typical applications	ECI electronic contactors are designed for fast and demanding switching of loads such as heaters, solenoids, transformers and motors	
Design standard	IEC/EN 60947-4-3	
Approvals	CE, CSA and NRTL/C	
Output specifications		
Operational current, AC-1, AC-51 (heater load) AC-3, AC-53a (motor load)	10 A 10 A	20 A 10 A
Operational voltage, 3 phase (50/60 Hz)	24-230 V a.c. 24-480 V a.c. 24-600 V a.c.	
Leakage current max.	1 mA	
Minimum operational current	10 mA	
Semiconductor protection fusing type 1 co-ordination type 2 co-ordination	35 A gL/gG 450 A ² S	35 A gL/gG 450 A ² S
Thermal specifications and environment		
Power dissipation, continuous duty	3 W/A	
Power dissipation, intermittent duty	3 W/A × duty cycle	
Ambient temperature range	-5 to 40°C	
Cooling method	Natural convection	
Mounting	Vertical (see also general mounting instructions)	
Max. ambient temperature with limited current	60°C, see derating for high temperatures in chart below	
Storage temperature range	-20 to 80°C	
Protection degree/pollution degree	IP 20/3	
Insulation specifications		
Rated insulation voltage, U_i	660 V	
Rated impulse withstand voltage, U_{imp}	4 kV	
Installation category	III	
Control specifications		
Control voltage (+/- 10%)	5-24 V d.c. / 24-230 V a.c./d.c.	
Pick-up voltage	4.25 V d.c. / 20.4 V a.c./d.c.	
Drop-out voltage	1.5 V d.c. / 7.2 V a.c./d.c.	
Control current/power max.	15 mA at 4 V d.c. / 1.5 VA/6 mA at 24 V d.c.	
Response time max.	1/2 cycle / 1 cycle	
EMC immunity	Meets requirements of EN 50082-1 and EN 50082-2	

Selection guide

Operational current max. AC-1	Control voltage	Dimensions	Type	Operational voltage		
				24-230 V a.c. Code no.	24-480 V a.c. Code no.	24-600 V a.c. Code no.
10 A	5-24 V d.c.	45 mm module	ECI 10-3	037N0031	037N0033	037N0035
10 A	24-230 V a.c./d.c.	45 mm module	ECI 10-3	037N0025	037N0027	037N0029
20 A	5-24 V d.c.	90 mm module	ECI 20-3	037N0032	037N0034	037N0036
20 A	24-230 V a.c./d.c.	90 mm module	ECI 20-3	037N0026	037N0028	037N0030

Wiring diagram

Heater load (AC-1, AC-51)

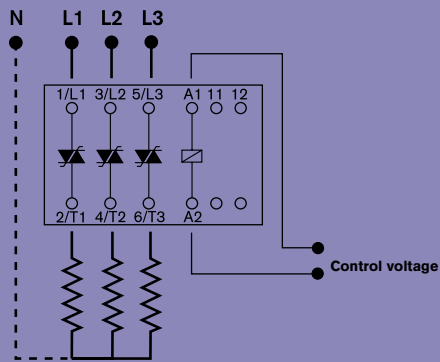

Wiring diagram

Motor load

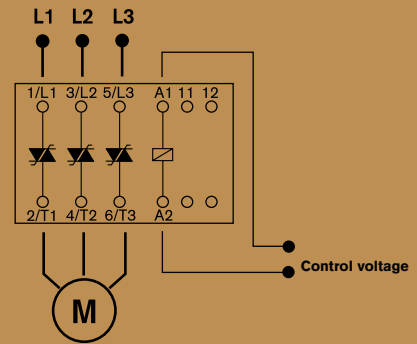

Functional diagram

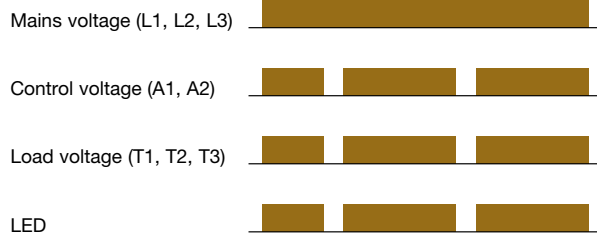

Operating at high temperatures

If the contactor is placed inside small cabinets, care must be taken to avoid exceeding the max. ambient temperature. Otherwise the current must be derated according to table.

For further information on dimensions, mounting and temperature overload protection see common information, page 26.

Ambient Temperature	ECI 10	ECI 20
40°C	10.0 A	20.0 A
50°C	8.0 A	16.0 A
60°C	6.5 A	13.0 A

Analogue power controllers Type ACI



Features

- SCR power chip with LTE technology
- Compact modular design complete with heat sink
- DIN-rail mountable
- Built-in varistor protection
- Accepts current loop, voltage and potentiometer control inputs
- Selectable phase angle and burst firing control method
- Micro-computer controlled for maximum performance
- Built-in EMC filter
- LED status indicator
- IP 20 protection
- Problem-free specification according to industry standard
- Easy and quick installation



General

Type	ACI 30-1	ACI 50-1
Product description	The versatile ACI analogue power controller is designed for very precise temperature and transformer control. Due to the built-in micro-computer the controller can operate in phase angle as well as in burst firing control method. The controller automatically adapts to the load to ensure a smooth inrush, and in burst-firing mode it will further eliminate the unwanted effects of DC magnetizing on transformers. The ACI unit is easily connected to a PLC/regulator by means of one of the selectable input signals.	
Typical applications	Analogue control of heaters and infrared lamps. The ACI controller is also ideal on transformer controlled processes.	
Design standard	IEC/EN 60947-4-3	
Approvals	CE	
Output specifications		
Operational current AC-1 (heater load) AC-56a (transformer load)	30 A 30 A	50 A 50 A
Operational voltage	208-230 V a.c. 400-480 V a.c.	
Control method	Selectable linear power or linear voltage	
Phase angle control	Selectable cycle time: 0.-60 seconds	
Burst firing control		
Leakage current max.	1 mA	
Minimum operational current	10 mA	
Semiconductor protection fusing type 1 co-ordination type 2 co-ordination	50 A gL/gG 1800 A ² S	50 A gL/gG 1800 A ² S
Thermal specifications and environment		
Power dissipation, continuous duty	1.2 W/Amp.	
Power dissipation, intermittent duty	1.2 W/Amp. × duty cycle	
Ambient temperature range	-5 to 40 °C	
Cooling method	Natural convection	
Mounting	Vertical (see also general mounting instructions)	
Max. ambient temperature with limited current	60 °C, see derating for high temperatures in chart below	
Storage temperature range	-20 to 80 °C	
Protection degree/pollution degree	IP 20/3	
Insulation specifications		
Rated insulation voltage, U _i	660 V	
Rated impulse withstand voltage, U _{imp}	4 kV	
Installation category	III	
Control specifications		
Control supply voltage	19-28 V a.c./d.c.	
Control signals:		
Current loop control	4-20 mA, 20-4 mA, 0-20 mA and 20-0 mA (voltage drop < 3 V)	
Voltage control	0-10 V d.c. and 10-0 V d.c. (input resistance > 300 kΩ)	
Potentiometer control	0-10 kΩ and 10-0 kΩ	
Isolation:		
Control inputs	Floating control input	
Voltage line to control	2.5 kV a.c.	
Voltage supply to control	500 V a.c.	
Protection	Supply and control inputs are protected against overload and over voltage	
EMC immunity	Meets requirements of EN 50082-1 and EN 50082-2	

Selection guide

Operational voltage

Operational current max. AC-1	Supply voltage	Dimensions	Type	Operational voltage	
				208-230 V a.c. Code no.	400-408 V a.c. Code no.
30 A	19-28 V a.c./d.c.	45 mm module	ACI 30-1	037N0057	037N0059
50 A	19-28 V a.c./d.c.	90 mm module	ACI 50-1	037N0058	037N0060

Control methods & function

Burst firing mode principle

Automatic load adaptation

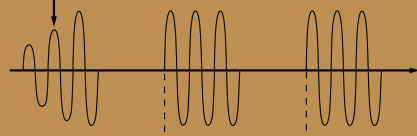

Function

Power

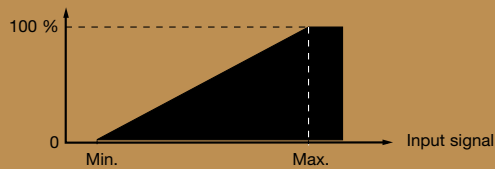

Phase angle mode principle

Automatic load adaptation

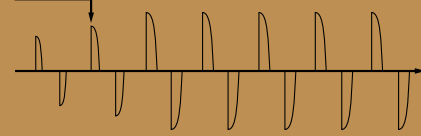

Function

Power or voltage

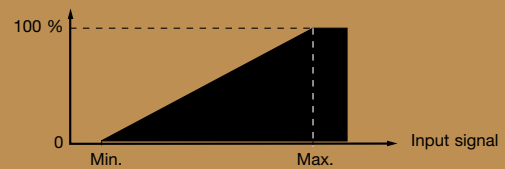

Wiring diagram

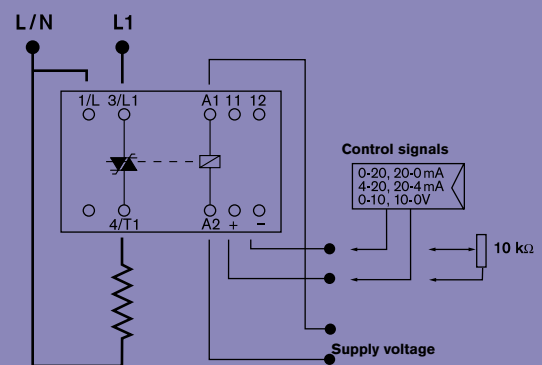

Operating at high temperatures

If the controller is placed inside small cabinets, care must be taken to avoid exceeding the max. ambient temperature. Otherwise the current must be derated according to table.

For further information on dimensions, mounting and temperature overload protection see common information, page 26.

Ambient temperature	ACI 30	ACI 50
40°C	30.0 A	50.0 A
50°C	25.0 A	40.0 A
60°C	20.0 A	30.0 A

CI-tronic™ also represents an affordable breakthrough in motor controls

Soft starters are a tested way to keep torque surges in AC motors from damaging the equipment they're meant to control — nothing new about that. What is new, however, is that now there's an affordable line of these controls designed specifically for smaller motors — the CI-tronic range from Danfoss.

CI-tronic motor controllers cover the power range from 0.1 to 15 kW. They're ideal for applications that require smooth starting and stopping but that don't call for the expense of a conventional soft starter. Use them on pumps, fans, conveyors, gear or belt-driven machinery and countless other types of equipment. They provide precise control while reducing the shocks and vibrations that are a major cause of equipment failure and downtime. In addition, by reducing inrush currents during motor startup they eliminate power dropouts that can damage sensitive electronic equipment, saving you the expense of having to reinforce the line.

There are also a variety of CI-tronic controllers for more specialized tasks. For example, our motor contactors and reversing contactors are ideal for applications with frequent starts and stops. A zero cross-switching technique is used (the contactor always switches when the voltage is zero) to ensure speed and accuracy. These reliable products provide long service on everything from automatic doors to thread cutting machines and are an effective way to control difficult functions like "inching" on cranes.

Finally, for less demanding applications it's hard to beat our starting torque limiters, which offer the dependability of CI-tronic technology at highly attractive prices.

CI-tronic motor controllers can be adjusted precisely for the needs of your application. Ramp-up and ramp-down times can be set from 0.5-10 seconds. Starting torque can be adjusted from 0-85% of nominal torque. And for applications with high breakaway torque the controller can provide a kickstart of full torque for 200 ms.



CI-tronic™

Motor controllers

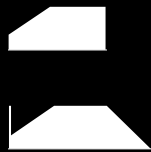

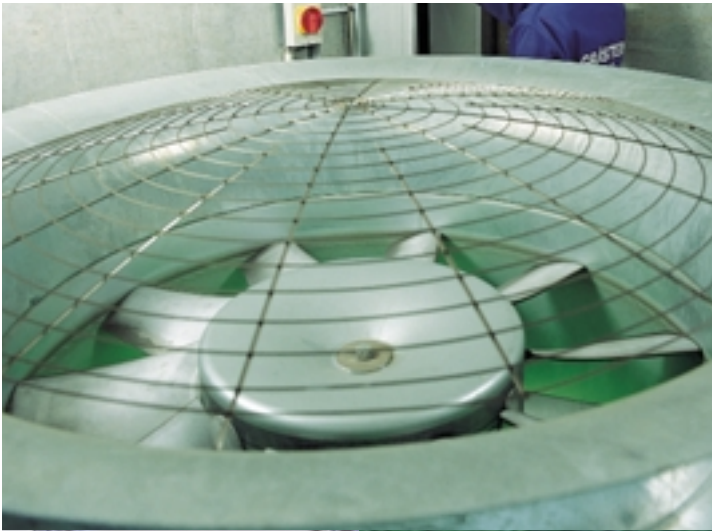

Everyone benefits

Regardless of the application, CI-tronic motor controllers provide smooth and precise starting and stopping while reducing wear and tear on your equipment. But they also benefit individual applications in specific ways.

Conveyors and packaging equipment

- Smooth operation prevents tilting and spills
- Less stress on belts/chains prevents snapping/breakage
- Long life on indexing and reversing
- Unlimited start/stop

Automatic doors

- Smooth opening and closing
- Faster operation

Cranes

- No rough stops when clutch brake is engaged
- No gearbox damage due to operator inching

Fans

- No belt squirreling or snapping
- Reduced number of belts

Pumps

- No water hammering
- No damaged piping due to pressure peaks

Compressors

- Reduced starting current eliminates line voltage drop

Tooling machines

- Long life on indexing
- Fast reversing

Motor controllers Type MCI



Features

- Individual adjustable acceleration and deceleration times, 0.5-10 seconds
- Initial torque adjustable from 0-85%
- Breakaway function (Kick Start)
- Universal control voltage: 24-480 V a.c./d.c.
- Automatic detection of missing phases
- Automatic adaptation to 50/60 Hz
- LED status indicator
- Built-in varistor protection
- Unlimited start/stop operations per hour
- Optional Aux. contacts
- IP 20 protection
- Compact DIN rail mountable design

General

Type	MCI 3	MCI 15	MCI 25
Product description	The digital controlled MCI soft starter are designed for smooth control of 3 phase AC motors. The MCI controller has individually adjustable acceleration and deceleration times. Thanks to the adjustable initial torque and the unique breakaway (kick start) function the controller can be optimized for almost any application		
Typical applications	AC motor application where a smooth start and/or stop is advantageous, such as conveyors, fans, pumps, compressors and high inertia loads. MCI controllers are also obvious as replacement of star/delta starters		
Design standard	IEC/EN 60947-4-2		
Approvals	CE, UL, UL-C and CSA		
Output specifications			
Operational current AC 3, AC 53a and AC 58a (motor load)	3 A	15 A	25 A
Motor size at: 208-230 V a.c. 400-480 V a.c. 550-600 V a.c.	0.1-0.7 kW (0.18-1 HP) 0.1-1.5 kW (0.18-2 HP) 0.1-2.2 kW (0.18-3 HP)	0.1-4.0 kW (0.18-5 HP) 0.1-7.5 kW (0.18-10 HP) 0.1-7.5 kW (0.18-10 HP)	0.1-7.5 kW (0.18-10 HP) 0.1-11 kW (0.18-15 HP) 0.1-18kW (0.18-25 HP)
Leakage current	5 mA a.c. max.		
Minimum operational current	50 mA		
Overload current profile	X-Tx: 8-3		
Overload relay trip class	Class 10		
Semiconductor protection fusing type 1 co-ordination type 2 co-ordination	25 A gL/gG 72 A ² S	50 A gL/gG 1800 A ² S	80 A gL/gG 6300 A ² S
Thermal specifications and environment			
Power dissipation, continuous duty	4 W	2 W/A	
Power dissipation, intermittent duty	4 W	2 W/A × duty cycle	
Ambient temperature range	-5 to 40°C		
Cooling method	Natural convection		
Mounting	Vertical (see also general mounting instructions)		
Max. ambient temperature with limited current	60°C, see derating for high temperatures in chart below		
Storage temperature range	-20 to 80°C		
Protection degree/pollution degree	IP 20/3		
Insulation specifications			
Rated insulation voltage, U _i	660 V		
Rated impulse withstand voltage, U _{imp}	4 kV		
Installation category	III		
Control specifications			
Control voltage (+/- 10%)	24-480 V a.c./d.c.		
Drop-out voltage	5 V a.c./d.c.		
Control current/power max.	15 mA/2 VA		
Response time max.	70 ms		
Ramp-up time	Adjustable 0-10 seconds, 0-20 seconds on version with aux. contact		
Ramp-down time	Adjustable 0-10 seconds, 0-20 seconds on version with aux. contact		
Initial torque	Adjustable 0-85% of nominal torque, with or without "kick start"		
SCR auxiliary contacts (optinal)			
Voltage/current max.	24-480 V a.c./0.5 A (AC-14, AC-15)		
Fuse max.	10 A gL/gG, I ² t max 72 A ² s		
EMC immunity	Meets requirements of EN 50082-1 and EN 50082-2		

Selection guide

Operational voltage	Motor current max.	Motor power max.	Control voltage	Dimensions	Type	Aux. contacts	Code no.
208-230 V a.c.	3 A	0.7 kW/1HP	24-480 V a.c./d.c.	22.5 mm module	MCI 3	-	037N0073
	15 A	4.0 kW/5.5 HP	24-480 V a.c./d.c.	45 mm module	MCI 15	-	037N0037
	25 A	7.5 kW/10 HP	24-480 V a.c./d.c.	90 mm module	MCI 25	-	037N0038
	25 A	7.5 kW/10 HP	24-480 V a.c./d.c.	90 mm module	MCI 25	I-0, By-pass	037N0069
400-415 V a.c. 440-480 V a.c. 400-480 V a.c.	3 A	1.5 kW/2 HP	24-480 V a.c./d.c.	22.5 mm module	MCI 3	-	037N0074
	3 A	1.5 kW/2 HP	24-480 V a.c./d.c.	22.5 mm module	MCI 3	-	037N0084
	15 A	7.5 kW/10 HP	24-480 V a.c./d.c.	45 mm module	MCI 15	-	037N0039
	25 A	11 kW/15 HP	24-480 V a.c./d.c.	90 mm module	MCI 25	-	037N0040
	25 A	11 kW/15 HP	24-480 V a.c./d.c.	90 mm module	MCI 25	I-0, By-pass	037N0070
550-600 V a.c.	3 A	2.2 kW/3 HP	24-480 V a.c./d.c.	22.5 mm module	MCI 3	-	037N0075
	15 A	7.5 kW/10 HP	24-480 V a.c./d.c.	45 mm module	MCI 15	-	037N0041
	25 A	18.5 kW/25 HP	24-480 V a.c./d.c.	90 mm module	MCI 25	-	037N0042
	25 A	18.5 kW/25 HP	24-480 V a.c./d.c.	90 mm module	MCI 25	I-0, By-pass	037N0071

Wiring and functional diagrams

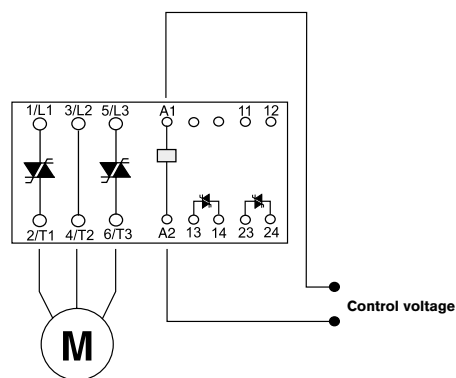

Note: Auxiliary contacts 13-14 and 23-24 is only available on some MCI 25 types MCI 3 version by-passed in steady-state mode.

Line voltage (L1, L2, L3)

Control voltage

Motor voltage T1, T2, T3

LED 1

LED 2

Aux. Contacts:

23-24 by-pass

13-14 I-0

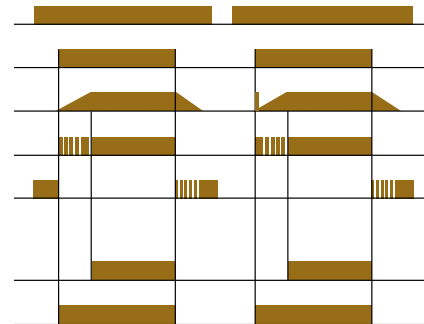

Example 1:
Soft start with initial torque and soft stop.

Example 2:
Soft start with kick start, initial torque and soft stop.

Adjustments

Control of the motor is achieved by acting on the motor voltage. The motor speed will depend on the actual load on the motor shaft. A motor with little or no load will reach full speed before the voltage has reached its maximum value. The motor controller will "read" time and torque settings in off state.

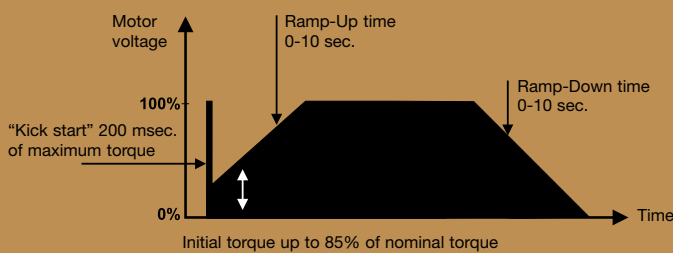

Motor overload and short circuit protection

Overload and short circuit protection of the motor is easily achieved by installing a circuit breaker on the supply side of the motor controller.

Select the circuit breaker from the selection table according to the rated nominal operational current of the motor.

For information on prospective short circuit current please refer to data for circuit breaker.

Motor full load current A	Danfoss CTI 25-M/CTI 25MB circuit breaker Code no.
0.1-0.16	047B3140
0.16-0.25	047B3141
0.25-0.4	047B3142
0.4-0.63	047B3143
0.63-1.0	047B3144
1.0-1.6	047B3145
1.6-2.5	047B3153
2.5-4.0	047B3154
4-6.3	047B3155
6-10	047B3156
10-16	047B3157
16-20	047B3158
20-25	047B3159

Operating at high temperatures

If the motor controller is placed inside small cabinets, care must be taken to avoid exceeding the max. ambient temperature. Otherwise the current must be derated according to table.

For further information on dimensions, mounting and temperature overload protection see common information, page 26.

Ambient temperature	MCI 3	MCI 15	MCI 25
40°C	3 A	15 A	25.0 A
50°C	2.5 A	12.5 A	17.5 A
60°C	2.0 A	10.0 A	15.0 A

Motor controllers with Brake, Type MCI 25B



Features

- Adjustable acceleration time, 0-10 seconds
- Initial torque adjustable from 0-85%, with or without kick start (break-away)
- Adjustable DC injection brake, 0-50 A d.c.
- Fast acting brake mode with automatic motor field reduction
- Automatic stop detection
- Universal control voltage 24-480 V a.c./d.c.
- Slow speed function, 7.5% or 10% of nom. speed
- SCR Aux. contacts for external control of by-pass, I-O and mechanical brake.
- Automatic detection of missing phase(s)
- Automatic adaptation to 50 or 60 Hz
- Unlimited start and stop per hour
- IP 20 protection
- Compact DIN rail mountable design



General

Type	MCI 25B
Product description	MCI 25B motor controller with brake is designed for soft starting and braking of 3 phase AC motors. The digital controlled soft starter features accurate settings and several monitoring functions. Acceleration time and initial torque are along with the braking torque easily adjusted. During braking the MCI 25B will apply a DC current to all the windings of the motor, thus providing a powerful brake function. The automatic stop detection ensures a safe operation. For positioning applications the unique slow speed function can be applied.
Typical applications	The MCI 25B controller is typically applied on demanding braking applications such as saws, cranes, grinding machines, automatic doors, etc.
Design standard	IEC/EN 60947-4-2
Approvals	CE, CSA and NRTL/C
Output specifications	
Operational current AC 3, AC 53a and AC 58a (motor load)	25 A
Motor size at: 208-230 V a.c. 400-480 V a.c.	0.7-7.5 kW (1-10 HP) 1-11 kW (1-15 HP)
Leakage current	5 mA a.c. max.
Minimum operational current	50 mA
Overload current profile	X-Tx: 8-3
Overload relay trip class	Class 10
Semiconductor protection fusing type 1 co-ordination type 2 co-ordination	80 A gL/gG 6300 A ² S
Thermal specifications and environment	
Power dissipation, continuous duty	2 W/A
Power dissipation, intermittent duty	2 W/A × duty cycle
Ambient temperature range	-5 to 40 °C
Cooling method	Natural convection
Mounting	Vertical (see also general mounting instructions)
Max. temperature with limited current	60 °C, see derating for high temperatures in chart below
Storage temperature range	-20 to 80 °C
Protection degree/pollution degree	IP 20/3
Insulation specifications	
Rated insulation voltage, U_i	660 V
Rated impulse withstand voltage, U_{imp}	4 kV
Installation category	III
Control specifications	
Control voltage (+/- 10%)	24-480 V a.c./d.c.
Drop-out voltage	5 V a.c./d.c.
Control current/power max.	15 mA/2 VA
Response time max.	70 ms
Ramp-up time	Adjustable 0-10 seconds
Brake current	Adjustable 0-50 A
Initial torque	Adjustable 0-85% of nominal torque, with or without "kick start"
SCR auxiliary contacts Voltage/current max. Fuse max.	24-480 V a.c./0.5 A (AC-14, AC-15) 10 A gL/gG, I^2t max 72 A ² s
EMC immunity	Meets requirements of EN 50082-1 and EN 50082-2

Selection guide

Operational voltage	Motor current max.	Motor power max.	Control voltage	Dimensions	Type	Code no.
208-230 V a.c.	25 A	7,5 kW/10 HP	24-480 V a.c./d.c.	90 mm module	MCI 25 B	037N0061
400-480 V a.c.	25 A	11 kW/15 HP	24-480 V a.c./d.c.	90 mm module	MCI 25 B	037N0062

Wiring and functional diagrams

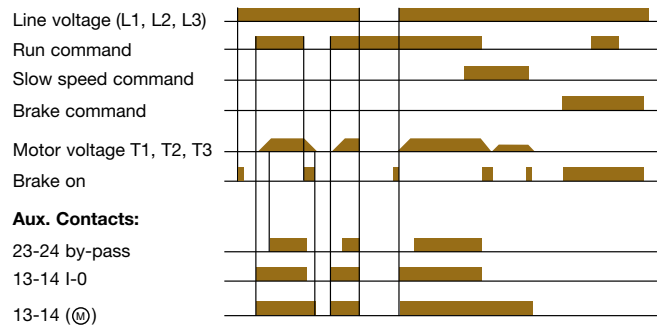
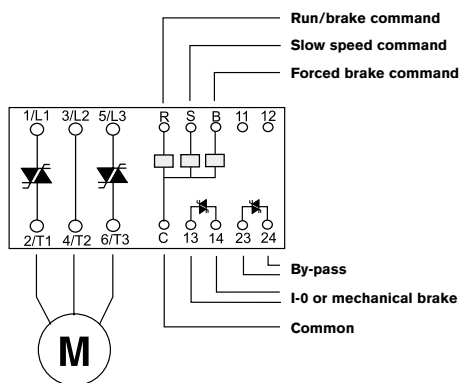

Adjustments

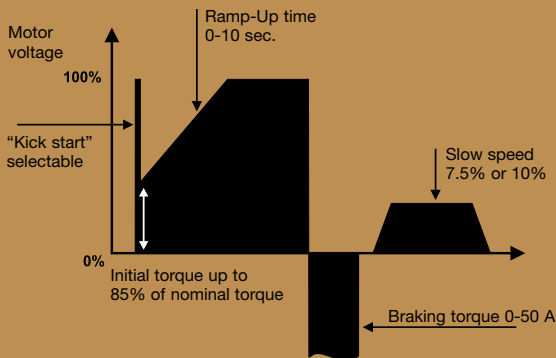

Motor overload and short circuit protection

Overload and short circuit protection of the motor is easily achieved by installing a circuit breaker on the supply side of the motor controller.

Select the circuit breaker from the selection table according to the rated nominal operational current of the motor.

For information on prospective short circuit current please refer to data for circuit breaker.

Motor full load current A	Danfoss CTI 25-M/CTI 25MB circuit breaker Code no.
1.6-2.5	047B3153
2.5-4.0	047B3154
4-6.3	047B3155
6-10	047B3156
10-16	047B3157
16-20	047B3158
20-25	047B3159

Operating at high temperatures

If the motor controller is placed inside small cabinets, care must be taken to avoid exceeding the max. ambient temperature. Otherwise the current must be derated according to table.

For further information on dimensions, mounting and temperature overload protection see common information, page 26.

Ambient temperature	MCI 25
40 °C	25.0 A
50 °C	17.5 A
60 °C	15.0 A

Starting torque limiters Type TCI



Features

- Adjustable ramp-up time, from 0.5-5 seconds
- Initial torque adjustable from 0-85%
- Single and three-phase operation
- LED status indicator
- Built-in varistor protection
- Unlimited start/stop operations per hour
- IP 20 protection
- Compact DIN-rail mountable design

General

Type	TCI 15	TCI 25
Product description	TCI starting torque limiters are designed for soft starting of 1 and 3-phase AC motors. The TCI unit is easy to install between the motor starter and the motor, and features adjustable ramp-up time and initial torque.	
Typical applications	AC motor application where a soft start is required, such as conveyors, fans, compressors and high inertia loads.	
Design standard	IEC/EN 60947-4-2	
Approvals	CE, CSA and NRTL/C	
Output specifications		
Operational current AC 3, AC 53a and AC 58a (motor load)	15 A	25 A
Motor size at: 208-240 V a.c. 380-480 V a.c. 550-600 V a.c.	0.1-4.0 kW (0.18-5.5 HP) 0.1-7.5 kW (0.18-10 HP) 0.1-10 kW (0.18-10 HP)	0.1 - 7.5 kW (0.18-10 HP) 0.1 - 11 kW (0.18-15 HP) 0.1 - 18.5 kW (0.18-25 HP)
Minimum operational current	50 mA	
Overload current profile	X-Tx: 8-3	
Overload relay trip class	Class 10	
Semiconductor protection fusing type 1 co-ordination type 2 co-ordination	50 A gL/gG 1800 A ² S	80 A gL/gG 6300 A ² S
Thermal specifications and environment		
Power dissipation, continuous duty	1 W/A	
Power dissipation, intermittent duty	1 W/A. × duty cycle	
Ambient temperature range	0 to 45°C	
Cooling method	Natural convection	
Mounting	Vertical (see also general mounting instructions)	
Max. ambient temperature with limited current	60°C, see derating for high temperatures in chart below	
Storage temperature range	-20 to 80°C	
Protection degree/pollution degree	IP 20/3	
Insulation specifications		
Rated insulation voltage, U _i	660 V	
Rated impulse withstand voltage, U _{i,imp}	4 kV	
Installation category	III	
Control specifications		
Ramp-up time	Adjustable from 0.5-5 seconds	
Initial torque	Adjustable from 0-85% of nominal torque	
EMC immunity	Meets requirements of EN 50082-1 and EN 50082-2	

Selection guide

Operational voltage	Motor current max.	Motor power max.	Dimensions	Type	Code no.
208-240 V a.c.	15 A	4.0 kW/5.5 HP	45 mm module	TCI 15	037N0045
	25 A	7.5 kW/10 HP	45 mm module	TCI 25	037N0046
380-480 V a.c.	15 A	7.5 kW/10 HP	45 mm module	TCI 15	037N0045
	25 A	11 kW/15 HP	45 mm module	TCI 25	037N0046
550-600 V a.c.	15 A	10 kW/15 HP	45 mm module	TCI 15	037N0047
	25 A	18.5 kW/25 HP	45 mm module	TCI 25	037N0048
690 V a.c.	25 A	18.5 kW/25 HP	45 mm module	TCI 25	037N0049

Wiring and functional diagrams

Single phase operation

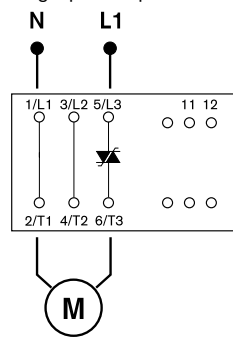

Three phase operation

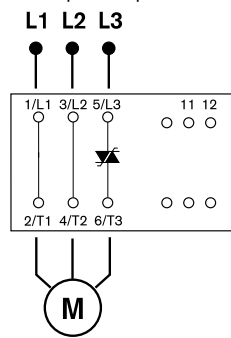

Mains voltage (L1, L2, L3)

Motor voltage

LED 1

LED 2



Adjustments

Control of the motor is achieved by acting on the motor voltage. The motor speed will depend on the actual load on the motor shaft. A motor with little or no load will reach full speed before the voltage has reached its maximum value.

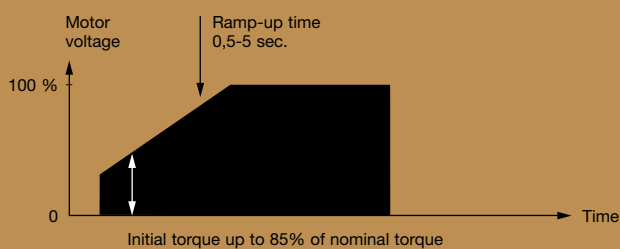

Motor overload and short circuit protection

Overload and short circuit protection of the motor is easily achieved by installing a circuit breaker on the supply side of the motor controller.

Select the circuit breaker from the selection table according to the rated nominal operational current of the motor.

For information on prospective short circuit current please refer to data for circuit breaker.

Motor full load current A	Danfoss CTI 25-M/CTI 25MB circuit breaker Code no.
0.1-0.16	047B3140
0.16-0.25	047B3141
0.25-0.4	047B3142
0.4-0.63	047B3143
0.63-1.0	047B3144
1.0-1.6	047B3145
1.6-2.5	047B3153
2.5-4.0	047B3154
4-6.3	047B3155
6-10	047B3156
10-16	047B3157
16-20	047B3158
20-25	047B3159

Operating at high temperatures

If the motor controller is placed inside small cabinets, care must be taken to avoid exceeding the max. ambient temperature. Otherwise the current must be derated according to table.

For further information on dimensions, mounting and temperature overload protection see common information, page 26.

Ambient temperature	TCI 15	TCI 25
40 °C	15 A	25 A
50 °C	15 A	25 A
60 °C	15 A	20 A

Motor contactors Type MCI-DOL



Features

- Direct on-line starting
- Long life:
AC-3: 25 mill. cycles
AC-4: 5 mill. cycles
- Universal control voltage
- LED status indicator
- Built-in varistor protection
- Unlimited start/stop operations per hour
- IP 20 protection
- Compact DIN-rail mountable design



General

Type	MCI 15 DOL
Product description	MCI-DOL electronic motor contactors are designed for fast and demanding switching of 3-phase AC motors. The contactors are burst fired for reduced EMC emission, have LED status indicators and accept universal control voltages.
Typical applications	Cranes, packaging machines and other applications with frequent inching, jogging or plugging and where a high number of operating cycles is essential.
Design standard	IEC/EN 60947-4-2
Approvals	CE, CSA and NRTL/C
Output specifications	
Operational current AC 3 (motor load)	15 A
AC 4 (motor load, inching, jogging)	15 A
Motor size at: 208-240 VAC	0.1-4.0 kW (0.18-5 HP)
400-480 VAC	0.1-7.5 kW (0.18-10 HP)
550-600 VAC	0.1-11 kW (0.18-15 HP)
Leakage current	5 mA a.c. max.
Minimum operational current	50 mA
Overload current profile	X-Tx: 8-3
Overload relay trip class	Class 10
Semiconductor protection fusing type 1 co-ordination	50 A gL/gG
type 2 co-ordination	1800 A ² S
Thermal specifications and environment	
Power dissipation, continuous duty	2 W/A
Power dissipation, intermittent duty	2 W/A × duty cycle
Ambient temperature range	0 to 40 °C
Cooling method	Natural convection
Mounting	Vertical (see also general mounting instructions)
Max. ambient temperature with limited current	60 °C, see derating for high temperatures in chart below
Storage temperature range	-20 to 80 °C
Protection degree/pollution degree	IP 20/3
Insulation specifications	
Rated insulation voltage, U_i	660 V
Rated impulse withstand voltage, U_{imp}	4 kV
Installation category	III
Control specifications	
Control voltage (+/- 10%)	24-480 V a.c., 24-60 V d.c.
Drop-out voltage	5 V a.c./d.c.
Control current/power max.	15 mA / 2 VA
Response time max.	70 ms
EMC immunity	Meets requirements of EN 50082-1 and EN 50082-2

Selection guide

Operational voltage	Motor current max.	Motor power max.	Control voltage	Dimensions	Type	Code no.
208-240 V a.c.	15 A	4.0 kW/5.5 HP	24-480 V a.c./24-60 V d.c.	45 mm module	MCI 15 DOL	037N0054
400-480 V a.c.	15 A	7.5 kW/10 HP	24-480 V a.c./24-60 V d.c.	45 mm module	MCI 15 DOL	037N0055
550-600 V a.c.	15 A	11 kW/15 HP	24-480 V a.c./24-60 V d.c.	45 mm module	MCI 15 DOL	037N0056

Wiring and functional diagrams

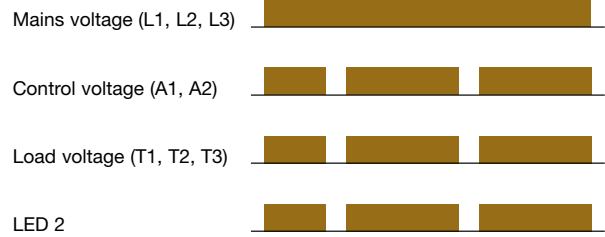
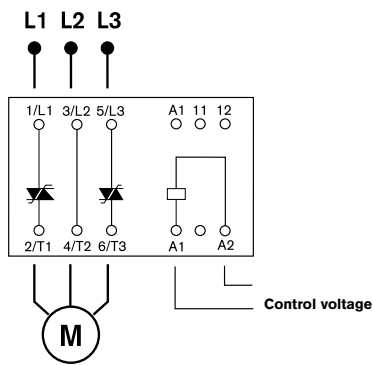

Motor overload and short circuit protection

Overload and short circuit protection of the motor is easily achieved by installing a circuit breaker on the supply side of the motor controller.

Select the circuit breaker from the selection table according to the rated nominal operational current of the motor.

For information on prospective short circuit current please refer to data for circuit breaker.

Motor full load current A	Danfoss CTI 25M/CTI 25MB circuit breaker Code no.
0.1-0.16	047B3140
0.16-0.25	047B3141
0.25-0.4	047B3142
0.4-0.63	047B3143
0.63-1.0	047B3144
1.0-1.6	047B3145
1.6-2.5	047B3153
2.5-4.0	047B3154
4-6.3	047B3155
6-10	047B3156
10-16	047B3157

Operating at high temperatures

If the unit is placed inside small cabinets, care must be taken to avoid exceeding the max. ambient temperature. Otherwise the current must be derated according to table.

For further information on dimensions, mounting and temperature overload protection see common information, page 26.

Ambient temperature	MCI 15
40°C	15 A
50°C	12.5 A
60°C	10.0 A

Reversing contactors Type RCI



Features

- Compact modular design complete with heat sink
- DIN-rail mountable
- Built-in varistor protection
- Operational current up to 10 A (AC-3)
- Line voltage up 480 V a.c.
- Built-in interlock
- Universal control voltage
- Burst firing (zero cross)
- LED status indicator
- IP 20 protection
- Problem-free specification according to industry standard
- Easy and quick installation



General

Type	RCI 10	
Product description	RCI reversing contactors are designed for demanding forward/reverse control of 3-phase AC motors. The zero cross-switching method ensures very fast and precise motor control and virtually eliminates EMC emission. The RCI reversing contactor is ideal where fast switching capability and long life are essential.	
Typical applications	Conveyors, thread cutting machines, packaging lines and other applications where fast reversing capabilities are needed.	
Design standard	IEC/EN 60947-4-2	
Approvals	CE, CSA and NRTL/C	
Output specifications		
Operational current AC-3 (Motor load)	10 A	
AC-4 (Motor load, inching, jogging)	8 A	
Motor size at: 208-240 V a.c.	AC-3: 0.1-2.2 kW (0.18-3 HP)	AC-4: 0.1-1.5 kW (0.18-2 HP)
400-480 V a.c.	AC-3: 0.1-4 kW (0.18-4 HP)	AC-4: 0.1-3 kW (0.18-4 HP)
Leakage current max.	5 mA	
Minimum operational current	50 mA	
Semiconductor protection fusing type 1 coordination	35 A gL/gG	
type 2 coordination	450 A ² S	
Thermal specifications and environment		
Power dissipation, continuous duty	1.2 W/A	
Power dissipation, intermittent duty	1.2 W/A × duty cycle	
Ambient temperature range	-5 to 60°C	
Cooling method	Natural convection	
Mounting	Vertical (see also general mounting instructions)	
Storage temperature range	-20 to 80°C	
Protection degree/pollution degree	IP 20/3	
Insulation specifications		
Rated insulation voltage, U_i	660 V	
Rated impulse withstand voltage, U_{imp}	4 kV	
Installation category	III	
Control specifications		
Control voltage (+/- 10%)	5-24 V d.c. / 24-230 V a.c./d.c.	
Pick-up voltage	4.25 V d.c. / 20.4 V a.c./d.c.	
Drop-out voltage	1.5 V d.c. / 7.2 V a.c./d.c.	
Control current/power max.	25 mA at 24 V d.c. / 6 mA / 1.5 VA at 24 V d.c.	
Response time max.	1/2 cycle / 1 cycle	
Built in switching delay on forward and reverse, max.	80 m seconds	
EMC immunity	Meets requirements of EN 50082-1 and EN 50082-2	

Selection guide

Operational voltage	Motor current max.	Motor power max.	Control voltages	Dimensions	Type	Code no.
208-240 V a.c.	10 A	2.2 kW/3 HP	5-24 V d.c.	45 mm module	RCI 10	037N0044
	10 A	2.2 kW/3 HP	24-230 V a.c./d.c.	45 mm module	RCI 10	037N0043
400-480 V a.c.	10 A	4 kW/5.5 HP	5-24 V d.c.	45 mm module	RCI 10	037N0044
	10 A	4 kW/5.5 HP	24-230 V a.c./d.c.	45 mm module	RCI 10	037N0043

Wiring and functional diagrams

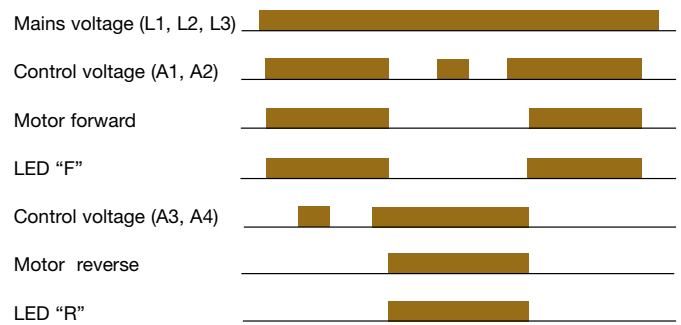
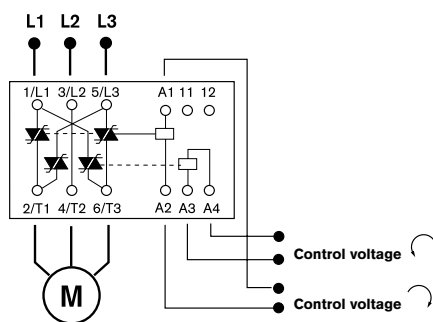

Motor overload and short circuit protection

Overload and short circuit protection of the motor is easily achieved by installing a circuit breaker on the supply side of the motor controller.

Select the circuit breaker from the selection table according to the rated nominal operational current of the motor.

For information on prospective short circuit please refer to data for circuit breaker.

Motor full load current A	Danfoss CTI 25M/CTI 25MB circuit breaker Code no.
0.1-0.16	047B3140
0.16-0.25	047B3141
0.25-0.4	047B3142
0.4-0.63	047B3143
0.63-1.0	047B3144
1.0-1.6	047B3145
1.6-2.5	047B3153
2.5-4.0	047B3154
4-6.3	047B3155
6-10	047B3156

For further information on dimensions, mounting and temperature overload protection see common information, page 26.

Temperature overload protection

Thermal overload protection of controller

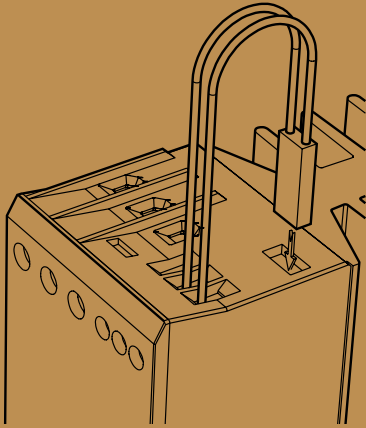

Optional thermal overload protection is possible by inserting a thermostat in the slot on the right-hand side of the controller.

Order: UP62 thermostat 037N0050

Wiring of overload protection

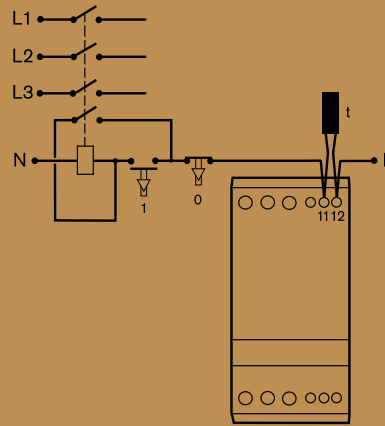

The thermostat is connected in series with the control circuit of the main contactor. When the temperature of the heat sink exceeds 100°C the main contactor will be switched OFF. A manual reset is necessary to restart this circuit.

Mounting instruction in mm (inches)

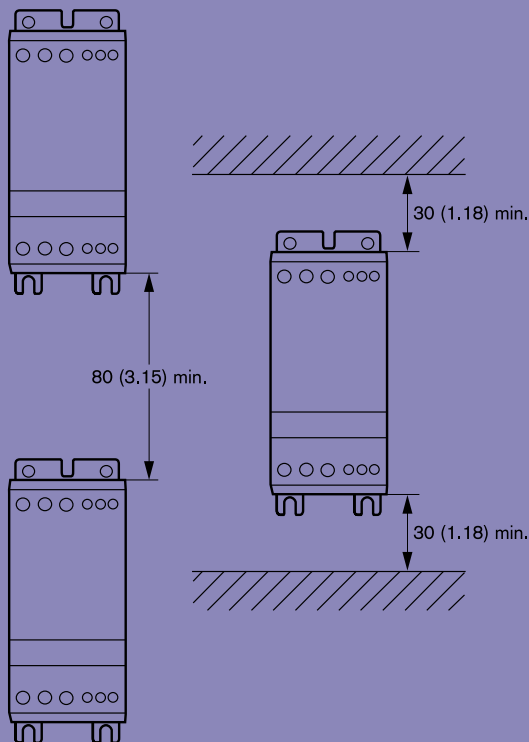

If unit is mounted horizontally, derate current by 50%. Keep heat sink clean. Airflow should not be blocked.

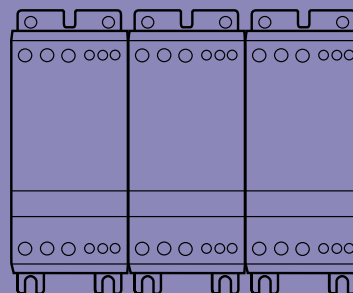
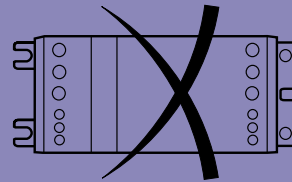

Dimensions in mm (inches)

Type ECI 15, MCI 3

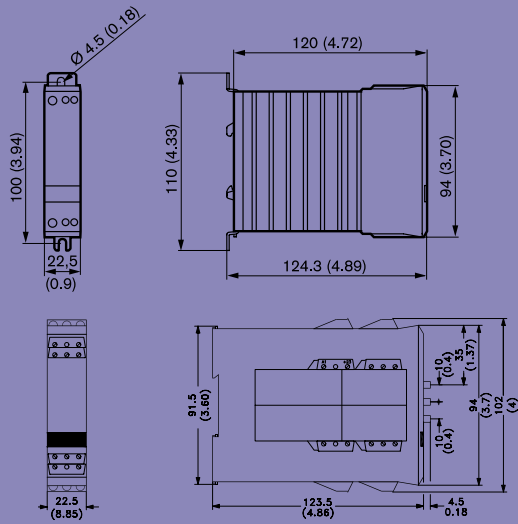

Type ACI 15, ECI 30, MCI 15, TCI 15, TCI 25, RCI 10, and MCI 15DOL

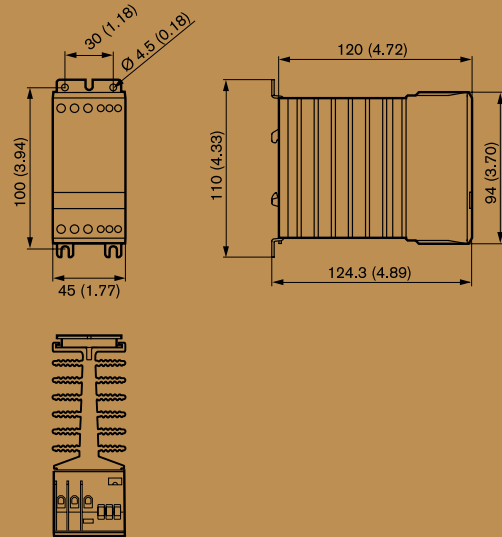

Type ACI 50, ECI 50

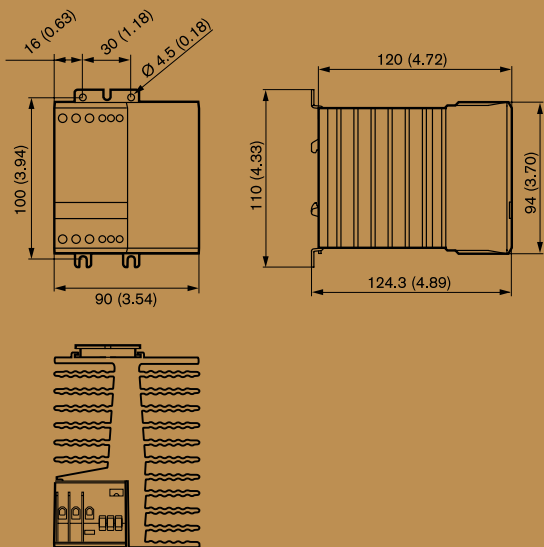

Type MCI 25, MCI 25B

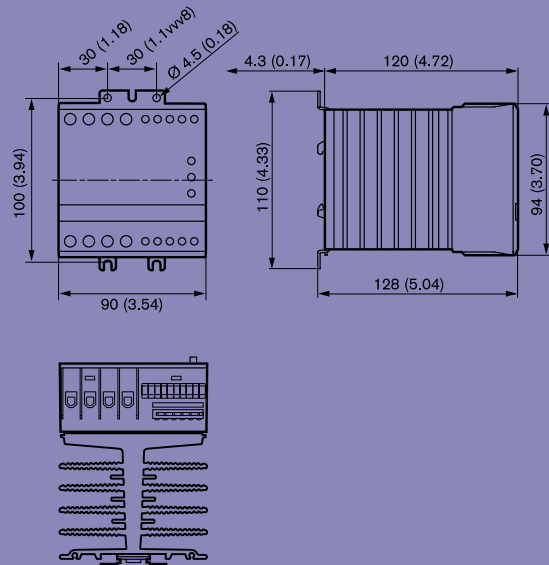

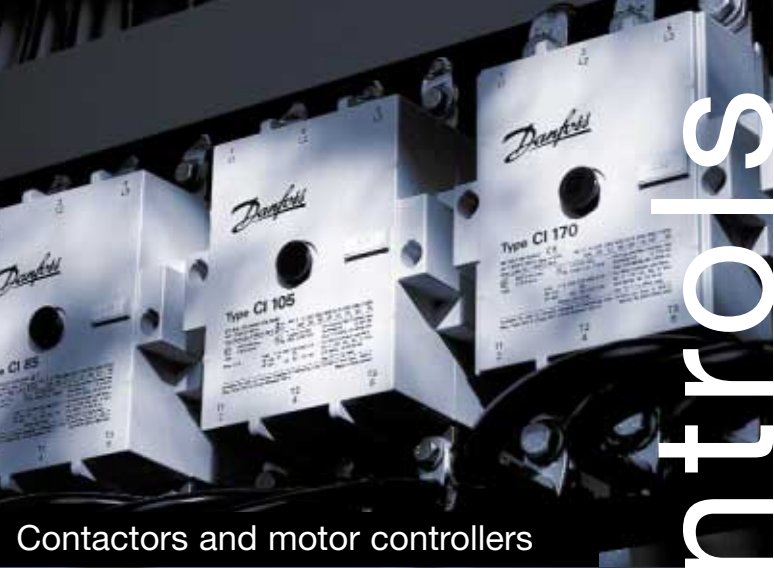

Contactors and motor controllers



Pressure and temperature controls

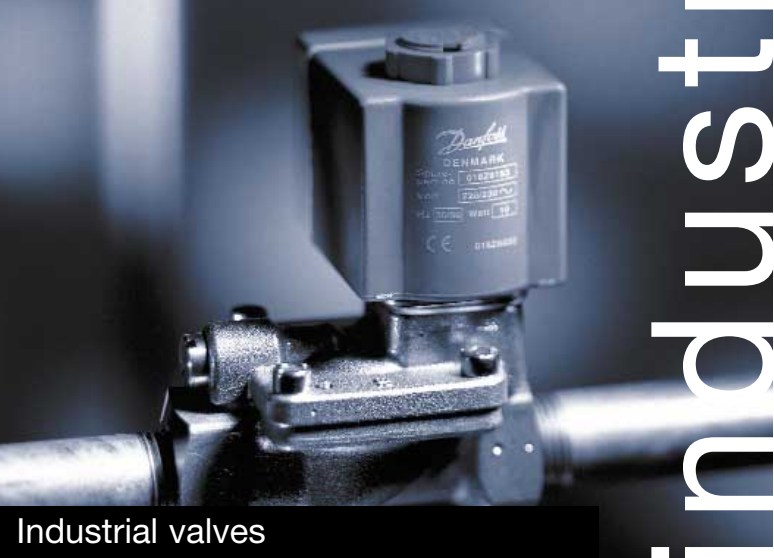

Industrial valves

Industrial controls

One call and you're in control

One call to Danfoss gives you access to an entire range of high-quality industrial controls. The Danfoss line encompasses components for industrial monitoring and control systems based on the principles of pressure and temperature measurement, electrical power, and fluid control, and includes:

- Electro-mechanical contactors
- Electronic contactors and motor controllers
- Pressure and temperature switches
- Pressure transmitters
- Temperature sensors and transmitters
- Solenoid valves
- Externally operated valves
- Thermostatically operated valves

Given their important monitoring and control functions, Danfoss components are designed for accuracy, reliability and long life. And our determination to guarantee a high-quality product is matched by an equally strong commitment to customer service. A specialist in the Danfoss industrial controls group can advise you on product selection and configuration, based on long experience in your industry. You'll find that with sales and service centers in over 100 countries, Danfoss is usually only a local call away.

Danfoss can accept no responsibility for possible errors in catalogues, brochures and other printed material. Danfoss reserves the right to alter its products without notice. This also applies to products already on order provided that such alterations can be made without subsequential changes being necessary in specifications already agreed. All trademarks in this material are property of the respective companies. Danfoss and the Danfoss logotype are trademarks of Danfoss A/S. All rights reserved.

