

**SINGLE-PHASE GLASS PASSIVATED**  
**SILICON BRIDGE RECTIFIER**

**VOLTAGE RANGE 50 to 1000 Volts CURRENT 2.0 Ampere**

**FEATURES**

- \* Ideal for printed circuit board
- \* Mounting position: Any

**MECHANICAL DATA**

- \* UL listed the recognized component directory, file #E94233
- \* Epoxy: Device has UL flammability classification 94V-0

**MAXIMUM RATINGS AND ELECTRICAL CHARACTERISTICS**

Ratings at 25 °C ambient temperature unless otherwise specified.  
 Single phase, half wave, 60 Hz, resistive or inductive load.  
 For capacitive load, derate current by 20%.

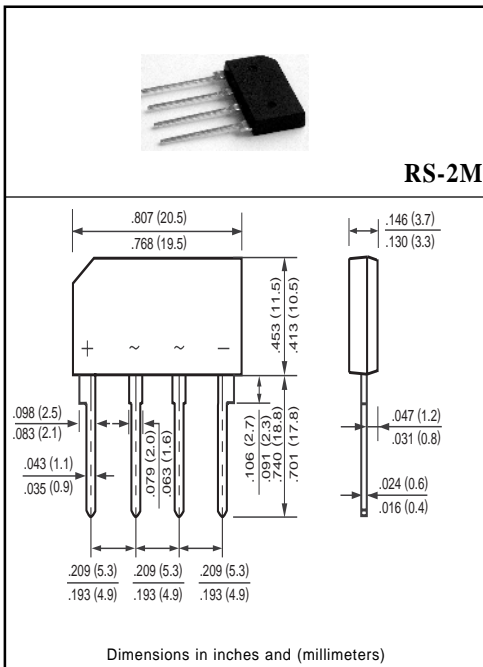

**MAXIMUM RATINGS** (At TA = 25°C unless otherwise noted)

RATINGS	SYMBOL	RS201M	RS202M	RS203M	RS204M	RS205M	RS206M	RS207M	UNITS
Maximum Recurrent Peak Reverse Voltage	VRRM	50	100	200	400	600	800	1000	Volts
Maximum RMS Bridge Input Voltage	VRMS	35	70	140	280	420	560	700	Volts
Maximum DC Blocking Voltage	VDC	50	100	200	400	600	800	1000	Volts
Maximum Average Forward Output Current TA = 50°C	IO				2.0				Amps
Peak Forward Surge Current 8.3 ms single half sine-wave superimposed on rated load (JEDEC method)	IFSM				50				Amps
Typical Junction Capacitance (Note1)	CJ				15				pF
Typical Thermal Resistance per leg (NOTE 2) (NOTE 3)	RθJA				37				°C/W
	RθJC				11				
Operating Temperature Range	TJ				-55 to + 150				°C
Storage Temperature Range	TSTG				-55 to + 150				°C

**ELECTRICAL CHARACTERISTICS** (At TA = 25°C unless otherwise noted)

CHARACTERISTICS	SYMBOL	RS201M	RS202M	RS203M	RS204M	RS205M	RS206M	RS207M	UNITS
Maximum Forward Voltage Drop per Bridgeat Element at 2.0A DC	VF				1.1				Volts
Maximum Reverse Current at Rated Dc Blocking Voltage per element	@ TA = 25°C				5.0				uAmps
	@ TA = 100°C				0.5				mAmps

NOTES: 1. Measured at 1 MHz and applied reverse voltage of 4.0 volts  
 2. Unit case mounted on 1.6 x 1.6 x 0.06" thick (4.0 x 4.0 x 0.15cm) Al. Plate  
 3. Units mounted on P.C.B. with 0.5 x 0.5" (12 x 12mm) copper pads and 0.375" (9.5mm) lead length  
 4. "Fully ROHS compliant", "100% Sn plating (Pb-free)".

# RATING AND CHARACTERISTIC CURVES ( RS201M THRU RS207M )

FIG. 1 - MAXIMUM NON-REPETITIVE FORWARD SURGE CURRENT

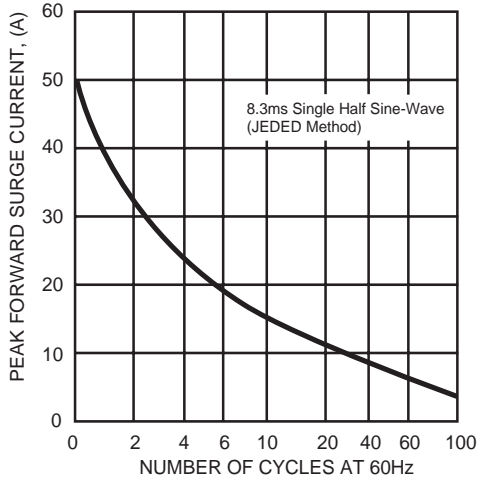

FIG. 2 - TYPICAL FORWARD CURRENT DERATING CURVE

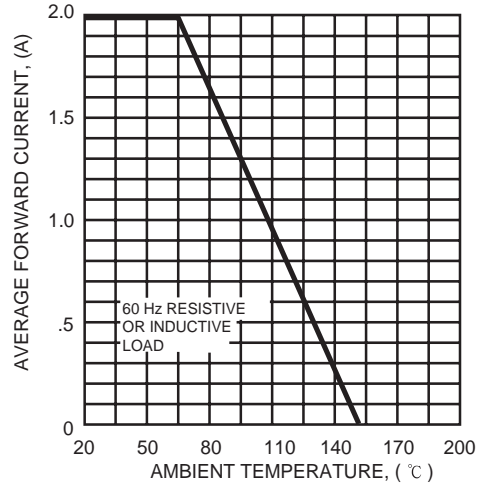

FIG. 3 - TYPICAL INSTANTANEOUS FORWARD CHARACTERISTICS

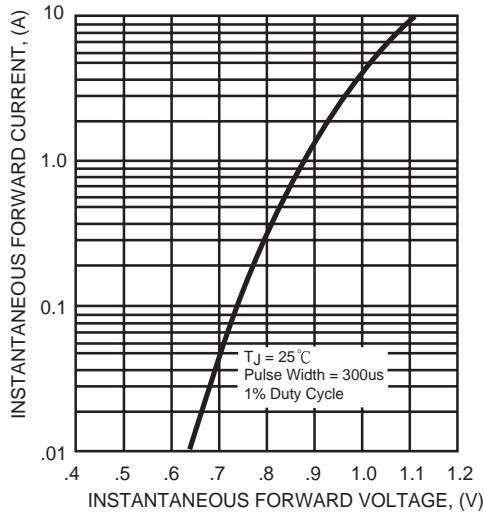

FIG. 4 - TYPICAL REVERSE CHARACTERISTICS

