Large Diameter (56mm), Housed Two and Three Channel Optical Encoders

Technical Data

HEDL-65XX HEDM-65XX HEDS-65XX Series

Features:

- **Two Channel Quadrature Output with Optional Index Pulse**
- **TTL Compatible Single Ended Outputs on HEDS Series**
- **100°C Operating Temperature**
- **Industry Standard 26C31 CMOS Line Driver IC on HEDL Series**
- **Easy Assembly, No Signal Adjustment Necessary**
- **Resolutions up to 1024 Counts Per Revolution**
- **Maximum Shaft Diameter of 5/8 Inches**
- **Single +5 V Supply**

Description

The HEDS-65XX/HEDL-65XX are high performance two and three channel optical incremental encoders. These encoders emphasize high reliability, high resolution, and easy assembly. Each encoder contains a lensed LED source (emitter), an integrated circuit with detectors and output circuitry, and a codewheel which rotates between the emitter and detector integrated circuit. The outputs of the HEDS-6500 are two single ended square waves in quadrature. The HEDL-65XX outputs are differential.

The HEDS-6540 / HEDL-6540 also have a third channel index output in addition to the two quadrature outputs. This index is an active high pulse that occurs once every full rotation of the codewheel. Resolutions up to 1024 Counts Per Revolution are available in the two and three channel versions.

The line driver option offers enhanced performance when the encoder is used in noisy environments, or when it is required to drive long distances.

The line driver option utilizes an industry standard line driver IC (26C31) which provides complementary outputs for each encoder channel. Thus the outputs of the line driver encoder are A and \bar{A} , B and \bar{B} , and I and \bar{I} for three channel versions.



Suggested line receivers are 26C32 and 26C33.

The quadrature signals are accessed through a cable and 10-pin female connector. Please refer to the ordering information at the end of this data sheet for a selection matrix.

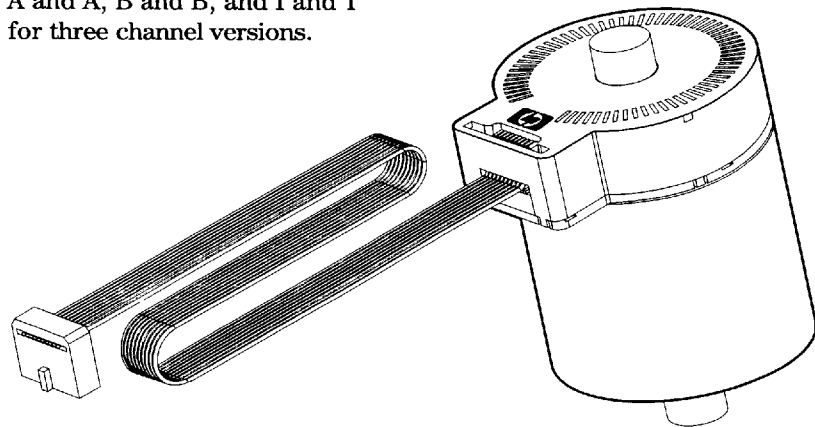

Applications

The HEDS-65XX / HEDL-65XX provide motion detection to a

very high resolution and accept a variety of shaft sizes up to a maximum of 5/8 inches.

Typical applications include printers, plotters, tape drives, positioning tables, and automatic handlers.

Assembled Unit

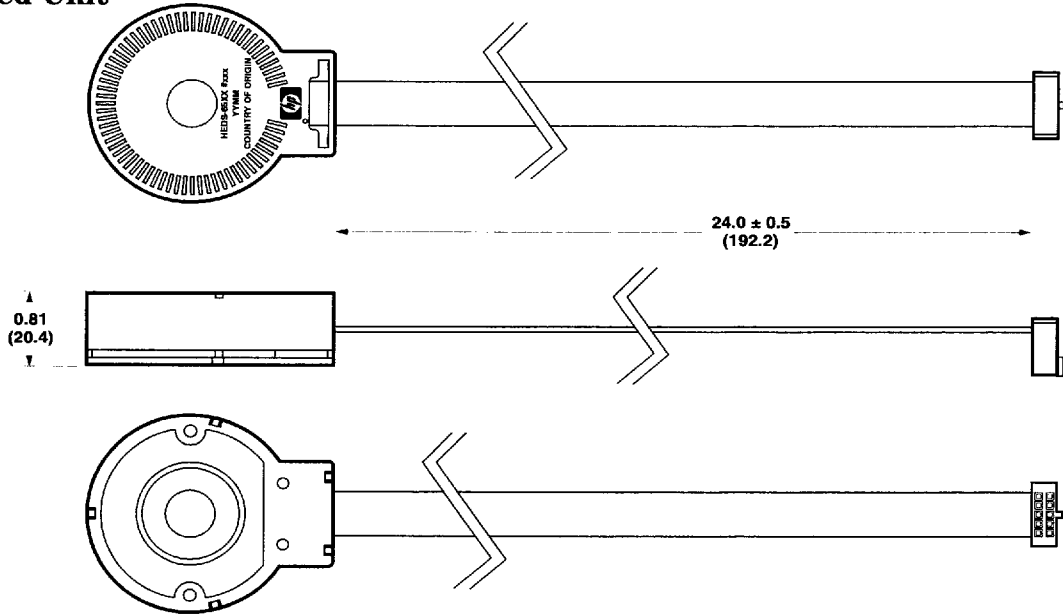

Base Plate

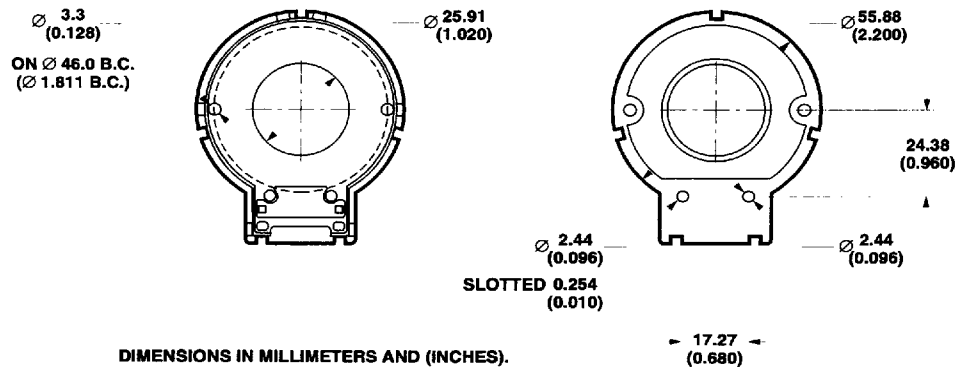

Top Cover (Housing)

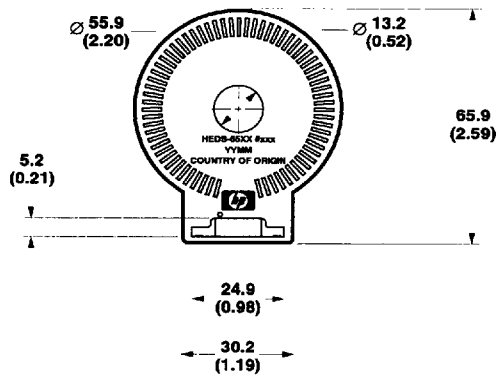

4447584 0017913 9T8

Pinout A

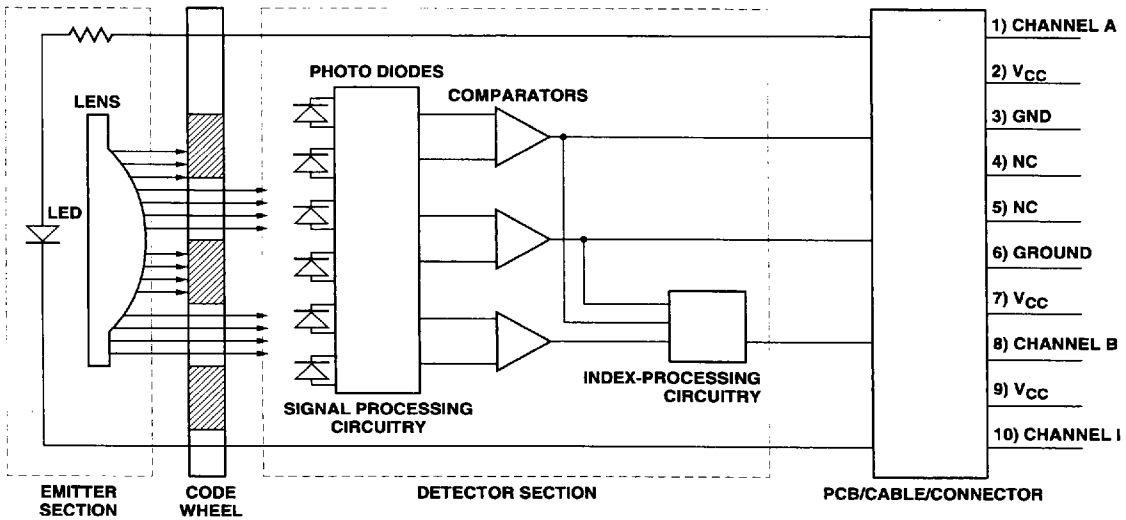

Pinout B

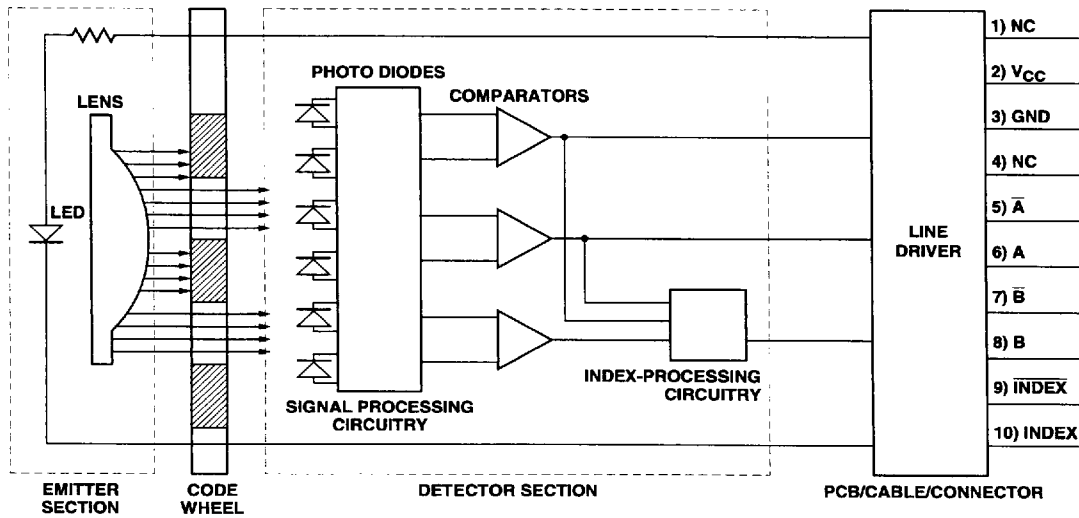

There are two different connector pin-out configurations used with the HEDS-65XX / HEDL-65XX series of encoders. The table below relates the part to its connector pin-out.

Connector Pin-out

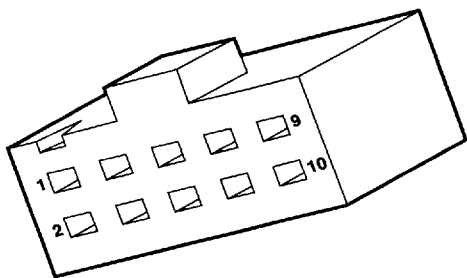

Pinout A

HEDS-65XX CONNECTOR PIN OUT
1 Channel A
2 V _{cc}
3 GND
4 NC
5 NC
6 GND
7 V _{cc}
8 Channel B
9 V _{cc}
10 Channel I

Pinout B

HEDL-65XX CONNECTOR PIN OUT
1 NC
2 V _{cc}
3 GND
4 NC
5 A-bar
6 A
7 B-bar
8 B
9 I (INDEX)
10 I (INDEX)

Theory of Operation

The HEDS-65XX / HEDL-65XX translate the rotary motion of a shaft into either a two or three channel digital output.

The HEDS-65XX uses one of the standard HEDS-9000 or HEDS-9040 modules for encoding purposes. The HEDL-654X uses the standard HEDL-9040 for encoding purposes.

As seen in the block diagram, these modules contain a single Light Emitting Diode (LED) as their light source (emitter). The light is collimated into a single parallel beam by means of a plastic lens located directly over the LED. Opposite the emitter is the integrated detector circuit (detector). This circuit consists of multiple sets of photodetectors and the signal processing circuitry necessary to produce the digital waveforms.

The codewheel rotates between the emitter and detector, causing the light beam to be interrupted by a pattern of spaces and bars on the codewheel. The photodiodes which detect these interruptions are arranged in a pattern that corresponds to the radius and design of the codewheel. These detectors are also spaced such that a light period on one pair of detectors corresponds to a dark period on the adjacent pair of detectors. The photodiode outputs are then fed into the signal processing circuitry resulting in A, \bar{A} , B, and \bar{B} (I and \bar{I} also in the three channel encoders).

Comparators receive these signals and produce the final outputs for channels A and B. Due to this integrated phasing technique, the digital output of channel A is in quadrature with that of channel B (90 degrees out of phase).

In the HEDS-6540 / HEDL-6540 the output of the comparator for the index pulse is combined with that of the outputs of channel A and channel B to produce the final index pulse. The index pulse is generated once every rotation of the codewheel and is a one state width (nominally 90 electrical degrees), true high index pulse. It is coincident with the low states on channels A and B.

Definitions

Count (N): The number of bar and window pairs or counts per revolution (CPR) of the codewheel.

One Cycle (C): 360 electrical degrees (e), 1 bar and window pair.

One Shaft Rotation: 360 mechanical degrees, N cycles.

Position Error ($\Delta\theta$): The normalized angular difference between the actual shaft position and the position indicated by the encoder cycle count.

Cycle Error (ΔC): An indication of cycle uniformity. The difference between an observed shaft angle which gives rise to one electrical cycle, and the nominal angular increment of $1/N$ of a revolution.

Pulse Width (P): The number of electrical degrees that an output is high during one cycle. This value is nominally 180 e or $1/2$ cycle.

Pulse Width Error (ΔP): The deviation, in electrical degrees, of the pulse width from its ideal value of 180 e.

State Width (S): The number of electrical degrees between a transition in the output of channel A and the neighboring transition in the output of channel B. There are 4 states per cycle, each nominally 90 e.

State Width Error (ΔS): the deviation, in electrical degrees, of each state width from its ideal value of 90 e.

Phase (Φ): the number of electrical degrees between the center of high state on channel A and the center of the high state on channel B. This value is nominally 90 e for quadrature output.

Phase Error ($\Delta\Phi$): The deviation of the phase from its ideal value of 90 e.

Direction of Rotation: When the codewheel rotates in a counter-clockwise direction (when viewed from the encoder end of the motor) channel A will lead channel B. If the codewheel rotates in the clockwise direction channel B will lead channel A.

Index Pulse Width (P₀): The number of electrical degrees that an index output is high during one full shaft rotation. This value is nominally 90 e or $1/4$ cycle.

Output Waveforms

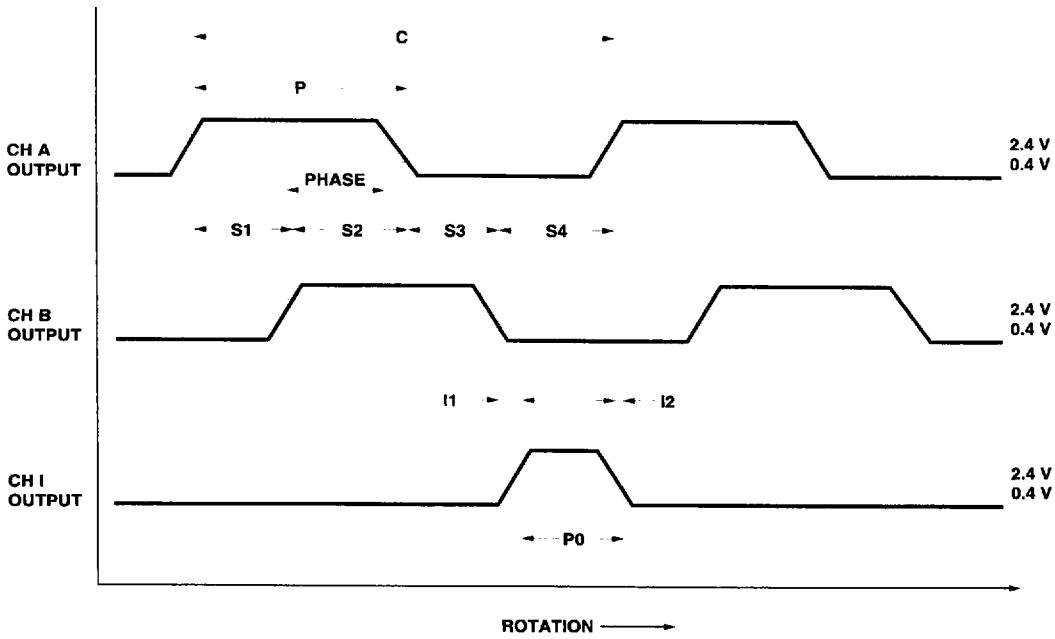

Waveforms for Encoders without Line Drivers.

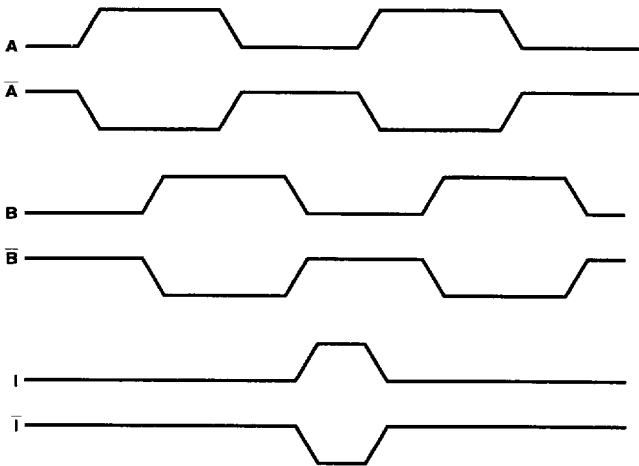

Waveforms for Encoders with Line Drivers.
(Meets all requirements of EIA-422.)

Absolute Maximum Ratings

Parameter	HEDS-6500	HEDS-6540	HEDL-6540	HEDL-6545	
Storage Temperature	-40 to +100	-40 to +100	-40 to +100	-40 to +100	Celsius
Operating Temperature	-40 to +100	-40 to +100	-40 to +100	-40 to +100	Celsius
Supply Voltage	-.5 to +7	-.5 to +7	-.5 to +7	-.5 to +7	Volts
Output Voltage	-.6 to V_{CC}	-.6 to V_{CC}	-.6 to V_{CC}	-.6 to V_{CC}	Volts
Output Current Per Channel	-1 to 5	-1 to 5			mA
Velocity	30,000	30,000	30,000	30,000	RPM
Vibration	20	20	20	20	Gs
Shaft Axial Play	5	5	5	5	Inch/1000
Radial Play & Eccentricity	2	2	2	2	Inch/1000

Recommended Operating Conditions

Parameter	HEDS-6500	HEDS-6540	HEDL-6540	HEDL-6545	
Temperature	-40 to +100	-40 to +100	-40 to +100	-40 to +100	Celsius
Supply Voltage	4.5 to 5.5	4.5 to 5.5	4.5 to 5.5	4.5 to 5.5	Volts
Load Capacitance	100	100	100	100	pF
Count Frequency	100	100	100	100	kHz
Shaft Eccentricity Plus Radial Play	$\pm .05$ ($\pm .002$)	$\pm .05$ ($\pm .002$)	$\pm .05$ ($\pm .002$)	$\pm .05$ ($\pm .002$)	mm (Inch/1000)

Note: The HEDS-65XX performance is guaranteed to 100 kHz but can operate at higher frequencies. For frequencies above 100 kHz it is recommended that the load capacitance not exceed 25 pF and pull up resistors of 3.3 k Ω between the output channels and V_{CC} are included.

Encoding Characteristics

Encoding Characteristics over Recommended Operating Range and Recommended Mounting Tolerances unless otherwise specified. Values are for the worst error in the full rotation.

Part Number	Description	Symbol	Min.	Typ.*	Max.	Units
HEDS-6500***	Pulse Width Error	ΔP		5	35	e
	Logic State Width Error	ΔS		5	35	e
	Phase Error	$\Delta \Phi$		2	15	e
	Position Error	$\Delta \Theta$		7	20	min. of arc
	Cycle Error	ΔC		5	5.5	e
HEDS-6540**	Pulse Width Error	ΔP		5	35	e
	Logic State Width Error	ΔS		5	35	e
	Phase Error	$\Delta \Phi$		2	15	e
	Position Error	$\Delta \Theta$		7	20	min. of arc
	Cycle Error	ΔC		5	5.5	e
	Index Pulse Width	ΔP_0	55	90	125	e
	CH I fall after CH B or CH A fall					
	-25°C to +100°C	t1	10	100	250	ns
	-40°C to +100°C	t1	-300	100	250	ns
	CH I rise after CH B or CH A rise					
-25°C to +100°C	t2	70	150	300	ns	
-40°C to +100°C	t2	70	150	1000	ns	
HEDL-654X	Pulse Width Error	ΔP		5	35	e
	Logic State Width Error	ΔS		5	35	e
	Phase Error	$\Delta \Phi$		2	15	e
	Position Error	$\Delta \Theta$		7	20	min. of arc
	Cycle Error	ΔC		5	5.5	e
	Index Pulse Width	ΔP_0		90		e

*Typical values specified at $V_{CC} = 5.0$ V and 25°C.

**HEDS-6540 – Active high Index part. Pull-up of 2.7 k Ω used on all outputs of modules that do not have a line driver.

***HEDS-6500 – 3.3 k Ω pull-up resistors used on all encoder module outputs.

Electrical Characteristics

Electrical Characteristics over Recommended Operating Range, typical at 25°C.

Part Number	Symbol*	Min.	Typ.	Max.	Units	Notes
HEDS-6500	I _{CC}		17	40	mA	I _{OH} = -40 µA max I _{OL} = 3.2 mA C _L = 25 pF, R _L = 11 kΩ pull-up.
	V _{OH}	2.4			V	
	V _{OL}			0.4	V	
	t _r		200		ns	
	t _f		50		ns	
HEDS-6540	I _{CC}	30	57	85	mA	I _{OH} = -200 µA max I _{OL} = 3.86 mA C _L = 25 pF, R _L = 3.3 kΩ pull-up.
	V _{OH}	2.4			V	
	V _{OL}			0.4	V	
	t _r		180		ns	
	t _f		40		ns	

*Explanation for symbols.

I_{CC} – Supply current, V_{OH} – High Level Output Voltage, V_{OL} – Low Level Output Voltage, t_r – Rise Time, t_f – Fall Time.

Electrical Interfaces

To insure reliable encoding performance, the HEDS-6540 three channel encoder requires 2.7 kΩ pull-up resistors to the supply voltage on each of the three output lines Ch. A, Ch. B, and Ch. I located as close as possible to the encoder (less than 4 feet).

Mechanical Characteristics

Parameter	Symbol	Dimensions	Tolerances ^[1]	Units
Moment Of Inertia	J	7.7 (110 x 10 ⁻⁶)		gcm ² (oz-in-s ²)
Required Shaft Length ^[2]		15.9 (0.625)	± 0.6 (.024)	mm (inches)
Bolt Circle ^[3]		46.0 (1.811)	± 0.13 (.005)	mm (inches)
Mounting Screw Size ^[4]		2.5 x 0.45 x 5		mm
Pan Head Style		#2-56 x 3/16		Inches
Encoder Base Plate Thickness		3.04 (120)		mm (inches)
Mounting Screw Torque		1.0 (0.88)		Kg (in-lbs)
Hub Set Screw		UNC #2-56		Hex head set screw

Notes:

1. These are tolerances required of the user.
2. Through hole in the encoder housing are also available, for longer shafts.
3. The HEDL-65X0 must be aligned using the aligning pins as specified in the section on "MOUNTING CONSIDERATIONS."
4. The recommended mounting screw torque for 2 screws is 1.0 Kg (0.88 in-lbs).

Mounting Considerations

The HEDS-654X/HEDL-654X must be aligned with respect to the optical center (codewheel shaft) as indicated in the following figure.

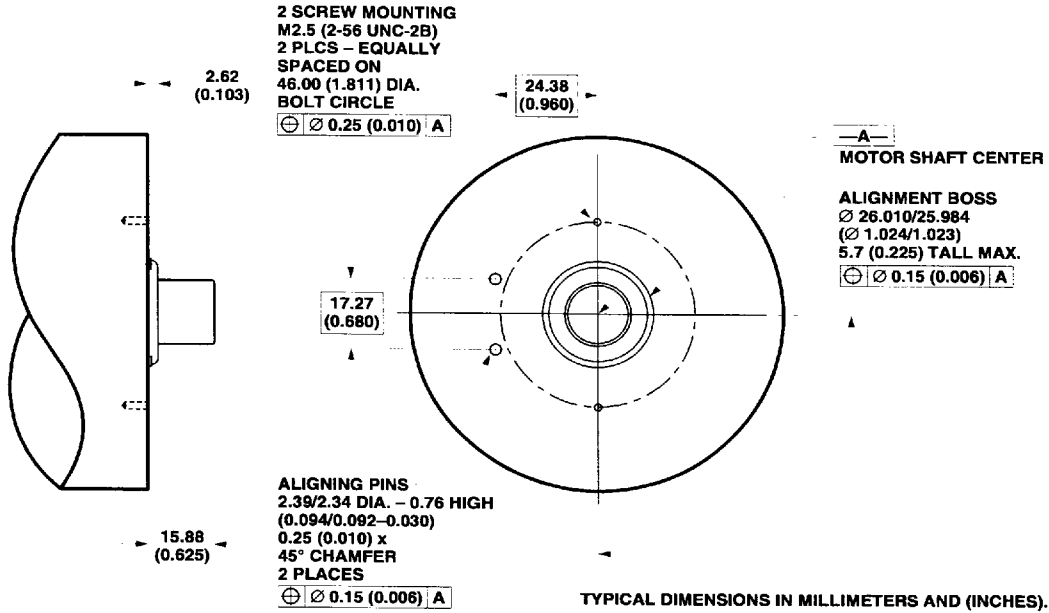

If neither locating pins nor locating boss are available, then a centering tool supplied by HP can be used (HEDS-6510).

The following figure shows how the main encoder components are organized.

Encoder Mounting and Assembly

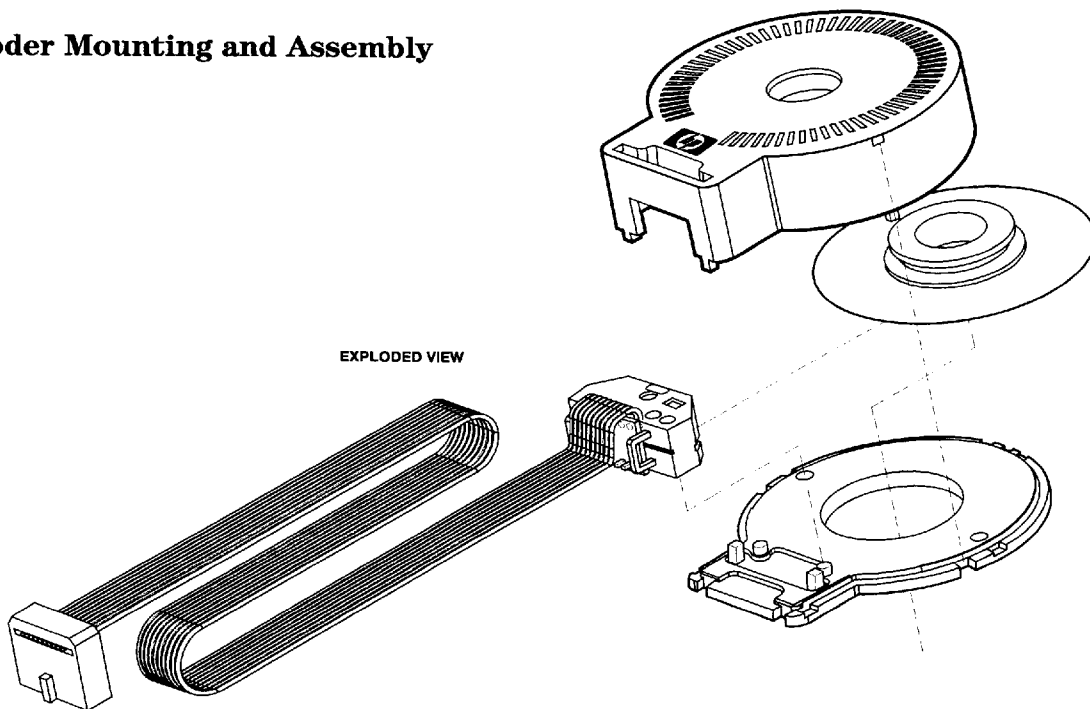

1

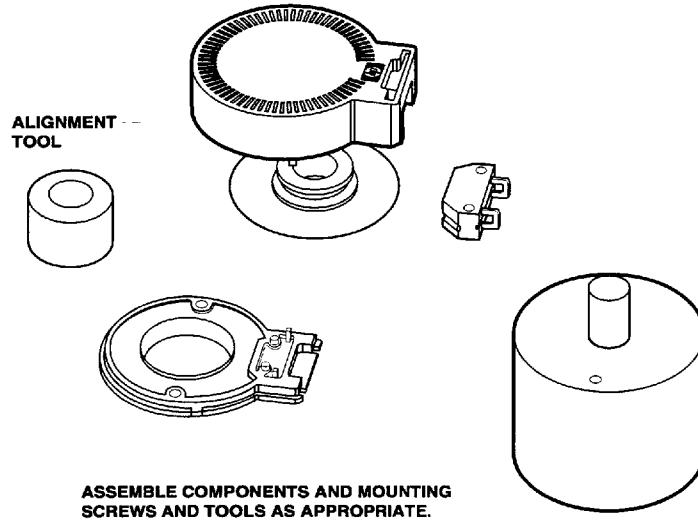

2

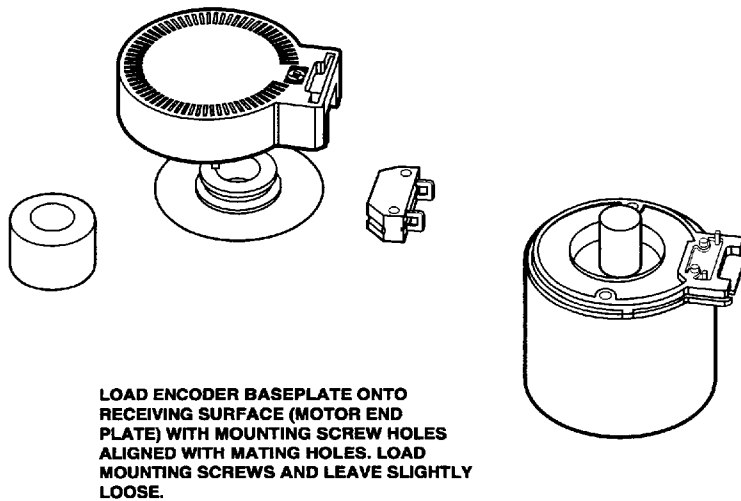

3

LOCATE ENCODER BASEPLATE

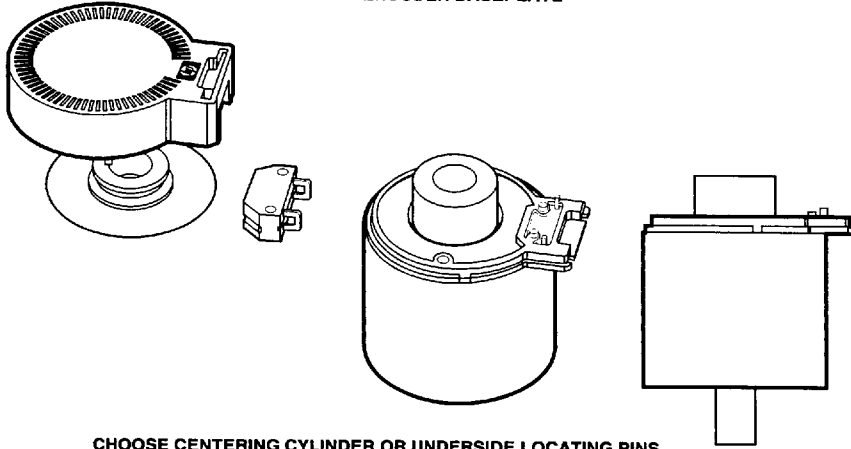

CHOOSE CENTERING CYLINDER OR UNDERSIDE LOCATING PINS.

CENTERING CYLINDER: LOCATE ENCODER BASEPLATE WITH CENTERING CYLINDER. WHEN IN PLACE, TIGHTEN MOUNTING SCREWS.

LOCATING PINS: WITH LOCATING PINS PROPERLY SEATED IN CORRESPONDING RECEIVING HOLES IN ENCODER BASEPLATE, TIGHTEN MOUNTING SCREWS.

4

LOCATE ENCODER MODULE AND CODEWHEEL

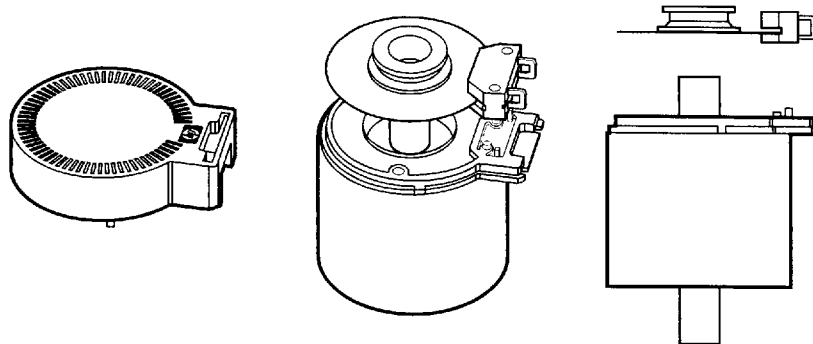

ALIGN ENCODER MODULE AND CODEWHEEL AS SHOWN. BE CAREFUL NOT TO DAMAGE THE ENCODER INTERNAL COMPONENTS WITH THE CODEWHEEL.

BRING THE ENCODER MODULE AND CODEWHEEL DOWN SUCH THAT THE ENCODER MODULE LOCATING HOLES (ON ITS UNDERSIDE) MATE WITH THE BASEPLATE ROUND PINS. THE BASEPLATE SQUARE PINS SHOULD SEAT INTO THE ENCODER MODULE MOUNTING THRU HOLES.

CONCURRENTLY, BRING THE CODEWHEEL DOWN ONTO THE MATING SHAFT.

5

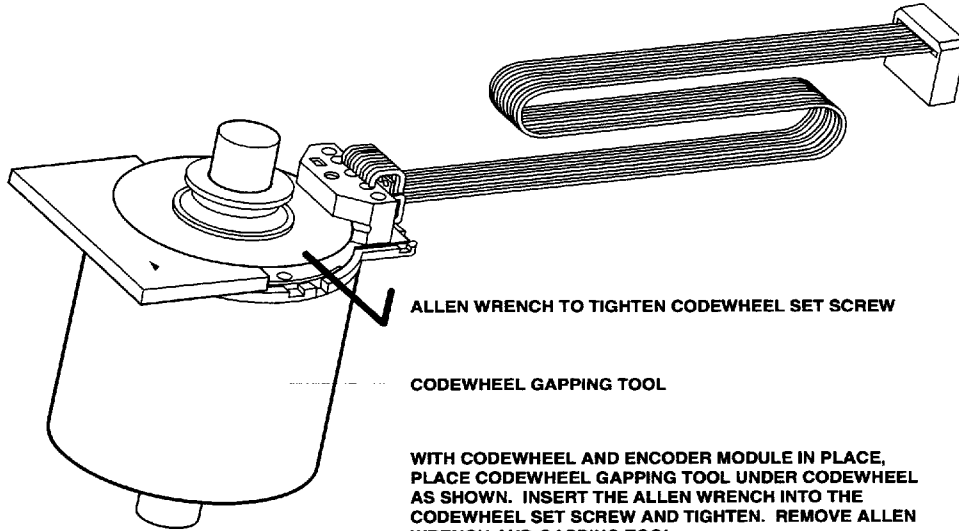

6

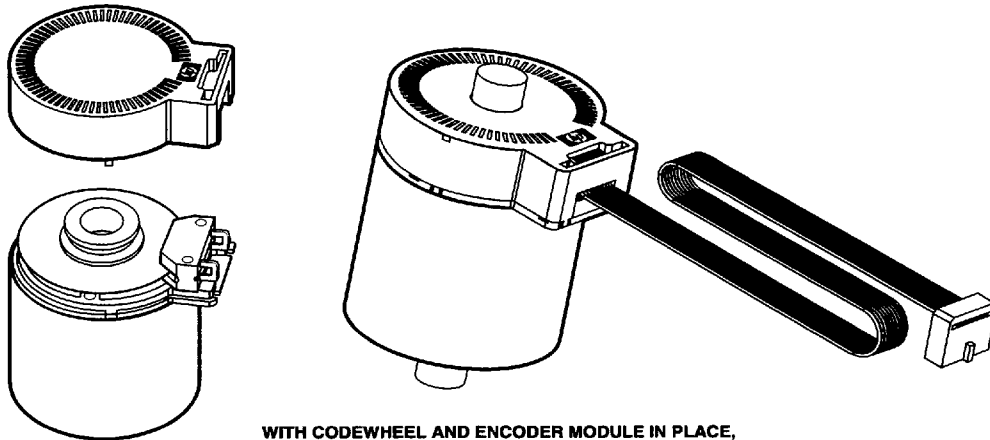

**Ordering Information for 2CH and 3CH Encoder Modules
Encoders with Metal Codewheels (up to 100 Degree C.)**

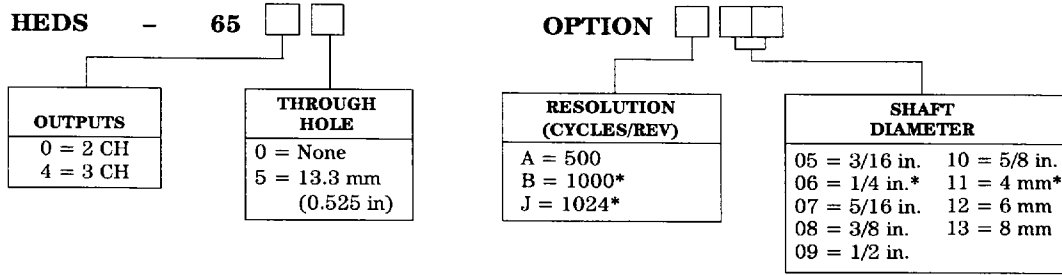

Encoders with Film Codewheels (up to 70 Degree C.)

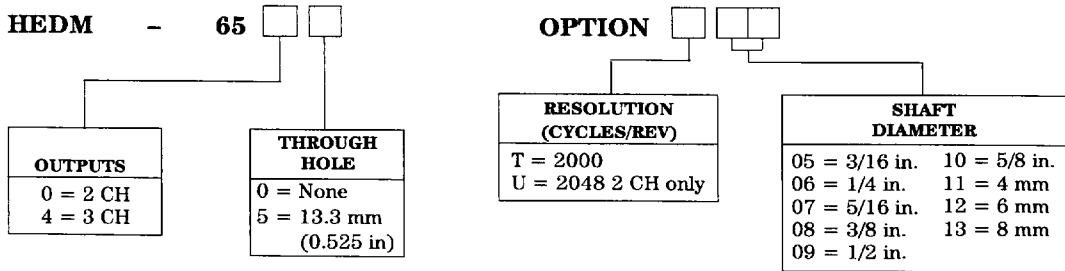

**Ordering Information for 2CH and 3CH Encoders Module with Line Driver
Encoders with Metal Codewheels (up to 100 Degree C.)**

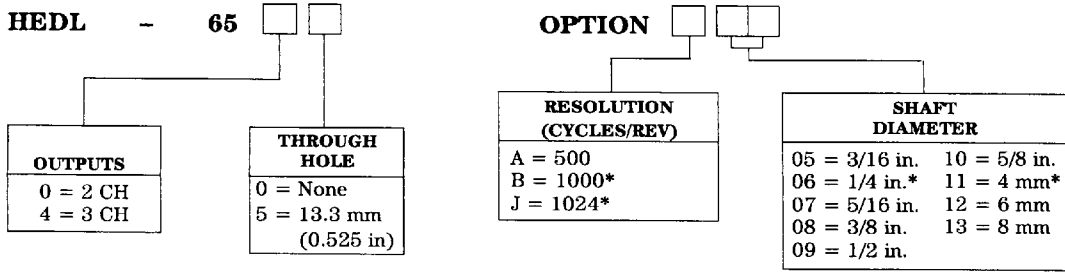

Encoders with Film Codewheels (up to 70 Degree C.) for 2000 CPR and 2048 CPR

Part Number	Encoder Module with Line Driver Description	Available Shaft Diameter
HEDL-6560#TXX	2 Ch. 2000 CPR encoder module with no through hole	Please refer to HEDS-65XX data sheet
HEDL-6561#TXX	2 ch. 2000 CPR encoder module with through hole	
HEDL-6560#UXX	2 ch, 2048 CPR encoder module with no through hole	
HEDL-6561#UXX	2 ch. 2048 CPR encoder module with through hole	
HEDL-6564#TXX	3 ch. 2000 CPR encoder module with no through hole	
HEDL-6565#TXX	3 ch. 2000 CPR encoder module with through hole	

*This is a popular option with short lead time.

Ordering Information for HEDS-65XX Centering Tools

HEDS-6510 OPTION 0

SHAFT DIAMETER	
05 = 3/16 in.	10 = 5/8 in.
06 = 1/4 in.	11 = 4 mm
07 = 5/16 in.	12 = 6 mm
08 = 3/8 in.	13 = 8 mm
09 = 1/2 in.	

Ordering Information for HEDS-65XX Codewheel

Gapping Tool

HEDS-6511