

PLEASE CHECK WWW.MOLEX.COM FOR LATEST PART INFORMATION

Part Number: [0387207407](#)
Status: **Active**
Description: 9.53mm (.375") Pitch Beau™ PCB Terminal Strip, with Mounting Ends, 7 Circuits, with Screw Clamp Washer

Documents:

[3D Model](#) [Product Specification PS-38710-001 \(PDF\)](#)
[Drawing \(PDF\)](#) [RoHS Certificate of Compliance \(PDF\)](#)

General

Product Family	Terminal Blocks
Series	38720
Application	Wire-to-Board
Component Type	One Piece
Product Name	Fixed Mount Barrier
Type	Barrier Strip

Physical

Circuits (Loaded)	7
Circuits (maximum)	7
Color - Resin	Black
Entry Angle	Horizontal
Lock to Mating Part	None
Material - Metal	Brass
Material - Plating Mating	Tin
Material - Plating Termination	Tin
Material - Resin	Polyester
Number of Rows	1
Orientation	Horizontal
PC Tail Length (in)	0.190 In
PC Tail Length (mm)	4.80 mm
PCB Retention	Yes
PCB Thickness Recommended (in)	0.125 In
PCB Thickness Recommended (mm)	3.18 mm
Panel Mount	No
Pitch - Mating Interface (in)	0.375 In
Pitch - Mating Interface (mm)	9.53 mm
Pitch - Term. Interface (in)	0.375 In
Pitch - Term. Interface (mm)	9.53 mm
Plating min: Mating (µin)	150
Plating min: Mating (µm)	3.75
Plating min: Termination (µin)	150
Plating min: Termination (µm)	3.75
Polarized to Mating Part	No
Shrouded	Dual-Barrier
Stackable	No
Surface Mount Compatible (SMC)	No
Temperature Range - Operating	-40°C to +130°C
Wire Size AWG	12, 14, 16, 18, 20, 22
Wire Size mm²	0.50 - 2.50

Electrical

Current - Maximum per Contact	25A
Voltage - Maximum	300V

Solder Process Data

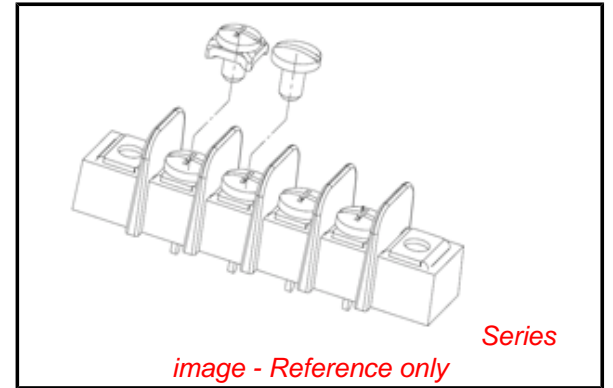

EU RoHS

**ELV and RoHS
Compliant**
REACH SVHC
 Not Reviewed
Halogen-Free
Status
 Not Reviewed

China RoHS



**Need more information on product
environmental compliance?**

Email productcompliance@molex.com
 For a multiple part number RoHS Certificate of Compliance, [click here](#)

Please visit the [Contact Us](#) section for any non-product compliance questions.

Search Parts in this Series

[38720Series](#)

Mates With

N/A

Lead-free Process Capability

Wave Capable (TH only)

Material Info

Old Part Number

72507-50

Reference - Drawing Numbers

Product Specification

PS-38710-001

Sales Drawing

SD-38720-001

This document was generated on 04/23/2010

PLEASE CHECK WWW.MOLEX.COM FOR LATEST PART INFORMATION

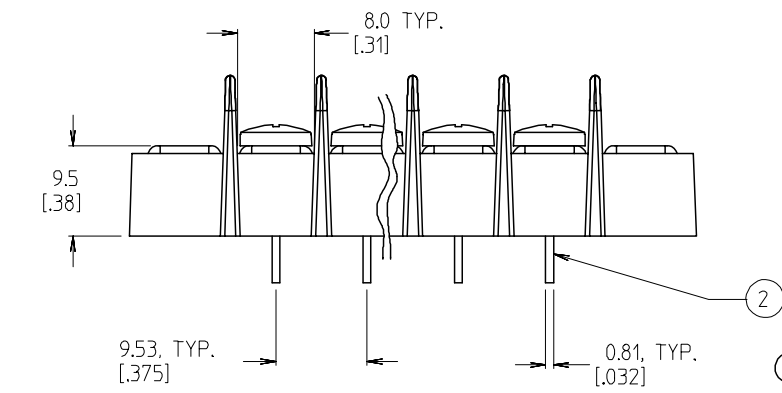
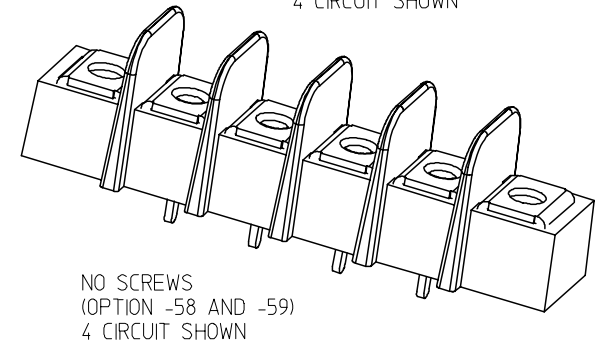
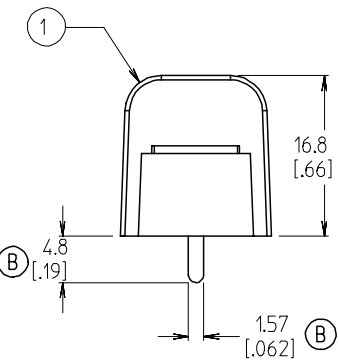
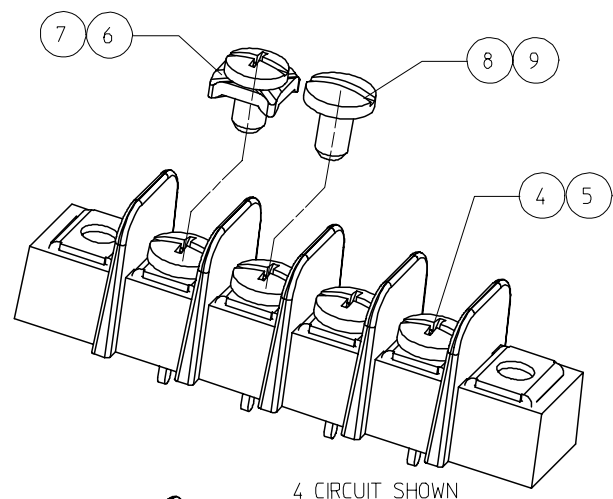

NOTES:

1. MATERIAL: SEE TABLE
2. FINISHES: SEE TABLE
3. INCH DIMENSIONS ARE IN BRACKETS [XXX].
4. REFER TO SD-38120-001 FOR IMPRINTING OPTIONS 10A AND 11A.
5. REFER TO SD-38120-007 FOR IMPRINTING OPTION 12A.
6. "XX" REFERS TO THE QUANTITY OF CIRCUITS.
7. ALL COMPONENTS ARE ROHS COMPLIANT.

11	XX	#6-32 WRDY W/WASH SCR (-47,-50)	STEEL	ZN, CLEAR CHROMATE
10	XX	#6-32 PH/SLOT WRDY SCR (OPT -47)	STEEL	ZN, CLEAR CHROMATE
9	XX	#6-32 SLOTTED SCREW (OPT -56)	STAINLESS STEEL	PASSIVATE
8	XX	#6-32 SLOTTED SCREW (OPT -45)	STEEL	ZN, CLEAR CHROMATE
7	XX	#6-32 PH/SL W/WASH SCR (-49,-50)	BRASS	NICKEL
6	XX	#6-32 PH/SL W/WASH SCR (OPT -50)	STEEL	ZN, CLEAR CHROMATE
5	XX	#6-32 PH/SLOTTED SCREW (OPT -49)	BRASS	NICKEL
4	XX	#6-32 PH/SLOTTED SCREW (STD)	STEEL	ZN, CLEAR CHROMATE
3	2	MOUNTING PLATE	BRASS	NICKEL
2	XX	TERMINAL	BRASS	BRT.TIN/CU
1	1	INSULATOR, SINGLE ROW	PBT	BLACK
ITEM	QTY.	DESCRIPTION	MATERIAL	FINISH

ADD. MAT. NO. EC NO: ETC2007-0166 DRW: NCLYORK 2006/10/19 CHKD: JMACEIL 2006/10/20 APPR: JMACEIL 2006/10/20	QUALITY SYMBOLS ▽=0 ▽=0	GENERAL TOLERANCES (UNLESS SPECIFIED)		DIMENSION STYLE	SCALE	DESIGN UNITS	THIRD ANGLE PROJECTION
		mm	INCH	MM/IN	2:1	INCH	
REV	DESCRIPTION	4 PLACES	± ---	± ---	DRAWN BY	DATE	TITLE
		3 PLACES	± ---	± .005	W. HOWARD	2003/10/16	
REV	DESCRIPTION	2 PLACES	± 0.13	± .01	CHECKED BY	DATE	MOLEX INCORPORATED
		1 PLACE	± 0.3	± ---	R. KEMP	2003/10/16	
REV	DESCRIPTION	ANGULAR ± 2 °		APPROVED BY	DATE	DOCUMENT NO.	SHEET NO.
		DRAFT WHERE APPLICABLE MUST REMAIN WITHIN DIMENSIONS		P. WALTZ	2003/10/16		
SIZE	B	THIS DRAWING CONTAINS INFORMATION THAT IS PROPRIETARY TO MOLEX INCORPORATED AND SHOULD NOT BE USED WITHOUT WRITTEN PERMISSION					

MATERIAL NO. (OPT 12A)	MATERIAL NO. (OPT 11A)	MATERIAL NO. (OPT 10A)	MATERIAL NO. (OPT -59)	MATERIAL NO. (OPT -58)	MATERIAL NO. (OPT -56)	MATERIAL NO. (OPT -50)	MATERIAL NO. (OPT -49,-50)	MATERIAL NO. (OPT -49)	MATERIAL NO. (OPT -47,-50)	MATERIAL NO. (STD)	NUMBER OF CIRCUITS 'XX'
					38729-0659	38729-0791	38729-1381	38729-6802		38729-6201	01
		38729-1039		38729-0750	38729-0791	38729-0117	38729-6803	38729-6802		38729-6202	02
38729-0872	38729-0025	38729-0014			38729-0117	38729-7403		38729-6803	38729-8603	38729-6203	03
		38729-0940	38729-0945		38729-0839	38729-7404	38729-1159	38729-6804		38729-6204	04
38729-0256		38729-0346			38729-1253	38729-7405	38729-1382	38729-6805		38729-6205	05
			38729-0400	38729-0386	38729-0980	38729-7406	38729-1383	38729-6806		38729-6206	06
		38729-0423	38729-0407	38729-0435	38729-0440	38729-7407		38729-6807		38729-6207	07
38729-0497				38729-0508	38729-0532	38729-7408		38729-6808		38729-6208	08
		38729-0548		38729-0560		38729-7409		38729-6809		38729-6209	09
		38729-1011	38729-0598	38729-0598		38729-7410		38729-6810		38729-6210	10
					38729-1252	38729-7411				38729-6211	11
		38729-0720			38729-0735	38729-7412		38729-6812		38729-6212	12
				38729-0809		38729-7413				38729-6213	13
				38729-0004		38729-7414		38729-6814		38729-6214	14
										38729-6215	15
										38729-6216	16
										38729-6217	17
										38729-6218	18
										38729-6219	19
										38729-6220	20
										38729-6221	21
										38729-6222	22
										38729-6223	23
										38729-6224	24
										38729-6225	25
										38729-6226	26

NUMBER OF CIRCUITS 'XX'	DIM. 'A'		DIM. 'B'		DIM. 'C'		DIM. 'D'	
01	30.7	[.121]	-	-	19.1	[.75]	11.6	[.46]
02	40.1	[.158]	9.53	[.375]	28.6	[1.13]	21.1	[.83]
03	49.7	[.196]	19.05	[.750]	38.1	[1.50]	30.6	[1.21]
04	59.2	[.233]	28.58	[1.125]	47.6	[1.88]	40.1	[1.58]
05	68.7	[.271]	38.10	[1.500]	57.2	[2.25]	49.7	[1.96]
06	78.2	[.308]	47.63	[1.875]	66.7	[2.63]	59.2	[2.33]
07	87.8	[.346]	57.15	[2.250]	76.2	[3.00]	68.7	[2.71]
08	97.3	[.383]	66.68	[2.625]	85.7	[3.38]	78.2	[3.08]
09	106.8	[.421]	76.20	[3.000]	95.3	[3.75]	87.8	[3.46]
10	116.3	[.458]	85.73	[3.375]	104.8	[4.13]	97.3	[3.83]
11	125.9	[.496]	95.25	[3.750]	114.3	[4.50]	106.8	[4.21]
12	135.4	[.533]	104.78	[4.125]	123.8	[4.88]	116.3	[4.58]
13	144.9	[.571]	114.30	[4.500]	133.4	[5.25]	125.9	[4.96]
14	154.4	[.608]	123.83	[4.875]	142.9	[5.63]	135.4	[5.33]
15	164.0	[.646]	133.35	[5.250]	152.4	[6.00]	144.9	[5.71]
16	173.5	[.683]	142.88	[5.625]	161.9	[6.38]	154.4	[6.08]
17	183.0	[.721]	152.40	[6.000]	171.5	[6.75]	164.0	[6.46]
18	192.5	[.758]	161.93	[6.375]	181.0	[7.13]	173.5	[7.21]
19	202.1	[.796]	171.45	[6.750]	190.5	[7.50]	192.5	[7.58]
20	211.6	[.833]	180.98	[7.125]	200.0	[7.88]	202.1	[7.96]
21	221.1	[.871]	190.50	[7.500]	209.6	[8.25]	211.6	[8.33]
22	230.6	[.908]	200.03	[7.875]	219.1	[8.63]	221.1	[8.71]
23	240.2	[.946]	209.55	[8.250]	228.6	[9.00]	230.6	[9.08]
24	249.7	[.983]	219.08	[8.625]	238.1	[9.38]	230.6	[9.08]
25	259.2	[10.21]	228.60	[9.000]	247.7	[9.75]	240.2	[9.46]
26	268.7	[10.58]	238.13	[9.375]	257.2	[10.13]	249.7	[9.83]



PTH PATTERN

SEE SHEET 1 EC NO: ETC2007-0166 DRW: NCLYORK 2006/10/19 CHKD: JMACNEIL 2006/10/20 APPR: JMACNEIL 2006/10/20	QUALITY SYMBOLS ▽=0 ▽=0	GENERAL TOLERANCES (UNLESS SPECIFIED) mm INCH 4 PLACES ± --- ± --- 3 PLACES ± --- ± .005 2 PLACES ± 0.13 ± .01 1 PLACE ± 0.3 ± --- ANGULAR ± 2 °	DIMENSION STYLE MM/IN DRAWN BY: W. HOWARD DATE: 2003/10/16 CHECKED BY: R. KEMP DATE: 2003/10/16 APPROVED BY: P. WALTZ DATE: 2003/10/16	SCALE 2:1 DESIGN UNITS INCH THIRD ANGLE PROJECTION	TITLE 9.53MM [.375] SR BTS, PC ASSY
	MATERIAL NO. SEE CHART	DOCUMENT NO. MOLEX INCORPORATED SD-38720-001	SHEET NO. 2 OF 2		
	DRAFT WHERE APPLICABLE MUST REMAIN WITHIN DIMENSIONS	SIZE B	THIS DRAWING CONTAINS INFORMATION THAT IS PROPRIETARY TO MOLEX INCORPORATED AND SHOULD NOT BE USED WITHOUT WRITTEN PERMISSION		