

**PLEASE CHECK WWW.MOLEX.COM FOR LATEST PART INFORMATION**

**Part Number:** [0473140052](#)  
**Status:** **Active**  
**Description:** 1.00mm (.039") Pitch 54mm ExpressCard\* Header, Top Mount, with Push-Push Mechanism, Lead free

**Documents:**

[3D Model](#) [Product Specification PS-47202-001 \(PDF\)](#)  
[Drawing \(PDF\)](#) [RoHS Certificate of Compliance \(PDF\)](#)

**General**

Product Family	Memory Card Sockets
Series	47314
Button Type	Push-Push
Comments	0.5mm (.020") Stand-off Height
Component Type	Header/Socket (Host)
Product Name	ExpressCard*
Type	N/A

**Physical**

Card Detection Switch	N/A
Circuits (Loaded)	26
Circuits (maximum)	26
Durability (mating cycles max)	10,000
Ejector Button Side	No Ejector Button Present
Entry Angle	90° Angle
Keying to Mating Part	Yes
PCB Locator	Yes
PCB Mounting Side	Normal
PCB Retention	Yes
Packaging Type	Embossed Tape on Reel
Pitch - Mating Interface (in)	0.039 In
Pitch - Mating Interface (mm)	1.00 mm
Pitch - Term. Interface (in)	0.039 In
Pitch - Term. Interface (mm)	1.00 mm
Ports	1
Surface Mount Compatible (SMC)	Yes
Temperature Range - Operating	0°C to +55°C

**Electrical**

Current - Maximum per Contact	0.75A
Shielded	No
Voltage - Maximum	3.3V DC
Voltage Key	N/A

**Solder Process Data**

Duration at Max. Process Temperature (seconds)	5
Lead-free Process Capability	Reflow Capable (SMT only)
Max. Cycles at Max. Process Temperature	2
Process Temperature max. C	260

**Material Info**

**Reference - Drawing Numbers**

Packaging Specification	PK-47314-001
Product Specification	PS-47202-001
Sales Drawing	SD-47314-001

\* ExpressCard is trademark, or registered trademark of PCMCIA

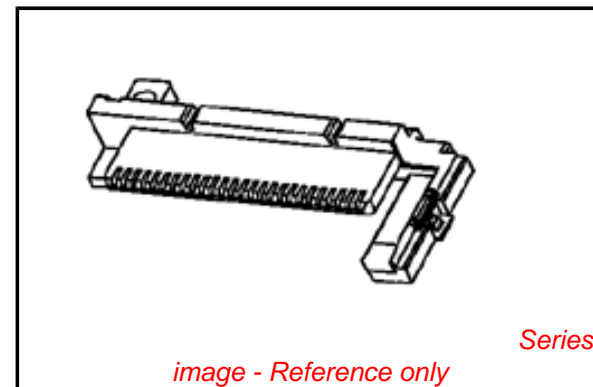

**EU RoHS**

**ELV and RoHS  
Compliant**  
**REACH SVHC  
Contains SVHC: No**  
**Halogen-Free  
Status**

**China RoHS**



**Need more information on product  
environmental compliance?**

Email [productcompliance@molex.com](mailto:productcompliance@molex.com)  
For a multiple part number RoHS Certificate of Compliance, [click here](#)

Please visit the [Contact Us](#) section for any non-product compliance questions.

**Search Parts in this Series**

[47314Series](#)

**Mates With**

[ExpressCard\\* Module](#)

**Use With**

[473149053 Top Mount 54mm Ejector](#)

This document was generated on 06/01/2010

**PLEASE CHECK [WWW.MOLEX.COM](http://WWW.MOLEX.COM) FOR LATEST PART INFORMATION**

10 9 8 7 6 5 4 3 2 1

F

E

D

C

B

A

F

E

D

C

B

A

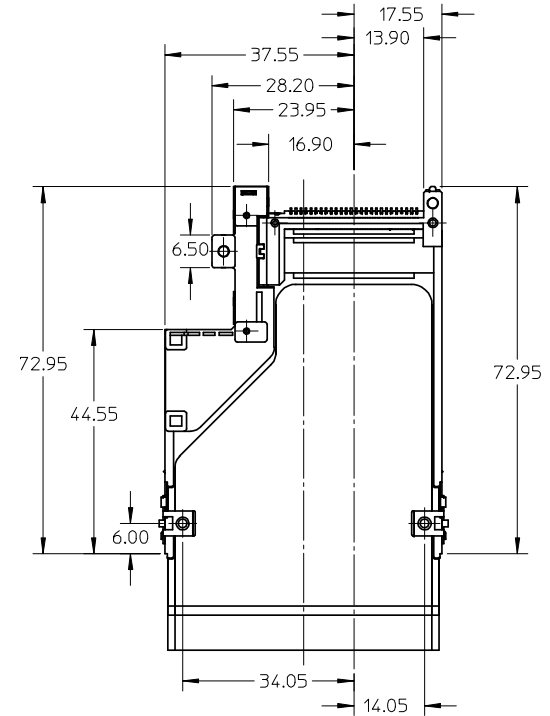
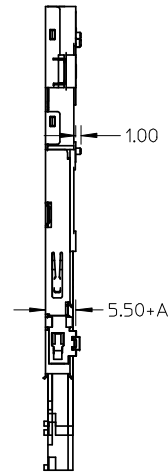
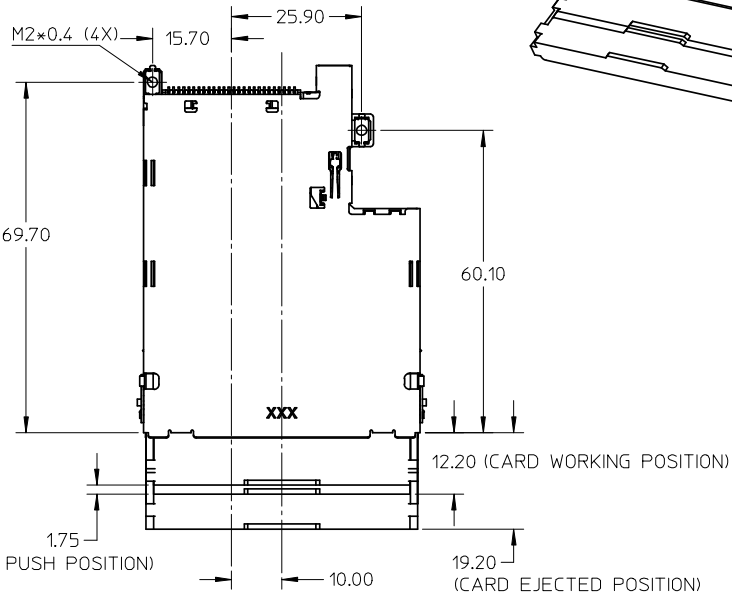
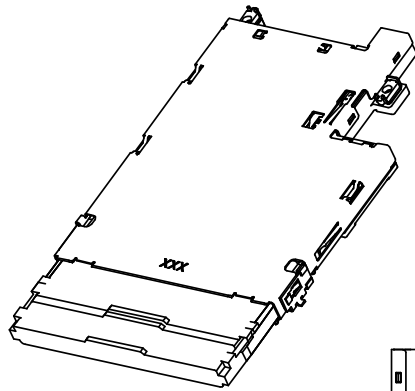
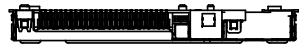

NOTES:

1. COMPONENT:

HEADER: SHEET 2

EJECTOR: SHEET 3

2. PCB LAYOUT PLEASE REFER TO SHEET 4,

3. COPLANARTY OF HEADER FOR SMT SOLDER TAILS

TO BE 0.1mm MAXIMUM,

4. PRODUCT SPECIFICATION PLEASE REFER TO PS-47202-001,

5. SCREW FASTENING TORQUE: 1.5kgf-cm MAXIMUM,

6. TRUE POSITION IS 0.15mm MAXIMUM BETWEEN SOLDER TAILS,

7. NON-REFLOW PROCESS FOR CARD CAGE.

RELEASE IEC NO: SH2008-0202 DRW: F YANG05 CHKD: APPR: H WANG 2007/12/03 2007/12/04 2007/12/28	QUALITY SYMBOLS ▽=0 ◻=0	GENERAL TOLERANCES (UNLESS SPECIFIED)		DIMENSION STYLE MM ONLY		SCALE 1:1	DESIGN UNITS METRIC	THIRD ANGLE PROJECTION			
		4 PLACES ± --- ± ---	3 PLACES ± --- ± ---	2 PLACES ± 0.25 ± ---	1 PLACE ± 0.3 ± ---	DRAWN BY R. BIAN	DATE 2005/08/05	TITLE EXPRESSCARD TOP MOUNT WITH PUSH-PUSH MECHANISM (CARD PUSH)			
		ANGULAR ± 3 °				APPROVED BY HARVEY WANG	DATE 2005/08/05	MOLEX INCORPORATED			
		DRAFT WHERE APPLICABLE MUST REMAIN WITHIN DIMENSIONS				MATERIAL NO. N/A	DOCUMENT NO. SD-47314-001	SHEET NO. 1 OF 4			
				SIZE A3	THIS DRAWING CONTAINS INFORMATION THAT IS PROPRIETARY TO MOLEX INCORPORATED AND SHOULD NOT BE USED WITHOUT WRITTEN PERMISSION						

9 8 7 6 5 4 3 2 1

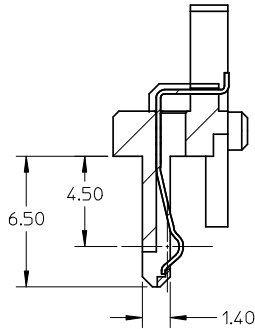
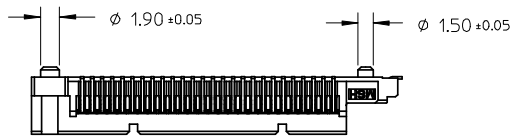
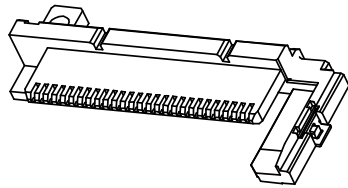

SECTION Z-Z  
SCALE:4:1

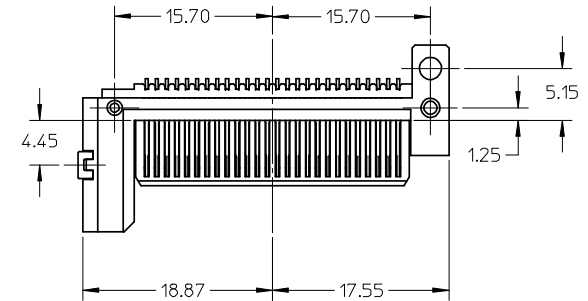
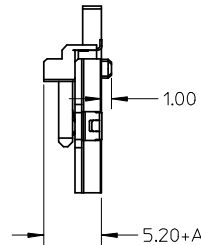
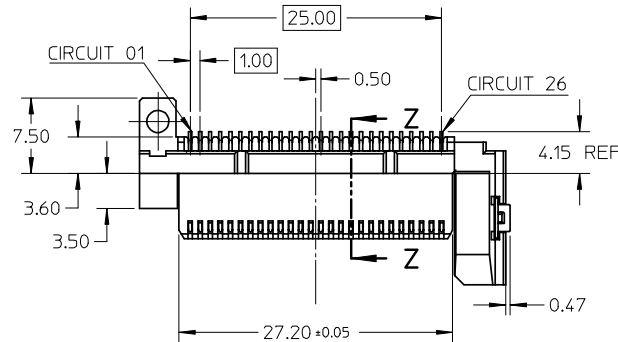

NOTES:

1. MATERIAL:

HOUSING: LIQUID CRYSTAL POLYMER, GLASS FILLED, UL94V-0, COLOUR: BLACK.  
 TERMINAL: PHOSPHOR BRONZE  
 FITTING NAIL: PHOSPHOR BRONZE

2. FINISH:

TERMINAL: SELECTIVE GOLD(Au) IN CONTACT AREA,  
 THICKNESS: 0.3 MICROMETER MINIMUM  
 SELECTIVE PURE TIN ON SOLDER TAIL AREA.  
 THICKNESS: 1.5 MICROMETER MINIMUM  
 UNDERPLATING: NICKEL(Ni) OVERALL

3. COPLANARITY AT SOLDER TAIL TO BE 0.1mm MAXIMUM,

4. DESIGN BASED ON EXPRESSCARD STANDARD;

5. APPLICABLE EJECTOR PLEASE SEE TABLE;

6. PRODUCT SPECIFICATION PLEASE REFER TO PS-47202-001;

7. THE PART COMPLIANT TO RoHS DIRECTIVE 2002/95/EC AND ELV 2000/53/EC.

RELEASE IEC NO: SH2008-0202 DRAWN: YANG05 2007/12/03 CHKD: 2007/12/04 APPR: HWANG 2007/12/28	QUALITY SYMBOLS ▽=0 ◻=0	GENERAL TOLERANCES (UNLESS SPECIFIED)		DIMENSION STYLE MM ONLY		SCALE NTS	DESIGN UNITS METRIC	THIRD ANGLE PROJECTION			
		4 PLACES ± --- ± ---	3 PLACES ± --- ± ---	mm	INCH	DRAWN BY R. BIAN	DATE 2005/08/05	TITLE EXPRESSCARD TOP MOUNT WITH PUSH-PUSH MECHANISM (CARD PUSH)			
		2 PLACES ± 0.25 ± ---	1 PLACE ± 0.3 ± ---	ANGULAR ± 3 °		APPROVED BY HARVEY WANG	DATE 2005/08/05	MOLEX INCORPORATED			
		DRAFT WHERE APPLICABLE MUST REMAIN WITHIN DIMENSIONS		SEE TABLE		MATERIAL NO.	DOCUMENT NO.	SHEET NO. 2 OF 4			

47314-0052	0.50 MM	47314-9053
PART NO.	A (STAND OFF HEIGHT)	APPLICABLE EJECTOR

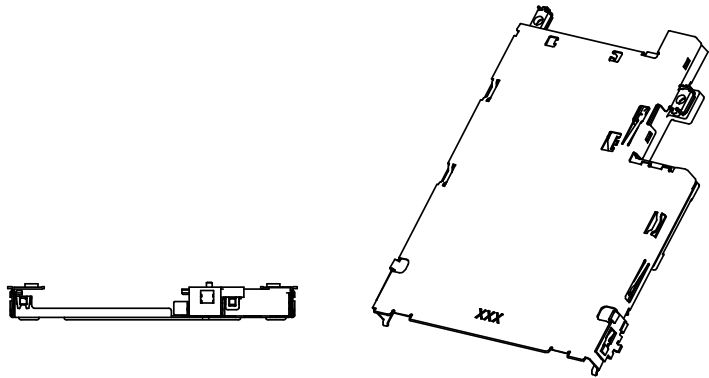

NOTES:

1. MATERIAL:

- SHELL: STAINLESS STEEL
- STAND OFF: STAINLESS STEEL
- NUT: STAINLESS STEEL
- COIL SPRING: STEEL WIRE
- CAM SLIDER: NYLON 46, GLASS FILLED, UL94V-0, COLOUR: BLACK
- SLIDER HOUSING: NYLON 46, GLASS FILLED, UL94V-0, COLOUR: BLACK
- CAM PIN: STAINLESS STEEL

- 2. THIS SLOT TO BE COMPATIBLE BOTH 34mm CARD AND 54mm CARD;
- 3. THE EJECTOR MECHANISM TO BE ASSEMBLED BASE ON 34mm CARD CENTER LINE;
- 4. APPLICABLE HEADER PLEASE SEE TABLE;
- 5. PRODUCT SPECIFICATION PLEASE REFER TO PS-47202-001;
- 6. THE PART COMPLIANT TO RoHS DIRECTIVE 2002/95/EC AND ELV 2000/53/EC.

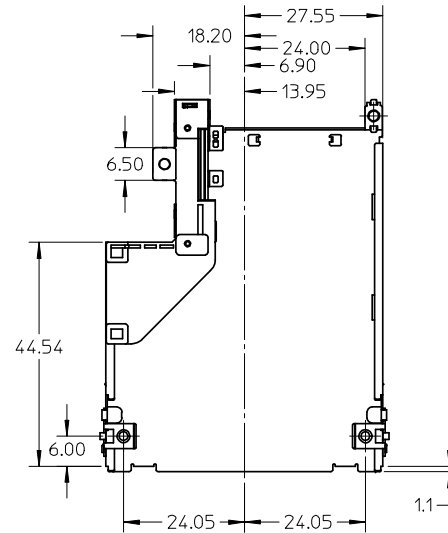
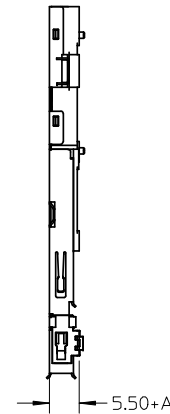
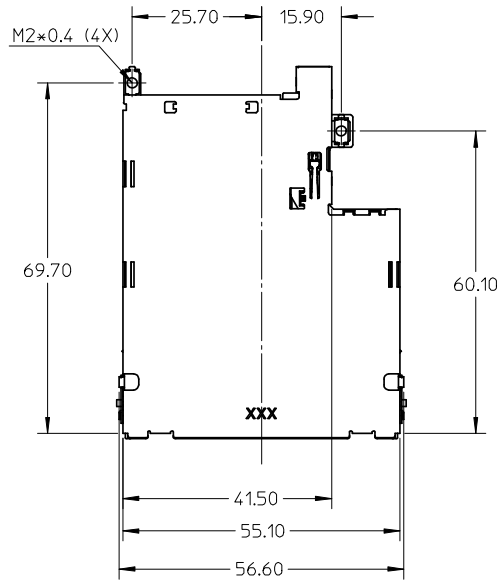

RELEASE EC NO: SHZ008-0202 DRW: F YANG05 CHKD: APPR: H WANG 2007/12/03 2007/12/04 2007/12/28	DESCRIPTION QUALITY SYMBOLS ▽=0 ◻=0	GENERAL TOLERANCES (UNLESS SPECIFIED)		DIMENSION STYLE MM ONLY		SCALE NTS	DESIGN UNITS METRIC	THIRD ANGLE PROJECTION	
			mm	INCH	DRAWN BY R. BIAN	DATE 2005/08/05	TITLE EXPRESSCARD TOP MOUNT WITH PUSH-PUSH MECHANISM (CARD PUSH)		
		4 PLACES	± ---	± ---	CHECKED BY	DATE	MOLEX MOLEX INCORPORATED		
		3 PLACES	± ---	± ---	APPROVED BY HARVEY WANG		DATE 2005/08/05	DOCUMENT NO. SD-47314-001	
2 PLACES	± 0.25	± ---	MATERIAL NO.		DATE	SHEET NO. 3 OF 4			
1 PLACE	± 0.3	± ---	DRAFT WHERE APPLICABLE MUST REMAIN WITHIN DIMENSIONS		DATE	THIS DRAWING CONTAINS INFORMATION THAT IS PROPRIETARY TO MOLEX INCORPORATED AND SHOULD NOT BE USED WITHOUT WRITTEN PERMISSION			
ANGULAR ± 3 °		SEE TABLE							

47314-9053	0.50 MM	47314-0052
PART NO.	A (STAND OFF HEIGHT)	APPLICABLE HEADER

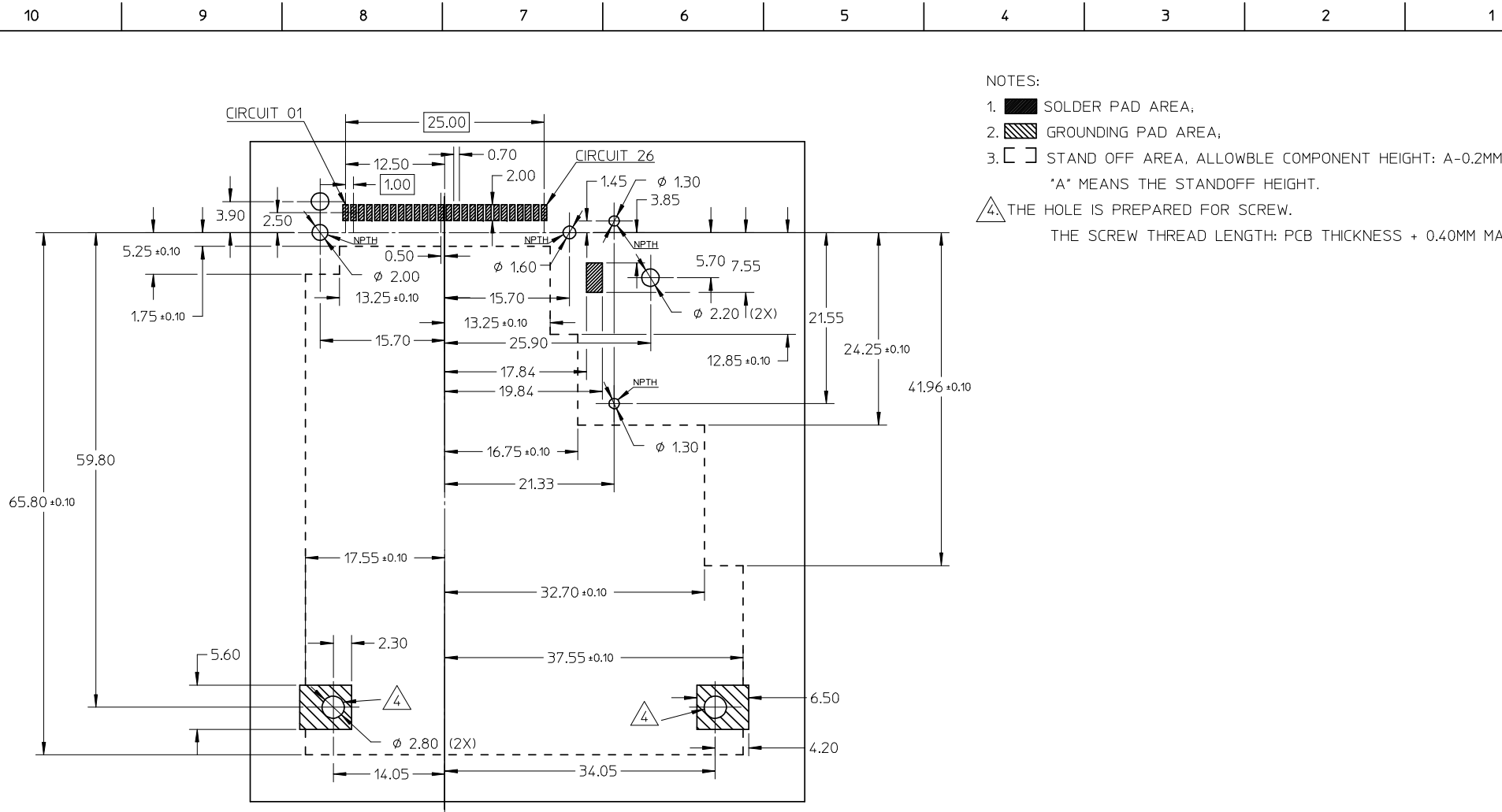

NOTES:

1. SOLDER PAD AREA;
2. GROUNDING PAD AREA;
3. STAND OFF AREA, ALLOWBLE COMPONENT HEIGHT: A-0.2MM, 'A' MEANS THE STANDOFF HEIGHT.
4. THE HOLE IS PREPARED FOR SCREW.  
THE SCREW THREAD LENGTH: PCB THICKNESS + 0.40MM MAX.

RELEASE EC NO: SH2008-0202 DRWN: FYANG05 CHKD: APPR: HWANG 2007/12/03 2007/12/04 2007/12/28	QUALITY SYMBOLS = 0 = 0	GENERAL TOLERANCES (UNLESS SPECIFIED)		DIMENSION STYLE	SCALE	DESIGN UNITS	THIRD ANGLE PROJECTION	
				MM ONLY	NTS	METRIC		
				DRAWN BY	DATE	TITLE		
				4 PLACES	± ---	± ---	EXPRESSCARD TOP MOUNT WITH PUSH-PUSH MECHANISM (CARD PUSH)	
		3 PLACES	± ---	± ---	MOLEX INCORPORATED			
		2 PLACES	± 0.25	± ---	DOCUMENT NO.			
		1 PLACE	± 0.3	± ---	SD-47314-001			
		ANGULAR ± 3 °		APPROVED BY		DATE		
		DRAFT WHERE APPLICABLE MUST REMAIN WITHIN DIMENSIONS		HARVEY WANG		2005/08/05		
				MATERIAL NO.		SHEET NO.		
				N/A		4 OF 4		
				THIS DRAWING CONTAINS INFORMATION THAT IS PROPRIETARY TO MOLEX INCORPORATED AND SHOULD NOT BE USED WITHOUT WRITTEN PERMISSION				