



ICM205B VGA/QVGA CMOS image sensor with digital YUV output

Data Sheet V1.3

IC Media Corporation

545 East Brokaw Road
San Jose, CA 95112, U.S.A.
Phone: (408) 451-8838
Fax: (408) 451-8839
Email: Sales@IC-Media.Com
Web Site: www.ic-media.com

IC Media Technology Corporation

6F, No. 61, ChowTze Street., NeiHu District
Taipei, Taiwan, R.O.C.
Phone: 886-2-2657-7898
Fax: 886-2-2657-8751
Email: Ap.Sales@IC-Media.Com.tw
Web Site: www.ic-media.com.tw

Important notice: This document contains information of a new product. IC Media Corp. reserves the right to make any changes without further notice to any product herein to improve design, function or quality and reliability. No responsibility is assumed by IC Media Corp. for its use, nor for any infringements of patents of third parties that may result from its use.



Features

- 307,200 (640x480) pixels, VGA format, used with 1/4" optical system
- Correlated double sampling
- On-chip 9-bit ADC
- On-chip digital signal processing
 - Real-time color interpolation
 - Programmable/Automatic exposure control
 - Programmable/Automatic white balancing and color correction
 - Programmable sharpening control
 - Programmable color saturation control
 - Programmable gamma correction
 - Programmable brightness correction
 - Programmable hue correction
 - Programmable contrast correction
 - Programmable anti-flickering (50Hz, 60Hz or off, like outdoor)
 - Programmable media filter.
- Progressive readout
- Video mode and single frame mode
- Output data format: 8/16-bit YCbCr, 24-bit RGB, 16-bit RGB, 8-bit raw data
- Output modes: VGA and Sub-sampling QVGA/QQVGA, programmable
- Input/output interface: SIF
- Power down mode
- Automatic optical black compensation
- Left-Right Mirror image
- Up-down Mirror image
- Single power supply, 3.3V +/- 0.15V



General Description

This is a single-chip digital color imaging device. It incorporates a 640 x 480 sensor array operating at max. 30 frames per second in progressive manner. Each pixel is covered by a color filter, which formed a so-called Bayer pattern. Correlated double sampling is performed by the internal ADC and timing circuitry.

Depending on the brightness of the scene, the raw data can be adjusted by the digital gain for all pixels, or be adjusted separately for the 4 Bayer pattern pixels. This is done either by the built-in automatic exposure control circuit, or can be done manually by the external CPU via serial bus control.

The data are then processed by the color interpolation module so that each pixel will get a complete set of RGB values. To correct or enhance color, automatic white balance circuit is built-in. The user may perform white balancing and color correction manually by external CPU via serial bus too. Color saturation control is programmable via serial bus, if user is not satisfied with the default settings

At the final stage, the gamma correction can also be performed, in addition to default value. The output formats include 8/16-bit YCbCr, 24-bit, 16-bit RGB, and 8-bit raw data which can be fed to other DSP, color processing, or compression chips.



Application

- Video cellular phone
- PDA
- Digital camcorder
- Digital still camera
- Video phone
- Video conferencing
- Video mail
- PC camera
- Security system
- Visual toy
- Industrial image capture/analysis
- Environment monitor system

Key Parameters

- Number of Active Pixels: 640 x 480
- Number of Physical Pixels: 650 x 490
- Frame Rate: from 30 to 1 fps, flexible
- Pixel Size: 6.0 μm x 6.0 μm
- Sensor Area: 3.84 mm x 2.88 mm (for 1/4" lens)
- Main Clock Frequency: 3 to 24 MHz
- Exposure Time: 64 μs (@ 30 fps, 1 line, 24 MHz) ~ 125 s (@ 1 fps, 65535 lines, 24 MHz), every step: 64 μs
- Digital gain 1x - 64x @ 2^N for all pixels
- RGB gain from 1/256 to 8 in step of 1/256 for individual Bayer pattern pixels
- S/N Ratio: 45 dB @ 75% Saturation
- Target Power Supply: 3.3V +/- 0.15V
- Target Power Requirement: <75mW (@ 15fps, 12 MHz, 2.8V),
- Package: Shrunken Plastic LCC48 (ICM205Bsa)



Pin #	Name	Class*	Function Descriptions
13	Xin	A, I	Crystal in
14	Xout	A, O	Crystal out
2	PCLK	D, O	Pixel clock output
21	TEST	D, I, N	Test Mode Input Pin
22	SYNCMODE	D, I, N	Sync. Mode. 0: External Sync, 1: Internal Sync
23	PWRDOWN	D, I,U	Power Down Mode. 0:Enable 1:Disable
25	Enable	D, I, U	Data Output . 0:Disble 1:Enable
24	I2CA	D, I, N	LSB of serial bus address. 0: Device ID address 0x20 1: Device ID address 0x21
20	MSSEL	D, I, U	Serial bus master/slave selection. 0: Slave 1: Master
26	SCLOCK	D, I/O	Serial bus clock
27	SDATA	D, I/O	Serial bus data
16	GNDS	P	Substrate GND
18	RSET	A, I	Resistor to ground 51 K Ω @ Clock = 24Mhz
10	RSTN	D, I, U	Chip reset, active low
45, 46, 47, 48, 1, 3, 4, 9	DOUT[7:0] (msb:lsb)	D, O	Sensor Data output[7:0]
28, 30, 34, 35, 36, 37, 38, 39	DOUT[15:8] (msb:lsb)	D, I/O	1) Input: Test Data Input 2) Sensor Data output[15:8]
41	HSYNC	D, I/O	Horizontal sync signal
42	VSYNC	D, I/O	Vertical sync signal
40	BLANK	D, O	Video blank signal
15	RAMP	A, O	Analog ramp output
11, 33	VDDA	P	Analog power
12, 32	GNDA	P	Analog ground
6, 19, 43	VDDD, VDDK	P	Digital power
5, 17, 44	GNDD GNDK	P	Digital ground
7, 31	VDDO	P	Pad power
8, 29	GNDO	P	Pad ground

Class Code:

A - Analog signal, D - Digital signal, I - Input, O - Output, P - Power or ground,
U - Internal pull-up, N - Internal pull-down



Functional Description

Image Array

The image array consists of 640x480 pixels. Each pixel has a light sensitive photo diode and a set of control and transfer transistors. At the beginning of the cycle, a row of pixels are pre-charged to its maximum value. Then they are exposed to light for several lines worth of time and sampled by the ADC. Correlated double sampling (CDS) is performed by subtracting the reset value (sampled right before sampling the signal) from the signal value. The purpose of CDS is to eliminate the point-wise fixed pattern noise (FPN). The output of CDS is approximately proportional to the amount of received light, ranging from 0 to 255.

Color Filter

Each pixel is covered by a color filter. They form the Bayer Pattern as shown in Figure 2. (Row 0, Column 0) is covered by a Red filter, (Row 0, Column 1) and (Row 1, Column 0) by Green filters, and (Row 1, Column 1) by a Blue filter. Since each pixel only gets part of the frequency band, the data need further processing (i.e., color interpolation and color correction) in order to approximate the full visible spectrum.

R	G	R	G	R	G	R	G
G	B	G	B	G	B	G	B
R	G	R	G	R	G	R	G
G	B	G	B	G	B	G	B

Figure 2. Color filter Bayer pattern

Exposure and Gain Control

The brightness of the scene may change by a great amount that renders the captured image either over-exposed or under-exposed. To accommodate for different brightness, the user may change the exposure time by adjusting the AD_EXPOSE_TIMEH, and AD_EXPOSE_TIMEL. The exposure time is measured in terms of the time to read out one line of data, which is equal to 64 μs (assuming the line length is 770 @ 24 MHz). If the number of lines per frame is set at 520 (the default), the exposure time can vary from 1 to 519 lines.

50/60Hz anti-flickering control

To eliminate the flickering caused by the 50Hz or 60Hz light source normally found indoor, an anti-flickering control circuit is build in. The selection is between off and on. When it is on, then the selection is between 50 or 60Hz.



Auto Exposure

The Auto Exposure circuit control the Exposure Time, Digital Gain, and Anti-flickering function automatically. The following features are provided:

- . Disable/Enable AE
- . Disable/Enable Anti-flickering
- . Disable/Enable Digital Gain
- . Disable/Enable Fix Frame Rate
- . Adjustable Maximum/Minimum Frame Rate
- . Adjustable AE Target brightness value

The following registers are use to control these features:

0x3A (AD_AE_CTRL, Default = 7)

- bit 0 : Disable/Enable AE
- bit 1 : Disable/Enable Digital Gain
- bit 2 : Disable/Enable Anti-flickering
- bit 3 : Disable/Enable Fix Frame Rate

The default value enable AE, Anti-flickering, and Digital Gain.

0x3B (AD_AE_HIGH, AE Target value High Limit, Default = 0x65)

0x3C (AD_AE_LOW, AE Target value Low Limit, Default = 0x55)

Use AD_AEHIGH and AD_AELOW to set the target brightness of AE function.

0x3F, 0x40 (AD_MAXFH, Maximum Frame Height, Default = 0x1450)

AD_MAXFH set the minimum frame rate of AE .

0x41, 0x42 (AD_MINFH, Minimum Frame Height, Default = 0x208)

AD_MINFH set the maximum frame rate of AE .

0x44 (AD_AFSTEP, Anti-flickering Exposure Time Step, Default = 0x82)

Use AD_AFSTEP to setup 50 / 60HZ Anti-flickering step.

Color Interpolation

Since the raw data coming out the sensor array has only one of the R, G, or B value for each pixel, we need to perform interpolation to obtain a set of correlated RGB value for each pixel. The method used is based on a 3x3 interpolation window. The result of this operation is a data stream consisting of 24-bit RGB per pixel. After this step, the whole frame can be viewed as a color picture. However, since the RGB filters and the photodiode are not perfect, the RGB values may have different strength. In addition, there are some cross-talk among the RGB channels. That's why we need the color correction (or white balancing) step.



Auto White Balancing

Due to the different transparency and the overlapping spectrum response of the R, G, and B filters, the interpolated color may not be balanced. The Auto White Balancing performs the White Balance function automatically. The following registers are used to control the AWB function:

0x33 (AD_AWB_CTRL, Default = 3)

- 0 : Disable AWB
- 1 : Enable AWB with R,G,B range limited
- 3 : Enable AWB with no range limited

0x34 (AD_AWB_OVERFLOW, Default = 255)

Set the overflow value of the sampling pixel, if the sampling data is larger than AD_AWB_OVERFLOW, then it will not be used for AWB processing. The default value 255 means there is no limit on sampling data.

0x35 (AD_AWB_BRIGHT, Default = 0)

Set the minimum bright value of the sampling pixel, if the sampling data is less than AD_AWB_BRIGHT, then it will not be used for AWB processing. The default value 0 means there is no limit on sampling data.

When AWB function is disabled, the following registers are used to adjust the White Balance manually:

0x37 (AD_WB_RED, Default = 0x80)

Set the RED Gain manually.

0x38 (AD_WB_GREEN, Default = 0x80)

Set the GREEN Gain manually.

0x39 (AD_WB_BLUE, Default = 0x80)

Set the BLUE Gain manually.

Sharpening

The following registers are used to control the Sharpening function:

0x30 (AD_SHARP_CTRL, Default = 9)

- 0 : Disable Sharpening.
- 8 : Sharpen Weight = 0.5 (light Sharpening)
- 9 : Sharpen Weight = 1 (default)
- a : Sharpen Weight = 2
- b : Sharpen Weight = 3
- c : Sharpen Weight = 4
- d : Sharpen Weight = 5
- e : Sharpen Weight = 6
- f : Sharpen Weight = 7 (heavy Sharpening)

0x31 (AD_SHARP_HIGH, Default = 0x0a)

Sharpening High Tone Threshold.

0x32 (AD_SHARP_LOW, Default = 0x05)

Sharpening Low Tone Threshold.



Color saturation control

The color saturation can be enhanced by adjusting the Saturation Factor register 0x2D (AD_SATURATION, Default = 0x30).

The following examples show how to set the Saturation to 0, 1, 1.5, and 2:

- Saturation 0 : AD_SATURATION = 0x00, no color (B/W)
- 1 : AD_SATURATION = 0x20
- 1.5: AD_SATURATION = 0x30
- 2.0: AD_SATURATION = 0x40

Gamma Correction

To boost darker signal to match the video monitor characteristic, gamma correction are performed:

$$V_o = V_i^{1/\gamma}$$

where V_i is normalized (ranged from 0 to 1) R, G, or B signal coming from the white balancing module, and V_o is normalized final output. The Gamma values (parameter γ) are provided in 205B, use register 0x2c (AD_GAMMA) to select one of them:

- AD_GAMMA 0 : Gamma = 1 (no Gamma)
- AD_GAMMA 1 : Gamma = 1.3
- AD_GAMMA 2 : Gamma = 1.5
- AD_GAMMA 3 : Gamma = 1.7
- AD_GAMMA 4 : Gamma = 1.9
- AD_GAMMA 5 : Gamma = 2.2
- AD_GAMMA 6 : Gamma = 2.5

Brightness

The Brightness offset can be adjusted by Brightness Offset register 0x2B (AD_BRIGHT_OFFSET, Default =0). The default value =0 means the Brightness is not adjusted.

The following examples show how to increase/decrease the Brightness Level:

- Increase Brightness by 10: AD_BRIGHT_OFFSET = 0x0A
- Decrease Brightness by 10: AD_BRIGHT_OFFSET = 0x8A



Hue

The Hue function is used to change the image color temperature. The color temperature is changed by rotating the (U,V) vector:

$$U' = U * \text{COS} + V * \text{SIN}$$
$$V' = U * \text{COS} - V * \text{SIN}$$

The value of COS and SIN is define in the following registers:

0x29 (AD_SIN, Default = 0)

The SIN value. Default = 0x00 is equal to AD_SIN = 0.

0x2A (AD_COS, Default = 0x7F)

The COS value. Default = 0x7F is equal to AD_COS = 1.

Contrast

The Contrast function is control by the following function

$$Y' = Y * \text{CONTRAST}$$

The following registers:

0x28 (AD_CONTRAST, Default = 0x20)

Unsigned 1.5 format(bit5~bit0).

Output Format

The following output data format is provided:

8-bit YCbCr

16-bit YCbCr

16-bit RGB

24-bit RGB

8-bit raw data

The output mode can be VGA or Sub-sampling QVGA and QQVGA. Register 0x52 (AD_OUTSEL) is used to select the various output format and output mode.



The formula for YCbCr format is as follows (note that $16 \leq Y \leq 235$, and $16 \leq C_b, C_r \leq 240$):

The following table lists the user modes and the corresponding signals appeared on the pins.

Format	DOUT[15:8]	DOUT[7:0]	PCLK/VGA	PCLK/QVGA	PCLK/QQVGA
8-bit 4:2:2 YCbCr	0	Y,Cb,Y,Cr ...	24 MHz	6 MHz	1.5M
16-bit 4:2:2 YCbCr	Y, Y, ...	Cb, Cr, ...	12 MHz	3 MHz	0.75M
16-bit RGB (5,6,5)	RG	GB	12 MHz	3 MHz	0.75M
24-bit RGB	G, G, ...	R, B, ...	24MHz	Invalid	Invalid



Control Registers by serial bus

Note : *1 Need PART_CONTROL [7] to change value
*2 Need PART_CONTROL [2] to change value

Address	Name	Default	Description
0x00	PART_CONTROL	0x00	Processing control [0] Mode select 0: Normal mode, 1: Single frame mode [2] Exposure time control, writing a 1 will activate the new value set in AD_EXPOSE_TIME, when read back from it, 0 means either the exposure time change is finished (in video mode) or the entire frame is transmitted (in single frame mode), 1 means either the exposure time change is still in progress (in video mode) or the frame is yet to finish (in single frame mode) [6:3] Frame rate, 0: 30 fps 1: 15 fps 2: 10 fps 3: 6 fps 4: 5 fps 5: 3 fps 6: 2 fps 7: 1 fps [7] Latent change, writing a 1 means the changed latent registers now starts taking effect, when the entire operation is done, the read back value of this bit will change from 1 to 0.



0x01 0x02	TIMING_CONTROL_LOW TIMING_CONTROL_HIGH	0x0219	Timing control [0] Reserved [1] HSYNC polarity, 0: Active low 1: Active high [2] VSYNC polarity 0: Active low 1: Active high. [3] Auto dark correction 0: Disable 1: Enable [4] Reserved [7] Blank polarity 0: Active high 1: Active low [8] Reserved [9] Reserved [10] Capture: when in single frame mode, writing a 1 here will start a frame capture [11] Reserved [12] Reserved [13] Reserved [14] Reserved [15] Reserved
--------------	---	--------	--



0x0C 0x0D	AD_WIDTHL AD_WIDTHH	0x0302 (770)	[9:0] Frame width (*1)
0x0E 0x0F	AD_HEIGHTL AD_HEIGHTH	0x0208 (520)	[15:0] Frame height, should not be less than AD_ROW_BEGIN + 298 (*1)
0x10 0x11	AD_COL_BEGINL AD_COL_BEGINH	0x0064 (100)	[9:0] Beginning of active line in terms of column position (*1) [10] Left-right Mirror image (*1) 0: Disable 1: Enable [11] Up-Down Mirror image (*1) 0: Disable 1: Enable [15:13] Raw Data Digital gain 0: 1 1: 2 2: 4 3: 8 4: 16 5: 32 6: 64
0x14 0x15	AD_ROW_BEGINL AD_ROW_BEGINH	0x000A (10)	[15:0] Beginning of active frame in terms of row position (*1)
0x18 0x19	AD_HSYNC_ENDL AD_HSYNC_ENDH	0x0040 (64)	[9:0] End of horizontal sync in terms of column position (*1)
0x1A 0x1B	AD_VSYNC_ENDL AD_VSYNC_ENDH	0x0003 (3)	[15:0] End of vertical sync in terms of row position (*1)
0x1C 0x1D	AD_EXPOSE_TIMEL AD_EXPOSE_TIMEH	0x0207 (519)	[15:0] Exposure time in terms of number of rows (*2)
0x20 0x21	AD_M1_L AD_M1_H	0x0100	[10:0] Gain coefficient. (G1), unsigned 3.8 format (*1)
0x22 0x23	AD_M2_L AD_M2_H	0x0100	[10:0] Gain coefficient. (R), unsigned 3.8 format (*1)
0x24 0x25	AD_M3_L AD_M3_H	0x0167	[10:0] Gain coefficient. (B), unsigned 3.8 format (*1)
0x26 0x27	AD_M4_L AD_M4_H	0x0100	[10:0] Gain coefficient. (G2), unsigned 3.8 format (*1)
0x28	AD_CONTRAST	0X20	[5:0] Y contrast , unsigned 1.5 format
0x29	AD_HUE_SIN	0X00	[7:0] Hue SIN value (0.7 format) (*1) [7] Sign bit 0: Positive 1: Negative
0x2A	AD_HUE_COS	0X7F	[7:0] Hue COS value (0.7 format) (*1) [7] Sign bit 0: Positive 1: Negative
0X2B	AD_BRIGHT_OFFSET	0X00	[7:0] Brightness offset value [7] Sign bit 0: Positive 1: Negative



			[6:0] Offset value
0x2C	AD_GAMMA	0x01	[2:0] Gamma Control 0 : Gamma = 1 1 : Gamma = 1.3(default) 2 : Gamma = 1.5 3 : Gamma = 1.7 4 : Gamma = 1.9 5 : Gamma = 2.2 6 : Gamma = 2.5
0x2D	AD_SATURATION	0x30	[6:0] Saturation factor, 2.5 Format (U,V) = (U,V)*Saturation
0x2E	AD_DSP_TEST	0xFF	Reserved
0x2F	AD_DSP_CTRL	0x00	Reserved
0x30	AD_SHARP_CTRL	0x09	[3] 1: Sharpening 0: Disable 1: Enable [2:0] : High tone weight 0: 0.5 1: 1 (default) 2: 2 3: 3 4: 4 5: 5 6: 6 7: 7
0x31	AD_SHARP_HIGH	0x0a	Reserved
0x32	AD_SHARP_LOW	0x05	Reserved
0x33	AD_AWB_CTRL	0x03	[0] Auto White Balance (AWB) 0: Disable AWB 1: Enable AWB [1] Reserved [2] Reserved
0x34	AD_AWB_OVERFLOW	0xff	Reserved
0x35	AD_AWB_BRIGHT	0x00	Reserved
0x36	AD_DG_GAIN	0x18	[7:0] Color DSP Digital Gain, (4.4 format)
0x37	AD_WB_RED	0x80	[7:0] AWB R Gain, (1.7 format) (*1)
0x38	AD_WB_GREEN	0x80	[7:0] AWB G Gain, (1.7 format) (*1)
0x39	AD_WB_BLUE	0x80	[7:0] AWB B Gain, (1.7 format) (*1)
0x3A	AD_AE_CTRL	0x07	[0] Auto Exposure 0: Disable AE 1: Enable AE [1] Digital Gain 0: Disable 1: Enable [2] Anti-Flicker 0: Disable 1: Enable [3] Fix frame height 0: Disable 1: Enable [4] Reserved



0x3B	AD_AEHIGH	0x65 (101)	[7:0] AE High Limit
0x3C	AD_AELOW	0x55 (85)	[7:0] AE Low Limit
0x3D 0x3E	AD_BRIGHTLIMITL AD_BRIGHTLIMITH	0x0fff (4096)	[15:0] Bright pixel number limit
0x3F 0x40	AD_MAXFHL AD_MAXFHH	0x1450 (5200)	[15:0] Max. frame height, in term of row
0x41 0x42	AD_MINFHL AD_MINFHH	0x0208 (520)	[15:0] Min. frame height, in term of row
0x43	AD_AESTEP	0x00	[6:0] AE adjust exposure time step
0x44	AD_AFSTEP	0x82 (130)	[7:0] Anti -Flicker Exposure time adjust step
0x45	AD_YBRIGHT	0xc0 (192)	Reserved
0x47	AD_RGAIN_LIMIT	0xff	[7:0] Reserved
0x48	AD_GGAIN_LIMIT	0xff	[7:0] Reserved
0x49	AD_BGAIN_LIMIT	0xff	[7:0] Reserved
0x4A	AD_AE_PERIOD	0x05	[5:0] Reserved
0x4C	AD_AWB_PERIOD	0x00	[5:0] Reserved
0x51	AD_OUTMODE	0x00	[1:0] Output Mode Select (*1) 0 : VGA 1 : QVGA 2 : QQVGA [2] Adjust pclk under QVGA and QQVGA [3] YCbCr clamp *1 0: Clamp 16-235 1: Full range 0-255 [7:4] Sub-sample counter reset value
0x52	AD_OUTSEL	0x6d	[7] Auto Blank Signal Enable 0: Auto Blank 1: Manual Blank [6] change CbCr sequence [5] change Y sequence [4:0] Normal Output format, 0-7: 8-bit RAW data (After Dark Compensation) 8: control signals, 9bit 9: row address, 9bit 10: column address, 10bit 11: 9-bit sensor RAW data 13: 8-bit 4-2-2 YcrCb (default) 15: 16-bit 4-2-2 YCrYCb 16: 24-bit RGB GRGB 17: 16-bit RGB (5,6,5) 31: 8-bit YCbCr debug mode, no gamma, saturation, contrast, brightness, hue
0x53	AD_RAMPSEL	0x00	[7] Reserved
0x54 0x55	AD_DSRSTL AD_DSRSTH	0x00	[8:0] Reserved
0x56	AD_DSDATAL	0x01f9	[8:0] Reserved



0x57	AD_DSDATAH	(505)	
0x58	AD_DSLOWL	0x00ff	[8:0] Reserved
0x59	AD_DSLOWH	(255)	
0x5A	AD_DSHIGHL	0x011d	[8:0] Reserved d
0x5B	AD_DSHIGHH	(285)	
0x68	AD_DEADR0L	0x01ff	[8:0] Dead Pixel #0 Row Address
0x69	AD_DEADR0H		
0x6A	AD_DEADC0L	0x03ff	[9:0] Dead Pixel #0 Column Address
0x6B	AD_DEADC0H		
0x6C	AD_DEADR1L	0x01ff	[8:0] Dead Pixel #1 Row Address
0x6D	AD_DEADR1H		
0x6E	AD_DEADC1L	0x03ff	[9:0] Dead Pixel #1 Column Address
0x6F	AD_DEADC1H		
0x70	AD_DEADR2L	0x01ff	[8:0] Dead Pixel #2 Row Address
0x71	AD_DEADR2H		
0x72	AD_DEADC2L	0x03ff	[9:0] Dead Pixel #2 Column Address
0x73	AD_DEADC2H		
0x74	AD_DEADR3L	0x01ff	[8:0] Dead Pixel #3 Row Address
0x75	AD_DEADR3H		
0x76	AD_DEADC3L	0x03ff	[9:0] Dead Pixel #3 Column Address
0x77	AD_DEADC3H		
0x78	AD_DEADR4L	0x01ff	[8:0] Dead Pixel #4 Row Address
0x79	AD_DEADR4H		
0x7A	AD_DEADC4L	0x03ff	[9:0] Dead Pixel #4 Column Address
0x7B	AD_DEADC4H		
0x7C	AD_DEADR5L	0x01ff	[8:0] Dead Pixel #5 Row Address
0x7D	AD_DEADR5H		
0x7E	AD_DEADC5L	0x03ff	[9:0] Dead Pixel #5 Column Address
0x7F	AD_DEADC5H		
0x82	AD_IDL	0xa050	[3:0] Sub ID
0x83	AD_IDH		[15:4] Device ID, default 0xa050(205B), can be configured using serial bus
0x88	AD_BWIDTH_BEGINL	0x0074	[9:0] Blank begin in terms of columns
0x89	AD_BWIDTH_BEGINH	(116)	
0x8A	AD_BWIDTH_ENDL	0x02f3	[9:0] Blank end in terms of columns
0x8B	AD_BWIDTH_ENDH	(755)	
0x8C	AD_BHEIGHT_BEGINL	0x0011	[15:0] Blank begin in terms of rows
0x8D	AD_BHEIGHT_BEGINH	(17)	
0x8E	AD_BHEIGHT_ENDL	0x01f0	[15:0] Blank end in terms of rows
0x8F	AD_BHEIGHT_ENDH	(496)	
0x90	AD_DARK_DATA	0	[7:0] When auto dark correction is disabled, serve as the subtrahend for dark correction
0x91	AD_SLOPEREG	0x1a	Reserved
0x92	AD_TXRSTSEL	0x52	Reserved
0x93	AD_SUBPH_PULSE	0x10	Reserved
0x94	AD_BITCONTROL	0x02	Reserved
0x95	AD_SLOPE_END_TIMEL	0x02a9	Reserved



0x96	AD_SLOPE_END_TIMEH	(681)	
0x97	AD_WT_BEGINL	0x00	Reserved
0x98	AD_WT_BEGINH		
0x99	AD_WT_ENDL	0x03fc	Reserved
0x9A	AD_WT_ENDH	(1020)	
0x9B	AD_SUB_EN_TIMEL	0x02f0	Reserved
0x9C	AD_SUB_EN_TIMEH	(752)	
0xA1	AD_WIDTHL_C	0x0302	[9:0] Current frame width, read only
0xA2	AD_WIDTHH_C	(770)	
0xA3	AD_HEIGHTL_C	0x0208	[15:0] Current frame height, read only
0xA4	AD_HEIGHTH_C	(520)	
0xA5	AD_COL_BEGINL_C	0x0064	[9:0] Current column beginning position, read only
0xA6	AD_COL_BEGINH_C	(100)	
0xA7	AD_ROW_BEGINL_C	0x000a	[9:0] Current row beginning position, read only
0xA8	AD_ROW_BEGINH_C	(10)	
0xA9	AD_HSYNC_ENDL_C	0x0040	[9:0] Current HSync end position, read only
0xAA	AD_HSYNC_ENDH_C	(64)	
0xAB	AD_VSYNC_ENDL_C	0x0003	[15:0] Current VSync end position, read only
0xAC	AD_VSYNC_ENDH_C	(3)	
0xAD	AD_PART_CONTROL_C	0x00	[7:0] Current part control setting, read only
		(0)	
0xAE	AD_WT_BEGINL_C	Read	Reserved
0xAF	AD_WT_BEGINH_C	Only	
0xB0	AD_WT_ENDL_C	0x03fc	Reserved
0xB1	AD_WT_ENDH_C	(1020)	
0xB2	AD_YAverage	Read	Reserved
		Only	
0xB3	AD_NTBPPL	Read	Reserved
0xB4	AD_NTBPPI	Only	
0xB5	AD_AWBR	Read	Reserved
		Only	
0xB6	AD_AWBG	Read	Reserved
		Only	
0xB7	AD_AWBB	Read	Reserved
		Only	
0xB8	AD_AWBpixelL	Read	Reserved
0xB9	AD_AWBpixelH	Only	

**Electrical Characteristics**DC Characteristics

Symbol	Parameter	Rating			Unit
		Minimum	Typical	Maximum	
V _{CCA}	Absolute Power Supply	-0.3		3.8	V
V _{INA}	Absolute Input Voltage	-0.3		V _{CC} + 0.3	V
V _{OUTA}	Absolute Output Voltage	-0.3		V _{CC} + 0.3	V
T _{STG}	Storage Temperature	0	25	65	°C
V _{CC}	Operating Power Supply	3.15	3.3	3.45	V
V _{IN}	Operating Input Voltage	0		V _{CC}	V
T _{OPR}	Operating Temperature	0	25	55	°C
I _{DD}	Operating Current @ V _{CC} =2.8 V, 25 °C @6MHz		11		mA
I _{IL}	Input Low Current	-1		1	μA
I _{IH}	Input High Current	-1		1	μA
I _{OZ}	Tri-state Leakage Current	-10		10	μA
C _{IN}	Input Capacitance		3		pF
C _{OUT}	Output Capacitance		3		pF
C _{BID}	Bi-directional Buffer Capacitance		3		pF
V _{IL}	Input Low			0.3 * V _{CC}	V



	Voltage				
V _{ILS}	Schmitt Input Low Voltage		1.1		V
V _{IH}	Input High Voltage	0.7 * V _{CC}			V
V _{IHS}	Schmitt Input High Voltage		1.8		V
V _{OL}	Output Low Voltage			0.4	V
V _{OH}	Output High Voltage	2.4			V
R _L	Input Pull-up/down Resistance		50		KΩ



Timing

Reset/Pixel Timing

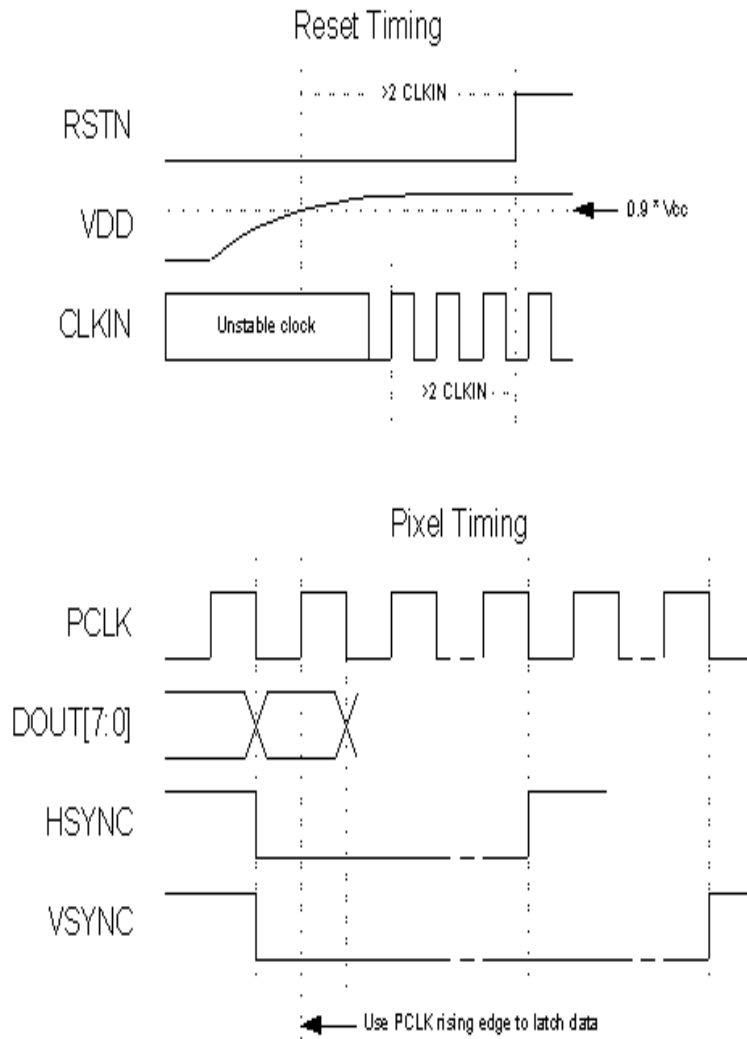



8 bit 4-2-2 YcrCb and 24bit GBR VGA mode

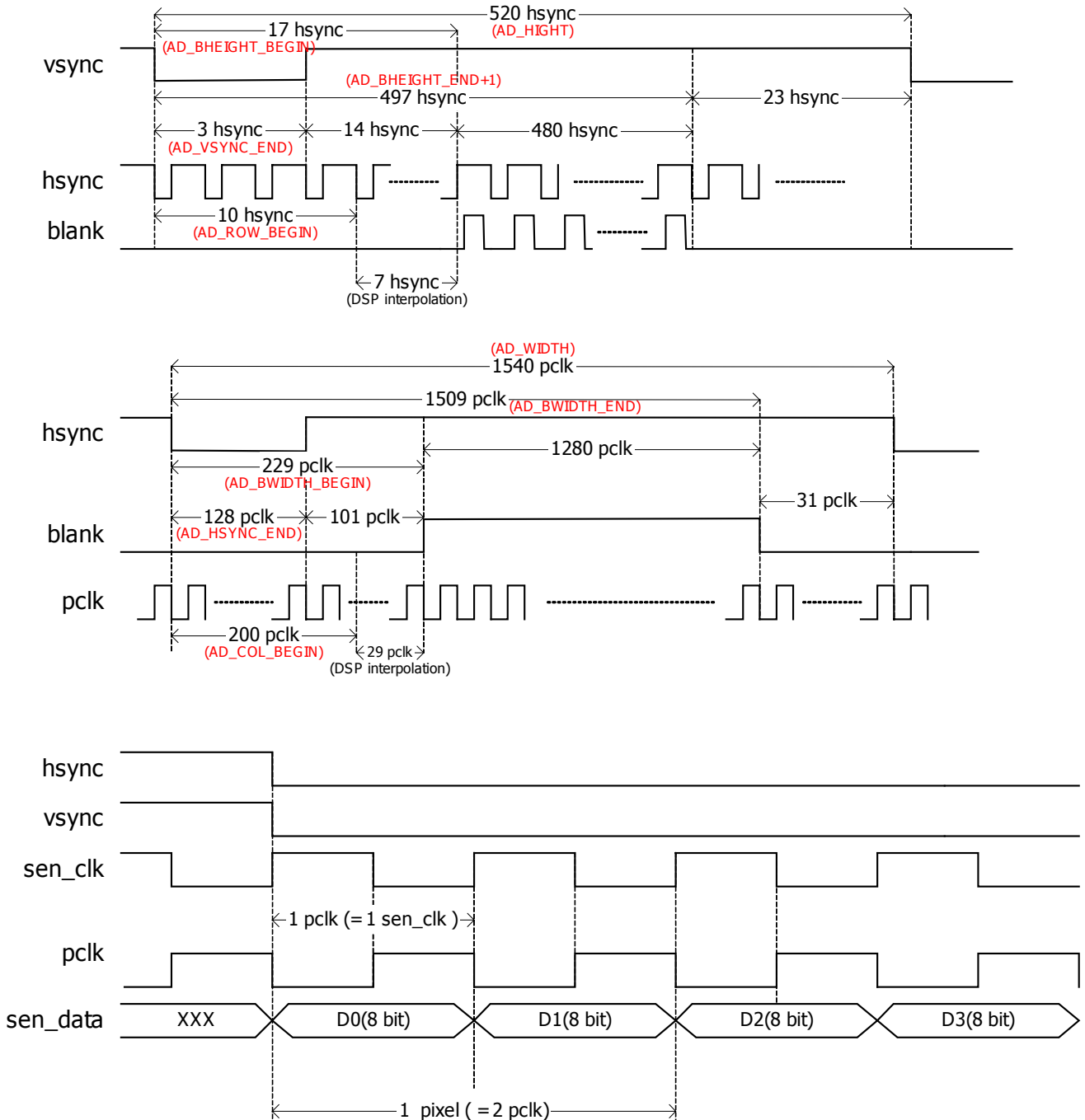



8 bit 4-2-2 YcrCb QVGA mode

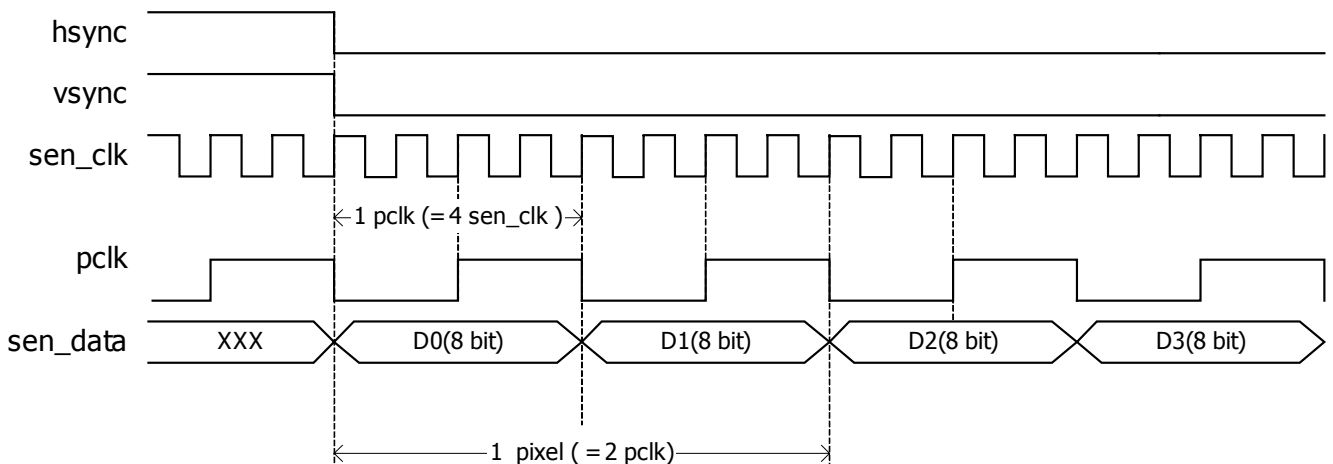
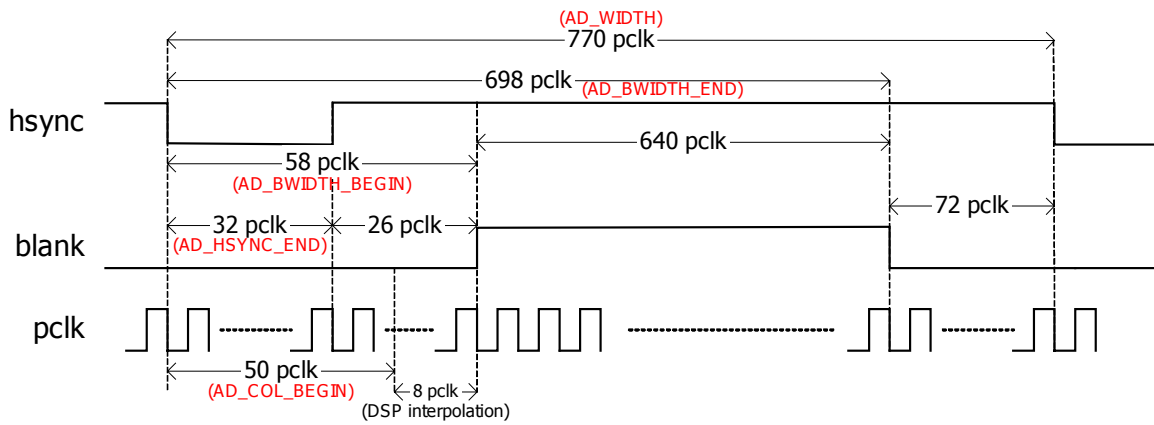
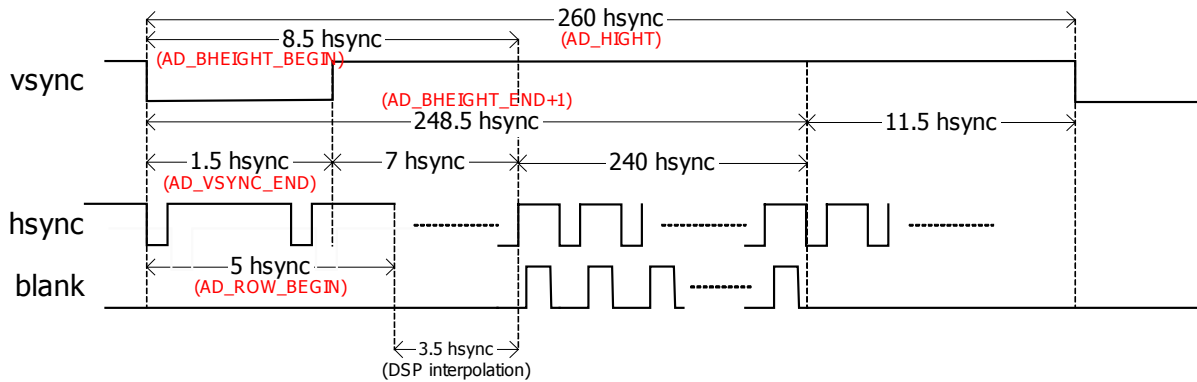



8 bit 4-2-2 YcrCb QQVGA mode

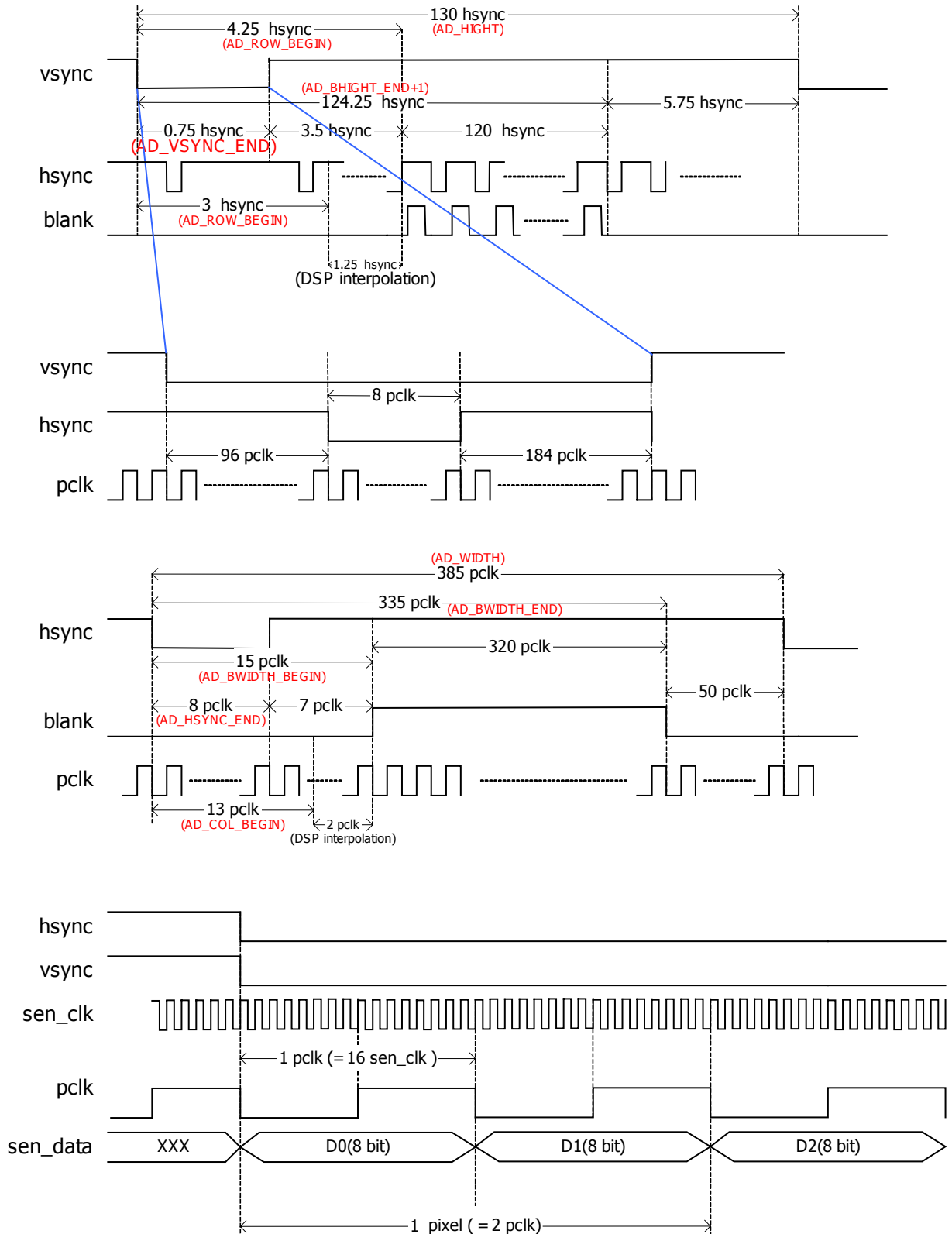



16 bit RGB VGA mode

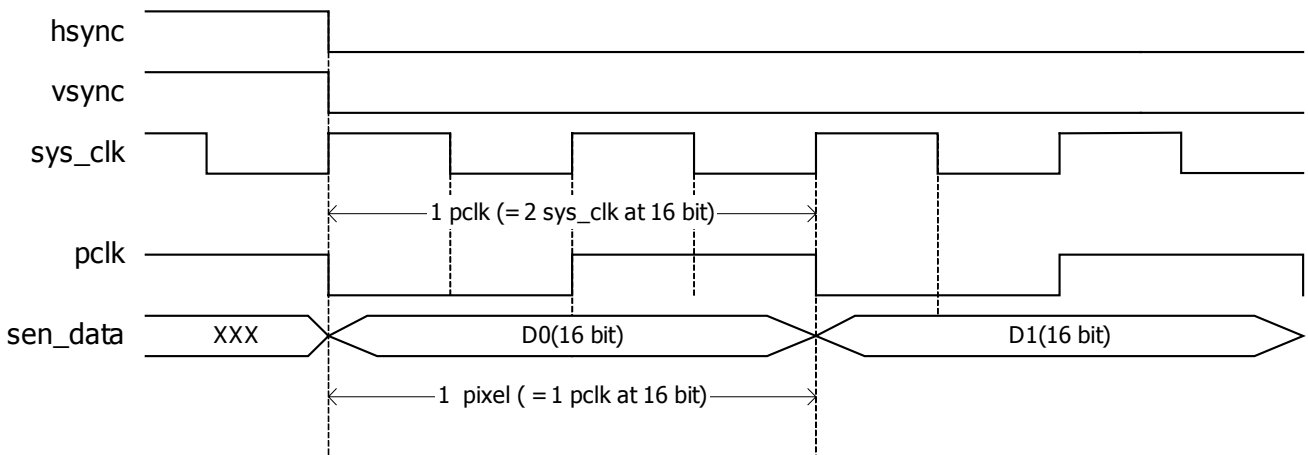
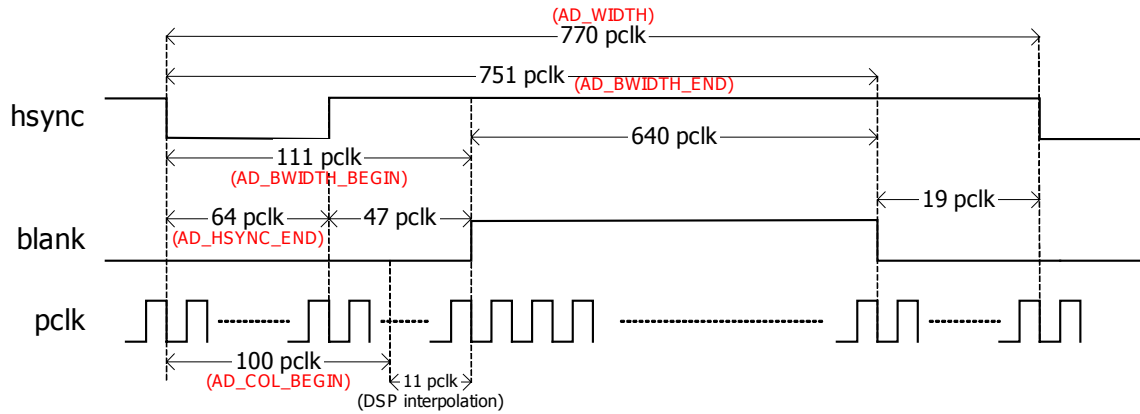
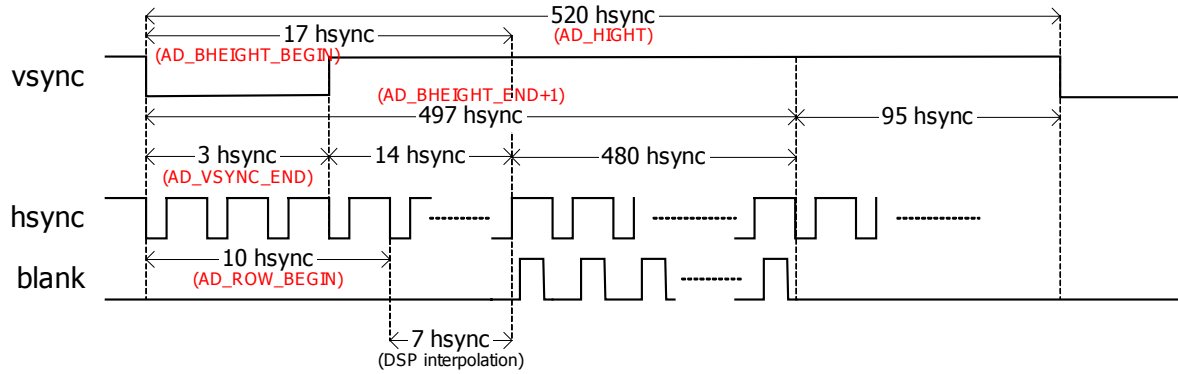



16 bit RGB QVGA mode

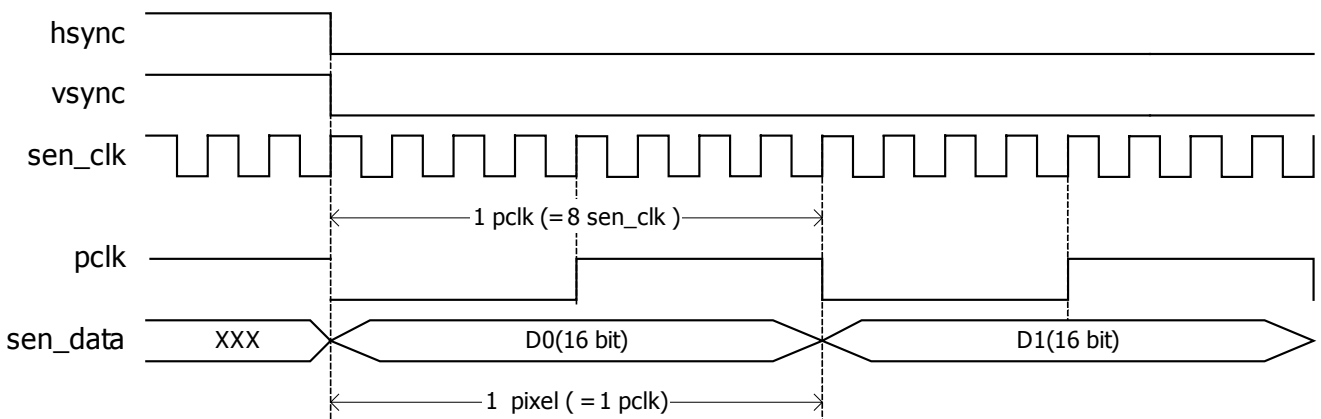
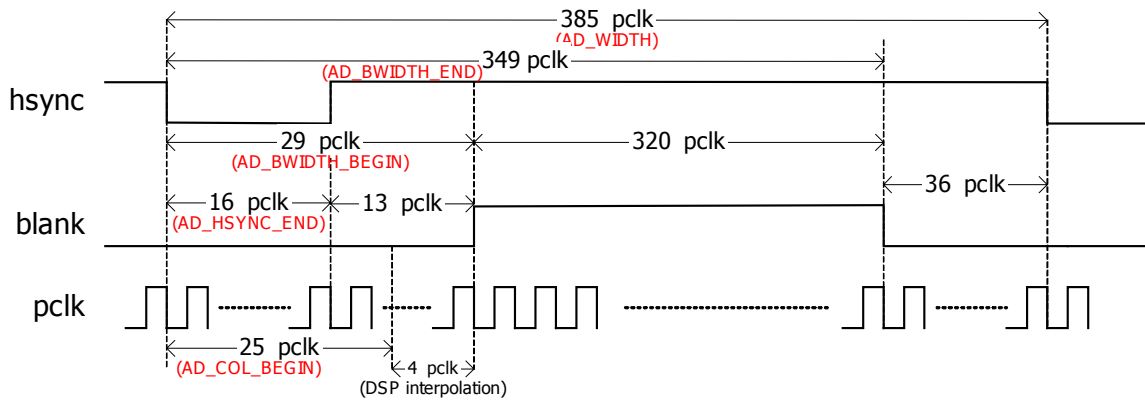
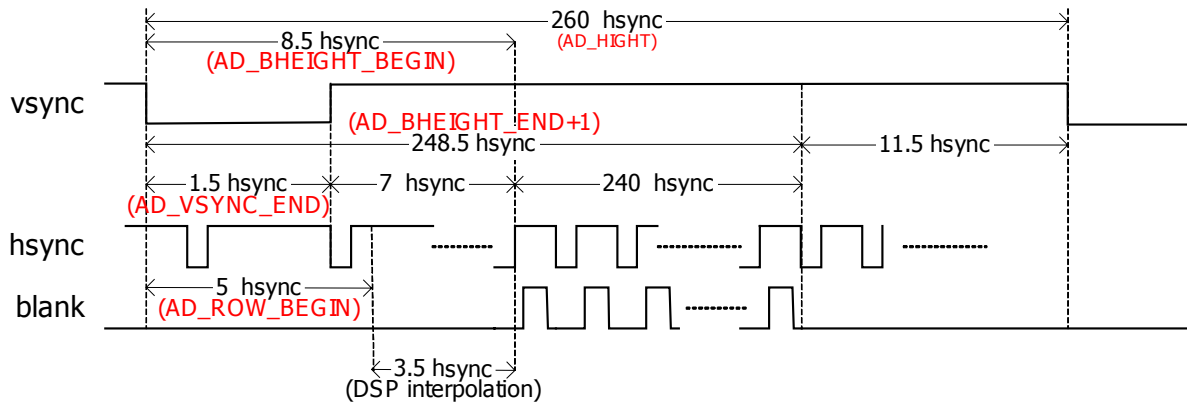



16 bit RGB QQVGA mode

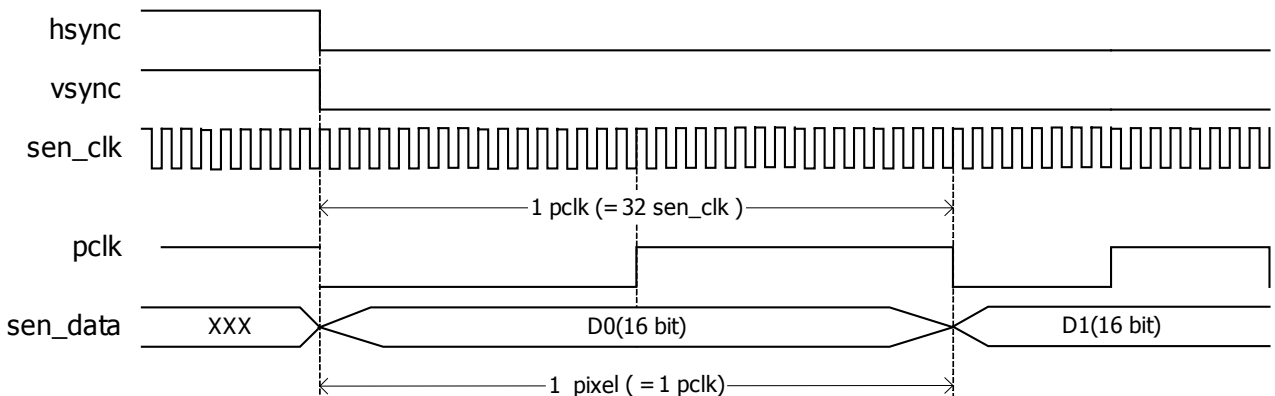
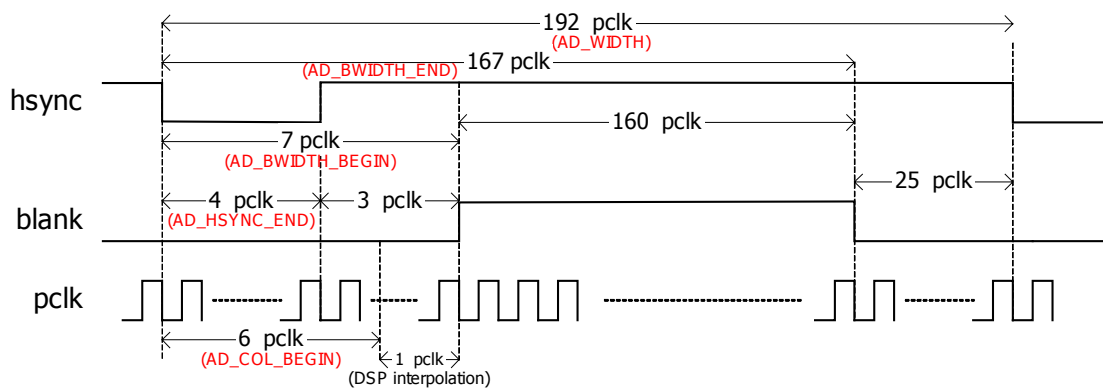
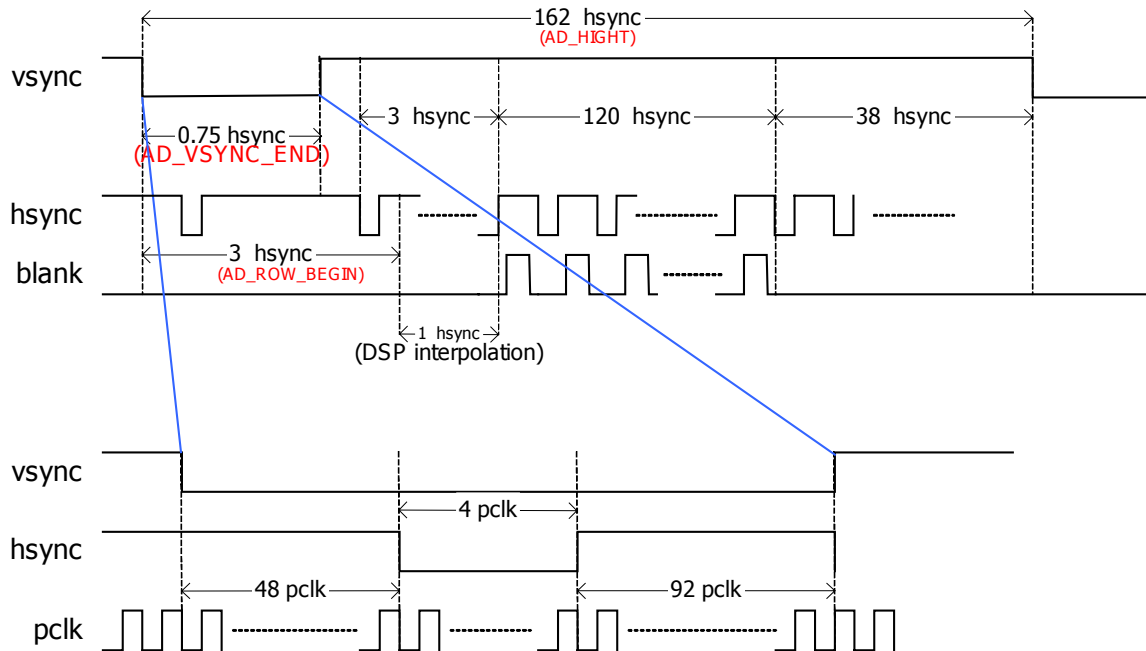



VGA Data format

8-bit 4-2-2 YCrYCb

0x52 bit 6=0 bit5=0

Data out [7:0]

Cr1	Y1	Cb2	Y2	Cr3	Y3	Cb4	Y4	Cr639	Y639	Cb640	Y640
-----	----	-----	----	-----	----	-----	----	-----	-----	-----	-------	------	-------	------

0x52 bit 6=0 bit5=1

Data out [7:0]

Y1	Cb1	Y2	Cr2	Y3	Cb3	Y4	Cr4	Y639	Cb639	Y640	Cr640
----	-----	----	-----	----	-----	----	-----	-----	-----	-----	------	-------	------	-------

0x52 bit 6=1 bit5=1

Data out [7:0]

Cb1	Y1	Cr2	Y2	Cb3	Y3	Cr4	Y4	Cb639	Y639	Cr640	Y640
-----	----	-----	----	-----	----	-----	----	-----	-----	-----	-------	------	-------	------

0x52 bit 6=1 bit5=1

Data out [7:0]

Y1	Cr1	Y2	Cb2	Y3	Cr3	Y4	Cb4	Y639	Cr639	Y640	Cb640
----	-----	----	-----	----	-----	----	-----	-----	-----	-----	------	-------	------	-------



16-bit 4-2-2 YCrYCb

0x52 bit 6=0 bit 5=0

Data out [7:0]

Y1	Y2	Y3	Y4	Y5	Y6	Y7	Y8	Y637	Y638	Y639	Y640
----	----	----	----	----	----	----	----	-----	-----	-----	------	------	------	------

Data out [15:8]

Cb1	Cr2	Cb3	Cr4	Cb5	Cr6	Cb7	Cr8				Cb637	Cr638	Cb639	Cr640
-----	-----	-----	-----	-----	-----	-----	-----	--	--	--	-------	-------	-------	-------

0x52 bit 6=0 bit 5=1

Data out [7:0]

Y1	Y2	Y3	Y4	Y5	Y6	Y7	Y8	Y637	Y638	Y639	Y640
----	----	----	----	----	----	----	----	-----	-----	-----	------	------	------	------

Data out [15:8]

Cb1	Cr2	Cb3	Cr4	Cb5	Cr6	Cb7	Cr8	Cb637	Cr638	Cb639	Cr640
-----	-----	-----	-----	-----	-----	-----	-----	-----	-----	----	-------	-------	-------	-------

0x52 bit 6=1 bit 5=0

Data out [7:0]

Y1	Y2	Y3	Y4	Y5	Y6	Y7	Y8	Y637	Y638	Y639	Y640
----	----	----	----	----	----	----	----	-----	-----	-----	------	------	------	------

Data out [15:8]

Cr1	Cb2	Cr3	Cb4	Cr5	Cb6	Cr7	Cb8	Cr637	Cb638	Cr639	Cb640
-----	-----	-----	-----	-----	-----	-----	-----	-----	-----	-----	-------	-------	-------	-------

0x52 bit 6=1 bit 5=1

Data out [7:0]

Y1	Y2	Y3	Y4	Y5	Y6	Y7	Y8	Y637	Y638	Y639	Y640
----	----	----	----	----	----	----	----	-----	-----	-----	------	------	------	------

Data out [15:8]

Cr1	Cb2	Cr3	Cb4	Cr5	Cb6	Cr7	Cb8	Cr637	Cb638	Cr639	Cb640
-----	-----	-----	-----	-----	-----	-----	-----	-----	-----	-----	-------	-------	-------	-------



24-bit RGB

0x52 bit 6=0 bit 5=0

Data out [7:0]

G1	G1	G2	G2	G3	G3	G4	G4	G639	G639	G640	G640
----	----	----	----	----	----	----	----	-----	-----	-----	------	------	------	------

Data out [15:8]

B1	R1	B2	R2	B3	R3	B4	R4	B639	R639	B640	R640
----	----	----	----	----	----	----	----	-----	-----	-----	------	------	------	------

0x52 bit 6=0 bit 5=1

Data out [7:0]

G1	G1	G2	G2	G3	G3	G4	G4	G639	G639	G640	G640
----	----	----	----	----	----	----	----	-----	-----	-----	------	------	------	------

Data out [15:8]

R1	B1	R2	B2	R3	B3	R4	B4	R639	B639	R640	B640
----	----	----	----	----	----	----	----	-----	-----	-----	------	------	------	------

0x52 bit 6=1 bit 5=0

Data out [7:0]

G1	G1	G2	G2	G3	G3	G4	G4	G639	G639	G640	G640
----	----	----	----	----	----	----	----	-----	-----	-----	------	------	------	------

Data out [15:8]

B1	R1	B2	R2	B3	R3	B4	R4	B639	R639	B640	R640
----	----	----	----	----	----	----	----	-----	-----	-----	------	------	------	------

0x52 bit 6=1 bit 5=1

Data out [7:0]

G1	G1	G2	G2	G3	G3	G4	G4	G639	G639	G640	G640
----	----	----	----	----	----	----	----	-----	-----	-----	------	------	------	------

Data out [15:8]

R1	B1	R2	B2	R3	B3	R4	B4	R639	B639	R640	B640
----	----	----	----	----	----	----	----	-----	-----	-----	------	------	------	------



16-bit RGB (5,6,5)

Data out [15:0]

D[15:11] → R, D[10:5] → G, D[4:0] → B

5bit	6bit	5bit	5bit	6bit	5bit	5bit	6bit	5bit	5bit	6bit	5bit
------	------	------	------	------	------	------	------	------	-----	-----	-----	------	------	------

R1	G1	B1	R2	G2	B2	R3	G3	B3	R640	G640	B640
----	----	----	----	----	----	----	----	----	-----	-----	-----	------	------	------





QVGA Data format

8-bit 4-2-2 YCrYCb

0x52 bit 6=0 bit5=0

Data out [7:0]

Cr1	Y1	Cb2	Y2	Cr3	Y3	Cb4	Y4	Cr319	Y319	Cb320	Y320
-----	----	-----	----	-----	----	-----	----	-----	-----	-----	-------	------	-------	------

0x52 bit 6=0 bit5=1

Data out [7:0]

Cb1	Y1	Cr2	Y2	Cb3	Y3	Cr3	Y4	Cb319	Y319	Cr320	Y320
-----	----	-----	----	-----	----	-----	----	-----	-----	-----	-------	------	-------	------

0x52 bit 6=1 bit5=0

Data out [7:0]

Y1	Cr1	Y2	Cb2	Y3	Cr3	Y4	Cb4	Y319	Cr319	Y320	Cb320
----	-----	----	-----	----	-----	----	-----	-----	-----	-----	------	-------	------	-------

0x52 bit 6=1 bit5=1

Data out [7:0]

Y1	Cb1	Y2	Cr2	Y3	Cb3	Y4	Cr4	Y319	Cb319	Y320	Cr320
----	-----	----	-----	----	-----	----	-----	-----	-----	-----	------	-------	------	-------



16-bit 4-2-2 YCrYCb

0x52 bit 6=0 bit 5=0

Data out [7:0]

Cr1	Cb2	Cr3	Cb4	Cr5	Cb6	Cr7	Cb8	Cr317	Cb318	Cr319	Cb320
-----	-----	-----	-----	-----	-----	-----	-----	-----	-----	-----	-------	-------	-------	-------

Data out [15:8]

Y1	Y2	Y3	Y4	Y5	Y6	Y7	Y8				Y317	Y318	Y319	Y320
----	----	----	----	----	----	----	----	--	--	--	------	------	------	------

0x52 bit 6=0 bit 5=1

Data out [7:0]

Cb1	Cr2	Cb3	Cr4	Cb5	Cr6	Cb7	Cr8	Cb317	Cr318	Cb319	Cr320
-----	-----	-----	-----	-----	-----	-----	-----	-----	-----	-----	-------	-------	-------	-------

Data out [15:8]

Y1	Y2	Y3	Y4	Y5	Y6	Y7	Y8	Y317	Y318	Y319	Y320
----	----	----	----	----	----	----	----	-----	-----	-----	------	------	------	------

0x52 bit 6=1 bit 5=0

Data out [7:0]

Y1	Y2	Y3	Y4	Y5	Y6	Y7	Y8	Y317	Y318	Y319	Y320
----	----	----	----	----	----	----	----	-----	-----	-----	------	------	------	------

Data out [15:8]

Cr1	Cb2	Cr3	Cb4	Cr5	Cb6	Cr7	Cb8	Cr317	Cb318	Cr319	Cb320
-----	-----	-----	-----	-----	-----	-----	-----	-----	-----	-----	-------	-------	-------	-------

0x52 bit 6=1 bit 5=1

Data out [7:0]

Y1	Y2	Y3	Y4	Y5	Y6	Y7	Y8	Y317	Y318	Y319	Y320
----	----	----	----	----	----	----	----	-----	-----	-----	------	------	------	------

Data out [15:8]

Cb1	Cr2	Cb3	Cr4	Cb5	Cr6	Cb7	Cr8	Cb317	Cr318	Cb319	Cr320
-----	-----	-----	-----	-----	-----	-----	-----	-----	-----	-----	-------	-------	-------	-------



16-bit RGB (5,6,5)

Data out [15:0]

D[15:11] → R, D[10:5] → G, D[4:0] → B

5bit	6bit	5bit	5bit	6bit	5bit	5bit	6bit	5bit	5bit	6bit	5bit
------	------	------	------	------	------	------	------	------	-----	-----	-----	------	------	------

R1	G1	B1	R2	G2	B2	R3	G3	B3	R320	G320	B320
----	----	----	----	----	----	----	----	----	-----	-----	-----	------	------	------





QQVGA Data format

8-bit 4-2-2 YrYCb

0x52 bit 6=0 bit5=0

Data out [7:0]

Cr1	Y1	Cb2	Y2	Cr3	Y3	Cb4	Y4	Cr159	Y159	Cb160	Y160
-----	----	-----	----	-----	----	-----	----	-----	-----	-----	-------	------	-------	------

0x52 bit 6=0 bit5=1

Data out [7:0]

Cb1	Y1	Cr2	Y2	Cb3	Y3	Cr3	Y4	Cb159	Y159	Cr160	Y160
-----	----	-----	----	-----	----	-----	----	-----	-----	-----	-------	------	-------	------

0x52 bit 6=1 bit5=0

Data out [7:0]

Y1	Cr1	Y2	Cb2	Y3	Cr3	Y4	Cb4	Y159	Cr159	Y160	Cb160
----	-----	----	-----	----	-----	----	-----	-----	-----	-----	------	-------	------	-------

0x52 bit 6=1 bit5=1

Data out [7:0]

Y1	Cb1	Y2	Cr2	Y3	Cb3	Y4	Cr4	Y159	Cb159	Y160	Cr160
----	-----	----	-----	----	-----	----	-----	-----	-----	-----	------	-------	------	-------



16-bit 4-2-2 YCrYCb

0x52 bit 6=0 bit 5=0

Data out [7:0]

Cr1	Cb2	Cr3	Cb4	Cr5	Cb6	Cr7	Cb8	Cr157	Cb158	Cr159	Cb160
-----	-----	-----	-----	-----	-----	-----	-----	-----	-----	-----	-------	-------	-------	-------

Data out [15:8]

Y1	Y2	Y3	Y4	Y5	Y6	Y7	Y8				Y157	Y158	Y159	Y160
----	----	----	----	----	----	----	----	--	--	--	------	------	------	------

0x52 bit 6=0 bit 5=1

Data out [7:0]

Cb1	Cr2	Cb3	Cr4	Cb5	Cr6	Cb7	Cr8	Cb157	Cr158	Cb159	Cr160
-----	-----	-----	-----	-----	-----	-----	-----	-----	-----	-----	-------	-------	-------	-------

Data out [15:8]

Y1	Y2	Y3	Y4	Y5	Y6	Y7	Y8	Y157	Y158	Y159	Y160
----	----	----	----	----	----	----	----	-----	-----	-----	------	------	------	------

0x52 bit 6=1 bit 5=0

Data out [7:0]

Y1	Y2	Y3	Y4	Y5	Y6	Y7	Y8	Y157	Y158	Y159	Y160
----	----	----	----	----	----	----	----	-----	-----	-----	------	------	------	------

Data out [15:8]

Cr1	Cb2	Cr3	Cb4	Cr5	Cb6	Cr7	Cb8	Cr157	Cb158	Cr159	Cb160
-----	-----	-----	-----	-----	-----	-----	-----	-----	-----	-----	-------	-------	-------	-------

0x52 bit 6=1 bit 5=1

Data out [7:0]

Y1	Y2	Y3	Y4	Y5	Y6	Y7	Y8	Y157	Y158	Y159	Y160
----	----	----	----	----	----	----	----	-----	-----	-----	------	------	------	------

Data out [15:8]

Cb1	Cr2	Cb3	Cr4	Cb5	Cr6	Cb7	Cr8	Cb157	Cr158	Cb159	Cr160
-----	-----	-----	-----	-----	-----	-----	-----	-----	-----	-----	-------	-------	-------	-------



16-bit RGB (5,6,5)

Data out [15:0]

D[15:11] → R, D[10:5] → G, D[4:0] → B

5bit	6bit	5bit	5bit	6bit	5bit	5bit	6bit	5bit	5bit	6bit	5bit
------	------	------	------	------	------	------	------	------	-----	-----	-----	------	------	------

R1	G1	B1	R2	G2	B2	R3	G3	B3	R160	G160	B160
----	----	----	----	----	----	----	----	----	-----	-----	-----	------	------	------



Pixel Clock Duty Cycle

In different frame rate mode (controlled by PART_CONTROL[6:3]), the duty cycle (high time / clock period) of the PCLK signal is described in the following table:

Frame Rate	Duty Cycle
30	50.0%
15	50.0%
10	66.6%
6	60.0%
5	50.0%
3	50.0%
2	53.3%
1	50.0%



Mechanical Information

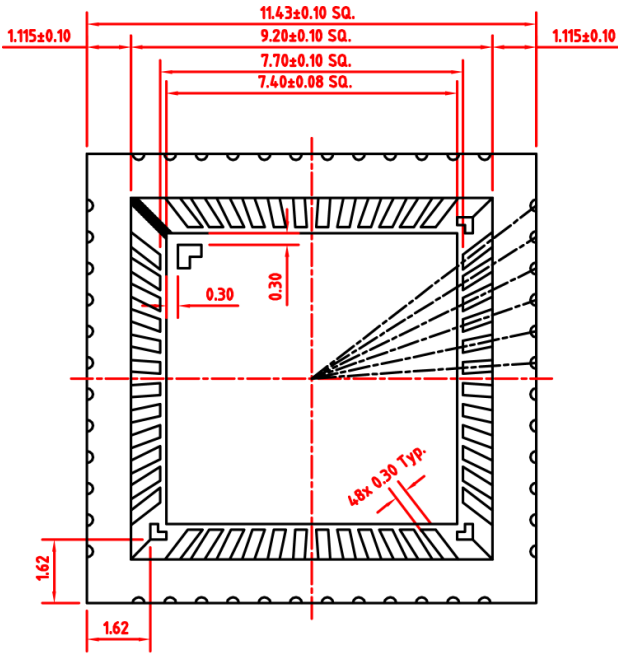

Unit Top View

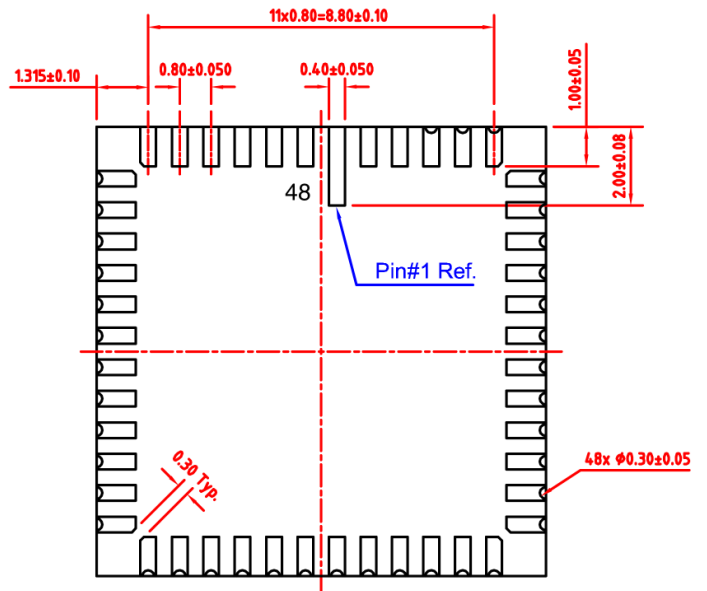

Unit Bottom View

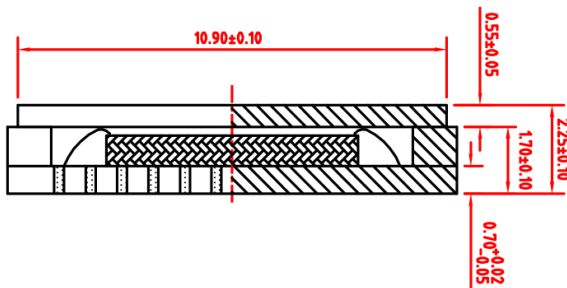

Unit Side View

Figure 3. Shrunk PLCC48 Packaging



Ordering Information

Part number for different package:

<i>Description</i>	<i>Part Number</i>
Shrunk Plastic LCC 48 packaged, VGA resolution sensor with YUV output	ICM-205Bsa