Features

- IC Distinguishes the Signal Strength of Several Transmitters via RSSI (Received Signal Strength Indicator) Output
- Minimal External Circuitry Requirements, No RF Components on the PC Board Except Matching to the Receiver Antenna
- High Sensitivity, Especially at Low Data Rates
- Sensitivity Reduction Possible Even While Receiving
- Fully Integrated VCO
- Low Power Consumption Due to Configurable Self-polling with a Programmable Time Frame Check
- Supply Voltage 4.5 V to 5.5 V
- Operating Temperature Range -40°C to 105°C
- Single-ended RF Input for Easy Adaptation to $\lambda/4$ Antenna or Printed Antenna on PCB
- Low-cost Solution Due to High Integration Level
- ESD Protection According to MIL-STD. 883 (4 KV HBM)
- High Image Frequency Suppression Due to 1 MHz IF in Conjunction with a SAW Front-end Filter (Up to 40 dB Achievable with Newer SAWs)
- Communication to Microcontroller Possible via a Single, Bi-directional Data Line
- Power Management (Polling) is also Possible by Means of a Separate Pin via the Microcontroller

Description

The U3742BM is a multi-chip PLL receiver device supplied in an SO20 package. It has been especially developed for the demands of RF low-cost data transmission systems with data rates from 1 kBaud to 10 kBaud (1 kBaud to 3.2 kBaud for FSK) in Manchester or Bi-phase code. The receiver is well suited to operate with Atmel's PLL RF transmitter IC U2741B. Its main applications in the area of wireless control are telemetering, security technology, tire-pressure monitoring and keyless-entry systems. It can be used in the frequency receiving range of $f_0 = 300$ MHz to 450 MHz for ASK or FSK data transmission. All the statements made in this data sheet refer both to 433.92 MHz and 315 MHz applications.



UHF ASK/FSK Receiver

U3742BM

Rev. 4735A-RKE-11/03



Figure 1. System Block Diagram

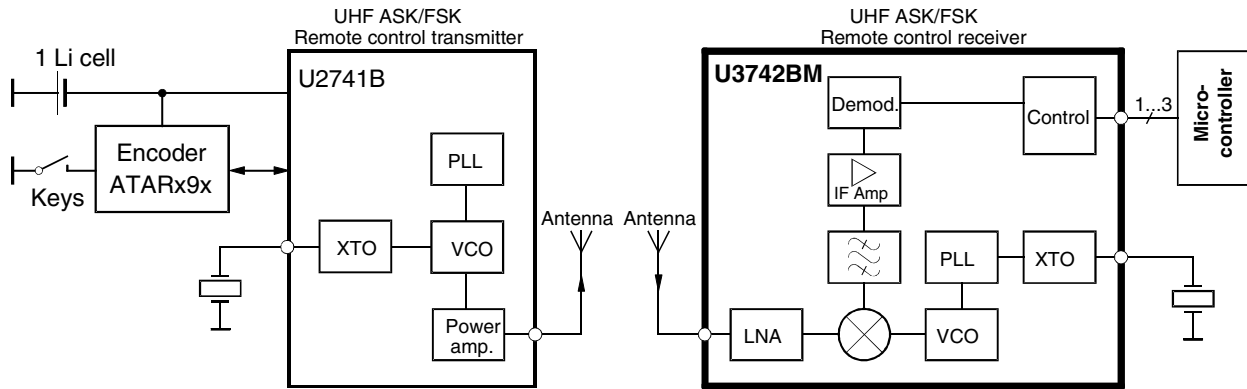
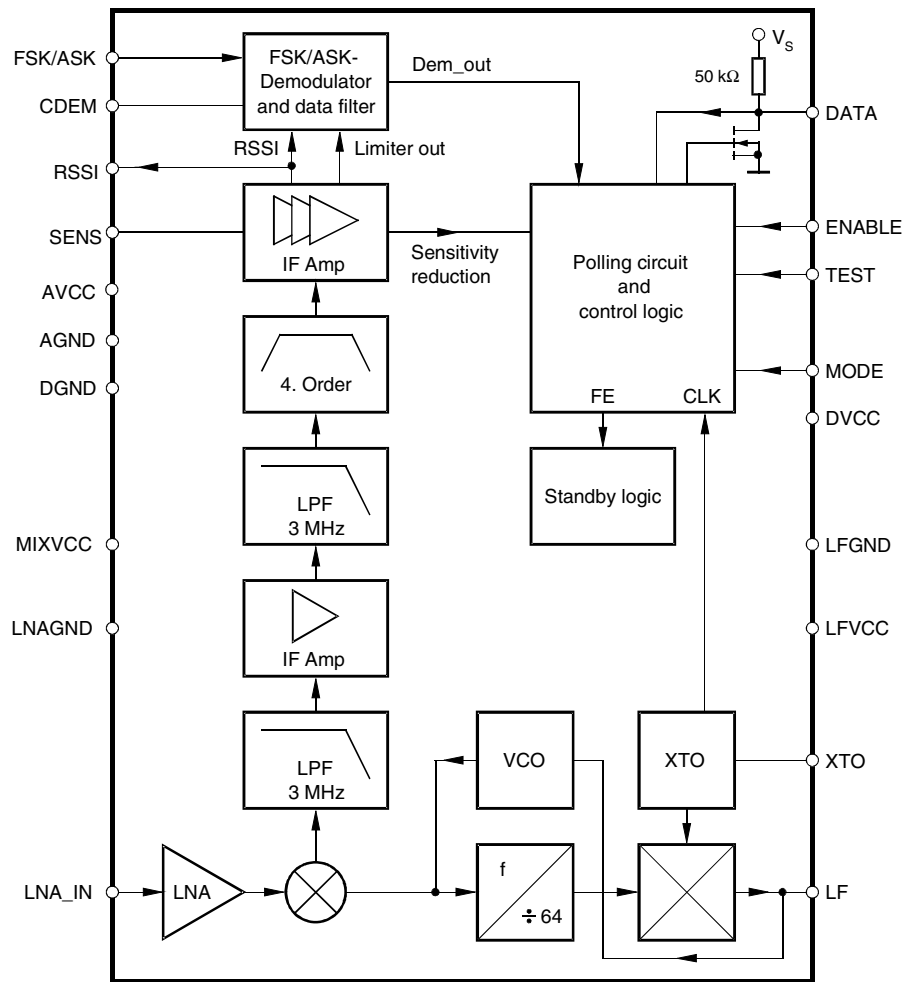
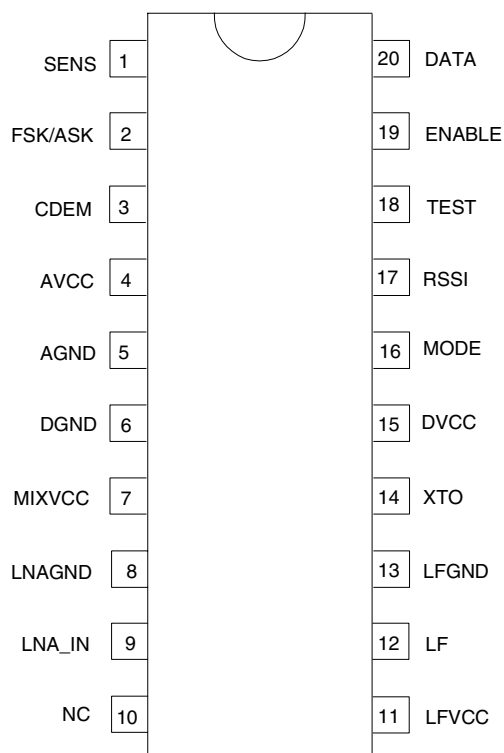

Figure 2. Block Diagram



Pin Configuration

Figure 3. Pinning SO20



Pin Description

Pin	Symbol	Function
1	SENS	Sensitivity-control resistor
2	FSK/ASK	Selecting FSK/ASK Low: FSK, High: ASK
3	CDEM	Lower cut-off frequency of the data filter
4	AVCC	Analog power supply
5	AGND	Analog ground
6	DGND	Digital ground
7	MIXVCC	Power supply mixer
8	LNAGND	High-frequency ground LNA and mixer
9	LNA_IN	RF input
10	NC	Not connected
11	LFVCC	Power supply VCO
12	LF	Loop filter
13	LFGND	Ground VCO
14	XTO	Crystal oscillator
15	DVCC	Digital power supply

Pin Description (Continued)

Pin	Symbol	Function
16	MODE	Selecting 433.92 MHz/315 MHz Low: 4.90625 MHz (USA) High: 6.76438 (Europe)
17	RSSI	Output of the RSSI amplifier
18	TEST	Test pin, during operation at GND
19	ENABLE	Enables the polling mode Low: polling mode off (sleep mode) High: polling mode on (active mode)
20	DATA	Data output/configuration input

RF Front End

The RF front end of the receiver is a heterodyne configuration that converts the input signal into a 1 MHz IF signal. According to Figure 2 on page 2, the front end consists of an LNA (low noise amplifier), LO (local oscillator), a mixer and an RF amplifier.

The LO generates the carrier frequency for the mixer via a PLL synthesizer. The XTO (crystal oscillator) generates the reference frequency f_{XTO} . The VCO (voltage-controlled oscillator) generates the drive voltage frequency f_{LO} for the mixer. f_{LO} is dependent on the voltage at pin LF. f_{LO} is divided by a factor of 64. The divided frequency is compared to f_{XTO} by the phase frequency detector. The current output of the phase frequency detector is connected to a passive loop filter and thereby generates the control voltage V_{LF} for the VCO. By means of that configuration, V_{LF} is controlled in a way that $f_{LO}/64$ is equal to f_{XTO} . If f_{LO} is determined, f_{XTO} can be calculated using the following formula:

$$f_{XTO} = f_{LO}/64$$

The XTO is a one-pin oscillator that operates at the series resonance of the quartz crystal. According to Figure 4, the crystal should be connected to GND via the capacitor C_L . The value of that capacitor is recommended by the crystal supplier. The value of C_L should be optimized for the individual board layout to achieve the exact value of f_{XTO} and hereby of f_{LO} . When designing the system in terms of receiving bandwidth, the accuracy of the crystal and the XTO must be considered.

Figure 4. PLL Peripherals

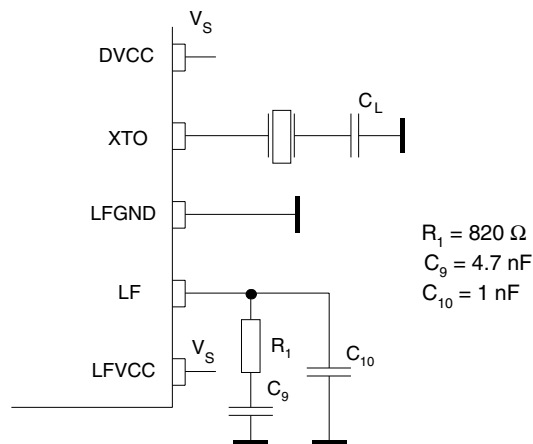

The passive loop filter connected to pin LF is designed for a loop bandwidth of $B_{Loop} = 100$ kHz. This value for B_{Loop} exhibits the best possible noise performance of the LO. Figure 4 on page 4 shows the appropriate loop filter components to achieve the desired loop bandwidth. If the filter components are changed for any reason, please note that the maximum capacitive load at pin LF is limited. If the capacitive load is exceeded, a bit check may no longer be possible since f_{LO} cannot settle in time before the bit check starts to evaluate the incoming data stream. Self-polling does therefore also not work in that case.

f_{LO} is determined by the RF input frequency f_{RF} and the IF frequency f_{IF} using the following formula:

$$f_{LO} = f_{RF} - f_{IF}$$

To determine f_{LO} , the construction of the IF filter must be considered at this point. The nominal IF frequency is $f_{IF} = 1$ MHz. To achieve a good accuracy of the filter's corner frequencies, the filter is tuned by the crystal frequency f_{XTO} . This means that there is a fixed relation between f_{IF} and f_{LO} , that depends on the logic level at pin MODE. This is described by the following formulas:

$$\text{MODE} = 0 \text{ (USA)} \quad f_{IF} = \frac{f_{LO}}{314}$$

$$\text{MODE} = 1 \text{ (Europe)} \quad f_{IF} = \frac{f_{LO}}{432.92}$$

The relation is designed to achieve the nominal IF frequency of $f_{IF} = 1$ MHz for most applications. For applications where $f_{RF} = 315$ MHz, MODE must be set to '0'. In the case of $f_{RF} = 433.92$ MHz, MODE must be set to '1'. For other RF frequencies, f_{IF} is not equal to 1 MHz. f_{IF} is then dependent on the logical level at pin MODE and on f_{RF} . Table 1 on page 6 summarizes the different conditions.

The RF input either from an antenna or from a generator must be transformed to the RF input pin LNA_IN. The input impedance of that pin is provided in the electrical parameters. The parasitic board inductances and capacitances also influence the input matching. The RF receiver U3742BM exhibits its highest sensitivity at the best signal-to-noise ratio in the LNA. Hence, noise matching is the best choice for designing the transformation network.

A good practice when designing the network is to start with power matching. From that starting point, the values of the components can be varied to some extent to achieve the best sensitivity.

If a SAW is implemented into the input network, a mirror frequency suppression of $\Delta P_{Ref} = 40$ dB can be achieved. There are SAWs available that exhibit a notch at $\Delta f = 2$ MHz. These SAWs work best for an intermediate frequency of IF = 1 MHz. The selectivity of the receiver is also improved by using a SAW. In typical automotive applications, a SAW is used.

Figure 5 on page 6 shows a typical input matching network for $f_{RF} = 315$ MHz and $f_{RF} = 433.92$ MHz using a SAW. Figure 6 on page 6 illustrates input matching to 50 Ω without a SAW. The input matching networks shown in Figure 6 on page 6 are the reference networks for the parameters given in the electrical characteristics.

Table 1. Calculation of LO and IF Frequency

Conditions	Local Oscillator Frequency	Intermediate Frequency
$f_{RF} = 315 \text{ MHz}$, MODE = 0	$f_{LO} = 314 \text{ MHz}$	$f_{IF} = 1 \text{ MHz}$
$f_{RF} = 433.92 \text{ MHz}$, MODE = 1	$f_{LO} = 432.92 \text{ MHz}$	$f_{IF} = 1 \text{ MHz}$
$300 \text{ MHz} < f_{RF} < 365 \text{ MHz}$, MODE = 0	$f_{LO} = \frac{f_{RF}}{1 + \frac{1}{314}}$	$f_{IF} = \frac{f_{LO}}{314}$
$365 \text{ MHz} < f_{RF} < 450 \text{ MHz}$, MODE = 1	$f_{LO} = \frac{f_{RF}}{1 + \frac{1}{432.92}}$	$f_{IF} = \frac{f_{LO}}{432.92}$

Figure 5. Input Matching Network with SAW Filter

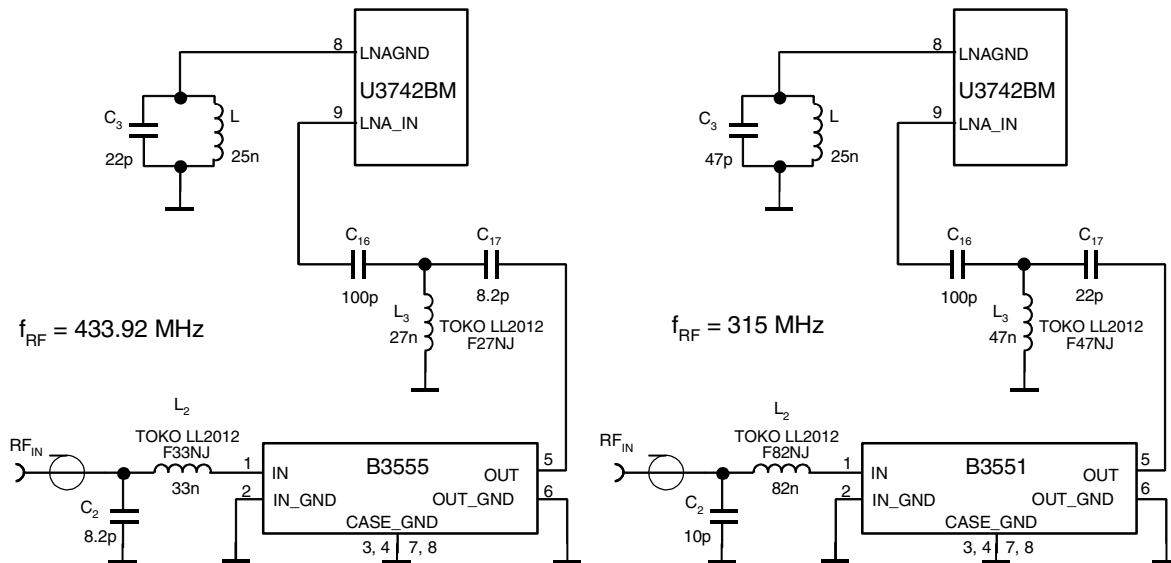
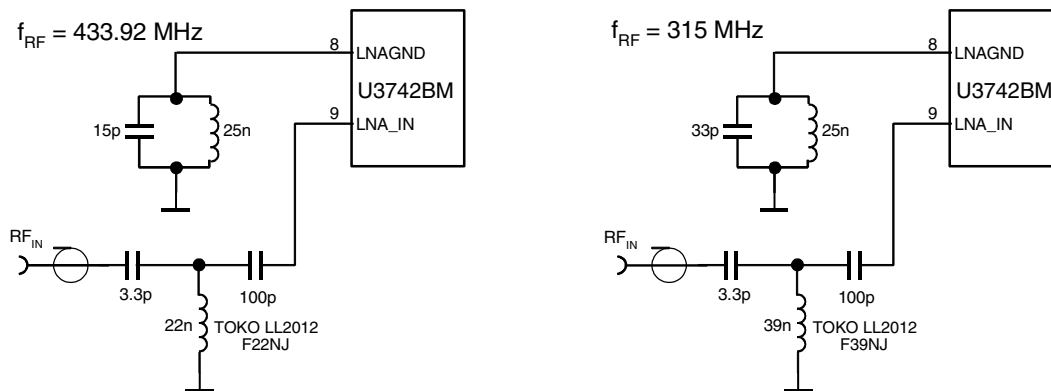

Figure 6. Input Matching Network without SAW Filter



Please note that for all coupling conditions (see Figure 5 on page 6 and Figure 6 on page 6), the bond wire inductivity of the LNA ground is compensated. C_3 forms a series resonance circuit together with the bond wire. $L = 25$ nH is a feed inductor to establish a DC path. Its value is not critical but must be large enough not to detune the series resonance circuit. For cost reduction, this inductor can be easily printed on the PCB. This configuration improves the sensitivity of the receiver by about 1 dB to 2 dB.

Analog Signal Processing

IF Amplifier

The signals coming from the RF front end are filtered by the fully integrated 4th-order IF filter. The IF center frequency is $f_{IF} = 1$ MHz for applications where $f_{RF} = 315$ MHz or $f_{RF} = 433.92$ MHz is used. For other RF input frequencies, refer to Table 1 on page 6 to determine the center frequency.

The receiver U3742BM - M3 employs an IF bandwidth of $B_{IF} = 600$ kHz and can be used together with the U2741B in FSK and ASK mode.

RSSI Amplifier

The subsequent RSSI amplifier enhances the output signal of the IF amplifier before it is fed into the demodulator. The dynamic range of this amplifier is $DR_{RSSI} = 60$ dB. If the RSSI amplifier is operated within its linear range, the best S/N ratio is maintained in ASK mode. If the dynamic range is exceeded by the transmitter signal, the S/N ratio is defined by the ratio of the maximum RSSI output voltage and the RSSI output voltage due to a disturber. The dynamic range of the RSSI amplifier is exceeded if the RF input signal is about 60 dB higher compared to the RF input signal at full sensitivity.

In FSK mode, the S/N ratio is not affected by the dynamic range of the RSSI amplifier.

The output voltage of the RSSI amplifier is internally compared to a threshold voltage V_{Th_red} . V_{Th_red} is determined by the value of the external resistor R_{Sense} . R_{Sense} is connected between pin SENS and GND or V_S . The output of the comparator is fed into the digital control logic. By this means it is possible to operate the receiver at a lower sensitivity.

Pin RSSI

The output voltage of the RSSI amplifier (V_{RSSI}) is available at pin RSSI. Using the RSSI output signal, the signal strength of different transmitters can be distinguished. The usable input-power range P_{Ref} is -100 dBm to -55 dBm. The temperature coefficient TC of V_{RSSI} is typically -2.2 mV/K. Due to TC and gain tolerance, it is not possible to find out the absolute level of each transmitter, but the level differences can be used to distinguish several transmitters. As illustrated in Figure 8 on page 8, the RSSI output voltage is not constant over the temperature range. Figure 7 on page 8 illustrates an application that realizes a temperature compensation of V_{RSSI} .

Figure 7. Temperature Compensation of V_{RSSI}

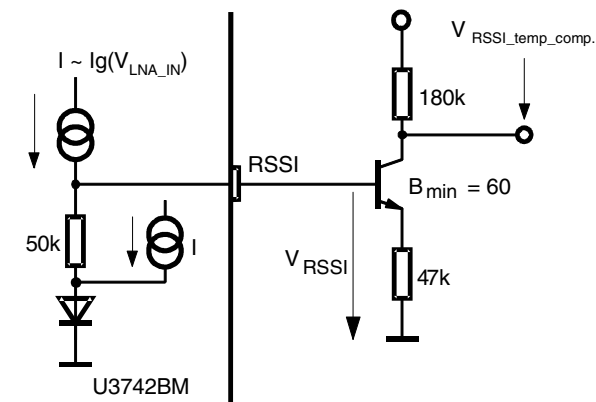
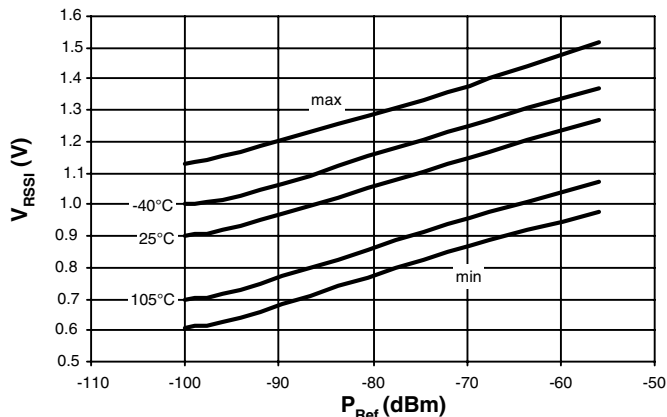

Figure 8. RSSI Characteristic



If R_{Sense} is connected to V_S , the receiver operates at a lower sensitivity. The reduced sensitivity is defined by the value of R_{Sense} , the maximum sensitivity by the signal-to-noise ratio of the LNA input. The reduced sensitivity is dependent on the signal strength at the output of the RSSI amplifier.

Since different RF input networks may exhibit slightly different values for the LNA gain, the sensitivity values given in the electrical characteristics refer to a specific input matching. This matching is illustrated in Figure 6 on page 6 and exhibits the best possible sensitivity.

R_{Sense} can be connected to V_S or GND via a microcontroller. The receiver can be switched from full sensitivity to reduced sensitivity or vice versa at any time. In polling mode, the receiver will not wake up if the RF input signal does not exceed the selected sensitivity. If the receiver is already active, the data stream at pin DATA will disappear when the input signal is lower than defined by the reduced sensitivity. Instead of the data stream, the pattern according to Figure 9 on page 9 is issued at pin DATA to indicate that the receiver is still active.

Figure 9. Steady L State Limited DATA Output Pattern

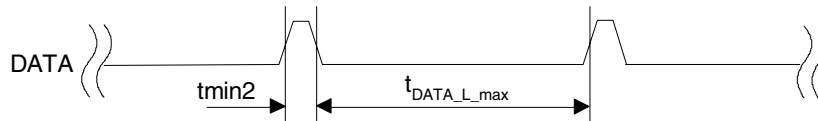

FSK/ASK Demodulator and Data Filter

The signal coming from the RSSI amplifier is converted into the raw data signal by the ASK/FSK demodulator. The operating mode of the demodulator is set via pin ASK/FSK. Logic 'L' sets the demodulator to FSK, Logic 'H' sets it into ASK mode.

In ASK mode, an automatic threshold control circuit (ATC) is employed to set the detection reference voltage to a value where a good signal-to-noise ratio is achieved. This circuit also implies the effective suppression of any kind of inband noise signals or competing transmitters. If the S/N ratio exceeds 10 dB, the data signal can be detected properly.

The FSK demodulator is intended to be used for an FSK deviation of $\Delta f \geq 20$ kHz. Lower values may be used but the sensitivity of the receiver is reduced in that condition. The minimum usable deviation is dependent on the selected baud rate. In FSK mode, only BR_Range0 and BR_Range1 are available. In FSK mode, the data signal can be detected if the S/N Ratio exceeds 2 dB.

The output signal of the demodulator is filtered by the data filter before it is fed into the digital signal processing circuit. The data filter improves the S/N ratio as its pass band can be adopted to the characteristics of the data signal. The data filter consists of a 1st-order high-pass and a 1st-order low-pass filter.

The high-pass filter cut-off frequency is defined by an external capacitor connected to pin CDEM. The cut-off frequency of the high-pass filter is defined by the following formula:

$$f_{cu_DF} = \frac{1}{2 \times \pi \times 30 \text{ k}\Omega \times \text{CDEM}}$$

In self-polling mode, the data filter must settle very rapidly to achieve a low current consumption. Therefore, CDEM cannot be increased to very high values if self-polling is used. On the other hand, CDEM must be large enough to meet the data filter requirements according to the data signal. Recommended values for CDEM are given in “Electrical Characteristics” on page 25. The values are slightly different for ASK and FSK mode.

The cut-off frequency of the low-pass filter is defined by the selected baud rate range (BR_Range). BR_Range is defined in the OPMODE register (refer to section “Configuration of the Receiver” on page 19). BR_Range must be set in accordance to the used baud rate.

The U3742BM is designed to operate with data coding where the DC level of the data signal is 50%. This is valid for Manchester and Bi-phase coding. If other modulation schemes are used, the DC level should always remain within the range of $V_{DC_min} = 33\%$ and $V_{DC_max} = 66\%$. The sensitivity may be reduced by up to 1.5 dB in that condition.

Each BR_Range is also defined by a minimum and a maximum edge-to-edge time (tee_sig). These limits are defined in the electrical characteristics. They should not be exceeded to maintain full sensitivity of the receiver.

Receiving Characteristics

The RF receiver U3742BM can be operated with and without a SAW front-end filter. In a typical automotive application, a SAW filter is used to achieve better selectivity. The selectivity with and without a SAW front-end filter is illustrated in Figure 10. This example relates to ASK mode. FSK mode exhibits similar behavior. Note that the mirror frequency is reduced by 40 dB. The plots are printed relatively to the maximum sensitivity. If a SAW filter is used, an insertion loss of about 4 dB must be considered.

When designing the system in terms of receiving bandwidth, the LO deviation must be considered as it also determines the IF center frequency. The total LO deviation is calculated to be the sum of the deviation of the crystal and the XTO deviation of the U3742BM. Low-cost crystals are specified to be within ± 100 ppm. The XTO deviation of the U3742BM is an additional deviation due to the XTO circuit. This deviation is specified to be ± 30 ppm. If a crystal of ± 100 ppm is used, the total deviation is ± 130 ppm in that case. Note that the receiving bandwidth and the IF-filter bandwidth are equivalent in ASK mode but not in FSK mode.

Figure 10. Receiving Frequency Response

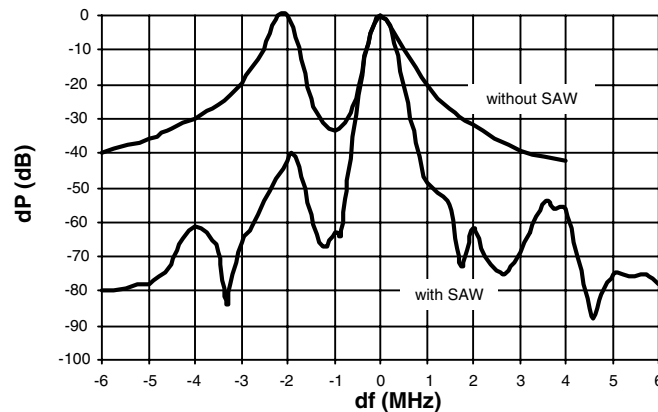

Polling Circuit and Control Logic

The receiver is designed to consume less than 1 mA while being sensitive to signals from a corresponding transmitter. This is achieved via the polling circuit. This circuit enables the signal path periodically for a short time. During this time the bit check logic verifies the presence of a valid transmitter signal. Only if a valid signal is detected the receiver remains active and transfers the data to the connected microcontroller. If there is no valid signal present, the receiver is in sleep mode most of the time resulting in low current consumption. This condition is called polling mode. A connected microcontroller is disabled during that time.

All relevant parameters of the polling logic can be configured by the connected microcontroller. This flexibility enables the user meets the specifications in terms of current consumption, system response time, data rate etc.

Regarding the number of connection wires to the microcontroller, the receiver is very flexible. It can be either operated by a single bi-directional line to save ports to the connected microcontroller, or it can be operated by up to three uni-directional ports.

Basic Clock Cycle of the Digital Circuitry

The complete timing of the digital circuitry and the analog filtering is derived from one clock. According to Figure 11, this clock cycle T_{CLK} is derived from the crystal oscillator (XTO) in combination with a divider. The division factor is controlled by the logical state at pin MODE. According to section “RF Front End” on page 4, the frequency of the crystal oscillator (f_{XTO}) is defined by the RF input signal (f_{RFIn}) which also defines the operating frequency of the local oscillator (f_{LO}).

Figure 11. Generation of the Basic Clock Cycle

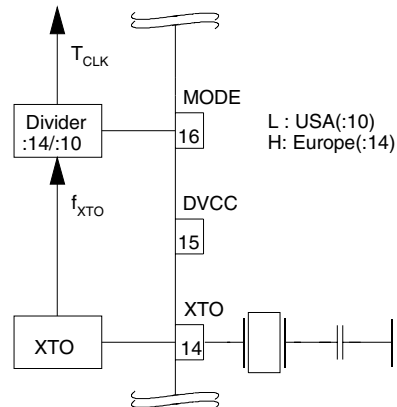

Pin MODE can now be set in accordance with the desired clock cycle T_{CLK} . T_{CLK} controls the following application-relevant parameters:

- Timing of the polling circuit including bit check
- Timing of the analog and digital signal processing
- Timing of the register programming
- Frequency of the reset marker
- IF filter center frequency (f_{IF0})

Most applications are dominated by two transmission frequencies: $f_{Send} = 315$ MHz is mainly used in the USA, $f_{Send} = 433.92$ MHz in Europe. In order to ease the usage of all T_{CLK} -dependent parameters, the electrical characteristics display three conditions for each parameter.

- Application USA ($f_{XTO} = 4.90625$ MHz, MODE = L, $T_{CLK} = 2.0383$ μ s)
- Application Europe ($f_{XTO} = 6.76438$ MHz, MODE = H, $T_{CLK} = 2.0697$ μ s)
- Other applications (T_{CLK} is dependent on f_{XTO} and on the logical state of pin MODE. The electrical characteristic is given as a function of T_{CLK}).

The clock cycle of some function blocks depends on the selected baud rate range (BR_Range) which is defined in the OPMODE register. This clock cycle T_{XCLK} is defined by the following formulas for further reference:

BR_Range =	BR_Range0:	$T_{XCLK} = 8 \times T_{CLK}$
	BR_Range1:	$T_{XCLK} = 4 \times T_{CLK}$
	BR_Range2:	$T_{XCLK} = 2 \times T_{CLK}$
	BR_Range3:	$T_{XCLK} = 1 \times T_{CLK}$

Polling Mode

According to Figure 13 on page 14, the receiver stays in polling mode in a continuous cycle of three different modes. In sleep mode, the signal processing circuitry is disabled for the time period T_{Sleep} while consuming low current of $I_S = I_{\text{Soff}}$. During the start-up period, T_{Startup} , all signal processing circuits are enabled and settled. In the following bit check mode, the incoming data stream is analyzed bit by bit contra a valid transmitter signal. If no valid signal is present, the receiver is set back to sleep mode after the period T_{Bitcheck} . This period varies check by check as it is a statistical process. An average value for T_{Bitcheck} is given in the electrical characteristics. During T_{Startup} and T_{Bitcheck} the current consumption is $I_S = I_{\text{Son}}$. The average current consumption in polling mode is dependent on the duty cycle of the active mode and can be calculated as:

$$I_{\text{Spoll}} = \frac{I_{\text{Soff}} \times T_{\text{Sleep}} + I_{\text{Son}} \times (T_{\text{Startup}} + T_{\text{Bitcheck}})}{T_{\text{Sleep}} + T_{\text{Startup}} + T_{\text{Bitcheck}}}$$

During T_{Sleep} and T_{Startup} , the receiver is not sensitive to a transmitter signal. To guarantee the reception of a transmitted command, the transmitter must start the telegram with an adequate preburst. The required length of the preburst is dependent on the polling parameters T_{Sleep} , T_{Startup} , T_{Bitcheck} and the startup time of a connected microcontroller ($T_{\text{Start,microcontroller}}$). T_{Bitcheck} thus depends on the actual bit rate and the number of bits (N_{Bitcheck}) to be tested.

The following formula indicates how to calculate the preburst length.

$$T_{\text{Purburst}} \geq T_{\text{Sleep}} + T_{\text{Startup}} + T_{\text{Bitcheck}} + T_{\text{Start_microcontroller}}$$

Sleep Mode

The length of period T_{Sleep} is defined by the 5-bit word Sleep of the OPMODE register, the extension factor X_{Sleep} , according to Table 8 on page 21, and the basic clock cycle T_{Clk} . It is calculated to be:

$$T_{\text{Sleep}} = \text{Sleep} \times X_{\text{Sleep}} \times 1024 \times T_{\text{Clk}}$$

In US- and European applications, the maximum value of T_{Sleep} is about 60 ms if X_{Sleep} is set to 1. The time resolution is about 2 ms in that case. The sleep time can be extended to almost half a second by setting X_{Sleep} to 8. X_{Sleep} can be set to 8 by bit X_{SleepStd} or by bit $X_{\text{SleepTemp}}$ resulting in a different mode of action as described below:

$X_{\text{SleepStd}} = 1$ implies the standard extension factor. The sleep time is always extended.

$X_{\text{SleepTemp}} = 1$ implies the temporary extension factor. The extended sleep time is used as long as every bit check is OK. If the bit check fails once, this bit is set back to 0 automatically resulting in a regular sleep time. This functionality can be used to save current in the presence of a modulated disturber similar to an expected transmitter signal. The connected microcontroller is rarely activated in that condition. If the disturber disappears, the receiver switches back to regular polling and is again sensitive to appropriate transmitter signals.

According to Table 7 on page 21, the highest register value of Sleep sets the receiver into a permanent sleep condition. The receiver remains in that condition until another value for Sleep is programmed into the OPMODE register. This function is desirable where several devices share a single data line.

Bit Check Mode

In bit check mode, the incoming data stream is examined to distinguish between a valid signal from a corresponding transmitter and signals due to noise. This is done by subsequent time frame checks where the distances between 2 signal edges are continuously compared to a programmable time window. The maximum count of these edge-to-edge tests, before the receiver switches to receiving mode, is also programmable.

Configuring the Bit Check

Assuming a modulation scheme that contains 2 edges per bit, two time frame checks are verifying one bit. This is valid for Manchester, bi-phase and most other modulation schemes. The maximum count of bits to be checked can be set to 0, 3, 6 or 9 bits via the variable N_{Bitcheck} in the OPMODE register. This implies 0, 6, 12 and 18 edge-to-edge checks respectively. If N_{Bitcheck} is set to a higher value, the receiver is less likely to switch to receiving mode due to noise. In the presence of a valid transmitter signal, the bit check takes less time if N_{Bitcheck} is set to a lower value. In polling mode, the bit check time is not dependent on N_{Bitcheck} . Figure 11 on page 11 shows an example where 3 bits are tested successfully and the data signal is transferred to pin DATA.

According to Figure 12, the time window for the bit check is defined by two separate time limits. If the edge-to-edge time t_{ee} is in between the lower bit check limit $T_{\text{Lim_min}}$ and the upper bit check limit $T_{\text{Lim_max}}$, the check will be continued. If t_{ee} is smaller than $T_{\text{Lim_min}}$ or t_{ee} exceeds $T_{\text{Lim_max}}$, the bit check will be terminated and the receiver switches to sleep mode.

Figure 12. Valid Time Window for Bit Check

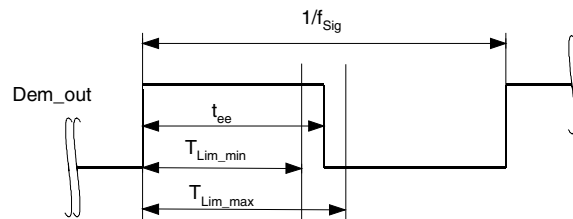

For best noise immunity it is recommended to use a low span between $T_{\text{Lim_min}}$ and $T_{\text{Lim_max}}$. This is achieved using a fixed frequency at a 50% duty cycle for the transmitter preburst. A '11111...' or a '10101...' sequence in Manchester or bi-phase is a good choice concerning that advice. A good compromise between receiver sensitivity and susceptibility to noise is a time window of $\pm 25\%$ regarding the expected edge-to-edge time t_{ee} . Using preburst patterns that contain various edge-to-edge time periods, the bit check limits must be programmed according to the required span.

The bit check limits are determined by means of the formula below:

$$T_{\text{Lim_min}} = \text{Lim_min} \times T_{\text{XClk}}$$

$$T_{\text{Lim_max}} = (\text{Lim_max} - 1) \times T_{\text{XClk}}$$

Lim_min and Lim_max are defined by a 5-bit word each within the LIMIT register.

Using above formulas, Lim_min and Lim_max can be determined according to the required $T_{\text{Lim_min}}$, $T_{\text{Lim_max}}$ and T_{XClk} . The time resolution when defining $T_{\text{Lim_min}}$ and $T_{\text{Lim_max}}$ is T_{XClk} . The minimum edge-to-edge time t_{ee} ($t_{\text{DATA_L_min}}$, $t_{\text{DATA_H_min}}$) is defined according to the section "Receiving Mode" on page 16. Due to this, the lower limit should be set to $\text{Lim_min} \geq 10$. The maximum value of the upper limit is $\text{Lim_max} = 63$.

Figure 13. Polling Mode Flow Chart

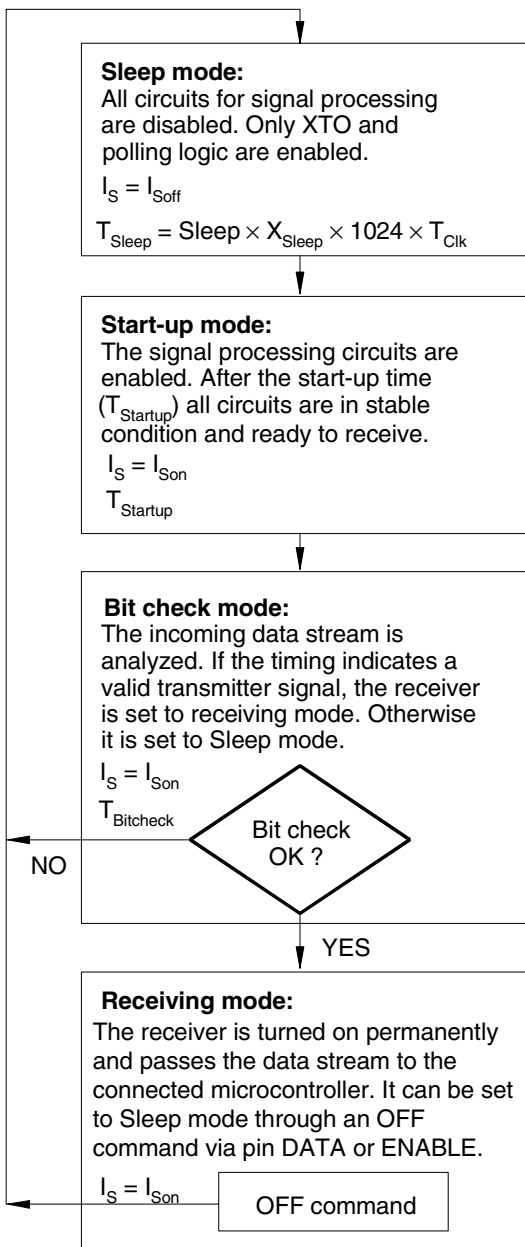

Sleep: 5-bit word defined by Sleep0 to Sleep4 in OPMODE register

X_{Sleep} : Extension factor defined by $X_{Sleep_{Std}}$ and $X_{Sleep_{Temp}}$ according to Table 8

T_{CLK} : Basic clock cycle defined by f_{XTO} and pin MODE

$T_{Startup}$: Is defined by the selected baud rate range and T_{Clk} . The baud rate range is defined by Baud0 and Baud1 in the OPMODE register.

$T_{Bitcheck}$: Depends on the result of the bit check
If the bit check is ok, $T_{bitcheck}$ depends on the number of bits to be checked ($N_{Bitcheck}$) and on the utilized data rate.

If the bit check fails, the average time period for that check depends on the selected baud rate range and on T_{Clk} . The baud rate is defined by Baud0 and Baud1 in the OPMODE register.

Figure 14. Timing Diagram for Complete Successful Bit Check

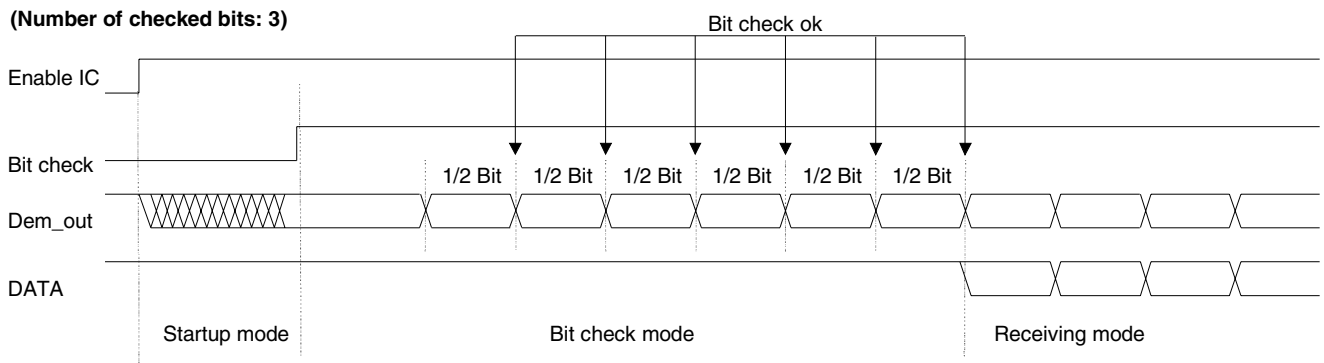

Figure 15. Timing Diagram During Bit Check

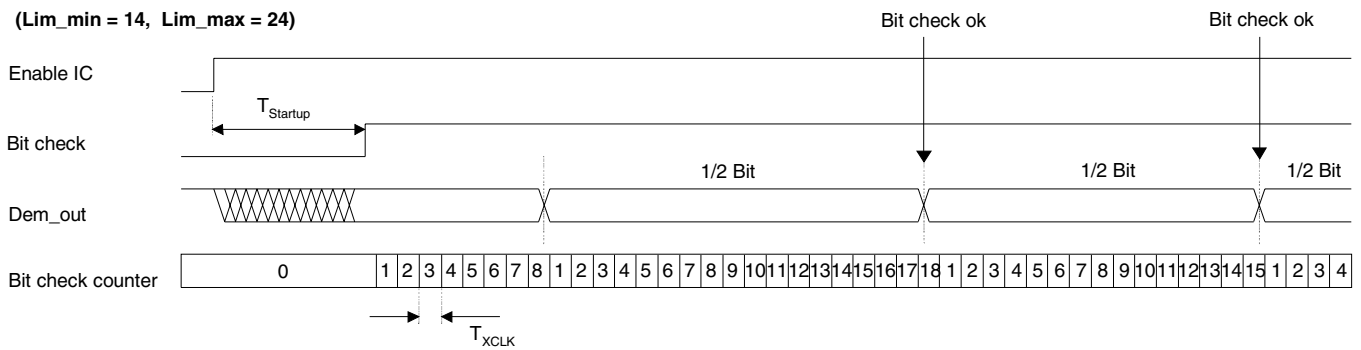

Figure 16. Timing Diagram for Failed Bit Check (Condition: CV_Lim < Lim_min)

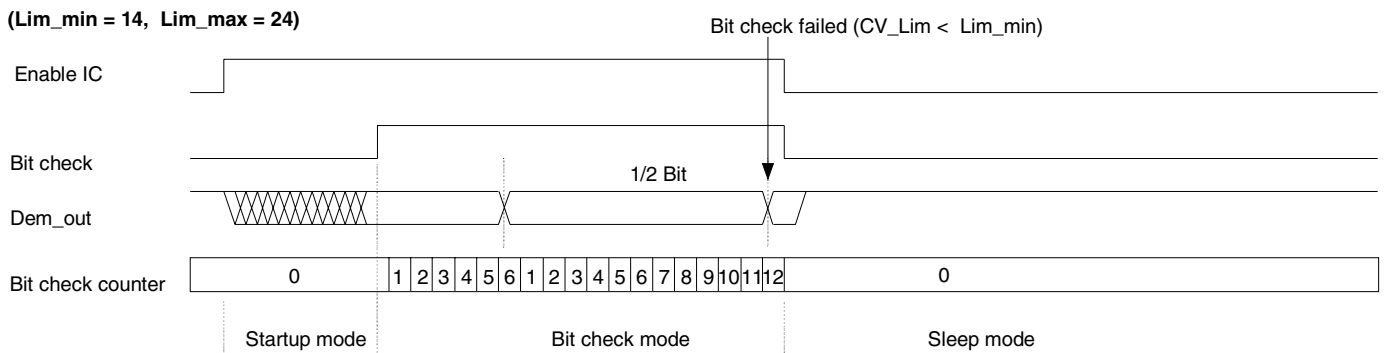

Figure 17. Timing Diagram for Failed Bit Check (Condition: $CV_Lim \geq Lim_max$)

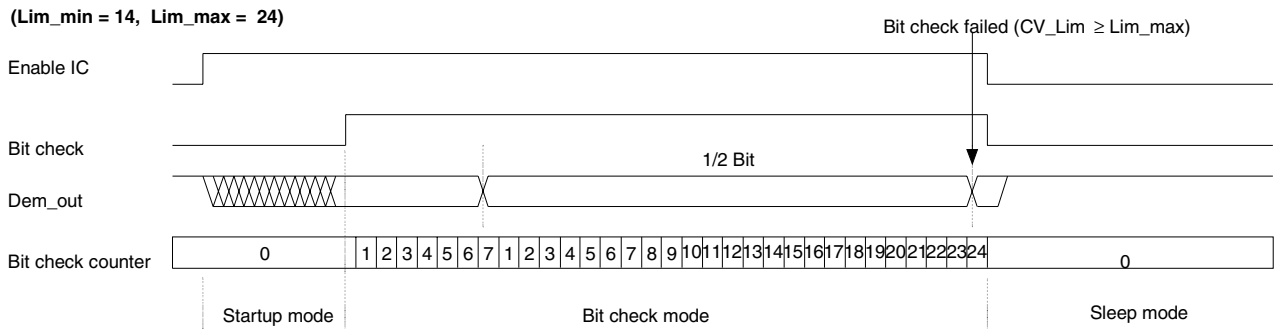

Figure 15 to Figure 17 illustrate the bit check for the default bit check limits $Lim_min = 14$ and $Lim_max = 24$. When the IC is enabled, the signal processing circuits are enabled during $T_{Startup}$. The output of the ASK/FSK demodulator (Dem_out) is undefined during that period. When the bit check becomes active, the bit check counter is clocked with the cycle T_{XClk} .

Figure 15 on page 15 shows how the bit check proceeds if the bit check counter value CV_Lim is within the limits defined by Lim_min and Lim_max at the occurrence of a signal edge. In Figure 16 on page 15, the bit check fails as the value CV_lim is lower than the limit Lim_min . The bit check also fails if CV_Lim reaches Lim_max . This is illustrated in Figure 17.

Duration of the Bit Check

If no transmitter signal is present during the bit check, the output of the ASK/FSK demodulator delivers random signals. The bit check is a statistical process and $T_{Bitcheck}$ varies for each check. Therefore, an average value for $T_{Bitcheck}$ is given in the electrical characteristics. $T_{Bitcheck}$ depends on the selected baud rate range and on T_{Clk} . A higher baud rate range causes a lower value for $T_{Bitcheck}$ resulting in a lower current consumption in polling mode.

In the presence of a valid transmitter signal, $T_{Bitcheck}$ is dependant on the frequency of that signal, f_{Sig} and the count of the checked bits, $N_{Bitcheck}$. A higher value for $N_{Bitcheck}$ thereby results in a longer period for $T_{Bitcheck}$ requiring a higher value for the transmitter preburst $T_{Preburst}$.

Receiving Mode

If the bit check has been successful for all bits specified by $N_{Bitcheck}$, the receiver switches to receiving mode. According to Figure 14, the internal data signal is switched to pin DATA in that case. A connected microcontroller can be woken up by the negative edge at pin DATA. The receiver stays in that condition until it is switched back to polling mode explicitly.

Digital Signal Processing

The data from the ASK/FSK demodulator (Dem_out) is digitally processed in different ways and as a result converted into the output signal data. This processing depends on the selected baud rate range (BR_Range). Figure 18 on page 17 illustrates how Dem_out is synchronized by the extended clock cycle T_{XClk} . This clock is also used for the bit check counter. Data can change its state only after T_{XClk} elapsed. The edge-to-edge time period t_{ee} of the Data signal as a result is always an integral multiple of T_{XClk} .

The minimum time period between two edges of the data signal is limited to $t_{ee} \geq T_{DATA_min}$. This implies an efficient suppression of spikes at the DATA output. At the same time, it limits the maximum frequency of edges at DATA. This eases the interrupt handling of a connected microcontroller. T_{DATA_min} is to some extent affected by the preceding edge-to-edge time interval t_{ee} as illustrated in Figure 19. If t_{ee} is in between the specified bit check limits, the following level is frozen for the time period $T_{DATA_min} = t_{min1}$, in case of t_{ee} being outside that bit check limits $T_{DATA_min} = t_{min2}$ is the relevant stable time period.

The maximum time period for DATA to be Low is limited to $T_{DATA_L_max}$. This function ensures a finite response time during programming or switching off the receiver via pin DATA. $T_{DATA_L_max}$ is thereby longer than the maximum time period indicated by the transmitter data stream. Figure 20 gives an example where Dem_out remains Low after the receiver is in receiving mode.

Figure 18. Synchronization of the Demodulator Output

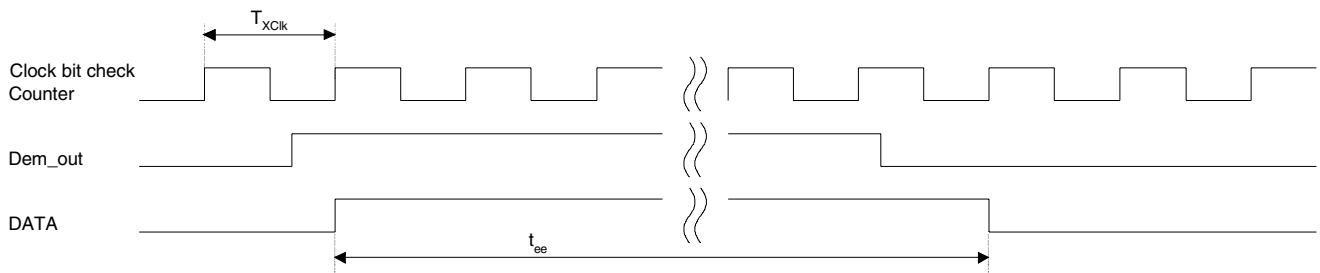

Figure 19. Debouncing of the Demodulator Output

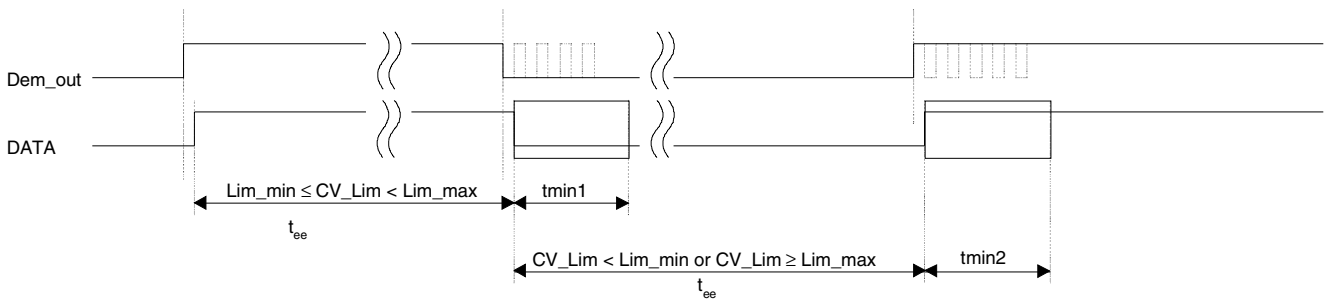
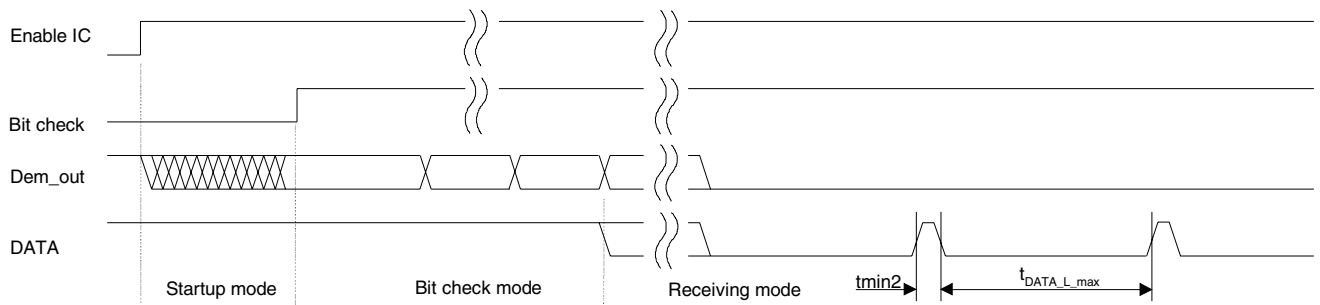

Figure 20. Steady L State Limited DATA Output Pattern after Transmission



After the end of data transmission, the receiver remains active and random noise pulses appear at pin DATA. The edge-to-edge time period t_{ee} of the majority of these noise pulses is equal to or slightly higher than T_{DATA_min} .

Switching the Receiver Back to Sleep Mode

The receiver can be set back to polling mode via pin DATA or via pin ENABLE.

When using pin DATA, this pin must be pulled to Low for the period t_1 by the connected microcontroller. Figure 21 illustrates the timing of the OFF command (see also Figure 25 on page 23). The minimum value of t_1 depends on BR_Range. The maximum value for t_1 is not limited but it is recommended not to exceed the specified value to prevent erasing the reset marker. This item is explained in more detail in the section "Configuration of the Receiver" on page 19. Setting the receiver to sleep mode via DATA is achieved by programming bit 1 of the OPMODE register to be '1'. Only one sync pulse (t_3) is issued.

The duration of the OFF command is determined by the sum of t_1 , t_2 and t_{10} . After the OFF command, the sleep time T_{Sleep} elapses. Note that the capacitive load at pin DATA is limited. The resulting time constant τ together with an optional external pull-up resistor may not be exceeded to ensure proper operation.

If the receiver is set to polling mode via pin ENABLE, an 'L' pulse (T_{Doze}) must be issued at that pin. Figure 22 on page 19 illustrates the timing of that command. After the positive edge of this pulse, the sleep time T_{Sleep} elapses. The receiver remains in sleep mode as long as ENABLE is held to 'L'. If the receiver is polled exclusively by a microcontroller, T_{Sleep} can be programmed to 0 to enable a instantaneous response time. This command is the faster option than via pin DATA at the cost of an additional connection to the microcontroller.

Figure 21. Timing Diagram of the OFF-command via Pin DATA

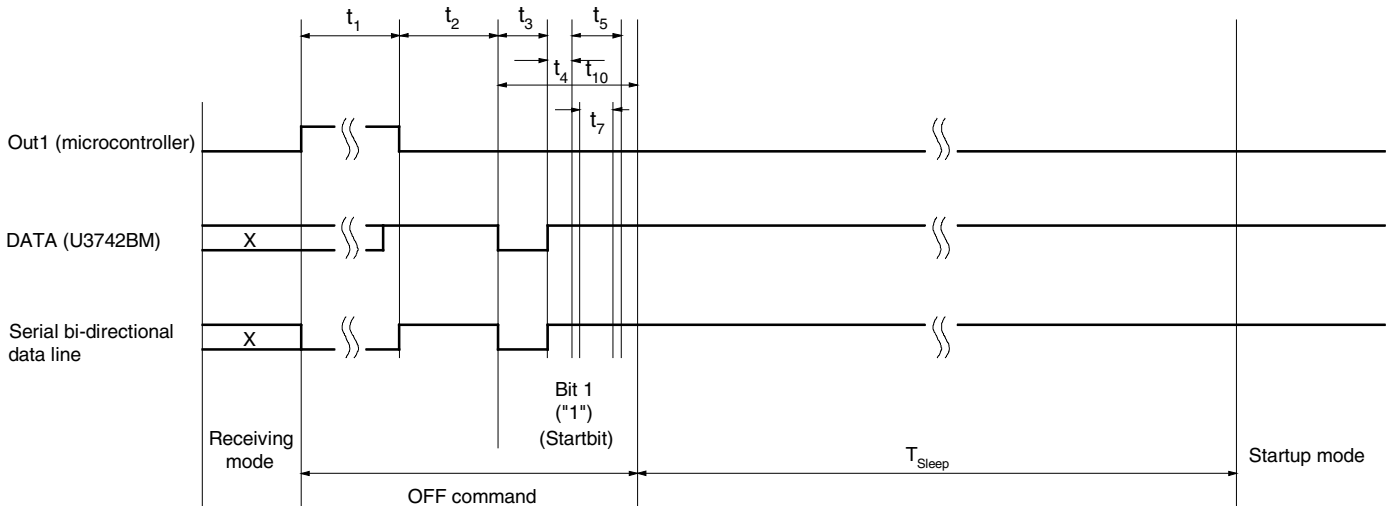
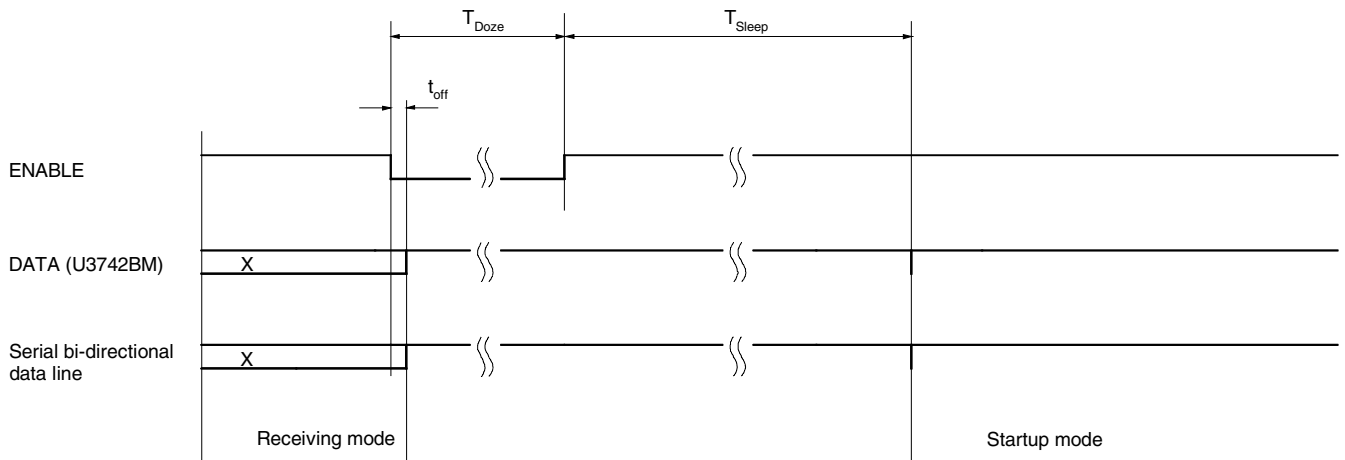

Figure 22. Timing Diagram of the OFF-command via Pin ENABLE



Configuration of the Receiver

The U3742BM receiver is configured via two 12-bit RAM registers called OPMODE and LIMIT. The registers can be programmed by means of the bi-directional DATA port. If the register contents have changed due to a voltage drop, this condition is indicated by a certain output pattern called reset marker (RM). The receiver must be reprogrammed in that case. After a power-on reset (POR), the registers are set to default mode. If the receiver is operated in default mode, there is no need to program the registers.

Table 3 on page 20 shows the structure of the registers. According to Table 2, bit 1 defines if the receiver is set back to polling mode via the OFF command, (see section “Receiving Mode” on page 16) or if it is programmed. Bit 2 represents the register address. It selects the appropriate register to be programmed.

Table 2. Effect of Bit 1 and Bit 2 in Programming the Registers

Bit 1	Bit 2	Action
1	x	The receiver is set back to polling mode (OFF command)
0	1	The OPMODE register is programmed
0	0	The LIMIT register is programmed

Table 4 on page 20 and the following illustrate the effect of the individual configuration words. The default configuration is highlighted for each word.

BR_Range sets the appropriate baud rate range. At the same time it defines XLim. XLim is used to define the bit check limits T_{Lim_min} and T_{Lim_max} as shown in Table 4 on page 20.

Table 3. Effect of the Configuration Words within the Registers

Bit 1	Bit 2	Bit 3	Bit 4	Bit 5	Bit 6	Bit 7	Bit 8	Bit 9	Bit 10	Bit 11	Bit 12	Bit 13	Bit 14
OFF Command													
1													
OPMODE Register													
0	1	BR_Range		N _{Bitcheck}		V _{POUT}	Sleep					XSleep	
0	1	Baud1	Baud0	BitChk1	BitChk0	POUT	Sleep4	Sleep3	Sleep2	Sleep1	Sleep0	X _{Sleep Std}	X _{Sleep Temp}
(Default)		0	0	1	0	0	0	1	0	1	1	0	0
LIMIT Register													
0	0	Lim_min						Lim_max					
0	0	Lim_min5	Lim_min4	Lim_min3	Lim_min2	Lim_min1	Lim_min0	Lim_max5	Lim_max4	Lim_max3	Lim_max2	Lim_max1	Lim_max0
(Default)		0	0	1	1	1	0	0	1	1	0	0	0

Table 4. Effect of the Configuration Word BR_Range

BR_Range		Baud Rate Range/Extension Factor for Bit Check Limits (XLim)
Baud1	Baud0	
0	0	BR_Range0 (application USA/Europe: BR_Range0 = 1.0 kBaud to 1.8 kBaud) (Default) XLim = 8 (Default)
0	1	BR_Range1 (application USA/Europe: BR_Range1 = 1.8 kBaud to 3.2 kBaud) XLim = 4
1	0	BR_Range2 (application USA/Europe: BR_Range2 = 3.2 kBaud to 5.6 kBaud) XLim = 2
1	1	BR_Range3 (Application USA/Europe: BR_Range3 = 5.6 kBaud to 10 kBaud) XLim = 1

Table 5. Effect of the Configuration Word N_{Bitcheck}

N _{Bitcheck}		Number of Bits to be Checked
BitChk1	BitChk0	
0	0	0
0	1	3
1	0	6 (Default)
1	1	9

Table 6. Effect of the Configuration Bit Reserved

Reserved Bit	No Function (Reserved for Future Use)
0	(Default)
1	

Table 7. Effect of the Configuration Word Sleep

Sleep					Start Value for Sleep Counter ($T_{Sleep} = Sleep \times X_{sleep} \times 1024 \times T_{Cik}$)
Sleep4	Sleep3	Sleep2	Sleep1	Sleep0	
0	0	0	0	0	0 (Receiver is continuously polling until a valid signal occurs)
0	0	0	0	1	1 ($T_{Sleep} \approx 2ms$ for $X_{Sleep} = 1$ in US/European applications)
0	0	0	1	0	2
0	0	0	1	1	3
.
.
.
0	1	0	1	1	11 (USA: $T_{Sleep} = 22.96 ms$, Europe: $T_{Sleep} = 23.31 ms$) (Default)
.
.
.
1	1	1	0	1	29
1	1	1	1	0	30
1	1	1	1	1	31 (Permanent sleep mode)

Table 8. Effect of the Configuration Word XSleep

XSleep		Extension Factor for Sleep Time ($T_{Sleep} = Sleep \times X_{sleep} \times 1024 \times T_{Cik}$)
XSleep _{Std}	XSleep _{Temp}	
0	0	1 (Default)
0	1	8 (XSleep is reset to 1 if bit check fails once)
1	0	8 (XSleep is set permanently)
1	1	8 (XSleep is set permanently)

Table 9. Effect of the Configuration Word Lim_min

Lim_min						Lower Limit Value for Bit Check ($T_{Lim_min} = Lim_min \times X_{Lim} \times T_{Cik}$)
Lim_min < 10 is not applicable						
0	0	1	0	1	0	10
0	0	1	0	1	1	11
0	0	1	1	0	0	12
0	0	1	1	0	1	13
0	0	1	1	1	0	14 (Default) (USA: $T_{Lim_min} = 228 \mu s$, Europe: $T_{Lim_min} = 232 \mu s$)
.
.
.
1	1	1	1	0	1	61
1	1	1	1	1	0	62
1	1	1	1	1	1	63

Table 10. Effect of the Configuration Word Lim_max

Lim_max						Upper Limit Value for Bit Check
Lim_max < 12 is not applicable						$(T_{Lim_max} = (Lim_max - 1) \times XLim \times T_{Cik})$
0	0	1	1	0	0	12
0	0	1	1	0	1	13
0	0	1	1	1	0	14
.	
0	1	1	0	0	0	24 (Default) (USA: $T_{Lim_max} = 375 \mu s$, Europe: $T_{Lim_max} = 381 \mu s$)
.	
1	1	1	1	0	1	61
1	1	1	1	1	0	62
1	1	1	1	1	1	63

Conservation of the Register Information

The U3742BM has an integrated power-on reset (POR) and brown-out detection circuitry to provide a mechanism to preserve the RAM register information.

According to Figure 23, a power-on reset is generated if the supply voltage V_S drops below the threshold voltage $V_{ThReset}$. The default parameters are programmed into the configuration registers in that condition. Once V_S exceeds $V_{ThReset}$, the POR is canceled after the minimum reset period t_{Rst} . A POR is also generated when the supply voltage of the receiver is turned on.

To indicate that condition, the receiver displays a reset marker (RM) at pin DATA after a reset. The RM is represented by the fixed frequency f_{RM} at a 50% duty cycle. RM can be canceled via an 'L' pulse t_1 at pin DATA. The RM implies the following characteristics:

- f_{RM} is lower than the lowest feasible frequency of a data signal. This means, RM cannot be misinterpreted by the connected microcontroller.
- If the receiver is set back to polling mode via pin DATA, RM cannot be cancelled by accident if t_1 is applied according to the proposal in the section "Programming the Configuration Register" on page 23.

By means of that mechanism, the receiver cannot lose its register information without communicating that condition via the reset marker RM.

Figure 23. Generation of the Power-on Reset

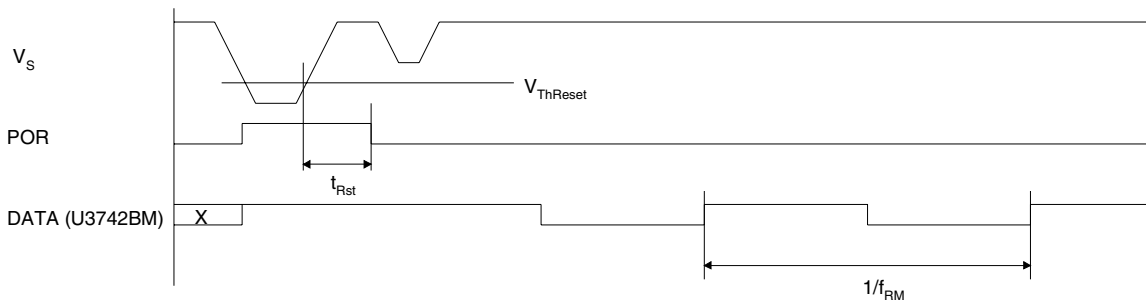
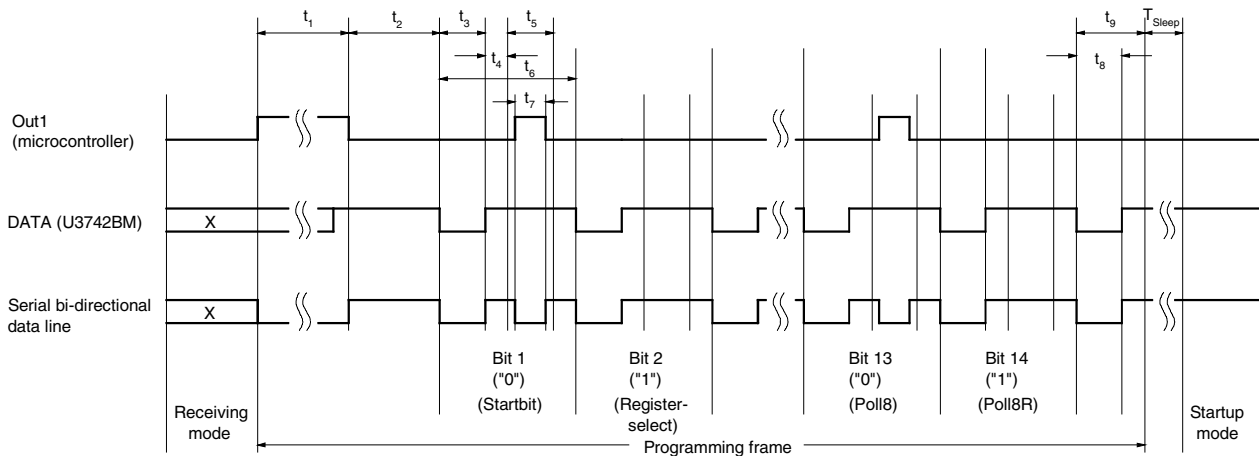

Figure 24. Timing of the Register Programming



Programming the Configuration Register

The configuration registers are programmed serially via the bi-directional data line according to Figure 24 and Figure 25.

Figure 25. One-wire Connection to a Microcontroller

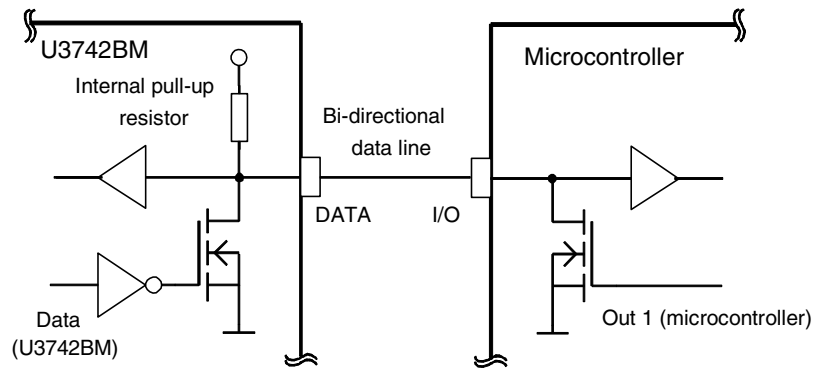

To start programming, the serial data line DATA is pulled to 'L' for the time period t_1 by the microcontroller. When DATA has been released, the receiver becomes the master device. When the programming delay period t_2 has elapsed, it emits 14 subsequent synchronization pulses with the pulse length t_3 . After each of these pulses, a programming window occurs. The delay until the program window starts is determined by t_4 , the duration is defined by t_5 . Within the programming window, the individual bits are set. If the microcontroller pulls down pin DATA for the time period t_7 during t_5 , the bit is set to '0'. If no programming pulse t_7 is issued, this bit is set to '1'. All 14 bits are subsequently programmed in this way. The time frame to program a bit is defined by t_6 .

Bit 14 is followed by the equivalent time window t_9 . During this window, the equivalent acknowledge pulse t_8 (E_Ack) occurs if the just programmed mode word is equivalent to the mode word that was already stored in that register. E_Ack should be used to verify that the mode word was correctly transferred to the register. The register must be programmed twice in that case.

Programming of a register is possible both during sleep and active mode of the receiver.

During programming, the LNA, LO, low-pass filter, IF-amplifier and the FSK/ASK Manchester demodulator are disabled.

The programming start pulse t_1 initiates the programming of the configuration registers. If bit 1 is set to '1', it represents the OFF-command to set the receiver back to polling mode at the same time. For the length of the programming start pulse t_1 , the following convention should be considered:

- $t_1(\text{min}) < t_1 < 1535 \times T_{\text{clk}}$; [$t_1(\text{min})$ is the minimum specified value for the relevant BR_Range]

Programming (respectively OFF-command) is initiated if the receiver is not in reset mode. If the receiver is in reset mode, programming (respectively Off-command) is not initiated, and the reset marker RM is still present at pin DATA.

This period is generally used to switch the receiver to polling mode. In a reset condition, RM is not canceled by accident.

- $t_1 > 5632 \times T_{\text{clk}}$

Programming (respectively OFF-command) is initiated in any case. RM is canceled if present.

This period is used if the connected microcontroller detected RM. If a configuration register is programmed, this time period for t_1 can generally be used. Note that the capacitive load at pin DATA is limited. The resulting time constant t together with an optional external pull-up resistor may not be exceeded to ensure proper operation.

Absolute Maximum Ratings

Stresses beyond those listed under “Absolute Maximum Ratings” may cause permanent damage to the device. This is a stress rating only and functional operation of the device at these or any other conditions beyond those indicated in the operational sections of this specification is not implied. Exposure to absolute maximum rating conditions for extended periods may affect device reliability.

Parameters	Symbol	Min.	Max.	Unit
Power dissipation	P_{tot}		450	mW
Junction temperature	T_j		150	°C
Storage temperature	T_{stg}	-55	+125	°C
Ambient temperature	T_{amb}	-40	+105	°C
Maximum input level, input matched to 50 W	$P_{\text{in_max}}$		10	dBm

Thermal Resistance

Parameters	Symbol	Value	Unit
Junction ambient	R_{thJA}	100	K/W

Electrical Characteristics

All parameters refer to GND, $T_{amb} = -40^{\circ}\text{C}$ to $+105^{\circ}\text{C}$, $V_S = 4.5\text{ V}$ to 5.5 V , $f_0 = 433.92\text{ MHz}$ and $f_0 = 315\text{ MHz}$, unless otherwise specified. ($V_S = 5\text{ V}$, $T_{amb} = 25^{\circ}\text{C}$)

Parameter	Test Condition	Symbol	6.76438 Mhz Oscillator (Mode 1)			4.90625 Mhz Oscillator (Mode 0)			Variable Oscillator			Unit
			Min.	Typ.	Max.	Min.	Typ.	Max.	Min.	Typ.	Max.	
Basic Clock Cycle of the Digital Circuitry												
Basic clock cycle	MODE = 0 (USA) MODE = 1 (Europe)	T_{Clk}		2.0697			2.0383			$1/(f_{XTO}/10)$ $1/(f_{XTO}/14)$		μs μs
Extended basic clock cycle	BR_Range0	T_{XClk}		16.6			16.3			$8 \times T_{Clk}$		μs
	BR_Range1			8.3			8.2			$4 \times T_{Clk}$		μs
	BR_Range2			4.1			4.1			$2 \times T_{Clk}$		μs
	BR_Range3			2.1			2.0			$1 \times T_{Clk}$		μs
Polling Mode												
Sleep time	Sleep and XSleep are defined in the OPMODE register	T_{Sleep}		$Sleep \times X_{Sleep} \times 1024 \times 2.0697$			$Sleep \times X_{Sleep} \times 1024 \times 2.0383$			$Sleep \times X_{Sleep} \times 1024 \times T_{Clk}$		ms
Start-up time	BR_Range0	$T_{Startup}$		1855			1827			896.5		μs
	BR_Range1			1061			1045			512.5		μs
	BR_Range2			1061			1045			512.5		μs
	BR_Range3			663			653			$320.5 \times T_{Clk}$		μs
Time for Bit Check	Average bit check time while polling	$T_{Bitcheck}$		0.45			0.47					ms
	BR_Range0			0.24			0.26					ms
	BR_Range1			0.14			0.16					ms
	BR_Range2			0.14			0.15					ms
	BR_Range3											ms
	Bit check time for a valid input signal f_{Sig}	$T_{Bitcheck}$							T_{XClk}		T_{XClk}	ms
	$N_{Bitcheck} = 0$								$3/f_{Sig}$		$3.5/f_{Sig}$	ms
	$N_{Bitcheck} = 3$								$6/f_{Sig}$		$6.5/f_{Sig}$	ms
	$N_{Bitcheck} = 6$								$9/f_{Sig}$		$9.5/f_{Sig}$	ms
	$N_{Bitcheck} = 9$											ms
Receiving Mode												
Intermediate frequency	MODE=0 (USA) MODE=1 (Europe)	f_{IF}		1.0			1.0			$f_{XTO} \times 64/314$ $f_{XTO} \times 64/432.92$		MHz MHz
Baud rate range	BR_Range0	BR_Range	1.0		1.8	1.0		1.8		$BR_Range0 \times 2 \mu\text{s}/T_{Clk}$		kBaud
	BR_Range1		1.8		3.2	1.8		3.2		$BR_Range1 \times 2 \mu\text{s}/T_{Clk}$		kBaud
	BR_Range2		3.2		5.6	3.2		5.6		$BR_Range2 \times 2 \mu\text{s}/T_{Clk}$		kBaud
	BR_Range3		5.6		10.0	5.6		10.0		$BR_Range3 \times 2 \mu\text{s}/T_{Clk}$		kBaud
Minimum time period between edges at pin DATA (Figure 19 on page 17)	BR_Range0	T_{DATA_min}	tmin1	149			147			$9 \times T_{XClk}$		μs
			tmin2	182			179			$11 \times T_{XClk}$		μs
	BR_Range1	T_{DATA_min}	tmin1	75			73			$9 \times T_{XClk}$		μs
			tmin2	91			90			$11 \times T_{XClk}$		μs
	BR_Range2	T_{DATA_min}	tmin1	37.3			36.7			$9 \times T_{XClk}$		μs
			tmin2	45.5			44.8			$11 \times T_{XClk}$		μs
	BR_Range3	T_{DATA_min}	tmin1	18.6			18.3			$9 \times T_{XClk}$		μs
			tmin2	22.8			22.4			$11 \times T_{XClk}$		μs

Electrical Characteristics (Continued)

All parameters refer to GND, $T_{amb} = -40^{\circ}\text{C}$ to $+105^{\circ}\text{C}$, $V_S = 4.5\text{ V}$ to 5.5 V , $f_0 = 433.92\text{ MHz}$ and $f_0 = 315\text{ MHz}$, unless otherwise specified. ($V_S = 5\text{ V}$, $T_{amb} = 25^{\circ}\text{C}$)

Parameter	Test Condition	Symbol	6.76438 Mhz Oscillator (Mode 1)			4.90625 Mhz Oscillator (Mode 0)			Variable Oscillator			Unit
			Min.	Typ.	Max.	Min.	Typ.	Max.	Min.	Typ.	Max.	
Maximum low period at DATA (Figure 20)	BR_Range0	$T_{DATA_L_max}$		2169			2136			$131 \times T_{XCLK}$		μs
	BR_Range1		1085		1068		$131 \times T_{XCLK}$		μs			
	BR_Range2		542		534		$131 \times T_{XCLK}$		μs			
	BR_Range3		271		267		$131 \times T_{XCLK}$		μs			
OFF command at pin ENABLE (Figure 22)		t_{Doze}	3.1			3.05			$1.5 \times T_{CLK}$		μs	
Configuration of the Receiver												
Frequency of the reset marker (Figure 23)		f_{RM}		117.9			119.8			$\frac{1}{4096 \times T_{CLK}}$		Hz
Programming start pulse (Figure 21, Figure 24)	BR_Range0	t_1	2188		3176	2155		3128	$1057 \times T_{CLK}$		$1535 \times T_{CLK}$	μs
	BR_Range1		1104		3176	1087		3128	$533 \times T_{CLK}$		$1535 \times T_{CLK}$	
	BR_Range2		561		3176	553		3128	$271 \times T_{CLK}$		$1535 \times T_{CLK}$	
	BR_Range3		290		3176	286		3128	$140 \times T_{CLK}$		$1535 \times T_{CLK}$	
	after POR		11656			11479			$5632 \times T_{CLK}$		T_{CLK}	
Programming delay period (Figure 21, Figure 24)		t_2	795		798	783		786	$384.5 \times T_{CLK}$		$385.5 \times T_{CLK}$	μs
Synchroni- zation pulse (Figure 21, Figure 24)		t_3		265			261			$128 \times T_{CLK}$		μs
Delay until the program window starts (Figure 21, Figure 24)		t_4		131			129			$63.5 \times T_{CLK}$		μs
Programming window (Figure 21, Figure 24)		t_5		530			522			$256 \times T_{CLK}$		μs
Time frame of a bit (Figure 24)		t_6		1060			1044			$512 \times T_{CLK}$		μs
Programming pulse (Figure 21, Figure 24)		t_7	133		529	131		521	$64 \times T_{CLK}$		$256 \times T_{CLK}$	μs

Electrical Characteristics (Continued)

All parameters refer to GND, $T_{amb} = -40^{\circ}\text{C}$ to $+105^{\circ}\text{C}$, $V_S = 4.5\text{ V}$ to 5.5 V , $f_0 = 433.92\text{ MHz}$ and $f_0 = 315\text{ MHz}$, unless otherwise specified. ($V_S = 5\text{ V}$, $T_{amb} = 25^{\circ}\text{C}$)

Parameter	Test Condition	Symbol	6.76438 Mhz Oscillator (Mode 1)			4.90625 Mhz Oscillator (Mode 0)			Variable Oscillator			Unit
			Min.	Typ.	Max.	Min.	Typ.	Max.	Min.	Typ.	Max.	
Equivalent acknowledge pulse: E_Ack (Figure 24)		t_8		265			261			$128 \times T_{Clk}$		μs
Equivalent time window (Figure 24)		t_9		534			526			$258 \times T_{Clk}$		μs
OFF-bit programming window (Figure 21)		t_{10}		930			916			$449.5 \times T_{Clk}$		μs

Electrical Characteristics

All parameters refer to GND, $T_{amb} = -40^{\circ}\text{C}$ to $+105^{\circ}\text{C}$, $V_S = 4.5\text{ V}$ to 5.5 V , $f_0 = 433.92\text{ MHz}$ and $f_0 = 315\text{ MHz}$, unless otherwise specified. ($V_S = 5\text{ V}$, $T_{amb} = 25^{\circ}\text{C}$)

Parameters	Test Conditions	Symbol	Min.	Typ.	Max.	Unit
Current consumption	Sleep mode (XTO and polling logic active)	$I_{S_{off}}$		190	350	μA
	IC active (startup-, bit check-, receiving mode) pin DATA = H	$I_{S_{on}}$		7.0	8.6	mA
LNA Mixer						
Third-order intercept point	LNA/mixer/IF amplifier input matched according to Figure 6	IIP3		-28		dBm
LO spurious emission at RF_{in}	Input matched according to Figure 6, required according to I-ETS 300220	$I_{S_{LORF}}$		-73	-57	dBm
Noise figure LNA and mixer (DSB)	Input matching according to Figure 6	NF		7		dB
LNA_IN input impedance	at 433.92 MHz at 315 MHz	$Z_{i_{LNA_IN}}$		$1.0 \parallel 1.56$ $1.3 \parallel 1.0$		$k\Omega \parallel pF$ $k\Omega \parallel pF$
1 dB compression point (LNA, mixer, IF amplifier)	Input matched according to Figure 6, referred to RF_{in}	IP_{1db}		-40		dBm
Maximum input level	Input matched according to Figure 6, BER $\leq 10^{-3}$, ASK mode	P_{in_max}			-28	dBm
					-20	dBm
Local Oscillator						
Operating frequency range VCO		f_{VCO}	299		449	MHz
Phase noise VCO/LO	$f_{osc} = 432.92\text{ MHz}$ at 1 MHz at 10 MHz	L (fm)		-93	-90	dBc/Hz
				-113	-110	dBc/Hz
Spurious of the VCO	at $\pm f_{XTO}$			-55	-47	dBc
VCO gain		K_{VCO}		190		MHz/V

Electrical Characteristics (Continued)

All parameters refer to GND, $T_{amb} = -40^{\circ}\text{C}$ to $+105^{\circ}\text{C}$, $V_S = 4.5\text{ V}$ to 5.5 V , $f_0 = 433.92\text{ MHz}$ and $f_0 = 315\text{ MHz}$, unless otherwise specified. ($V_S = 5\text{ V}$, $T_{amb} = 25^{\circ}\text{C}$)

Parameters	Test Conditions	Symbol	Min.	Typ.	Max.	Unit
Loop bandwidth of the PLL	For best LO noise (design parameter) $R_1 = 820\ \Omega$ $C_9 = 4.7\text{ nF}$ $C_{10} = 1\text{ nF}$	B_{Loop}		100		kHz
Capacitive load at pin LF	The capacitive load at pin LF is limited if bit check is used. The limitation therefore also applies to self-polling.	C_{LF_tot}			10	nF
XTO operating frequency	XTO crystal frequency, appropriate load capacitance must be connected to XTAL 6.764375 MHz 4.90625 MHz	f_{XTO}	6.764375	6.764375	6.764375	MHz
			-30 ppm 4.90625 -30 ppm	4.90625	4.90625	+30 ppm +30 ppm
Series resonance resistor of the crystal	$f_{XTO} = 6.764\text{ MHz}$ 4.906 MHz	R_S			150 220	Ω Ω
Static capacitance of the crystal		C_{xto}			6.5	pF
Analog Signal Processing						
Input sensitivity ASK	Input matched according to Figure 6 ASK (level of carrier) $BER \leq 10^{-3}$, $f_{IF} = 1\text{ MHz}$ $f_{in} = 433.92\text{ MHz}/315\text{ MHz}$ $T = 25^{\circ}\text{C}$, $V_S = 5\text{ V}$	P_{Ref_ASK}				
Input sensitivity ASK	BR_Range0		-108	-110	-112	dBm
	BR_Range1		-106.5	-108.5	-110.5	dBm
	BR_Range2		-106	-108	-110	dBm
	BR_Range3		-104	-106	-108	dBm
Sensitivity variation ASK for the full operating range compared to $T_{amb} = 25^{\circ}\text{C}$, $V_S = 5\text{ V}$	$f_{in} = 433.92\text{ MHz}/315\text{ MHz}$ $f_{IF} = 1\text{ MHz}$ $P_{ASK} = P_{Ref_ASK} + \Delta P_{Ref}$	ΔP_{Ref}	+2.5		-1.5	dB
Sensitivity variation ASK for full operating range including IF filter compared to $T_{amb} = 25^{\circ}\text{C}$, $V_S = 5\text{ V}$	$f_{in} = 433.92\text{ MHz}/315\text{ MHz}$ $f_{IF} = 0.79\text{ MHz}$ to 1.21 MHz $f_{IF} = 0.73\text{ MHz}$ to 1.27 MHz $P_{ASK} = P_{Ref_ASK} + \Delta P_{Ref}$	ΔP_{Ref}	+5.5		-1.5	dB
			+7.5		-1.5	dB
Input sensitivity FSK	Input matched according to Figure 6, $BER \leq 10^{-3}$, $f_{IF} = 1\text{ MHz}$ $f_{in} = 433.92\text{ MHz}/315\text{ MHz}$ $T = 25^{\circ}\text{C}$, $V_S = 5\text{ V}$	P_{Ref_FSK}				
Input sensitivity FSK	BR_Range0 $df \geq \pm 20\text{ kHz}$ $df \geq \pm 30\text{ kHz}$		-95.5	-97.5	-99.5	dBm
			-96.5	-98.5	-100.5	dBm
	BR_Range1 $df \geq \pm 20\text{ kHz}$ $df \geq \pm 30\text{ kHz}$		-94.5	-96.5	-98.5	dBm
			-95.5	-97.5	-99.5	dBm

Electrical Characteristics (Continued)

All parameters refer to GND, $T_{amb} = -40^{\circ}\text{C}$ to $+105^{\circ}\text{C}$, $V_S = 4.5\text{ V}$ to 5.5 V , $f_0 = 433.92\text{ MHz}$ and $f_0 = 315\text{ MHz}$, unless otherwise specified. ($V_S = 5\text{ V}$, $T_{amb} = 25^{\circ}\text{C}$)

Parameters	Test Conditions	Symbol	Min.	Typ.	Max.	Unit
Sensitivity variation FSK for the full operating range compared to $T_{amb} = 25^{\circ}\text{C}$, $V_S = 5\text{ V}$	$f_{in} = 433.92\text{ MHz}/315\text{ MHz}$ $f_{IF} = 1\text{ MHz}$ $P_{FSK} = P_{Ref_FSK} + \Delta P_{Ref}$	ΔP_{Ref}	+2.5		-1.5	dB
Sensitivity variation FSK for full operating range including IF filter compared to $T_{amb} = 25^{\circ}\text{C}$, $V_S = 5\text{ V}$	$f_{in} = 433.92\text{ MHz}/315\text{ MHz}$ $f_{IF} = 0.86\text{ MHz}$ to 1.14 MHz $f_{IF} = 0.82\text{ MHz}$ to 1.18 MHz $P_{FSK} = P_{Ref_FSK} + \Delta P_{Ref}$	ΔP_{Ref}	+5.5 +7.5		-1.5 -1.5	dB dB
FSK frequency deviation	The sensitivity of the receiver is higher for higher values of Δf_{FSK} BR_Range0 BR_Range1 BR_Range2 and BR_Range3 are not suitable for FSK operation	Δf_{FSK}	20 20	30 30	50 50	kHz kHz
S/N ratio to suppress inband noise signals	ASK mode FSK mode	SNR_{ASK} SNR_{FSK}	10 2		12 3	dB dB
Dynamic range RSSI amplifier		ΔR_{RSSI}		60		dB
Lower cut-off frequency of the data filter	$f_{cu_DF} = \frac{1}{2 \times \pi \times 30\text{ k}\Omega \times \text{CDEM}}$	f_{cu_DF}	0.11	0.16	0.20	kHz
Recommended CDEM for best performance	ASK mode BR_Range0 (Default) BR_Range1 BR_Range2 BR_Range3	CDEM		39 22 12 8.2		nF nF nF nF
Recommended CDEM for best performance	FSK mode BR_Range0 (Default) BR_Range1 BR_Range2 and BR_Range3 are not suitable for FSK operation	CDEM		27 15		nF nF
Maximum edge-to-edge time period of the input data signal for full sensitivity	BR_Range0 (Default) BR_Range1 BR_Range2 BR_Range3	t_{ee_sig}			1000 560 320 180	μs μs μs μs
Upper cut-off frequency data filter	Upper cut-off frequency programmable in 4 ranges via a serial mode word BR_Range0 (Default) BR_Range1 BR_Range2 BR_Range3	f_u	2.5 4.3 7.6 13.6	3.1 5.4 9.5 17.0	3.7 6.5 11.4 20.4	kHz kHz kHz kHz
Minimum edge-to-edge time period of the input data signal for full sensitivity	BR_Range0 (Default) BR_Range1 BR_Range2 BR_Range3	t_{ee_sig}			270 156 89 50	μs μs μs μs
Reduced sensitivity	R_{Sense} connected from pin Sens to V_S , input matched according to Figure 6	P_{Ref_Red}				dBm (peak level)

Electrical Characteristics (Continued)

All parameters refer to GND, $T_{amb} = -40^{\circ}\text{C}$ to $+105^{\circ}\text{C}$, $V_S = 4.5\text{ V}$ to 5.5 V , $f_0 = 433.92\text{ MHz}$ and $f_0 = 315\text{ MHz}$, unless otherwise specified. ($V_S = 5\text{ V}$, $T_{amb} = 25^{\circ}\text{C}$)

Parameters	Test Conditions	Symbol	Min.	Typ.	Max.	Unit
Reduced sensitivity	($V_S = 5\text{ V}$, $T_{amb} = 25^{\circ}\text{C}$) $R_{Sense} = 56\text{ k}\Omega$, $f_{in} = 433.92\text{ MHz}$,		-67	-72	-77	dBm
	$R_{Sense} = 100\text{ k}\Omega$, $f_{in} = 433.92\text{ MHz}$		-76	-81	-86	dBm
	$R_{Sense} = 56\text{ k}\Omega$, $f_{in} = 315\text{ MHz}$		-68	-73	-78	dBm
	$R_{Sense} = 100\text{ k}\Omega$, $f_{in} = 315\text{ MHz}$		-77	-82	-87	dBm
Reduced sensitivity variation over full operating range	$R_{Sense} = 56\text{ k}\Omega$	ΔP_{Red}	5	0	0	dB
	$R_{Sense} = 100\text{ k}\Omega$ $P_{Red} = P_{Ref_Red} + \Delta P_{Red}$		6	0	0	dB
Reduced sensitivity variation for different values of R_{Sense}	Values relative to $R_{Sense} = 56\text{ k}\Omega$	ΔP_{Red}				
	$R_{Sense} = 56\text{ k}\Omega$			0		dB
	$R_{Sense} = 68\text{ k}\Omega$			-3.5		dB
	$R_{Sense} = 82\text{ k}\Omega$			-6.0		dB
	$R_{Sense} = 100\text{ k}\Omega$			-9.0		dB
	$R_{Sense} = 120\text{ k}\Omega$			-11.0		dB
	$R_{Sense} = 150\text{ k}\Omega$ $P_{Red} = P_{Ref_Red} + \Delta P_{Red}$			-13.5		dB
Threshold voltage for reset		$V_{ThRESET}$	1.95	2.8	3.75	V
Digital Ports						
Data output - Saturation voltage LOW - Internal pull-up resistor - Maximum time constant - Maximum capacitive load	$I_{ol} = 1\text{ mA}$ $\tau = C_L (R_{pup} // R_{Ext})$ without external pull-up resistor $R_{ext} = 5\text{ k}\Omega$	V_{Ol} R_{Pup} τ C_L C_L	39	0.08 50	0.3 61 2.5 41 540	V k Ω μs pF pF
FSK/ASK input - Low-level input voltage - High-level input voltage	FSK selected ASK selected	V_{ll} V_{lh}	$0.8 \times V_S$		$0.2 \times V_S$	V V
ENABLE input - Low-level input voltage - High-level input voltage	Idle mode Active mode	V_{ll} V_{lh}	$0.8 \times V_S$		$0.2 \times V_S$	V V
MODE input - Low-level input voltage - High-level input voltage	Division factor = 10 Division factor = 14	V_{ll} V_{lh}	$0.8 \times V_S$		$0.2 \times V_S$	V V
TEST input - Low-level input voltage	Test input must always be set to LOW	V_{ll}			$0.2 \times V_S$	V

Ordering Information

Extended Type Number	Package	Remarks
U3742BM-M3FL	SO20	Tube
U3742BM-M3FLG3	SO20	Taped and reeled

Package Information

Package SO20

Dimensions in mm

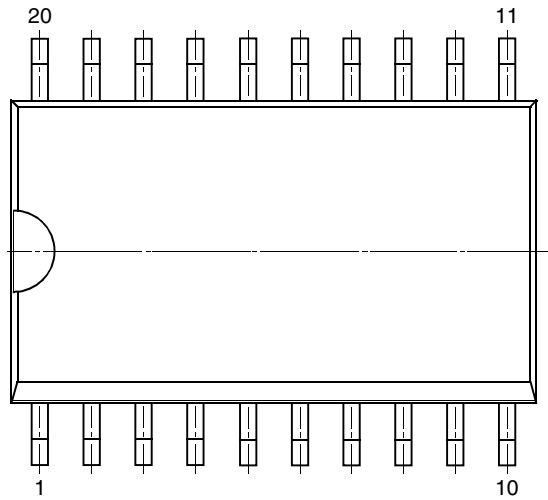
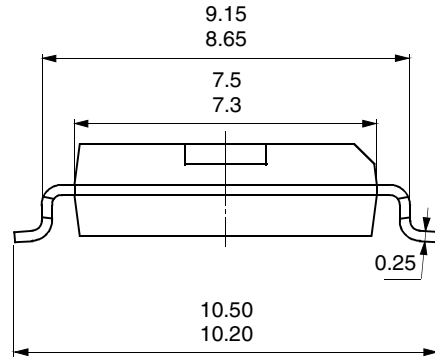
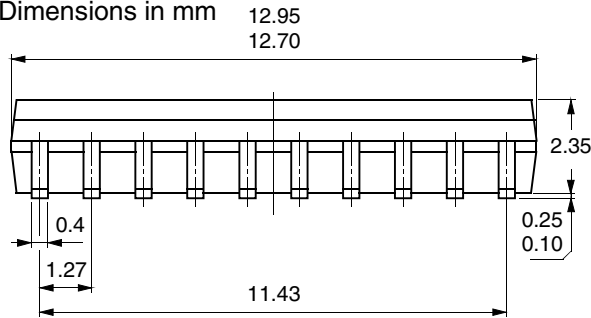

 technical drawings
 according to DIN
 specifications



Atmel Corporation

2325 Orchard Parkway
San Jose, CA 95131, USA
Tel: 1(408) 441-0311
Fax: 1(408) 487-2600

Regional Headquarters

Europe

Atmel Sarl
Route des Arsenalux 41
Case Postale 80
CH-1705 Fribourg
Switzerland
Tel: (41) 26-426-5555
Fax: (41) 26-426-5500

Asia

Room 1219
Chinachem Golden Plaza
77 Mody Road Tsimshatsui
East Kowloon
Hong Kong
Tel: (852) 2721-9778
Fax: (852) 2722-1369

Japan

9F, Tonetsu Shinkawa Bldg.
1-24-8 Shinkawa
Chuo-ku, Tokyo 104-0033
Japan
Tel: (81) 3-3523-3551
Fax: (81) 3-3523-7581

Atmel Operations

Memory

2325 Orchard Parkway
San Jose, CA 95131, USA
Tel: 1(408) 441-0311
Fax: 1(408) 436-4314

Microcontrollers

2325 Orchard Parkway
San Jose, CA 95131, USA
Tel: 1(408) 441-0311
Fax: 1(408) 436-4314

La Chantrerie
BP 70602
44306 Nantes Cedex 3, France
Tel: (33) 2-40-18-18-18
Fax: (33) 2-40-18-19-60

ASIC/ASSP/Smart Cards

Zone Industrielle
13106 Rousset Cedex, France
Tel: (33) 4-42-53-60-00
Fax: (33) 4-42-53-60-01

1150 East Cheyenne Mtn. Blvd.
Colorado Springs, CO 80906, USA
Tel: 1(719) 576-3300
Fax: 1(719) 540-1759

Scottish Enterprise Technology Park
Maxwell Building
East Kilbride G75 0QR, Scotland
Tel: (44) 1355-803-000
Fax: (44) 1355-242-743

RF/Automotive

Theresienstrasse 2
Postfach 3535
74025 Heilbronn, Germany
Tel: (49) 71-31-67-0
Fax: (49) 71-31-67-2340

1150 East Cheyenne Mtn. Blvd.
Colorado Springs, CO 80906, USA
Tel: 1(719) 576-3300
Fax: 1(719) 540-1759

Biometrics/Imaging/Hi-Rel MPU/ High Speed Converters/RF Datacom

Avenue de Rochepleine
BP 123
38521 Saint-Egreve Cedex, France
Tel: (33) 4-76-58-30-00
Fax: (33) 4-76-58-34-80

Literature Requests

www.atmel.com/literature

Disclaimer: Atmel Corporation makes no warranty for the use of its products, other than those expressly contained in the Company's standard warranty which is detailed in Atmel's Terms and Conditions located on the Company's web site. The Company assumes no responsibility for any errors which may appear in this document, reserves the right to change devices or specifications detailed herein at any time without notice, and does not make any commitment to update the information contained herein. No licenses to patents or other intellectual property of Atmel are granted by the Company in connection with the sale of Atmel products, expressly or by implication. Atmel's products are not authorized for use as critical components in life support devices or systems.

© Atmel Corporation 2003. All rights reserved.

Atmel® and combinations thereof are the registered trademarks of Atmel Corporation or its subsidiaries.

Other terms and product names may be the trademarks of others.



Printed on recycled paper.