



12N70

Power MOSFET

12 Amps, 700 Volts N-CHANNEL MOSFET

DESCRIPTION

The UTC **12N70** are N-Channel enhancement mode power field effect transistors (MOSFET) which are produced using UTC's proprietary, planar stripe, DMOS technology.

These devices are suited for high efficiency switch mode power supply. To minimize on-state resistance, provide superior switching performance, and withstand high energy pulse in the avalanche and commutation mode the advanced technology has been especially tailored.

FEATURES

- * $R_{DS(ON)} = 0.87\Omega @ V_{GS} = 10V$
- * Ultra low gate charge (typical 42 nC)
- * Low reverse transfer capacitance ($C_{RSS} =$ typical 25 pF)
- * Fast switching capability
- * Avalanche energy specified
- * Improved dv/dt capability, high ruggedness

SYMBOL

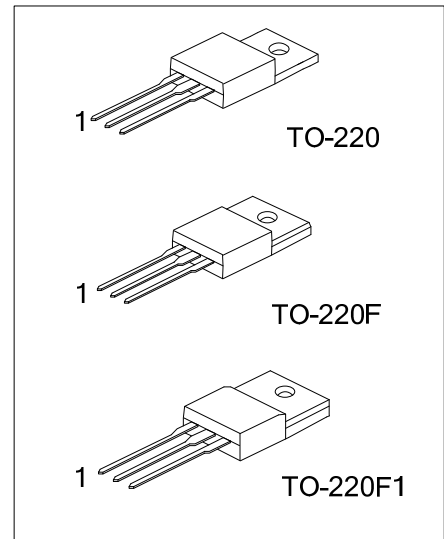
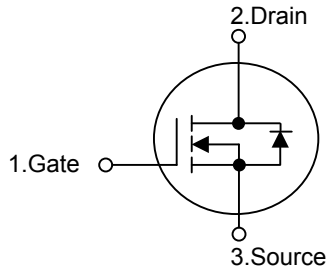

ORDERING INFORMATION

Ordering Number		Package	Pin Assignment			Packing
Lead Free Plating	Halogen Free		1	2	3	
12N70L-TA3-T	12N70G-TA3-T	TO-220	G	D	S	Tube
12N70L-TF1-T	12N70G-TF1-T	TO-220F1	G	D	S	Tube
12N70L-TF3-T	12N70G-TF3-T	TO-220F	G	D	S	Tube

Note: Pin Assignment: G: Gate D: Drain S: Source

<p>12N70L-TA3-T</p> <p>(1)Packing Type</p> <p>(2)Package Type</p> <p>(3)Lead Plating</p>	<p>(1) T: Tube</p> <p>(2) TA3: TO-220, TF1: TO220-F1, TF3: TO-220F</p> <p>(3) G: Halogen Free, L: Lead Free</p>
--	---

■ ABSOLUTE MAXIMUM RATINGS ($T_C = 25^\circ\text{C}$, unless otherwise specified)

PARAMETER		SYMBOL	RATINGS	UNIT
Drain-Source Voltage		V_{DSS}	700	V
Gate-Source Voltage		V_{GSS}	± 30	V
Avalanche Current (Note 2)		I_{AR}	12	A
Drain Current	Continuous	I_D	12	A
	Pulsed (Note 2)	I_{DM}	48	A
Avalanche Energy	Single Pulsed (Note 3)	E_{AS}	790	mJ
	Repetitive (Note 2)	E_{AR}	24	mJ
Peak Diode Recovery dv/dt (Note 4)		dv/dt	4.5	V/ns
Power Dissipation	TO-220	P_D	225	$^\circ\text{C/W}$
	TO-220F/TO-220F1		51	$^\circ\text{C/W}$
Junction Temperature		T_J	+150	$^\circ\text{C}$
Operating Temperature		T_{OPR}	-55 ~ +150	$^\circ\text{C}$
Storage Temperature		T_{STG}	-55 ~ +150	$^\circ\text{C}$

Notes: 1. Absolute maximum ratings are those values beyond which the device could be permanently damaged.

Absolute maximum ratings are stress ratings only and functional device operation is not implied.

2. Repetitive Rating : Pulse width limited by maximum junction temperature

3. $L = 10\text{mH}$, $I_{AS} = 12\text{A}$, $V_{DD} = 50\text{V}$, $R_G = 25\Omega$, Starting $T_J = 25^\circ\text{C}$

4. $I_{SD} \leq 12\text{A}$, $di/dt \leq 200\text{A/s}$, $V_{DD} \leq BV_{DSS}$ Starting $T_J = 25^\circ\text{C}$

■ THERMAL DATA

PARAMETER		SYMBOL	RATING	UNIT
Junction to Ambient		θ_{JA}	62.5	$^\circ\text{C/W}$
Junction to Case	TO-220	θ_{JC}	0.56	$^\circ\text{C/W}$
	TO-220F/TO-220F1		2.43	$^\circ\text{C/W}$

■ ELECTRICAL CHARACTERISTICS ($T_C = 25^\circ\text{C}$, unless otherwise specified)

PARAMETER	SYMBOL	TEST CONDITIONS	MIN	TYP	MAX	UNIT
OFF CHARACTERISTICS						
Drain-Source Breakdown Voltage	BV_{DSS}	$V_{GS} = 0\text{V}$, $I_D = 250\mu\text{A}$	700			V
Drain-Source Leakage Current	I_{DSS}	$V_{DS} = 700\text{V}$, $V_{GS} = 0\text{V}$			10	μA
Gate-Source Leakage Current	I_{GSS}	$V_{GS} = \pm 30\text{V}$, $V_{DS} = 0\text{V}$			± 100	nA
Breakdown Voltage Temperature Coefficient	$\Delta BV_{DSS}/\Delta T_J$	$I_D = 250\mu\text{A}$, Referenced to 25°C		0.7		$\text{V}/^\circ\text{C}$
ON CHARACTERISTICS						
Gate Threshold Voltage	$V_{GS(TH)}$	$V_{DS} = V_{GS}$, $I_D = 250\mu\text{A}$	2.0		4.0	V
Static Drain-Source On-State Resistance	$R_{DS(ON)}$	$V_{GS} = 10\text{V}$, $I_D = 6.0\text{A}$		0.87	1.0	Ω
DYNAMIC CHARACTERISTICS						
Input Capacitance	C_{ISS}	$V_{DS} = 25\text{V}$, $V_{GS} = 0\text{V}$, $f = 1\text{MHz}$		1480	1900	pF
Output Capacitance	C_{OSS}			200	270	pF
Reverse Transfer Capacitance	C_{RSS}			25	35	pF
SWITCHING CHARACTERISTICS						
Turn-On Delay Time	$t_{D(ON)}$	$V_{DD} = 300\text{V}$, $I_D = 12\text{A}$, $R_G = 25\Omega$ (Note 1, 2)		30	70	ns
Turn-On Rise Time	t_R			115	240	ns
Turn-Off Delay Time	$t_{D(OFF)}$			95	200	ns
Turn-Off Fall Time	t_F			85	180	ns
Total Gate Charge	Q_G			42	54	nC
Gate-Source Charge	Q_{GS}	$V_{DS} = 480\text{V}$, $I_D = 12\text{A}$, $V_{GS} = 10\text{V}$ (Note 1, 2)		8.6		nC
Gate-Drain Charge	Q_{GD}			21		nC

■ ELECTRICAL CHARACTERISTICS(Cont.)

PARAMETER	SYMBOL	TEST CONDITIONS	MIN	TYP	MAX	UNIT
SOURCE- DRAIN DIODE RATINGS AND CHARACTERISTICS						
Drain-Source Diode Forward Voltage	V_{SD}	$V_{GS} = 0\text{ V}, I_S = 12\text{ A}$			1.4	V
Maximum Continuous Drain-Source Diode Forward Current	I_S				12	A
Maximum Pulsed Drain-Source Diode Forward Current	I_{SM}				48	A
Reverse Recovery Time	t_{RR}	$V_{GS} = 0\text{ V}, I_S = 12\text{ A},$		380		ns
Reverse Recovery Charge	Q_{RR}	$di_F/dt = 100\text{ A}/\mu\text{s}$ (Note 1)		3.5		μC

Notes: 1. Pulse Test : Pulse width $\leq 300\mu\text{s}$, Duty cycle $\leq 2\%$

2. Essentially independent of operating temperature.

■ TEST CIRCUITS AND WAVEFORMS

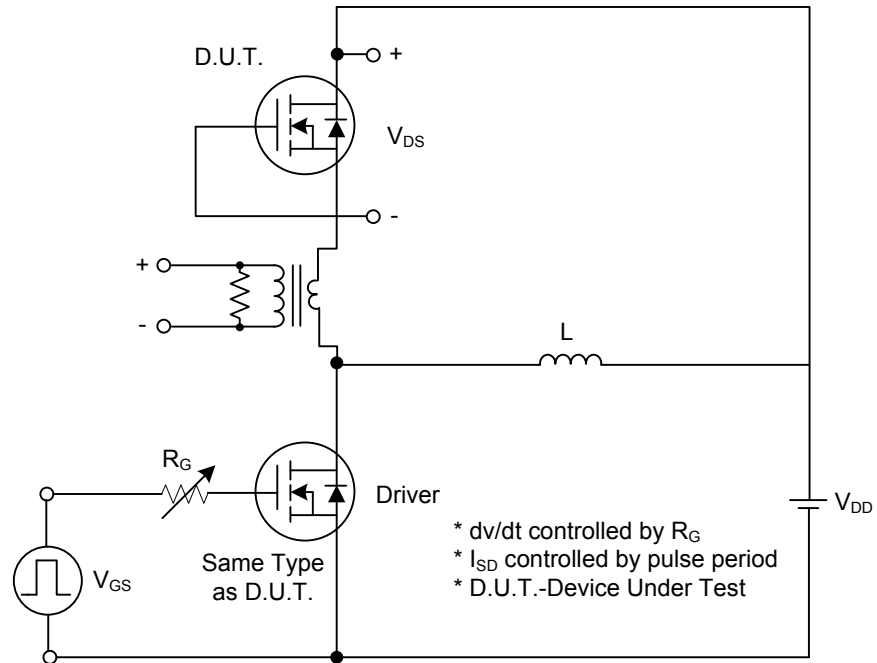

Fig. 1A Peak Diode Recovery dv/dt Test Circuit

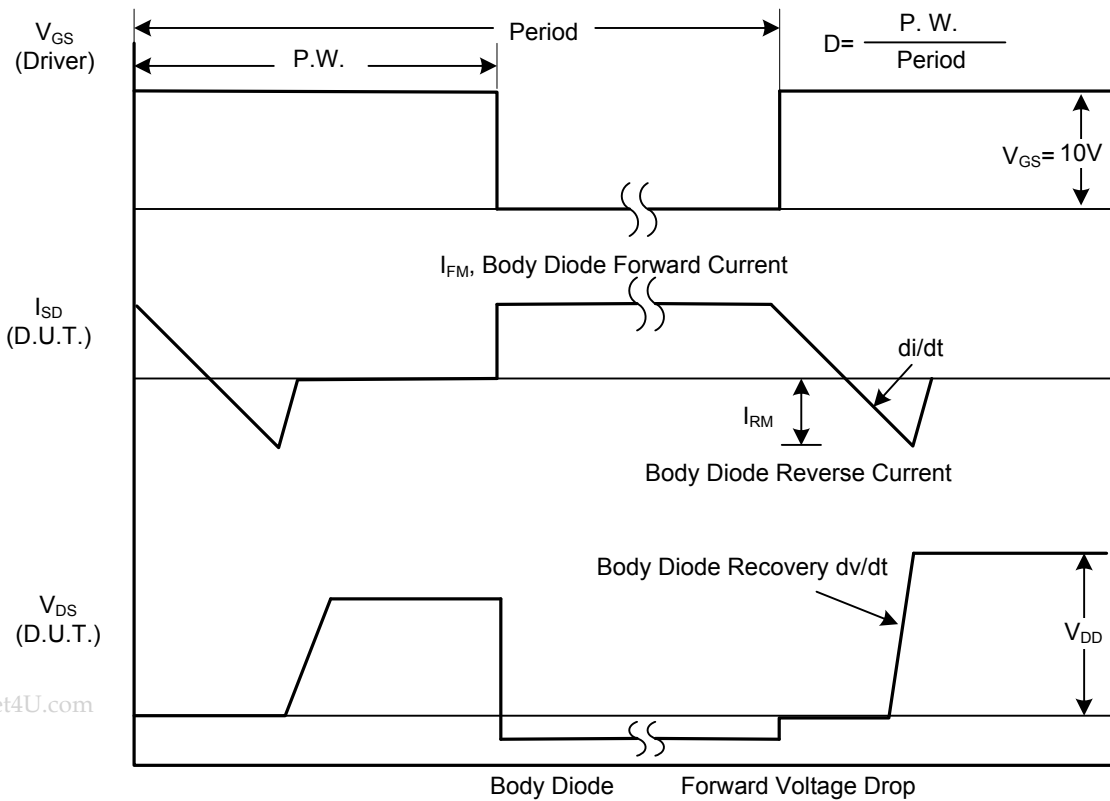

Fig. 1B Peak Diode Recovery dv/dt Waveforms

www.DataSheet4U.com

TEST CIRCUITS AND WAVEFORMS (Cont.)

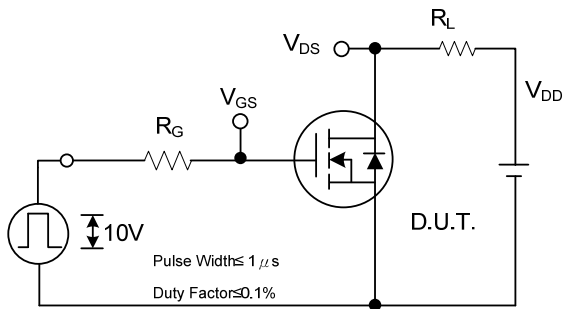

Fig. 2A Switching Test Circuit

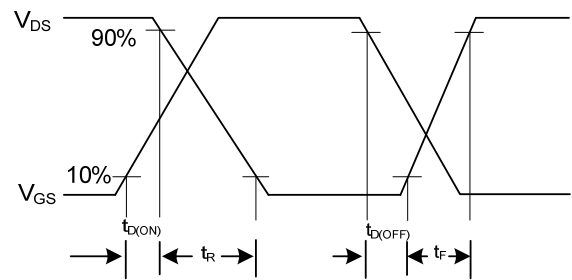

Fig. 2B Switching Waveforms

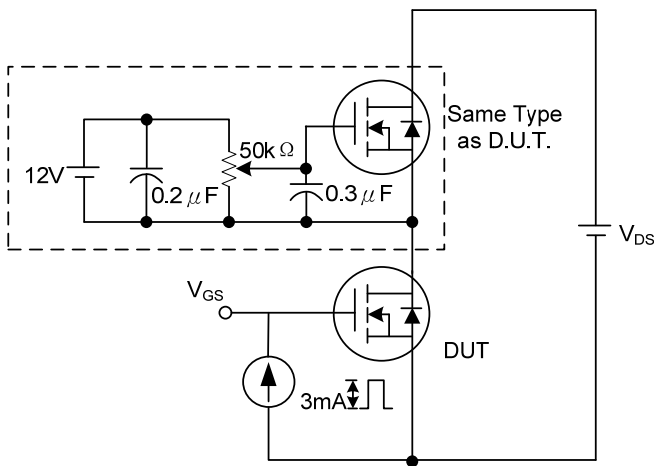

Fig. 3A Gate Charge Test Circuit

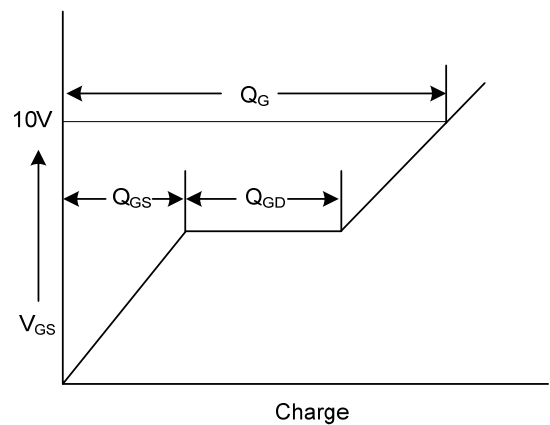

Fig. 3B Gate Charge Waveform

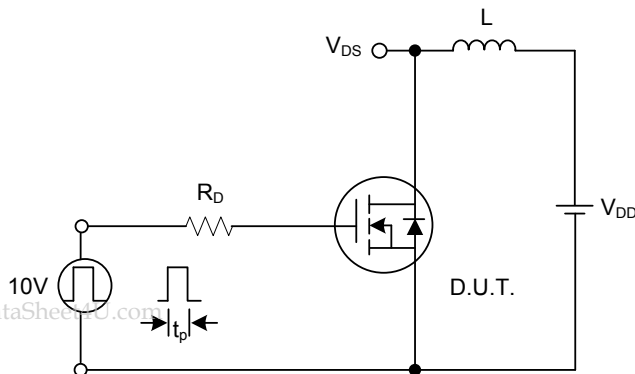

Fig. 4A Unclamped Inductive Switching Test Circuit

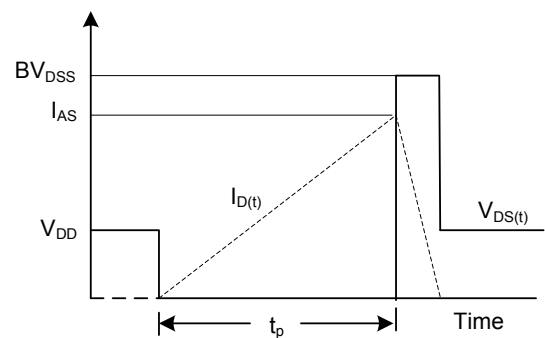
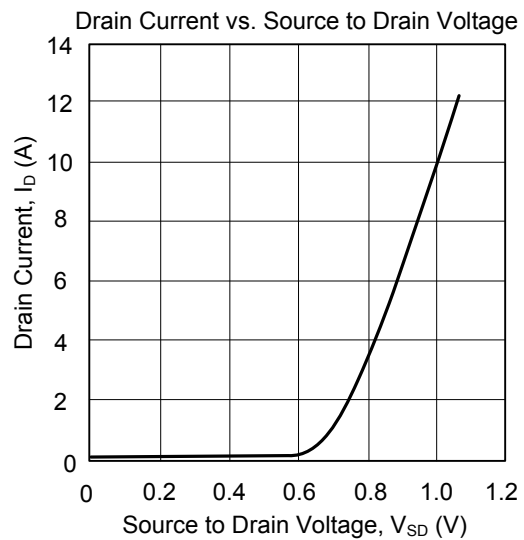
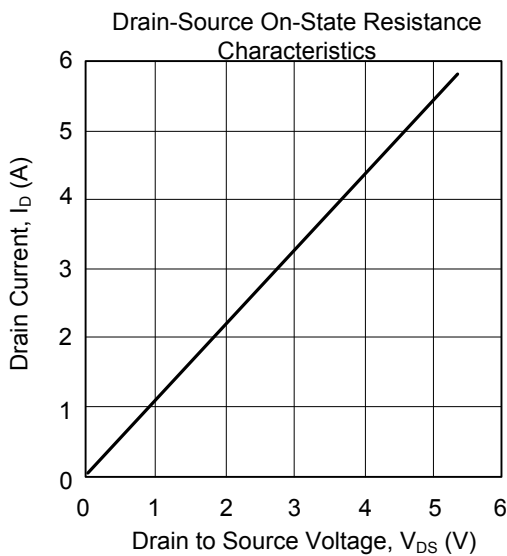
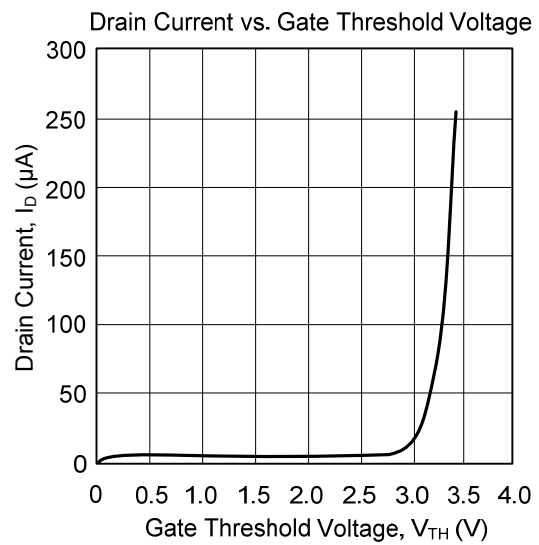
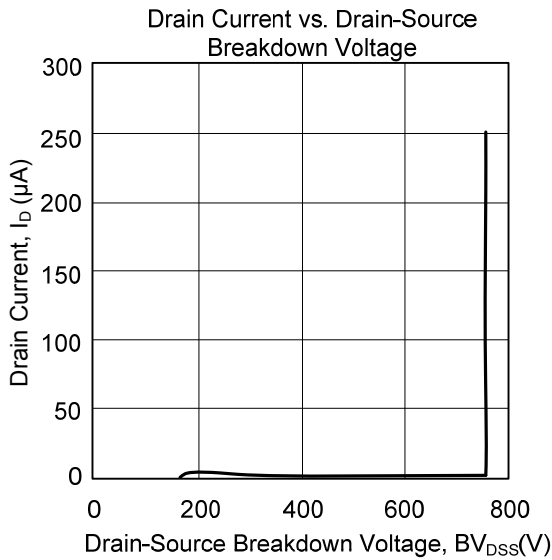

Fig. 4B Unclamped Inductive Switching Waveforms

TYPICAL CHARACTERISTICS



UTC assumes no responsibility for equipment failures that result from using products at values that exceed, even momentarily, rated values (such as maximum ratings, operating condition ranges, or other parameters) listed in products specifications of any and all UTC products described or contained herein. UTC products are not designed for use in life support appliances, devices or systems where malfunction of these products can be reasonably expected to result in personal injury. Reproduction in whole or in part is prohibited without the prior written consent of the copyright owner. The information presented in this document does not form part of any quotation or contract, is believed to be accurate and reliable and may be changed without notice.