

PLEASE CHECK WWW.MOLEX.COM FOR LATEST PART INFORMATION

Part Number: **0196060005**
Status: **Active**
Description: Avikrimp™ Fully Insulated Quick Disconnect, Female, for 10-12 AWG Wire, Box

Documents:

[Drawing \(PDF\)](#) [RoHS Certificate of Compliance \(PDF\)](#)

Agency Certification

CSA LR18689
 UL E79133

General

Product Family Quick Disconnects
 Series 19606
 Crimp Quality Equipment Yes
 Product Name Avikrimp™
 Type Quick Disconnect

Physical

Barrel Type Closed
 Flammability 94V-2
 Gender Female
 Glow-Wire Compliant No
 Insulation Nylon (PA)
 Lock to Mating Part None
 Material - Metal Brass
 Material - Plating Mating Tin
 Material - Plating Termination Tin
 Orientation Straight
 Packaging Type Bag
 Plating min: Mating (µin) 100
 Plating min: Mating (µm) 2.5
 Plating min: Termination (µin) 100
 Plating min: Termination (µm) 2.5
 Polarized to Mating Part No
 Tab Thickness 0.81mm (.032")
 Tab Width 6.35mm (.250")
 Temperature Range - Operating -65°C to +105°C
 Termination Interface: Style Crimp or Compression
 Wire Insulation Diameter 5.84mm (.230") max.
 Wire Size AWG 10, 12
 Wire Size mm² 3.30 - 5.00

Electrical

Voltage - Maximum 300V

Material Info

Old Part Number C-5293

Reference - Drawing Numbers

Sales Drawing SD-19606-401

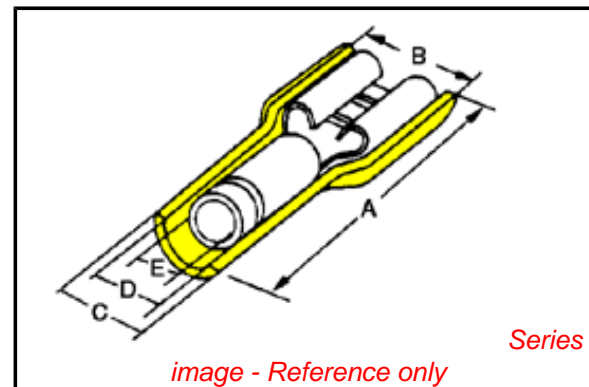

EU RoHS

ELV and RoHS Compliant
REACH SVHC
 Not Reviewed
Halogen-Free Status

China RoHS



Not Reviewed

Need more information on product environmental compliance?

Email productcompliance@molex.com
 For a multiple part number RoHS Certificate of Compliance, [click here](#)

Please visit the [Contact Us](#) section for any non-product compliance questions.

Search Parts in this Series

19606Series

Application Tooling | FAQ

Tooling specifications and manuals are found by selecting the products below. Crimp Height Specifications are then contained in the Application Tooling Specification document.

Global

Description	Product #
Hand Crimp Tool	0640010200
Crimp Head for the AT-200™ Pneumatic Hand Tool	0640050200

MATERIAL NO.	ENGINEERING P/N	CARRIER STYLE
196060004	C-5293Z	METAL STRIP
196060005	C-5293	LOOSE PIECE
196060006	C-5293T	TAPE MOUNT

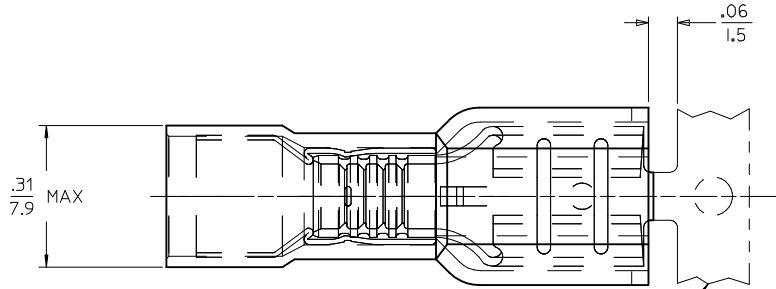

METAL CARRIER STRIP,
METAL STRIP PARTS ONLY

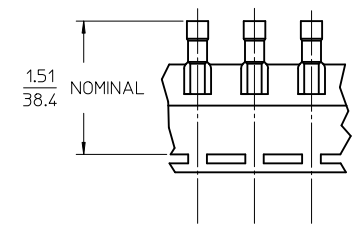

PARTS ON TAPE
SCALE: NONE

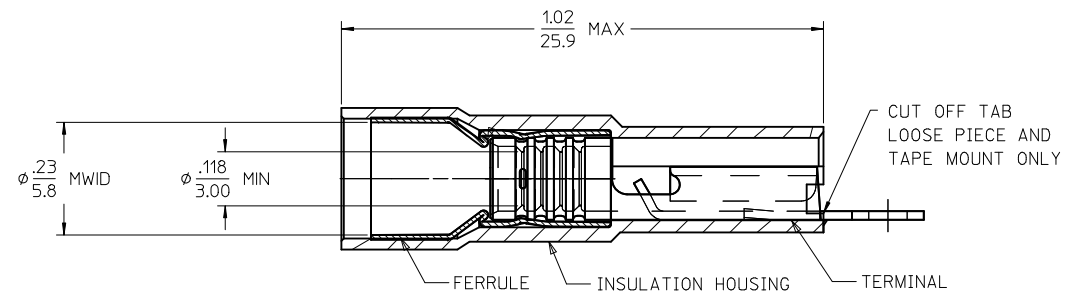

SECTION A-A

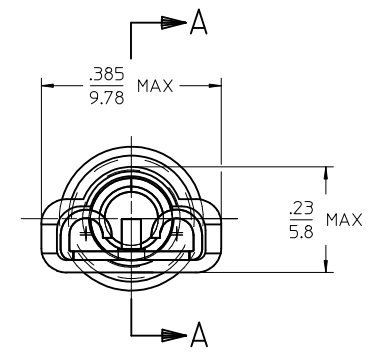

NOTES:

- MATERIALS:
HOUSING: 94V-2 NYLON, YELLOW
TERMINAL: BRASS, .018/0.46 THICK REF., MATTE TIN PLATED
FERRULE: COPPER ALLOY, MATTE TIN PLATED
- ACCEPTS TAB SIZE .250 x .032 (6.35 x 0.81).
- MWID = MAXIMUM WIRE INSULATION DIAMETER.
- PARTS ARE ROHS COMPLIANT.

REVISIONS RLS: FERRULE MATL EC NO: MNA2010-0610 DRW: ETHRODAHL 2010/03/31 CHKD: JMACNEIL 2010/03/31 APPR: JMACNEIL 2010/04/12	QUALITY SYMBOLS ▽=0 ▽=0	GENERAL TOLERANCES (UNLESS SPECIFIED)		DIMENSION STYLE IN/MM	SCALE 5:1	DESIGN UNITS INCH	THIRD ANGLE PROJECTION
		4 PLACES ± --- ± --- 3 PLACES ± --- ± --- 2 PLACES ± --- ± --- 1 PLACE ± --- ± --- ANGULAR ±1/2°	DRAWN BY: ETHRODAHL DATE: 2010/03/31 CHECKED BY: JMACNEIL DATE: 2010/03/31 APPROVED BY: JMACNEIL DATE: 2010/04/09	TITLE FIQD FEMALE AVIKRIMP LOW PROFILE .250X.032 TAB, 12-10 AWG			MOLEX INCORPORATED
DESCRIPTION A	DRAFT WHERE APPLICABLE MUST REMAIN WITHIN DIMENSIONS	SEE CHART		DOCUMENT NO. SD-19606-003		THIS DRAWING CONTAINS INFORMATION THAT IS PROPRIETARY TO MOLEX INCORPORATED AND SHOULD NOT BE USED WITHOUT WRITTEN PERMISSION	