

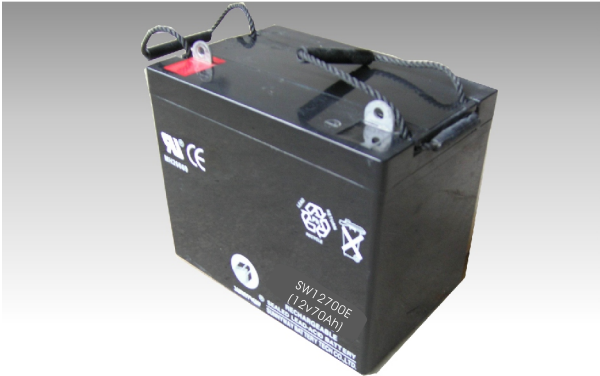

SHENZHEN SUNNYWAY BATTERY TECH CO.,LTD.

SW12700E(12V70AH)



● Specifications

Nominal Voltage		12V	
Rated capacity (10 hour rate)		70 Ah	
Dimensions	Total Height	T33	228 mm (8.98 inches)
		T16	216 mm (8.50 inches)
	Height	210 mm (8.27inches)	
	Length	260 mm (10.2 inches)	
Width		169 mm (6.65 inches)	
Weight Approx		23 Kg (50.66 lbs)	

● Characteristics

Capacity 25°C(77°F)	10 hour rate(7.0A)	70 AH
	5 hour rate(11.2 A)	56 AH
	1 hour rate(38.5A)	38.5 AH
Internal Resistance	Full charged Battery at 25°C(77°F)	6 mΩ
Capacity affected by Temperature (10hour rate)	40°C(104°F)	102%
	25°C(77°F)	100%
	0°C(32°F)	85%
	-15°C(5°F)	65%
Self-Discharge at 25°C(77°F)	Capacity after 3 month storage	91%
	Capacity after 6 month storage	82%
	Capacity after 12 month storage	64%
Terminal		T16 T33
Charge (constant Voltage)	Cycle	Initial Charging Current less than 17.5 A Voltage 14.10-14.40V
	Float	Voltage 13.50-13.80V

● Outer dimensions (mm)

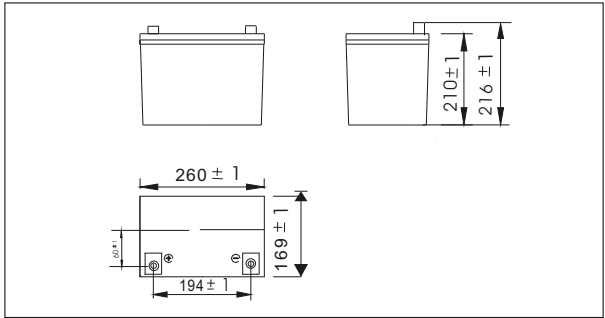

● Terminal Type (mm)

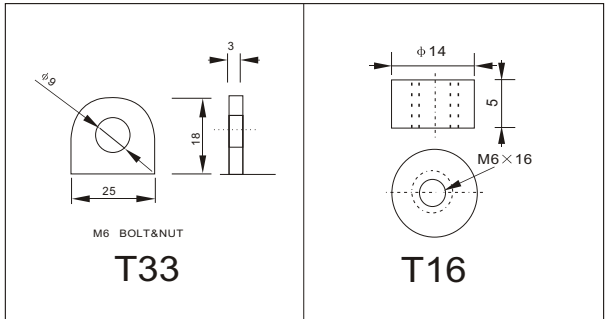

● Discharge Curves 25°C(77°F)

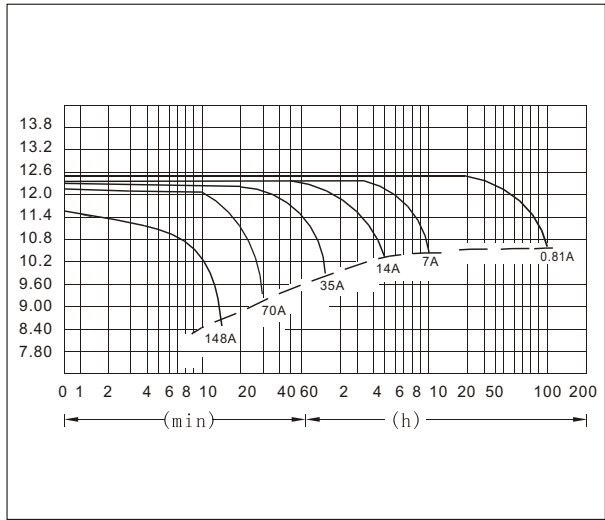

Constant Current(Amp) and Constant Power(Watt) Discharge Table at 25°C(77°F)												
Time		10min	30min	1h	3h	4h	5h	8h	10h	20h	50h	100h
9.60V	A	148	80	42	18.0	14.0	11.6	8.1	7.4	3.97	1.65	0.85
	W	1640	855	486	208	162	134	94	85	46.0	19.7	10.1
10.20V	A	144	78	39.5	17.5	13.7	11.3	8.0	7.2	3.87	1.60	0.83
	W	1577	847	457	203	158	131	92	83	44.8	19.0	9.8
10.50V	A	137	74	38	17.1	13.4	11.2	7.9	7.0	3.82	1.57	0.81
	W	1529	799	443	198	156	130	92	82	44.3	18.7	9.6
10.80V	A	128	71	37	16.7	13.2	10.9	7.7	6.8	3.78	1.54	0.80
	W	1469	769	423	194	152	127	90	81	44.0	18.3	9.5
11.10V	A	118	66	35	16.1	12.8	10.6	7.5	6.65	3.59	1.51	0.77
	W	1444	763	412	192	152	127	89	79	42.7	18.0	9.2