



M.S.KENNEDY CORP.

HIGH SPEED/VOLTAGE OP AMP

1461

4707 Dey Road Liverpool, N.Y. 13088

(315) 701-6751

FEATURES:

- Extremely Fast - 500v/ μ S
- Wide Supply Range $\pm 15V$ to $\pm 45V$
- VMOS Output, No S.O.A. Restrictions
- Large Gain-Bandwidth Product
- FET Input
- Electrically Isolated Case
- 800mA Typical Output Current

MIL-PRF-38534 CERTIFIED

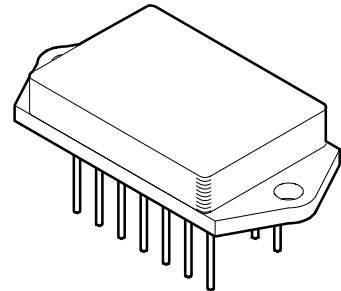

DESCRIPTION:

The MSK 1461 is a state of the art high speed FET input operational amplifier. The distinguishing characteristic of the MSK 1461 is its unique VMOS output stage which completely eliminates the safe operating area restrictions associated with secondary breakdown of bipolar transistor output stage op-amps. Freedom from secondary breakdown allows the 1461 to handle large output currents at any voltage level limited only by transistor junction temperature. 115 dB of open loop gain gives the 1461 high closed loop gain accuracy and the typical $\pm 1.0mV$ of input offset voltage will fit well in any error budget. A 500 V/ μ S slew rate and 1200 MHz gain bandwidth product make the 1461 an outstanding high-speed op-amp. A single external capacitor is used for compensation and output current limiting is user programmable through the selection of two external resistors.

EQUIVALENT SCHEMATIC

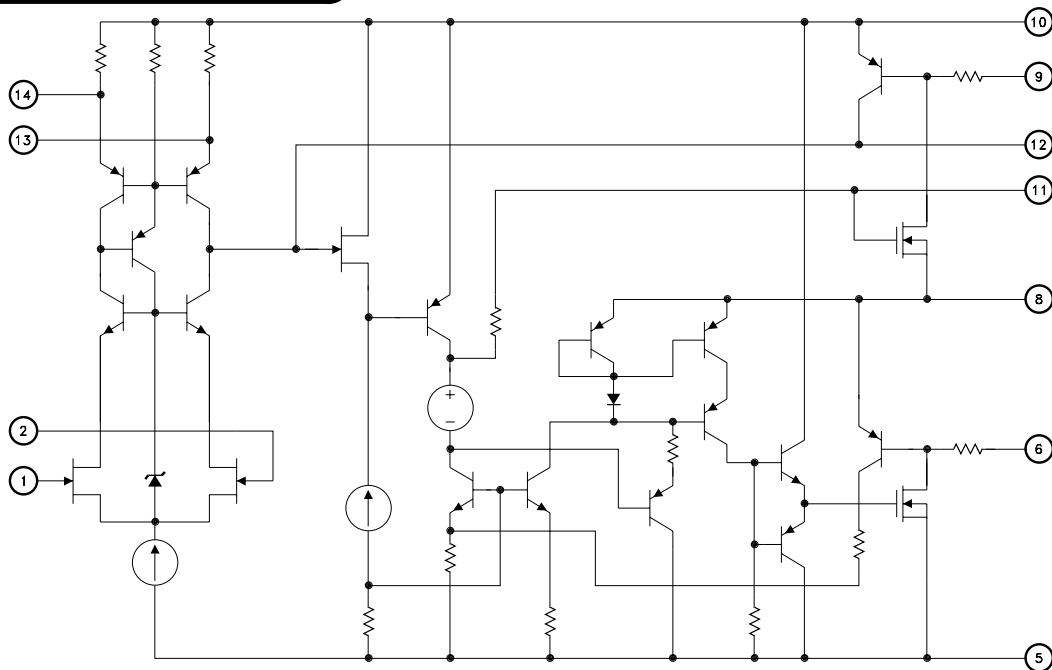

TYPICAL APPLICATIONS

- Video Yoke Drivers
- Video Distribution Amplifiers
- High Accuracy Audio Amplification
- High Speed ATE Pin Drivers

PIN-OUT INFORMATION

- | | |
|--------------------------|--------------------------|
| 1 Inverting Input | 8 Output |
| 2 Non-Inverting Input | 9 Positive Current Limit |
| 3 No Connection | 10 Positive Power Supply |
| 4 No Connection | 11 Compensation |
| 5 Negative Power Supply | 12 Compensation |
| 6 Negative Current Limit | 13 Offset Adjust |
| 7 No Connection | 14 Offset Adjust |

ABSOLUTE MAXIMUM RATINGS

$\pm V_{CC}$	Supply Voltage	$\pm 45V$
I_{OUT}	Output Current	800mA
V_{IN}	Differential Input Voltage	$\pm 25V$
R_{TH}	Thermal Resistance Junction to Case (Output Devices Only)	12°C/W

T_{ST}	Storage Temperature Range	-65°C to +150°C
T_{LD}	Lead Temperature Range (10 Seconds)	300°C
T_C	Case Operating Temperature (MSK 1461B)	-55°C to +125°C
	(MSK 1461)	-40°C to 85°C
T_J	Junction Temperature	+175°C

ELECTRICAL SPECIFICATIONS

Parameter	Test Conditions	Group A Subgroup	MSK 1461B			MSK 1461			Units
			Min.	Typ.	Max.	Min.	Typ.	Max.	
STATIC									
Supply Voltage Range ③		-	± 15	-	± 45	± 15	-	± 45	V
Quiescent Current	$V_{IN} = 0V$	1	-	± 19	± 25	-	± 19	± 28	mA
		2,3	-	± 21	± 35	-	-	-	mA
Thermal Resistance ③	Junction to Case	-	-	11	12	-	11	15	°C/W
INPUT									
Input Offset Voltage	$V_{IN} = 0V$ $A_V = -10V/V$	1	-	± 1.0	± 5.0	-	± 1.0	± 8.0	mV
Input Offset Voltage Drift	Bal. Pins = N/C	2,3	-	± 6.0	± 50	-	± 10	-	$\mu V/^\circ C$
Input Offset Adjust ③	$R_{POT} = 10K\Omega$ to $+V_{CC}$	-	-	± 8.0	-	-	± 8.0	-	V
Input Bias Current	$V_{CM} = 0V$ Either Input	1	-	± 10	± 300	-	± 10	± 300	pA
		2,3	-	± 10	± 100	-	-	-	nA
Input Offset Current ③	$V_{CM} = 0V$	-	-	± 5.0	-	-	± 5.0	-	pA
		-	-	± 5.0	-	-	-	-	nA
Input Impedance ③	F = DC	-	-	3×10^{12}	-	-	3×10^{12}	-	Ω
Common Mode Range ③		-	± 22	± 24	-	± 22	± 24	-	V
Common Mode Rejection Ratio ③	F = 10KHz $V_{CM} = \pm 22V$	4	90	100	-	90	100	-	dB
OUTPUT									
Output Voltage Swing	$R_L = 50\Omega$ $A_V = -5V/V$	4	± 27	± 31	-	± 27	± 31	-	V
	$R_L = 1K\Omega$	4	± 30	± 33	-	± 30	± 33	-	V
Output Current, Peak	$R_L = 33\Omega$ $A_V = -5V/V$ $T_J < 175^\circ C$	4	± 600	± 800	-	± 600	± 800	-	mA
Settling Time ② ③	0.1% 10V step	4	-	400	800	-	400	800	nS
TRANSFER CHARACTERISTICS									
Slew Rate	$V_{OUT} = \pm 10V$ $R_L = 1K\Omega$ $A_V = -5V/V$	4	200	500	-	200	500	-	V/ μS
Open Loop Voltage Gain ③	$R_L = 1K\Omega$ F = 100Hz	4	90	106	-	90	106	-	dB
Gain Bandwidth Product ③	F = 100KHz	4	800	1200	-	800	1200	-	MHz

NOTES:

- ① $R_{SC} = 0\Omega$ and $\pm V_{CC} = 36VDC$ unless otherwise specified.
- ② $A_V = -1$, measured in false summing junction circuit.
- ③ Devices shall be capable of meeting the parameter, but need not be tested. Typical parameters are for reference only.
- ④ Industrial grade devices shall be tested to subgroups 1 and 4 unless otherwise specified.
- ⑤ Military grade devices ("B" suffix) shall be 100% tested to subgroups 1,2,3 and 4.
- ⑥ Subgroups 5 and 6 testing available upon request.
- ⑦ Subgroup 1,4 $T_C = +25^\circ C$
Subgroup 2,5 $T_J = +125^\circ C$
Subgroup 3,6 $T_A = -55^\circ C$

APPLICATION NOTES

HEAT SINKING

To select the correct heat sink for your application, refer to the thermal model and governing equation below.

Thermal Model:

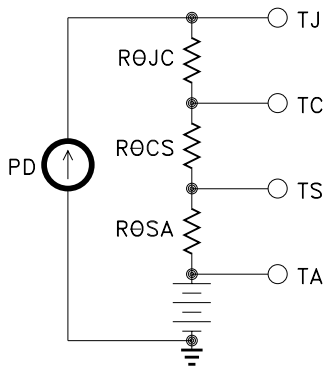

Governing Equation:

$$T_J = P_D \times (R_{\theta JC} + R_{\theta CS} + R_{\theta SA}) + T_A$$

Where

- T_J = Junction Temperature
- P_D = Total Power Dissipation
- $R_{\theta JC}$ = Junction to Case Thermal Resistance
- $R_{\theta CS}$ = Case to Heat Sink Thermal Resistance
- $R_{\theta SA}$ = Heat Sink to Ambient Thermal Resistance
- T_C = Case Temperature
- T_A = Ambient Temperature
- T_S = Sink Temperature

Example:

In our example the amplifier application requires the output to drive a 20 volt peak sine wave across a 400Ω load for 50mA of peak output current. For a worst case analysis we will treat the 50mA peak output current as a D.C. output current. The power supplies shall be set to ±40VDC.

- 1.) Find Driver Power Dissipation

$$P_D = [(\text{quiescent current}) \times (+V_S - (-V_S)) + [(+V_S - V_O) \times I_{OUT}]]$$

$$= [(50\text{mA}) \times (80\text{V})] + [(20\text{V}) \times (0.05\text{A})]$$

$$= 4\text{W} + 1.0\text{W}$$

$$= 5\text{Watts}$$
- 2.) For conservative design, set $T_J = +125^\circ\text{C}$.
- 3.) For this example, worst case $T_A = +50^\circ\text{C}$
- 4.) $R_{\theta JC} = 12^\circ\text{C/W}$ from MSK 1461B Data Sheet
- 5.) $R_{\theta CS} = 0.15^\circ\text{C/W}$ for most thermal greases
- 6.) Rearrange governing equation to solve for $R_{\theta SA}$

$$R_{\theta SA} = ((T_J - T_A)/P_D) - (R_{\theta JC}) - (R_{\theta CS})$$

$$= ((125^\circ\text{C} - 50^\circ\text{C}) / 5\text{W}) - (12^\circ\text{C/W}) - (.15^\circ\text{C/W})$$

$$\cong 2.85^\circ\text{C/W}$$

The heat sink in this example must have a thermal resistance of no more than 2.85°C/W to maintain a junction temperature of no more than $+125^\circ\text{C}$.

CURRENT LIMIT

The output current of the MSK 1461 is internally limited to approximately $\pm 750\text{mA}$ by two 0.8Ω internal current limit resistors. Additional current limit can be achieved through the use of two external current limit resistors. One resistor (+RSC) limits the positive output current and the other (-RSC) limits the negative output current. The value of the current limit resistors can be determined as follows:

$$\pm R_{SC} = [(0.65\text{V} / \pm I_{LIM}) - 0.8\Omega]$$

Since the 0.65V term is obtained from the base to emitter voltage drop of a bipolar transistor, the equation only holds true for $+25^\circ\text{C}$ operation. As case temperature increases, the 0.65V term will decrease making the actual current limit set point decrease slightly.

The following schematic illustrates how to connect each current limit resistor:

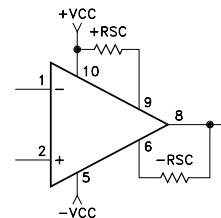

INPUT OFFSET ADJUST CONNECTION

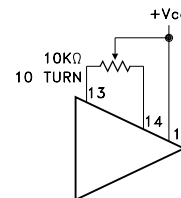

POWER SUPPLY BYPASSING

Both the negative and the positive power supplies must be effectively decoupled with a high and low frequency bypass circuit to avoid power supply induced oscillation. An effective decoupling scheme consists of a $0.1\mu\text{F}$ ceramic capacitor in parallel with a $4.7\mu\text{F}$ tantalum capacitor from each power supply pin to ground.

SAFE OPERATING AREA

Any designer who has worked with power operational amplifiers is familiar with Safe Operating Area (S.O.A.) curves. S.O.A. curves are a graphical representation of the following three power limiting factors of any bipolar transistor output op-amp.

1. Wire Bond Current Carrying Capability
2. Transistor Junction Temperature
3. Secondary Breakdown Limitations

Since the MSK 1461 utilizes a MOSFET output, there are no secondary breakdown limitations and therefore no need for S.O.A. curves. The only limitation on output power is the junction temperature of the output drive transistors.

Whenever possible, junction temperature should be kept below 150°C to ensure high reliability. See "Heat Sinking" for more information involving junction temperature calculations.

TYPICAL PERFORMANCE CURVES

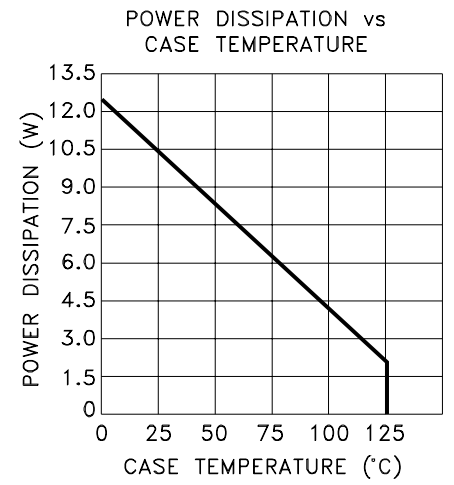
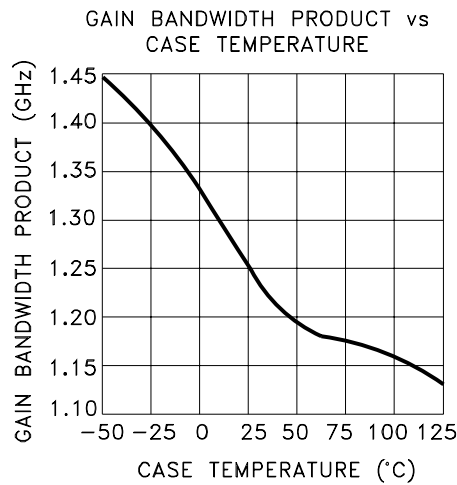
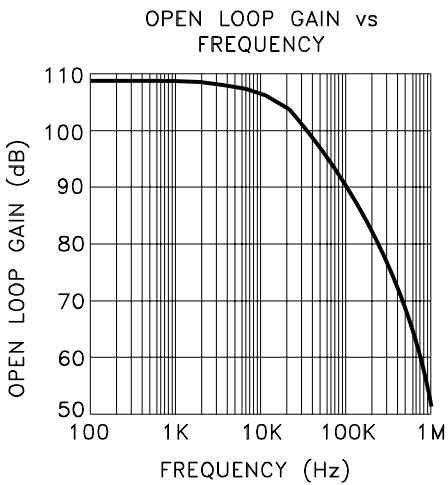
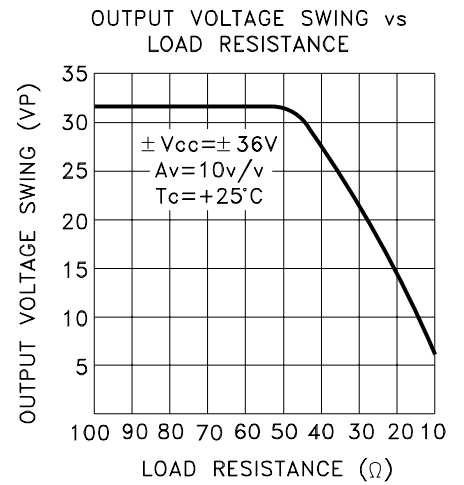
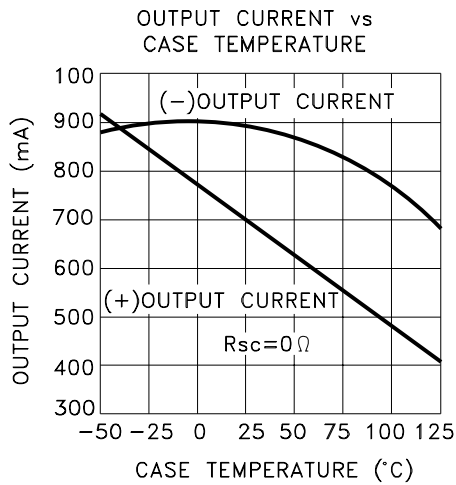
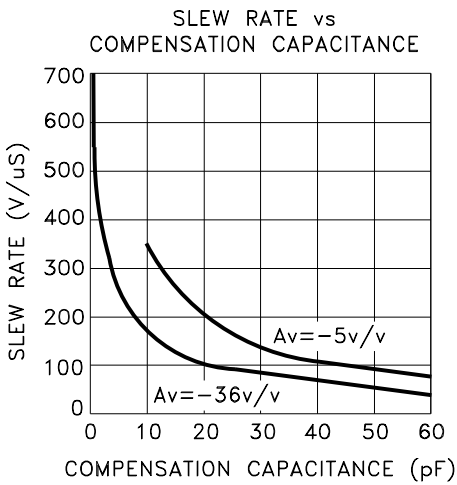
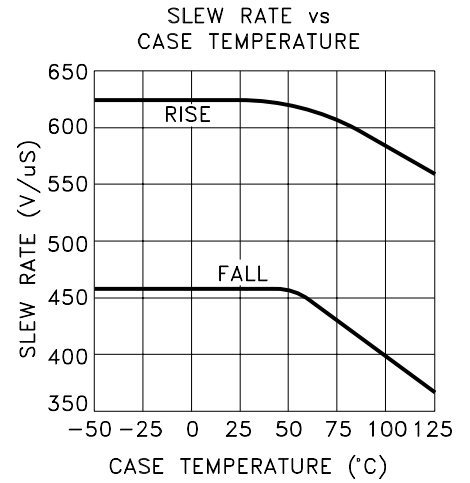
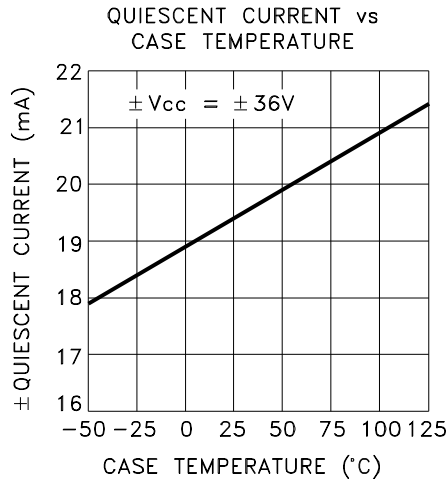
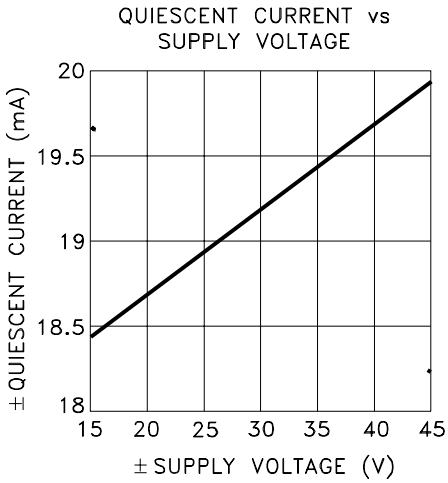

MECHANICAL SPECIFICATIONS

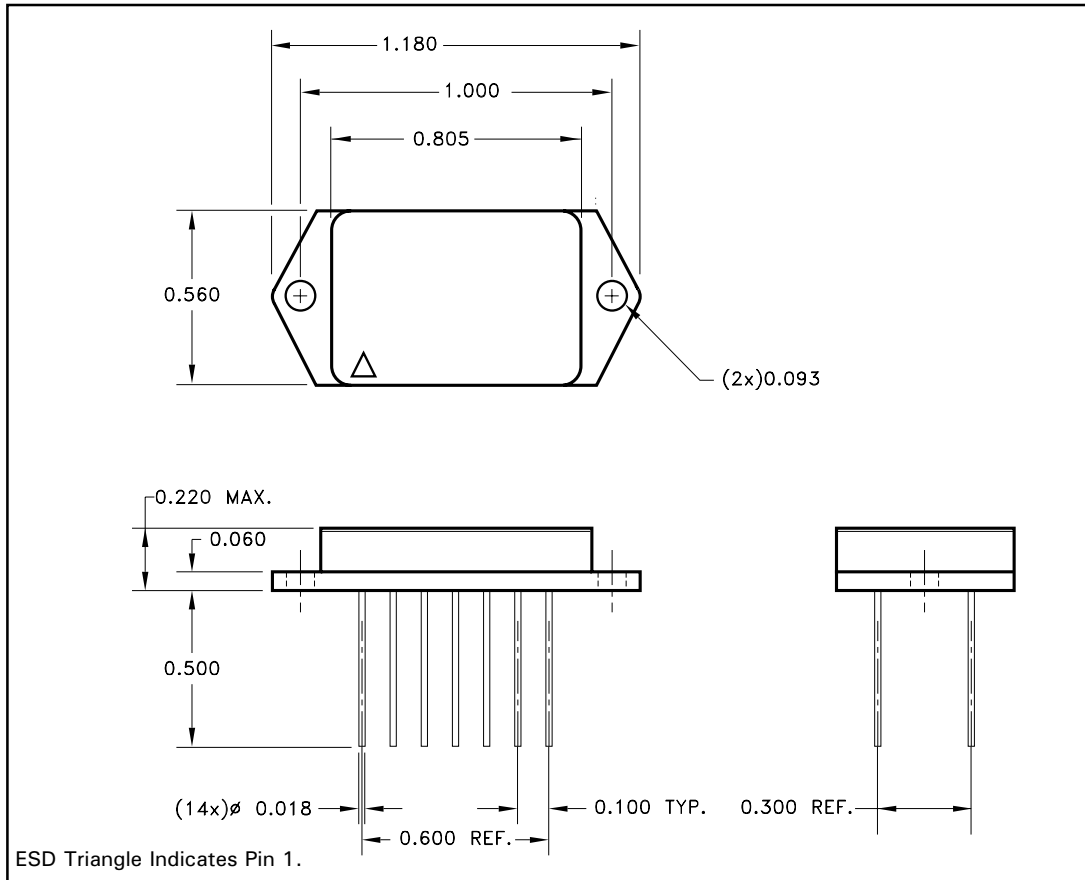

NOTE: ALL DIMENSIONS ARE ± 0.010 UNLESS OTHERWISE LABELED.

ORDERING INFORMATION

Part Number	Screening Level
MSK1461	Industrial
MSK1461B	Military-Mil-PRF-38534

M.S. Kennedy Corp.
 4707 Dey Road, Liverpool, New York 13088
 Phone (315) 701-6751
 FAX (315) 701-6752
 www.mskendy.com

The information contained herein is believed to be accurate at the time of printing. MSK reserves the right to make changes to its products or specifications without notice, however, and assumes no liability for the use of its products.