

PS9506, PS9506L1, PS9506L2, PS9506L3

–NEPOC Series–

R08DS0018EJ0001

Rev.0.01

0.6 A OUTPUT CURRENT, HIGH CMR, IGBT GATE DRIVE, 8-PIN DIP PHOTOCOUPLER

Aug 19, 2010

DESCRIPTION

The PS9506, PS9506L1, PS9506L2 and PS9506L3 are optically coupled isolators containing a GaAlAs LED on the input side and a photo diode, a signal processing circuit and a power output transistor on the output side on one chip. The PS9506 Series is designed specifically for high common mode transient immunity (CMR) and high switching speed.

The PS9506 Series is suitable for driving IGBTs and MOS FETs.

The PS9506 Series is in a plastic DIP (Dual In-line Package).

The PS9506L1 is lead bending type for long creepage distance.

The PS9506L2 is lead bending type for long creepage distance (Gull-wing) for surface mount.

The PS9506L3 is lead bending type (Gull-wing) for surface mounting.

FEATURES

- Long creepage distance (8 mm MIN.: PS9506L1, PS9506L2)
- Peak output current (0.6 A MAX., 0.4 A MIN.)
- High speed switching (t_{PLH} , t_{PHL} = 0.4 μ S MAX.)
- High common mode transient immunity (CM_H , CM_L = ± 25 kV/ μ S MIN.)
- Embossed tape product : PS9506L2-E3: 1 000 pcs/reel
: PS9506L3-E3: 1 000 pcs/reel
- Pb-Free product

APPLICATIONS

- IGBT, Power MOS FET Gate Driver
- Industrial inverter
- IH (Induction Heating)

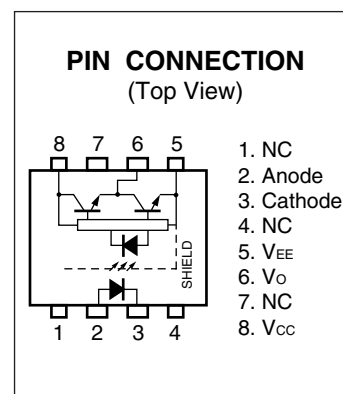

PACKAGE DIMENSIONS (UNIT: mm)

DIP Type

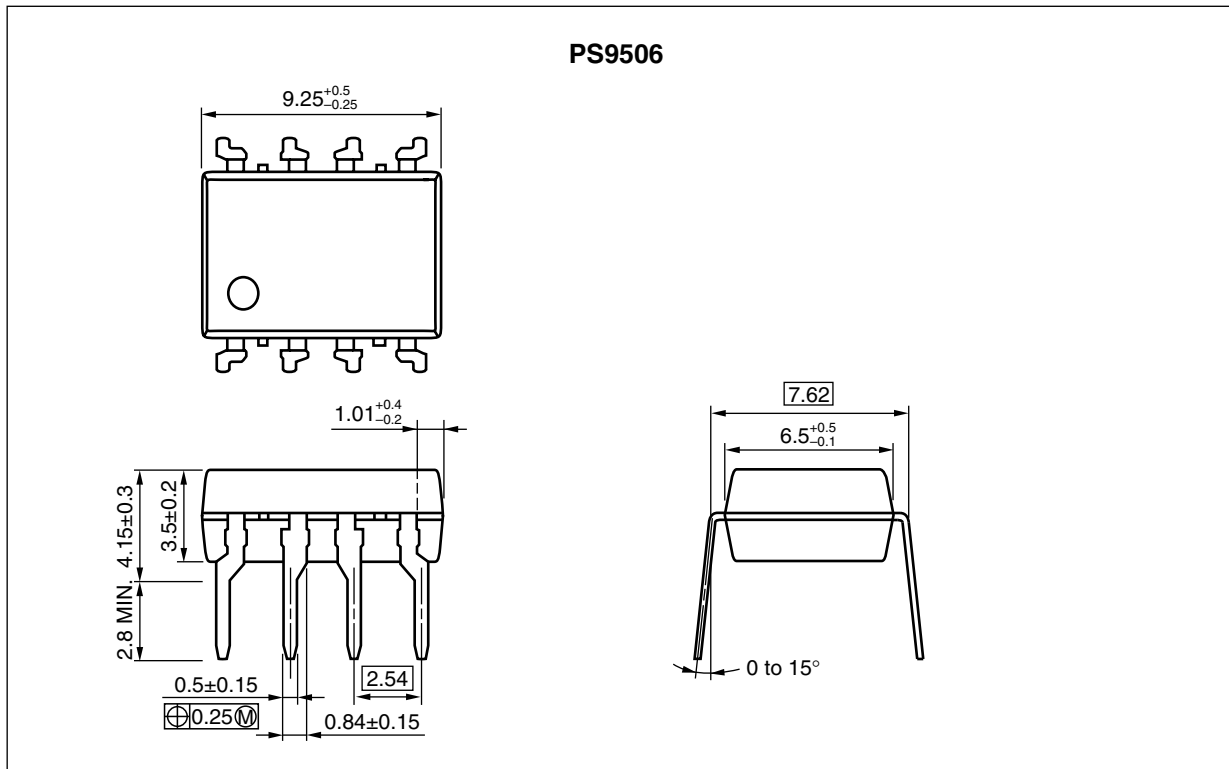

Lead Bending Type (Gull-wing) For Surface Mount

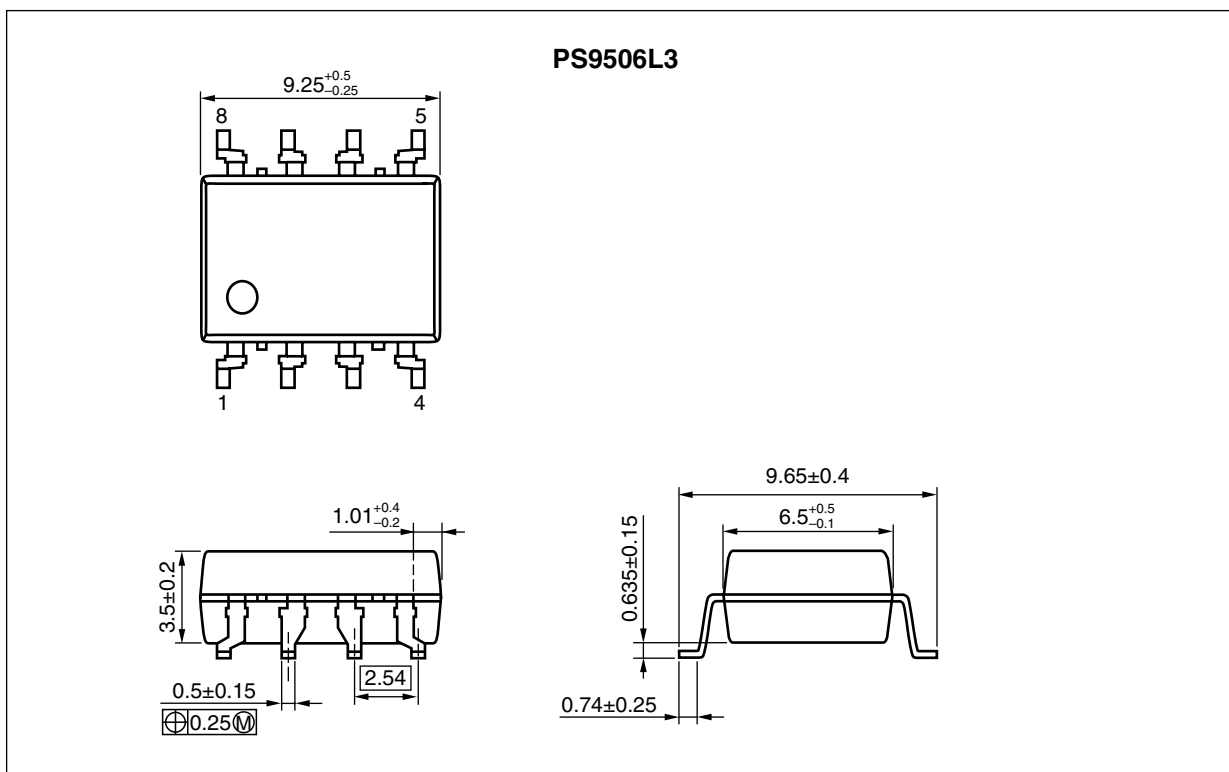

Lead Bending Type For Long Creepage Distance

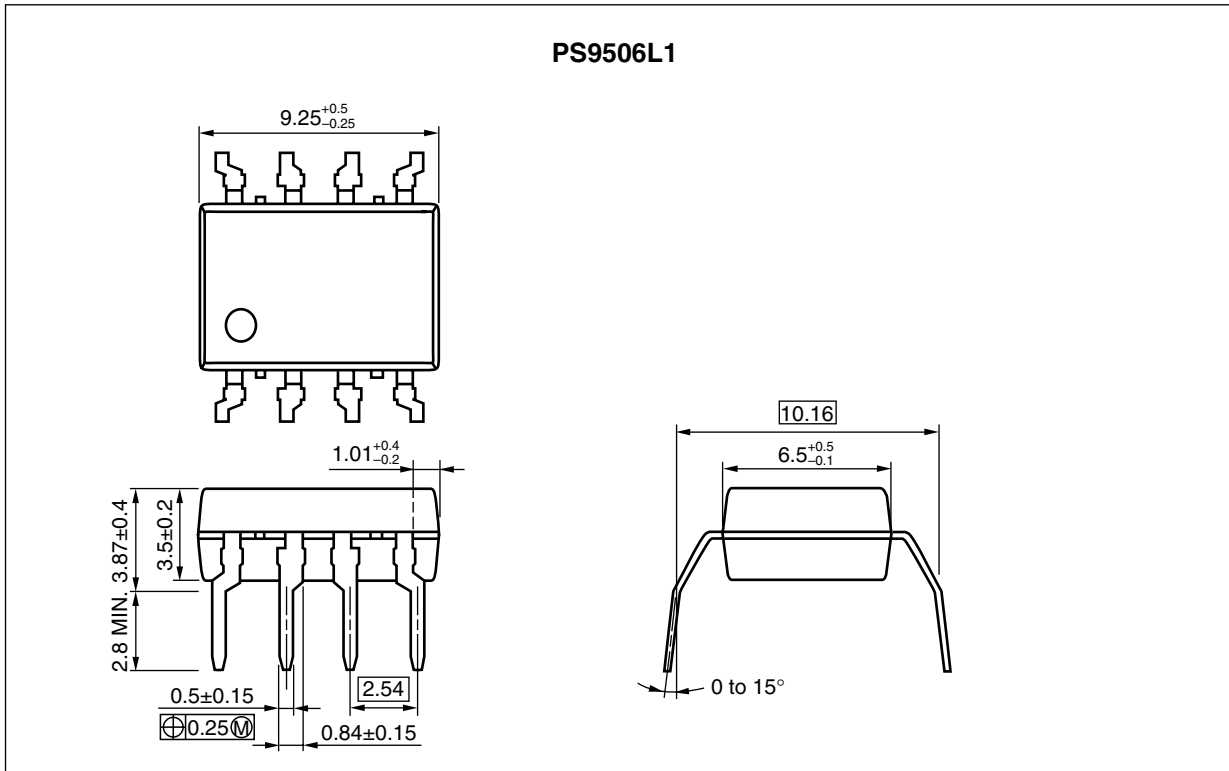

Lead Bending Type (Gull-wing) For Long Creepage Distance (Surface Mount)

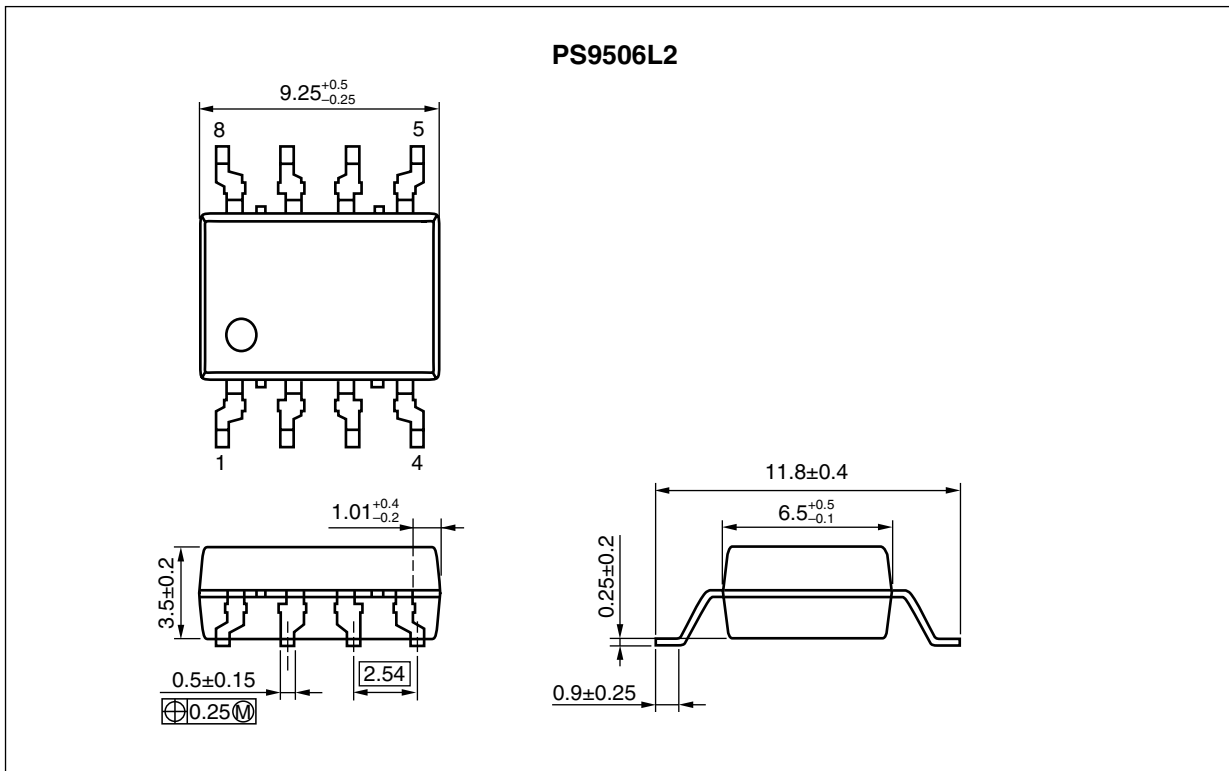

PHOTOCOUPLER CONSTRUCTION

Parameter	PS9506 ,PS9506L3	PS9506L1, PS9506L2
Air Distance (MIN.)	7 mm	8 mm
Outer Creepage Distance (MIN.)	7 mm	8 mm
Isolation Distance (MIN.)	0.4 mm	0.4 mm

FUNCTIONAL DIAGRAM

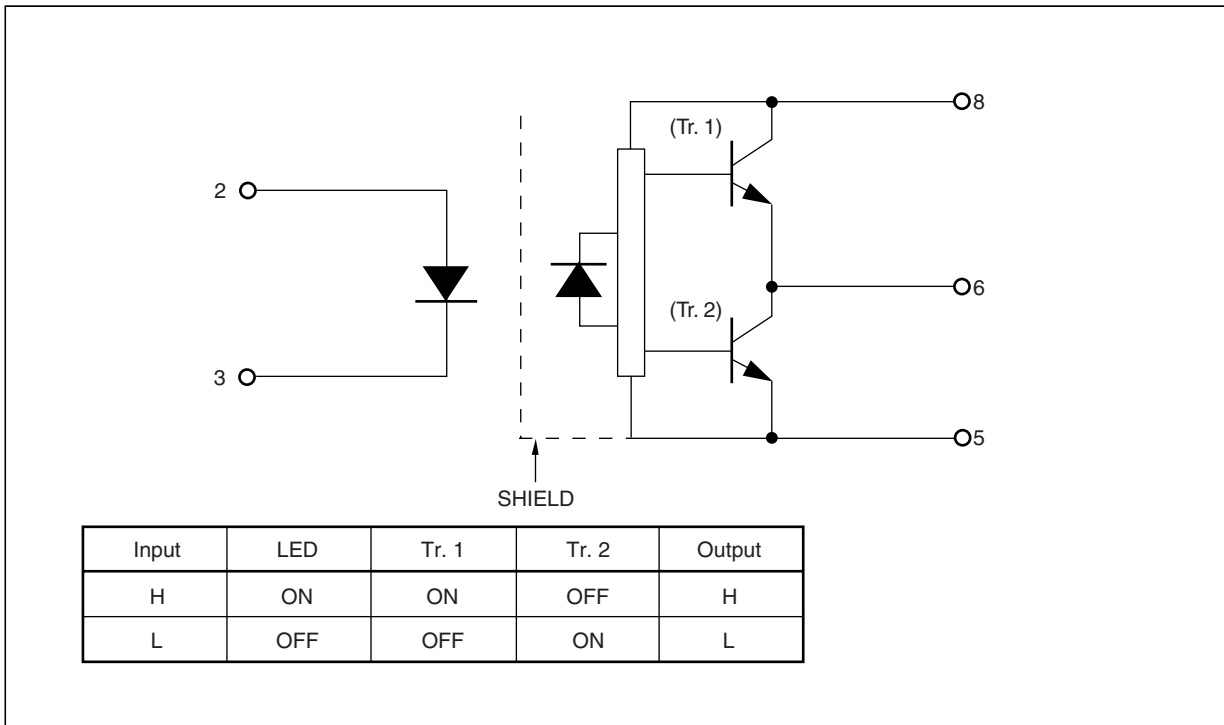

MARKING EXAMPLE

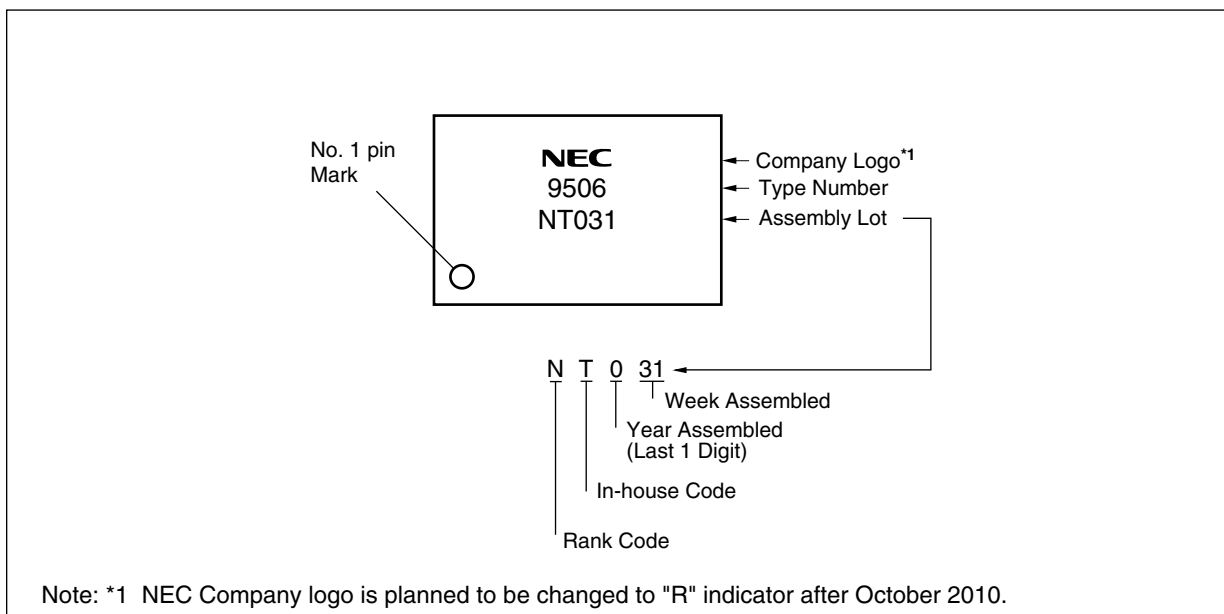

ABSOLUTE MAXIMUM RATINGS ($T_A = 25^\circ\text{C}$, unless otherwise specified)

Parameter	Symbol	Ratings	Unit	
Diode	Forward Current	I_F	25	mA
	Peak Transient Forward Current (Pulse Width < 1 μs)	$I_{F(\text{TRAN})}$	1.0	A
	Reverse Voltage	V_R	5	V
	Power Dissipation *1	P_D	45	mW
Detector	High Level Peak Output Current *2	$I_{OH(\text{PEAK})}$	0.6	A
	Low Level Peak Output Current *2	$I_{OL(\text{PEAK})}$	0.6	A
	Supply Voltage	$(V_{CC}-V_{EE})$	0 to 35	V
	Output Voltage	V_O	0 to V_{CC}	V
	Power Dissipation *3	P_C	250	mW
Isolation Voltage *4	BV	5 000	Vr.m.s.	
Operating Frequency *5	f	50	kHz	
Operating Ambient Temperature	T_A	-40 to +110	$^\circ\text{C}$	
Storage Temperature	T_{stg}	-55 to +125	$^\circ\text{C}$	

Notes: *1. Reduced to 1.2 mW/ $^\circ\text{C}$ at $T_A = 85^\circ\text{C}$ or more.

*2. Maximum pulse width = 10 μs , Maximum duty cycle = 0.2%

*3. Reduced to 5.5 mW/ $^\circ\text{C}$ at $T_A = 75^\circ\text{C}$ or more.

*4. AC voltage for 1 minute at $T_A = 25^\circ\text{C}$, RH = 60% between input and output.
 Pins 1-4 shorted together, 5-8 shorted together.

*5. $I_{OH(\text{PEAK})} \leq 0.4 \text{ A}$ ($\leq 2.0 \mu\text{s}$), $I_{OL(\text{PEAK})} \leq 0.4 \text{ A}$ ($\leq 2.0 \mu\text{s}$)

RECOMMENDED OPERATING CONDITIONS

Parameter	Symbol	MIN.	TYP.	MAX.	Unit
Supply Voltage	$(V_{CC}-V_{EE})$	10		30	V
Forward Current (ON)	$I_{F(\text{ON})}$	8		12	mA
Forward Voltage (OFF)	$V_{F(\text{OFF})}$	-2		0.8	V
Operating Ambient Temperature	T_A	-40		110	$^\circ\text{C}$

ELECTRICAL CHARACTERISTICS ($T_A = -40$ to $+110^\circ\text{C}$, $V_{CC} = 10$ to 30 V, I_F (ON) = 8 to 12 mA, V_F (OFF) = -2 to 0.8 V, $V_{EE} = \text{GND}$, unless otherwise specified)

Parameter		Symbol	Conditions	MIN.	TYP.* ¹	MAX.	Unit
Diode	Forward Voltage	V_F	$I_F = 10$ mA, $T_A = 25^\circ\text{C}$	1.2	1.56	1.8	V
	Reverse Current	I_R	$V_R = 3$ V, $T_A = 25^\circ\text{C}$			10	μA
	Input Capacitance	C_{IN}	$f = 1$ MHz, $V_F = 0$ V, $T_A = 25^\circ\text{C}$		30		pF
Detector	High Level Output Current	I_{OH}	$V_O = (V_{CC}-4 \text{ V})$ ^{*2}	0.2			A
			$V_O = (V_{CC}-10 \text{ V})$ ^{*3}	0.4	0.5		
	Low Level Output Current	I_{OL}	$V_O = (V_{EE}+2.5 \text{ V})$ ^{*2}	0.2	0.4		A
			$V_O = (V_{EE}+10 \text{ V})$ ^{*3}	0.4	0.5		
	High Level Output Voltage	V_{OH}	$I_O = -100$ mA ^{*4}	$V_{CC}-4.0$	$V_{CC}-1.8$		V
	Low Level Output Voltage	V_{OL}	$I_O = 100$ mA		0.4	1.0	V
	High Level Supply Current	I_{CCH}	$V_O = \text{open}$, $I_F = 8$ to 12 mA		0.7	3.0	mA
	Low Level Supply Current	I_{CCL}	$V_O = \text{open}$, $V_F = -2$ to $+0.8$ V		1.2	3.0	mA
Coupled	Threshold Input Current (L \rightarrow H)	I_{FLH}	$I_O = 0$ mA, $V_O > 5$ V			7.0	mA
	Threshold Input Voltage (H \rightarrow L)	V_{FHL}	$I_O = 0$ mA, $V_O < 5$ V	0.8			V
	Isolation Capacitance	C_{I-O}	$V_F = 0$ V, $f = 1$ MHz, $T_A = 25^\circ\text{C}$		0.7		pF

Notes: *1. Typical values at $T_A = 25^\circ\text{C}$, $V_{CC}-V_{EE} = 30$ V.

*2. Maximum pulse width = 50 μs , Maximum duty cycle = 0.5%.

*3. Maximum pulse width = 10 μs , Maximum duty cycle = 0.2%.

*4. V_{OH} is measured with the DC load current in this testing.

SWITCHING CHARACTERISTICS ($T_A = -40$ to $+110^\circ\text{C}$, $V_{CC} = 10$ to 30 V , $I_F(\text{ON}) = 8$ to 12 mA , $V_F(\text{OFF}) = -2$ to 0.8 V , $V_{EE} = \text{GND}$, unless otherwise specified)

Parameter	Symbol	Conditions	MIN.	TYP.*1	MAX.	Unit
Propagation Delay Time (L → H)	t_{PLH}	$R_g = 47\ \Omega$, $C_g = 3\ \text{nF}$, $f = 10\ \text{kHz}$, Duty Cycle = 50%*2, $I_F = 10\ \text{mA}$, $V_{CC} = 30\ \text{V}$	0.05	0.18	0.4	μs
Propagation Delay Time (H → L)	t_{PHL}		0.05	0.18	0.4	μs
Pulse Width Distortion (PWD)	$ t_{PHL} - t_{PLH} $		0.25			μs
Propagation Delay Time (Difference Between Any Two Products)	$t_{PHL} - t_{PLH}$		-0.3		0.3	μs
Rise Time	t_r			50		ns
Fall Time	t_f			50		ns
Common Mode Transient Immunity at High Level Output	$ CM_H $		$T_A = 25^\circ\text{C}$, $I_F = 10\ \text{mA}$, $V_{CC} = 30\ \text{V}$, $V_{CM} = 1.5\ \text{kV}$, $V_{O(\text{MIN.})} = 26\ \text{V}$	25		
Common Mode Transient Immunity at Low Level Output	$ CM_L $	$T_A = 25^\circ\text{C}$, $I_F = 0\ \text{mA}$, $V_{CC} = 30\ \text{V}$, $V_{CM} = 1.5\ \text{kV}$, $V_{O(\text{MAX.})} = 1\ \text{V}$	25			$\text{kV}/\mu\text{s}$

Notes: *1. Typical values at $T_A = 25^\circ\text{C}$, $V_{CC} - V_{EE} = 30\ \text{V}$.

*2. This load condition is equivalent to the IGBT load at 1 200 V/25 A.

TAPING SPECIFICATIONS (UNIT: mm)

Outline and Dimensions (Tape)

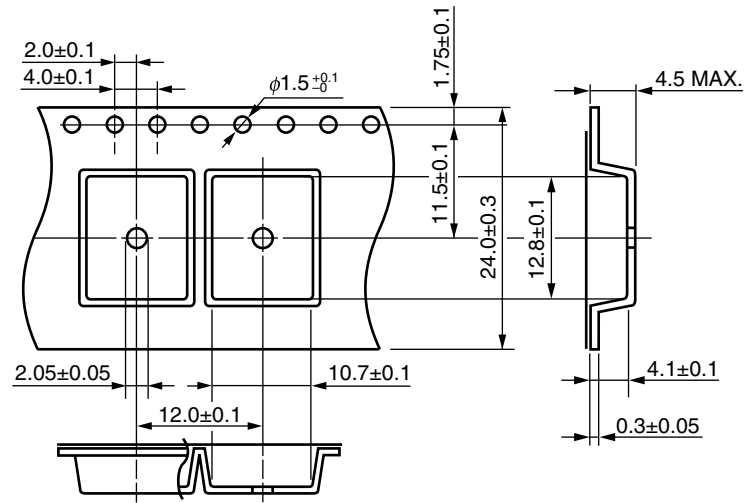

Tape Direction

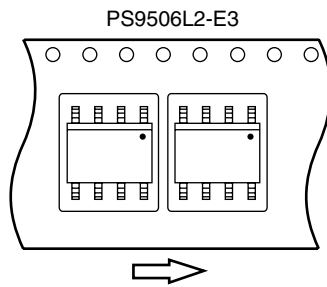

Outline and Dimensions (Reel)

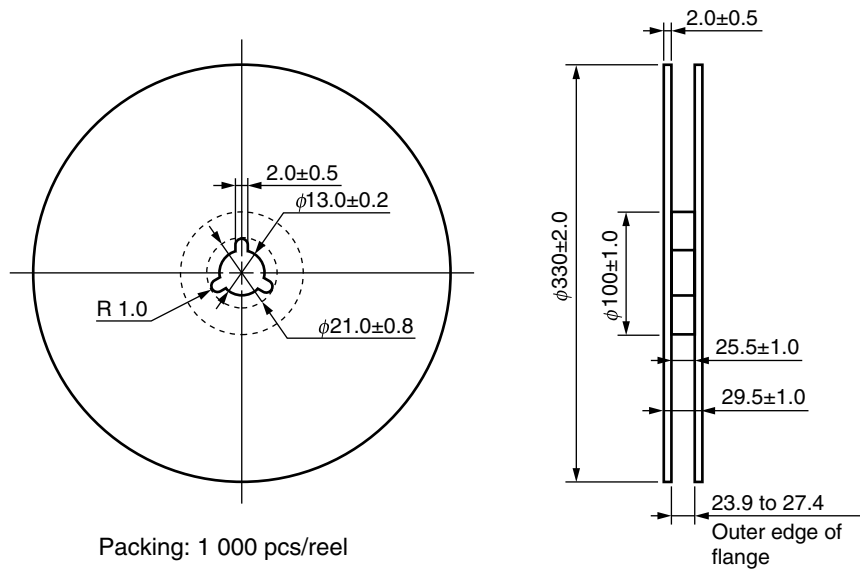

Outline and Dimensions (Tape)

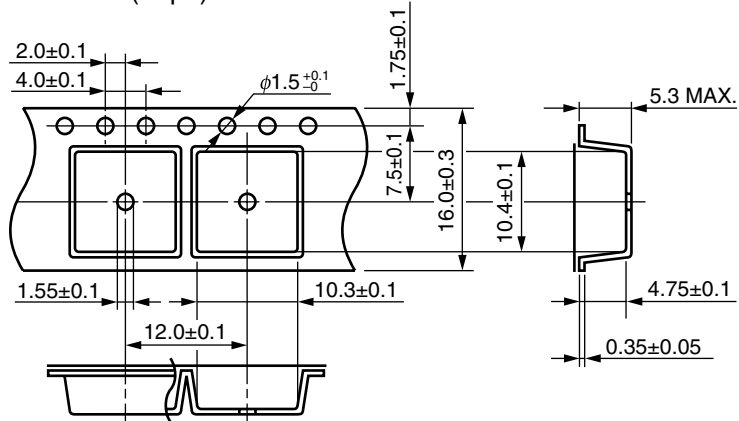

Tape Direction

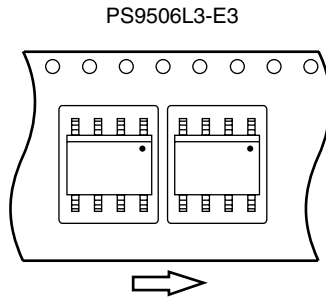

Outline and Dimensions (Reel)

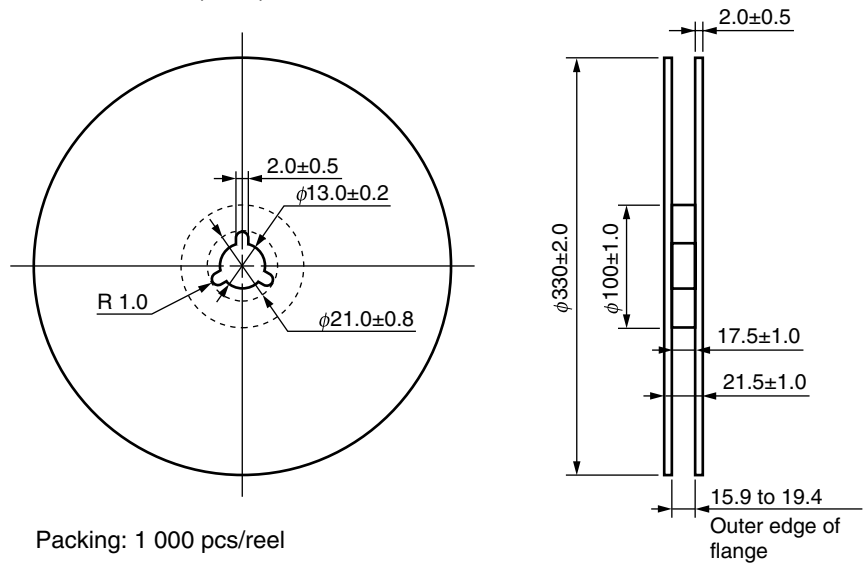

RECOMMENDED MOUNT PAD DIMENSIONS (UNIT: mm)

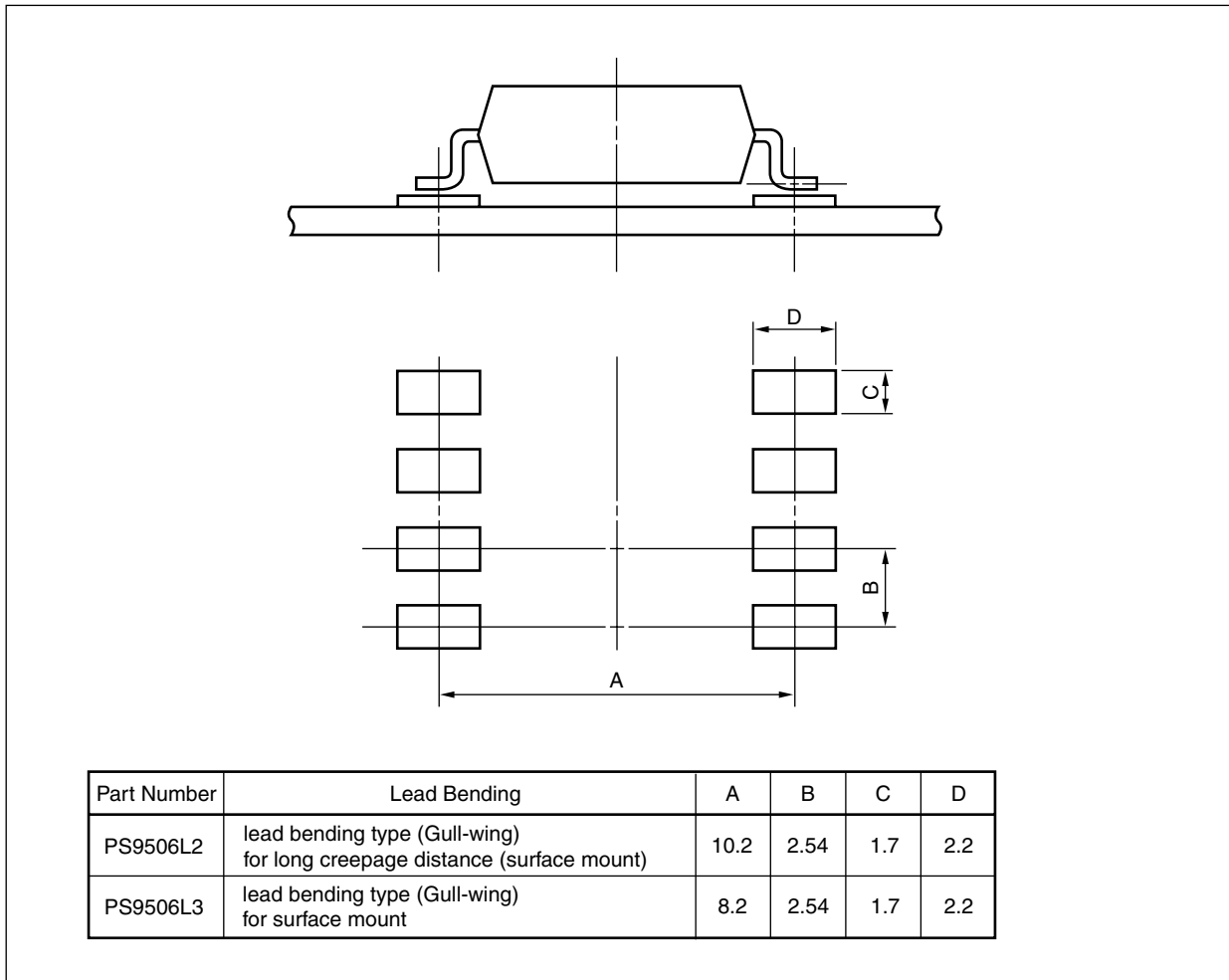

NOTES ON HANDLING

CAUTIONS REGARDING NOISE

Be aware that when voltage is applied suddenly between the photocoupler's input and output at startup, the output transistor may enter the on state, even if the voltage is within the absolute maximum ratings.

USAGE CAUTIONS

1. This product is weak for static electricity by designed with high-speed integrated circuit so protect against static electricity when handling.
2. Board designing
 - (1) By-pass capacitor of more than 0.1 μ F is used between V_{CC} and GND near device. Also, ensure that the distance between the leads of the photocoupler and capacitor is no more than 10 mm.
 - (2) In order to avoid malfunctions and characteristics degradation, IGBT collector or emitter traces should not be closed to the LED input.
 - (3) Pins 1, 4 (which is an NC^{*1} pin) can either be connected directly to the GND pin on the LED side or left open. Also, Pin 7 (which is an NC^{*1} pin) can either be connected directly to the GND pin on the detector side or left open.
Unconnected pins should not be used as a bypass for signals or for any other similar purpose because this may degrade the internal noise environment of the device.
Note: *1. NC: Non-Connection (No Connection).
3. Make sure the rise/fall time of the forward current is 0.5 μ s or less.
4. In order to avoid malfunctions, make sure the rise/fall slope of the supply voltage is 3 V/ μ s or less.
5. Avoid storage at a high temperature and high humidity.

<p>Caution GaAs Products</p>	<p>This product uses gallium arsenide (GaAs). GaAs vapor and powder are hazardous to human health if inhaled or ingested, so please observe the following points.</p> <ul style="list-style-type: none">• Follow related laws and ordinances when disposing of the product. If there are no applicable laws and/or ordinances, dispose of the product as recommended below.<ol style="list-style-type: none">1. Commission a disposal company able to (with a license to) collect, transport and dispose of materials that contain arsenic and other such industrial waste materials.2. Exclude the product from general industrial waste and household garbage, and ensure that the product is controlled (as industrial waste subject to special control) up until final disposal.• Do not burn, destroy, cut, crush, or chemically dissolve the product.• Do not lick the product or in any way allow it to enter the mouth.
-------------------------------------	--------------------------------------------------------------------------------------------------------------------------------------------------------------------------------------------------------------------------------------------------------------------------------------------------------------------------------------------------------------------------------------------------------------------------------------------------------------------------------------------------------------------------------------------------------------------------------------------------------------------------------------------------------------------------------------------------------------------------------------------------------------------------------------------------------------------------------------------------------------------------------------------------------------------------------------------------------------------------------------------

Revision History	PS9506,PS9506L1,PS9506L2,PS9506L3 Preliminary Data Sheet
-------------------------	-----------------------------------------------------------------

Rev.	Date	Description	
		Page	Summary
0.01	Aug 19, 2010	-	First edition issued

All trademarks and registered trademarks are the property of their respective owners.

Notice

- All information included in this document is current as of the date this document is issued. Such information, however, is subject to change without any prior notice. Before purchasing or using any Renesas Electronics products listed herein, please confirm the latest product information with a Renesas Electronics sales office. Also, please pay regular and careful attention to additional and different information to be disclosed by Renesas Electronics such as that disclosed through our website.
- Renesas Electronics does not assume any liability for infringement of patents, copyrights, or other intellectual property rights of third parties by or arising from the use of Renesas Electronics products or technical information described in this document. No license, express, implied or otherwise, is granted hereby under any patents, copyrights or other intellectual property rights of Renesas Electronics or others.
- You should not alter, modify, copy, or otherwise misappropriate any Renesas Electronics product, whether in whole or in part.
- Descriptions of circuits, software and other related information in this document are provided only to illustrate the operation of semiconductor products and application examples. You are fully responsible for the incorporation of these circuits, software, and information in the design of your equipment. Renesas Electronics assumes no responsibility for any losses incurred by you or third parties arising from the use of these circuits, software, or information.
- When exporting the products or technology described in this document, you should comply with the applicable export control laws and regulations and follow the procedures required by such laws and regulations. You should not use Renesas Electronics products or the technology described in this document for any purpose relating to military applications or use by the military, including but not limited to the development of weapons of mass destruction. Renesas Electronics products and technology may not be used for or incorporated into any products or systems whose manufacture, use, or sale is prohibited under any applicable domestic or foreign laws or regulations.
- Renesas Electronics has used reasonable care in preparing the information included in this document, but Renesas Electronics does not warrant that such information is error free. Renesas Electronics assumes no liability whatsoever for any damages incurred by you resulting from errors in or omissions from the information included herein.
- Renesas Electronics products are classified according to the following three quality grades: "Standard", "High Quality", and "Specific". The recommended applications for each Renesas Electronics product depends on the product's quality grade, as indicated below. You must check the quality grade of each Renesas Electronics product before using it in a particular application. You may not use any Renesas Electronics product for any application categorized as "Specific" without the prior written consent of Renesas Electronics. Further, you may not use any Renesas Electronics product for any application for which it is not intended without the prior written consent of Renesas Electronics. Renesas Electronics shall not be in any way liable for any damages or losses incurred by you or third parties arising from the use of any Renesas Electronics product for an application categorized as "Specific" or for which the product is not intended where you have failed to obtain the prior written consent of Renesas Electronics. The quality grade of each Renesas Electronics product is "Standard" unless otherwise expressly specified in a Renesas Electronics data sheets or data books, etc.
"Standard": Computers; office equipment; communications equipment; test and measurement equipment; audio and visual equipment; home electronic appliances; machine tools; personal electronic equipment; and industrial robots.
"High Quality": Transportation equipment (automobiles, trains, ships, etc.); traffic control systems; anti-disaster systems; anti-crime systems; safety equipment; and medical equipment not specifically designed for life support.
"Specific": Aircraft; aerospace equipment; submersible repeaters; nuclear reactor control systems; medical equipment or systems for life support (e.g. artificial life support devices or systems), surgical implantations, or healthcare intervention (e.g. excision, etc.), and any other applications or purposes that pose a direct threat to human life.
- You should use the Renesas Electronics products described in this document within the range specified by Renesas Electronics, especially with respect to the maximum rating, operating supply voltage range, movement power voltage range, heat radiation characteristics, installation and other product characteristics. Renesas Electronics shall have no liability for malfunctions or damages arising out of the use of Renesas Electronics products beyond such specified ranges.
- Although Renesas Electronics endeavors to improve the quality and reliability of its products, semiconductor products have specific characteristics such as the occurrence of failure at a certain rate and malfunctions under certain use conditions. Further, Renesas Electronics products are not subject to radiation resistance design. Please be sure to implement safety measures to guard them against the possibility of physical injury, and injury or damage caused by fire in the event of the failure of a Renesas Electronics product, such as safety design for hardware and software including but not limited to redundancy, fire control and malfunction prevention, appropriate treatment for aging degradation or any other appropriate measures. Because the evaluation of microcomputer software alone is very difficult, please evaluate the safety of the final products or system manufactured by you.
- Please contact a Renesas Electronics sales office for details as to environmental matters such as the environmental compatibility of each Renesas Electronics product. Please use Renesas Electronics products in compliance with all applicable laws and regulations that regulate the inclusion or use of controlled substances, including without limitation, the EU RoHS Directive. Renesas Electronics assumes no liability for damages or losses occurring as a result of your noncompliance with applicable laws and regulations.
- This document may not be reproduced or duplicated, in any form, in whole or in part, without prior written consent of Renesas Electronics.
- Please contact a Renesas Electronics sales office if you have any questions regarding the information contained in this document or Renesas Electronics products, or if you have any other inquiries.
(Note 1) "Renesas Electronics" as used in this document means Renesas Electronics Corporation and also includes its majority-owned subsidiaries.
(Note 2) "Renesas Electronics product(s)" means any product developed or manufactured by or for Renesas Electronics.



SALES OFFICES

Renesas Electronics Corporation

<http://www.renesas.com>

Refer to "<http://www.renesas.com/>" for the latest and detailed information.

Renesas Electronics America Inc.
2880 Scott Boulevard Santa Clara, CA 95050-2554, U.S.A.
Tel: +1-408-588-6000, Fax: +1-408-588-6130

Renesas Electronics Canada Limited
1101 Nicholson Road, Newmarket, Ontario L3Y 9C3, Canada
Tel: +1-905-898-5441, Fax: +1-905-898-3220

Renesas Electronics Europe Limited
Dukes Meadow, Millboard Road, Bourne End, Buckinghamshire, SL8 5FH, U.K
Tel: +44-1628-585-100, Fax: +44-1628-585-900

Renesas Electronics Europe GmbH
Arcadiastrasse 10, 40472 Düsseldorf, Germany
Tel: +49-211-6503-0, Fax: +49-211-6503-1327

Renesas Electronics (China) Co., Ltd.
7th Floor, Quantum Plaza, No.27 ZhichunLu Haidian District, Beijing 100083, P.R.China
Tel: +86-10-8235-1155, Fax: +86-10-8235-7679

Renesas Electronics (Shanghai) Co., Ltd.
Unit 204, 205, AZIA Center, No.1233 Lujiazui Ring Rd., Pudong District, Shanghai 200120, China
Tel: +86-21-5877-1818, Fax: +86-21-6887-7858 / -7898

Renesas Electronics Hong Kong Limited
Unit 1601-1613, 16/F., Tower 2, Grand Century Place, 193 Prince Edward Road West, Mongkok, Kowloon, Hong Kong
Tel: +852-2886-9318, Fax: +852-2886-9022/9044

Renesas Electronics Taiwan Co., Ltd.
7F, No. 363 Fu Shing North Road Taipei, Taiwan, R.O.C.
Tel: +886-2-8175-9600, Fax: +886-2-8175-9670

Renesas Electronics Singapore Pte. Ltd.
1 HarbourFront Avenue, #06-10, Keppel Bay Tower, Singapore 098632
Tel: +65-6213-0200, Fax: +65-6278-8001

Renesas Electronics Malaysia Sdn.Bhd.
Unit 906, Block B, Menara Amcorp, Amcorp Trade Centre, No. 18, Jln Persiaran Barat, 46050 Petaling Jaya, Selangor Darul Ehsan, Malaysia
Tel: +60-3-7955-9390, Fax: +60-3-7955-9510

Renesas Electronics Korea Co., Ltd.
11F., Samik Laviel'or Bldg., 720-2 Yeoksam-Dong, Kangnam-Ku, Seoul 135-080, Korea
Tel: +82-2-558-3737, Fax: +82-2-558-5141