

# Am7942

## Subscriber Line Interface Circuit

### DISTINCTIVE CHARACTERISTICS

- Programmable constant-current feed
- Receive current gain = 200
- Programmable loop-detect threshold
- Low standby power
- Performs polarity reversal
- Ground-key detector
- Pin for external ground-key noise filter capacitor
- Test relay driver option (PLCC only)
- Tip Open state for ground-start lines
- -19 V to -58 V battery operation
- Ideal for PBX and KTS applications
- On-chip switching regulator for low-power dissipation
- Can be used with or without the on-chip switching regulator
- Two-wire impedance set by single external impedance
- On-hook transmission

### BLOCK DIAGRAM

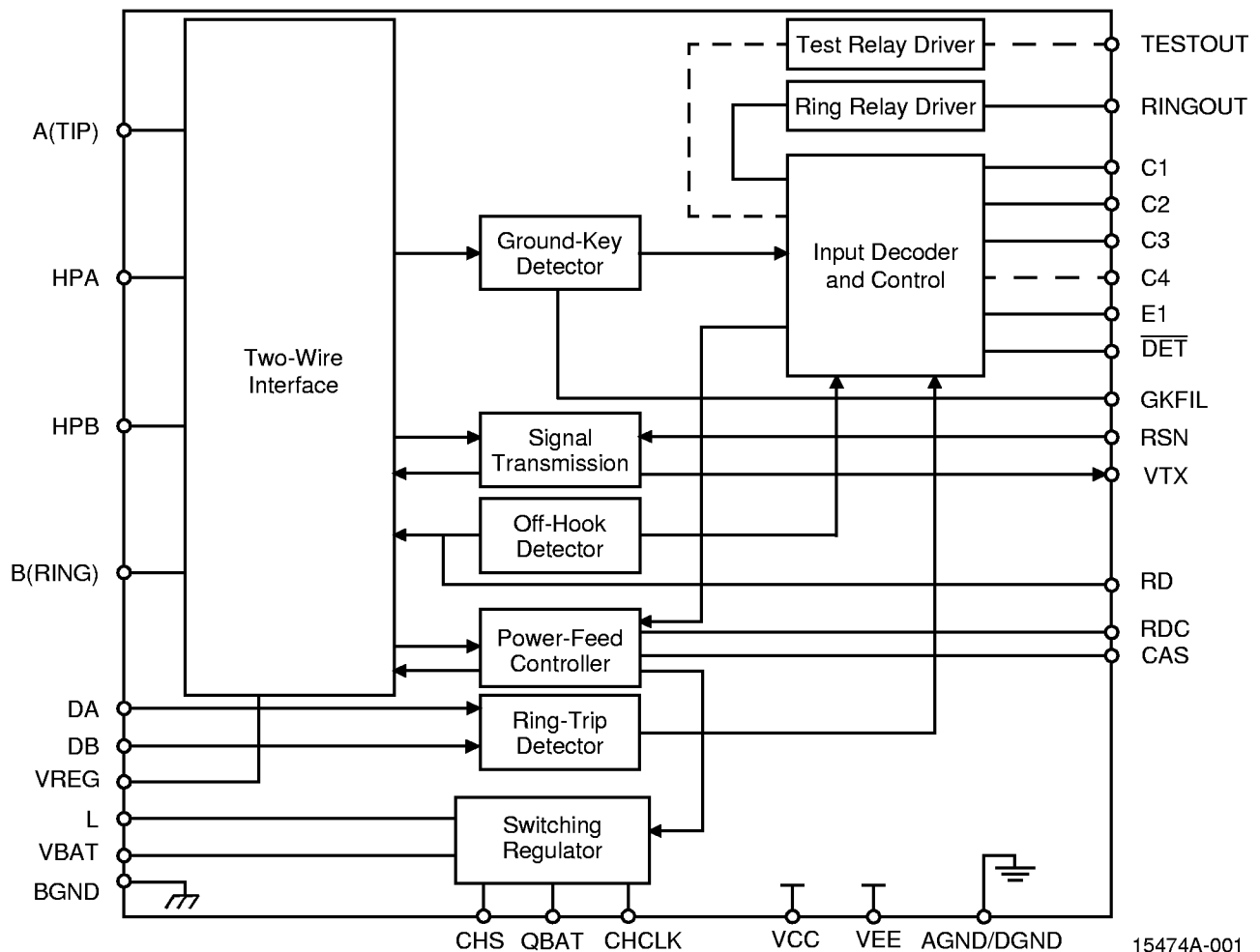

**ORDERING INFORMATION**

**Standard Products**

AMD standard products are available in several packages and operating ranges. The order number (Valid Combination) is formed by a combination of the elements below.

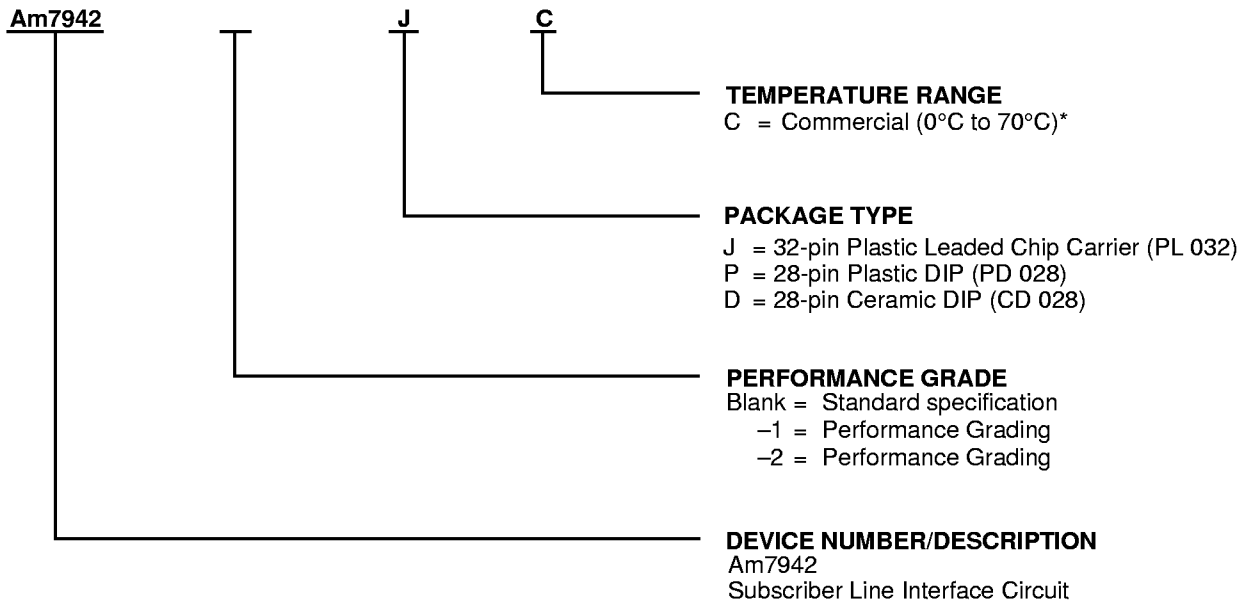

Valid Combinations		
Am7942	-1	DC
	-2	JC
		PC

**Valid Combinations**

Valid Combinations lists configurations planned to be supported in volume for this device. Consult the local AMD sales office to confirm availability of specific valid combinations, to check on newly released combinations, and to obtain additional data on AMD standard military grade products.

**Note:**

\* Functionality of the device from 0°C to +70°C is guaranteed by production testing. Performance from -40°C to +85°C is guaranteed by characterization and periodic sampling of production units.



## PIN DESCRIPTIONS

Pin Names	Type	Description
AGND/DGND	Gnd	Analog and Digital ground.
A(TIP)	Output	Output of A(TIP) power amplifier.
BGND	Gnd	Battery (power) ground.
B(RING)	Output	Output of B(RING) power amplifier.
C3–C1	Input	Decoder. TTL compatible. C3 is MSB and C1 is LSB.
C4	Input	Test Relay Driver Command. TTL compatible. A logic Low enables the driver. See Note 3.
CAS	Capacitor	Anti-saturation pin for capacitor to filter reference voltage when operating in anti-saturation region.
CHCLK	Input	Chopper Clock. Input to switching regulator (TTL compatible). Freq = 256 kHz (typ). See Note 1.
CHS	Input	Chopper Stabilization. (See Note 1) Connection for external chopper stabilizing components.
DA	Input	Ring-trip negative. Negative input to ring-trip comparator.
DB	Input	Ring-trip positive. Positive input to ring-trip comparator.
DET	Output	Switchhook detector. When enabled, a logic Low indicates the selected detector is tripped. The detector is selected by the logic inputs (C3–C1, E1). The output is open-collector with a built-in 15 k $\Omega$ pull-up resistor.
E1	Input	Ground-Key Enable. E1 = High connects the ground-key detector to DET. E1 = Low connects the off-hook or ring-trip detector to DET.
GKFIL	—	Connection for external ground-key, noise-filter capacitor. See Notes 2 and 3.
HPA	Capacitor	High-Pass Filter Capacitor. A(TIP) side of high-pass filter capacitor.
HPB	Capacitor	High-Pass Filter Capacitor. B(RING) side of high-pass filter capacitor.
L	Output (See Note 1)	Switching Regulator Power Transistor. Connection point for filter inductor and anode of catch diode. Has up to 60 V of pulse waveform on it and must be isolated from sensitive circuits. Keep the diode connections short because of the high currents and high di/dt.
QBAT	Battery	Quiet Battery. (See Note 1). Filtered battery supply for the signal processing circuits
RD	Resistor	Detector resistor. Detector threshold set and filter pin.
RDC	Resistor	DC feed resistor. Connection point for the DC feed current programming network. The other end of the network connects to the receiver summing node (RSN).
RINGOUT	Output	Ring Relay Driver. Open-collector driver with emitter internally connected to BGND.
RSN	Input	Receive Summing Node. The metallic current (AC and DC) between A(TIP) and B(RING) is equal to 500 x the current into this pin. The networks that program receive gain, two-wire impedance, and feed current all connect to this node.
TESTOUT	Output	Test Relay Driver. Open collector driver with emitter internally connected to BGND. See Note 3.
TP	Thermal	Thermal pin. Connection for heat dissipation. Internally connected to substrate (QBAT). Leave as open circuit or connected to QBAT. In both cases, the TP pins can connect to an area of copper on the board to enhance heat dissipation
VBAT	Battery	Battery supply.
VCC	Power	+5 V power supply.
VEE	Power	–5 V power supply.
VREG	Input	Regulated Voltage. (See Note 1.) Provides negative power supply for power amplifiers. Connection point for inductor, filter capacitor, and chopper stabilization.
VTX	Output	Transmit Audio. This output is a unity gain version of the A(TIP) and B(RING) metallic voltage. VTX also sources the two-wire input impedance programming network.

**Notes:**

1. All pins, except CHCLK, connect to VBAT when using SLIC without a switching regulator. CHCLK is connected to AGND/DGND.
2. To prevent noise pickup by the detection circuits when using Ground-Key Detect state (E1 = logical 1), a 3300 pF minimum bypass capacitor is recommended between the GKFIL pin and ground.
3. Not available on standard 28-pin DIP package.

**ABSOLUTE MAXIMUM RATINGS**

Storage temperature	−55°C to +150°C
V <sub>CC</sub> with respect to AGND/DGND	−0.4 V to +7.0 V
V <sub>EE</sub> with respect to AGND/DGND	+0.4 V to −7.0 V
V <sub>BAT</sub> with respect to AGND/DGND	+0.4 V to −70 V
<b>Note:</b> Rise time of V <sub>BAT</sub> (dv/dt) must be limited to 27 V/μs or less when Q <sub>BAT</sub> bypass = 0.33 μF.	
BGND with respect to AGND/DGND	+1.0 V to −3.0 V
A(TIP) or B(RING) to BGND:	
Continuous	−70 V to +1.0 V
10 ms (f = 0.1 Hz)	−70 V to +5.0 V
1 μs (f = 0.1 Hz)	−90 V to +10 V
250 ns (f = 0.1 Hz)	−120 V to +15 V
Current from A(TIP) or B(RING)	±150 mA
Voltage on RINGOUT	BGND to 70 V above Q <sub>BAT</sub>
Voltage on TESTOUT	BGND to 70 V above Q <sub>BAT</sub>
Current through relay drivers	60 mA
Voltage on ring-trip inputs (DA and DB)	V <sub>BAT</sub> to 0 V
Current into ring-trip inputs	±10 mA
Peak current into regulator switch (L pin)	150 mA
Switcher transient peak off voltage on L pin	+1.0 V
C4–C1, E1, CHCLK to AGND/DGND	−0.4 V to V <sub>CC</sub> + 0.4 V
Maximum power dissipation, T <sub>A</sub> (see note)	70°C
In 28-pin ceramic DIP package	2.58 W
In 28-pin plastic DIP package	1.4 W
In 32-pin PLCC package	1.74 W

**Note:** Thermal limiting circuitry on chip will shut down the circuit at a junction temperature of about 165°C. The device should never be exposed to this temperature. Operation above 145°C junction temperature may degrade device reliability. See the SLIC Packaging Considerations for more information.

Stresses above those listed under Absolute Maximum Ratings may cause permanent device failure. Functionality at or above these limits is not implied. Exposure to Absolute Maximum Ratings for extended periods may affect device reliability.

**OPERATING RANGES****Commercial (C) Devices**

Ambient temperature	0°C to +70°C*
V <sub>CC</sub>	4.75 V to 5.25 V
V <sub>EE</sub>	−4.75 V to −5.25 V
V <sub>BAT</sub>	−19 V to −58 V◆
AGND/DGND	0 V
BGND with respect to AGND/DGND	−100 mV to +100 mV
Load Resistance on VTX to ground	10 kΩ min

The Operating Ranges define those limits between which the functionality of the device is guaranteed.

\* Functionality of the device from 0°C to +70°C is guaranteed by production testing. Performance from −40°C to +85°C is guaranteed by characterization and periodic sampling of production units.

◆ Can be used without switching regulator components in this range of battery voltages, provided maximum power dissipation specifications are not exceeded.

**ELECTRICAL CHARACTERISTICS**

Description	Test Conditions (See Note 1)	Min	Typ	Max	Unit	Note
Analog (V <sub>TX</sub> ) output impedance		3			Ω	4
Analog (V <sub>TX</sub> ) output offset	0°C to +70°C	-1* -2	-35 -35 -30	+35 +35 +30	mV	4
	-40°C to +85°C	-1* -2	-40 -40 -35	+40 +40 +35		
Analog (RSN) input impedance	300 Hz to 3.4 kHz		1	20	Ω	
Longitudinal impedance at A or B				35		
Overload level	4-wire 2-wire	-2.5		+2.5	Vpk	2
<b>Transmission Performance, 2-Wire Impedance (See Test Circuit D)</b>						
2-wire return loss	300 Hz to 3400 Hz	26			dB	4, 10
<b>Longitudinal Balance (2-Wire and 4-Wire, See Test Circuit C); R<sub>L</sub> = 600 Ω</b>						
Longitudinal to metallic L-T, L-4	200 Hz to 1 kHz normal polarity 0°C to +70°C normal polarity -40°C to +85°C reverse polarity		52 63 58 54		dB	1, 2 1, 2, 4 1, 2
	1 kHz to 3.4 kHz normal polarity 0°C to +70°C normal polarity -40°C to +85°C reverse polarity		52 58 54 54			1, 2 1, 2, 4 1, 2
Longitudinal signal generation 4-L	300 Hz to 800 Hz Reverse polarity	-1* -2	40 40 42			
Longitudinal current capability per wire	Active state OHT state	all* all		28 18	mArms	
<b>Insertion Loss (2- to 4-Wire and 4- to 2-Wire, See Test Circuits A and B) BAT = -48 V, R<sub>LDC</sub> = R<sub>LAC</sub> = 600 Ω; BAT = -24 V, R<sub>LDC</sub> = 300 Ω, R<sub>LAC</sub> = 600 Ω</b>						
Gain accuracy	0 dBm, 1 kHz 0°C to +70°C	-1* -2	-0.15 -0.15 -0.10	+0.15 +0.15 +0.10	dB	— 4 —
	0 dBm, 1 kHz -40°C to +85°C	-1* -2	-0.20 -0.20 -0.15	+0.20 +0.20 +0.15		
Variation with frequency	300 Hz to 3400 Hz Relative to 1 kHz 0°C to +70°C	-1* -2	-0.15 -0.15 -0.10	+0.15 +0.15 +0.10	dB	— — 4
	300 Hz to 3400 Hz Relative to 1 kHz -40°C to +85°C	-1* -2	-0.20 -0.20 -0.15	+0.20 +0.20 +0.15		

**Note:**

\*P.G. = Performance Grade

**ELECTRICAL CHARACTERISTICS (CONTINUED)**

Description	Test Conditions (See Note 1)	Min	Typ	Max	Unit	Note
Gain tracking	0°C to +70°C +7 dBm to -55 dBm Reference: -0 dBm	-0.10		+0.10	dB	
	-40°C to +85°C +7 dBm to -55 dBm Reference: -0 dBm	-0.15		+0.15		4 4 —
<b>Balance Return Signal (4- to 4-Wire, See Test Circuit B)</b> BAT = -48 V, R <sub>LDC</sub> = R <sub>LAC</sub> = 600 Ω; BAT = -24 V, R <sub>LDC</sub> = 300 Ω, R <sub>LAC</sub> = 600 Ω						
Gain accuracy	0 dBm, 1 kHz 0°C to +70°C	-1* -2	-0.15 -0.15 -0.10	+0.15 +0.15 +0.10		— 3 —
	0 dBm, 1 kHz -40°C to +85°C	-1* -2	-0.20 -0.20 -0.15	+0.20 +0.20 +0.15		— 3, 4 3, 4
Variation with frequency	300 Hz to 3400 Hz Relative to 1 kHz 0°C to +70°C		-0.10	+0.10	dB	3
	300 Hz to 3400 Hz Relative to 1 kHz -40°C to +85°C		-0.15	+0.15		3 3 3, 4
Gain tracking	0°C to +70°C +3 dBm to -55 dBm Reference: 0 dBm		-0.10	+0.10		3
	-40°C to +85°C +3 dBm to -55 dBm Reference: 0 dBm		-0.15	-0.15		3, 4
Group delay	f = 1 kHz		5.3		μs	4, 12
<b>Total Harmonic Distortion (2- to 4-Wire and 4- to 2-Wire, See Test Circuits A and B)</b> BAT = -48 V, R <sub>LDC</sub> = R <sub>LAC</sub> = 600 Ω						
Harmonic distortion 300 Hz to 3400 Hz	0 dBm		-64	-50	dB	
	+7 dBm		-55	-40		
<b>Idle Channel Noise</b> BAT = -48 V, R <sub>LDC</sub> = R <sub>LAC</sub> = 600 Ω; BAT = -24 V, R <sub>LDC</sub> = 300 Ω, R <sub>LAC</sub> = 600 Ω						
C-message weighted noise	2-wire, 0°C to +70°C 2-wire, -40°C to +85°C		+7	+10 +12	dBrnC	4 4
	4-wire, 0°C to +70°C 4-wire, -40°C to +85°C		+7	+10 +12		4 4
Psophometric weighted noise	2-wire, 0°C to +70°C 2-wire, -40°C to +85°C		-83	-80 -78	dBmp	— 4
	4-wire, 0°C to +70°C 4-wire, -40°C to +85°C		-83	-80 -78		— 4
<b>Single Frequency Out-of-Band Noise (See Test Circuit E)</b>						
Metallic	4 kHz to 9 kHz 9 kHz to 1 MHz 256 kHz and harmonics**		-76 -76 -63		dBm	4 4, 5, 8 4, 5
	Longitudinal	1 kHz to 15 kHz Above 15 kHz 256 kHz and harmonics**		-70 -85 -57		4 4, 5, 8 4, 5

## ELECTRICAL CHARACTERISTICS (CONTINUED)

Description	Test Conditions (See Note 1)	Min	Typ	Max	Unit	Note
<b>Line Characteristics (See Figures 1a, 1b, 1c)</b>						
Short loops, Active state	Battery = -24 V, $R_{LDC} = 300 \Omega$ Battery = -43 V, $R_{LDC} = 600 \Omega$ Battery = -48 V, $R_{LDC} = 600 \Omega$	32.4	35.0	37.6	mA	4, 9 4 —
Long loops, Active state	Battery = -24 V, $R_{LDC} = 640 \Omega$ Battery = -43 V, $R_{LDC} = 1300 \Omega$ Battery = -48 V, $R_{LDC} = 1900 \Omega$	20.0 23.0 18.0				4, 9 4 —
OHT state	Battery = -24 V, $R_{LDC} = 600 \Omega$ Battery = -48 V, $R_{LDC} = 600 \Omega$	15.5	17.5	19.5		4, 9 —
Loop current	Tip Open state, $R_L = 0$ Disconnect state, $R_L = 0$			1.0		
$I_{LIM}$ (ITip and IRing)	Tip and ring shorted to GND		70	105		
<b>Power Dissipation Battery, Normal Loop Polarity</b>						
On-hook Open Circuit state	Battery = -24 V, w/o switching reg. Battery = -48 V, with switching reg.		30 35	75 100	mW	9 —
On-hook OHT state	Battery = -24 V, w/o switching reg. Battery = -48 V, with switching reg.	100	175 135	225		9 —
On-hook Active state	Battery = -24 V, w/o switching reg. Battery = -48 V, with switching reg.		135 180	225 300		9 —
Off-hook OHT state $R_L = 50 \Omega$	Battery = -24 V, w/o switching reg. Battery = -48 V, with switching reg.		500 400	800 750		9 —
Off-hook Active state $R_L = 50 \Omega$	Battery = -24 V, w/o switching reg. Battery = -48 V, with switching reg.		800 800	1100 1000		9 —
<b>Supply Currents, Battery = -24 V or -48 V</b>						
$V_{CC}$ on-hook supply current	Open Circuit state OHT state Active state		3.0 6.0 7.5	4.5 10.0 12.0	mA	9
$V_{EE}$ on-hook supply current	Open Circuit state OHT state Active state		1.0 2.2 2.7	2.3 3.5 6.0		
$V_{BAT}$ on-hook supply current	Open Circuit state OHT state Active state		0.4 3.0 4.0	1.0 5.0 6.0		

**Note:**

\*\*Applies only when switching regulator is used.

<b>Power Supply Rejection Ratio (<math>V_{RIPPLE} = 50 \text{ mVrms}</math>)</b>						
$V_{CC}$	50 Hz to 3.4 kHz	25	45		dB	6
	3.4 kHz to 50 kHz	22	35			
$V_{EE}$	50 Hz to 3.4 kHz	20	40			
	3.4 kHz to 50 kHz	10	25			
$V_{BAT}$	50 Hz to 3.4 kHz	27	45			
	3.4 kHz to 50 kHz	20	40			
Effective int. resistance	CAS to GND	85	170	255	k $\Omega$	4



## ELECTRICAL CHARACTERISTICS (CONTINUED)

Description	Test Conditions (See Note 1)	Min	Typ	Max	Unit	Note
<b>Off-Hook Detector</b>						
Current threshold	$I_{DET} = 365/R_D$	-20		+20	%	
<b>Ground-Key Detector Thresholds, Active State</b>						
Ground-key resistance threshold	Battery = -24 V, B(RING) to GND	1.0	2.2	4.5	k $\Omega$	9
	Battery = -48 V, B(RING) to GND	2.0	5.0	10.0		—
Ground-key current threshold	B(RING) to GND Midpoint to GND		9 9		mA	7
Effective internal resistance	GKFIL to AGND/DGND	18	36	54	k $\Omega$	4
<b>Ring-Trip Detector Input</b>						
Bias current		-5	-0.05		$\mu$ A	
Offset voltage	Source resistance = 0 to 2 M $\Omega$	-50	0	+50	mV	11
<b>Logic Inputs (C4–C1, E0, E1, and CHCLK)</b>						
Input High voltage		2.0			V	
Input Low voltage				0.8		
Input High current	All inputs except E1	-75		40	$\mu$ A	
Input High current	Input E1	-75		45		
Input Low current		-0.4			mA	
<b>Logic Output (<math>\overline{DET}</math>)</b>						
Output Low voltage	$I_{OUT} = 0.8$ mA			0.4	V	
Output High voltage	$I_{OUT} = -0.1$ mA	2.4				
<b>Relay Driver Outputs (RINGOUT, TESTOUT)</b>						
On voltage	25 mA sink			+1.5	V	
Off leakage	$V_{OH} = +15$ V			100	$\mu$ A	

RELAY DRIVER SCHEMATICS

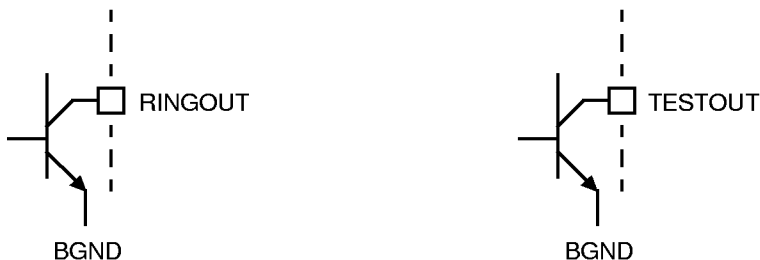

15474A-002

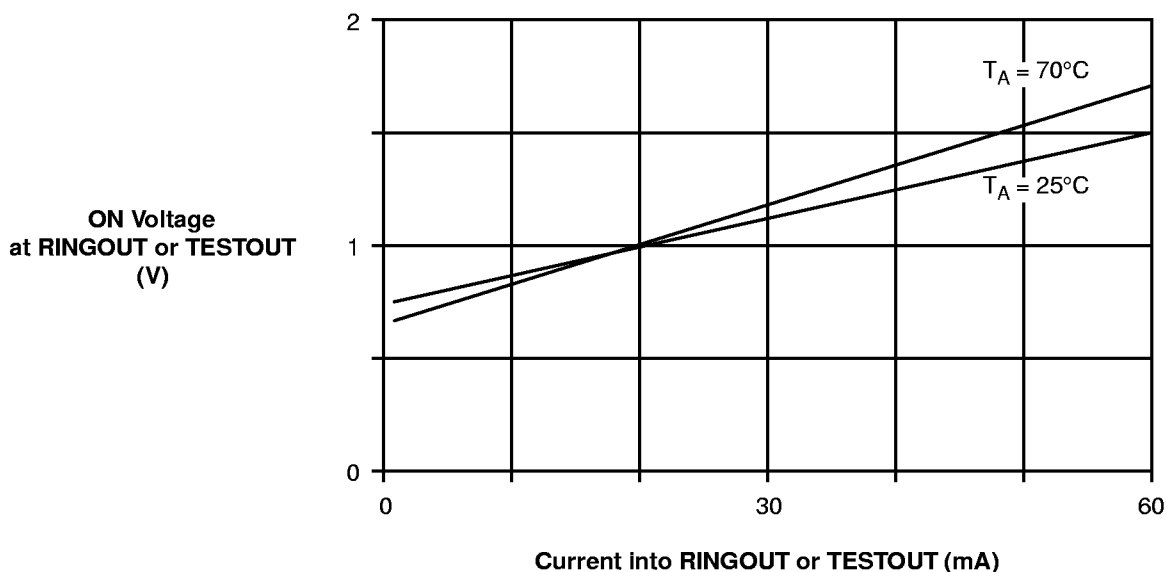

SWITCHING CHARACTERISTICS

Symbol	Parameter	Test Conditions	Temperature Range	Min	Typ	Max	Unit	Note
tgkde	E1 Low to $\overline{\text{DET}}$ High (E0 = 1)	Ground-Key Detect state $R_L$ open, $R_G$ connected (See Figure H)	0°C to +70°C			3.8	$\mu\text{s}$	4
	-40°C to +85°C				4.0			
tshde	E1 Low to $\overline{\text{DET}}$ Low (E0 = 1)	Switchhook Detect state $R_L = 600 \Omega$ , $R_G$ open (See Figure G)	0°C to +70°C			1.1		
	-40°C to +85°C				1.6			
	E1 High to $\overline{\text{DET}}$ Low (E0 = 1)	0°C to +70°C			1.2			
	-40°C to +85°C			1.7				
	E1 High to $\overline{\text{DET}}$ High (E0 = 1)		0°C to +70°C			3.8		
			-40°C to +85°C			4.0		

SWITCHING WAVEFORMS

E1 to  $\overline{\text{DET}}$

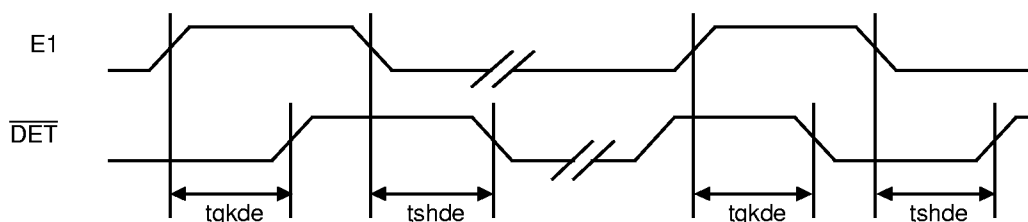

Note:

All delays measured at 1.4 V levels.

15474A-003

**Notes:**

1. Unless otherwise noted, test conditions are  $BAT = -48\text{ V}$ ,  $V_{CC} = +5\text{ V}$ ,  $V_{EE} = -5\text{ V}$ ,  $R_L = 600\ \Omega$ ,  $C_{HP} = 0.33\ \mu\text{F}$ ,  $R_{DC1} = R_{DC2} = 7.14\ \text{k}\Omega$ ,  $C_{DC} = 0.47\ \mu\text{F}$ ,  $R_D = 35.4\ \text{k}\Omega$ ,  $C_{CAS} = 0.47\ \mu\text{F}$ , no fuse resistors,  $R_T = 120\ \text{k}\Omega$ , and  $R_{RX} = 60\ \text{k}\Omega$ . Switching regulator components:  $L = 1\ \text{mH}$ ,  $C_{FIL} = 0.47\ \mu\text{F}$  (see Application Circuit).
2. Overload level is defined when  $THD = 1\%$ .
3. Balance return signal is the signal generated at  $V_{TX}$  by  $V_{RX}$ . This specification assumes the two-wire AC load impedance matches the programmed impedance.
4. Not tested in production. This parameter is guaranteed by characterization or correlation to other tests.
5. For frequencies below 12 kHz, these tests are performed with a longitudinal impedance of 90  $\Omega$  and metallic impedance of 300  $\Omega$ . For frequencies greater than 12 kHz, a longitudinal impedance of 90  $\Omega$  and a metallic impedance of 135  $\Omega$  is used. These tests are extremely sensitive to circuit board layout. Please refer to application notes for details.
6. This parameter is tested at 1 kHz in production. Performance at other frequencies is guaranteed by characterization.
7. "Midpoint" is defined as the connection point between two 300  $\Omega$  series resistors connected between A(TIP) and B(RING).
8. Fundamental and harmonics from 256 kHz switch regulator chopper are not included.
9. For -24 V battery, switching regulator is disabled. L, CHS, and VREG pins connected to VBAT pin; CHCLK pin connected to AGND/DGND.
10. Assumes the following  $Z_T$  network:

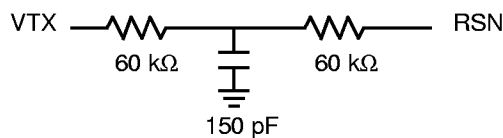

11. Tested with 0  $\Omega$  source impedance. 2 M $\Omega$  is specified for system design purposes only.
12. Group delay can be considerably reduced by using a  $Z_T$  network such as that shown in Note 10 above. The network reduces the group delay to less than 2  $\mu\text{s}$ . The effect of group delay on linecard performance may be compensated for by using the QSLAC™ or DSLAC™ device.

**Table 1. SLIC Decoding**

State	C3 C2 C1	Two-Wire Status	$\overline{\text{DET}}$ Output	
			E1 = 0	E1 = 1
0	0 0 0	Open Circuit	Ring trip	Ring trip
1	0 0 1	Ringing	Ring trip	Ring trip
2	0 1 0	Active	Loop detector	Ground key
3	0 1 1	On-Hook TX (OHT)	Loop detector	Ground key
4	1 0 0	Tip Open	Loop detector	—
5	1 0 1	Reserved	Loop detector	—
6	1 1 0	Active Polarity Reversal	Loop detector	Ground key
7	1 1 1	OHT Polarity Reversal	Loop detector	Ground key

Table 2. User-Programmable Components

$Z_T = 200(Z_{2WIN} - 2R_F^*)$	<p><math>Z_T</math> is connected between the VTX and RSN pins. The fuse resistors are <math>R_F</math>, and <math>Z_{2WIN}</math> is the desired 2-wire AC input impedance. When computing <math>Z_T</math>, the internal current amplifier pole and any external stray capacitance between VTX and RSN must be taken into account.</p>
$Z_{RX} = \frac{Z_L}{G_{42L}} \bullet \frac{200Z_T}{Z_T + 200(Z_L + 2R_F)}$	<p><math>Z_{RX}</math> is connected from <math>V_{RX}</math> to the <math>R_{SN}</math>. <math>Z_T</math> is defined above, and <math>G_{42L}</math> is the desired receive gain.</p>
$R_{DC1} + R_{DC2} = \frac{500}{I_{LOOP}}$ $C_{DC} = 1.5 \text{ ms} \bullet \frac{R_{DC1} + R_{DC2}}{R_{DC1} R_{DC2}}$	<p><math>R_{DC1}</math>, <math>R_{DC2}</math>, and <math>C_{DC}</math> form the network connected to the RDC pin. <math>R_{DC1}</math> and <math>R_{DC2}</math> are approximately equal. <math>I_{LOOP}</math> is the desired loop current in the constant-current region.</p>
$R_D = \frac{365}{I_T}, \quad C_D = \frac{0.5 \text{ ms}}{R_D}$	<p><math>R_D</math> and <math>C_D</math> form the network connected from RD to <math>-5 \text{ V}</math>, and <math>I_T</math> is the threshold current between on hook and off hook.</p>
$C_{CAS} = \frac{1}{3.4 \bullet 10^5 \pi f_c}$	<p><math>C_{CAS}</math> is the regulator filter capacitor, and <math>f_c</math> is the desired filter cut-off frequency.</p>

**Note:**

\* $R_{FUSE} = 20 \Omega - 50 \Omega$ , user selectable.

### DC FEED CHARACTERISTICS

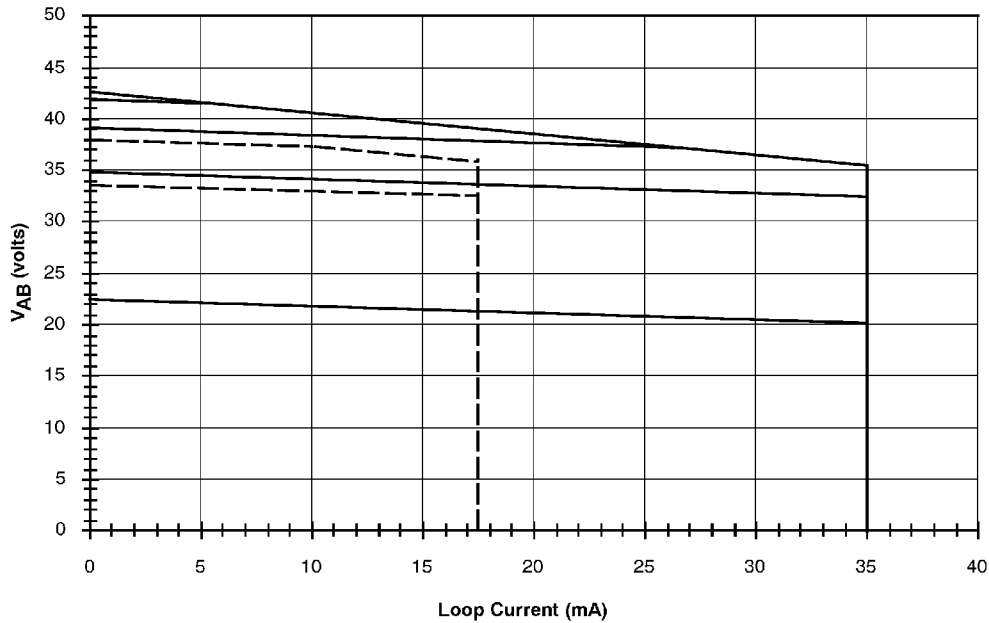

$$R_{DC1} + R_{DC2} = R_{DC} = 14.28 \text{ k}\Omega$$

———— Active state  
 - - - - - OHT state

**Notes:**

1. Constant-current region:

Active state:  $I_L = \frac{500}{R_{DC}}$

OHT state:  $I_L = \frac{250}{R_{DC}}$

2. Anti-saturation turn-on (Active state):

a. Battery independent:  $V_{AB} = 35.5 \text{ V}$ , ( $|V_{BAT}| > 46.2 \text{ V}$ )

b. Battery tracking:  $V_{AB} = 1.1 |V_{BAT}| - 15$ , ( $|V_{BAT}| \geq 46.2 \text{ V}$ )  
 $V_{AB} = 0.7 |V_{BAT}| + 3.5$ , ( $|V_{BAT}| < 46.2 \text{ V}$ )

3. Open circuit voltage:

Active state:  $V_{AB} = 42.6$ , ( $|V_{BAT}| > 53 \text{ V}$ )  
 $V_{AB} = 0.7 |V_{BAT}| + 5.89$ , ( $|V_{BAT}| \leq 53 \text{ V}$ )

OHT state,  $V_{AB} = 39.1$ , ( $|V_{BAT}| > 49.8 \text{ V}$ )  
 $V_{AB} = 0.7 |V_{BAT}| + 4.7$ , ( $|V_{BAT}| \leq 49.8 \text{ V}$ )

4. Anti-saturation 1 region:

Active state:  $V_{AB} = 46.2 - I_L \left( \frac{R_{DC}}{70.4} \right)$

OHT state:  $V_{AB} = 39.1 - I_L \left( \frac{R_{DC}}{70.4} \right)$

5. Anti-saturation 2 region:

Active state:  $V_{AB} = 0.7 |V_{BAT}| + 5.89 - I_L \left( \frac{R_{DC}}{210} \right)$

OHT state:  $V_{AB} = 0.7 |V_{BAT}| + 4.7 - I_L \left( \frac{R_{DC}}{210} \right)$

a.  $V_A - V_B$  ( $V_{AB}$ ) Voltage vs. Loop Current (Typical)

DC FEED CHARACTERISTICS (continued)

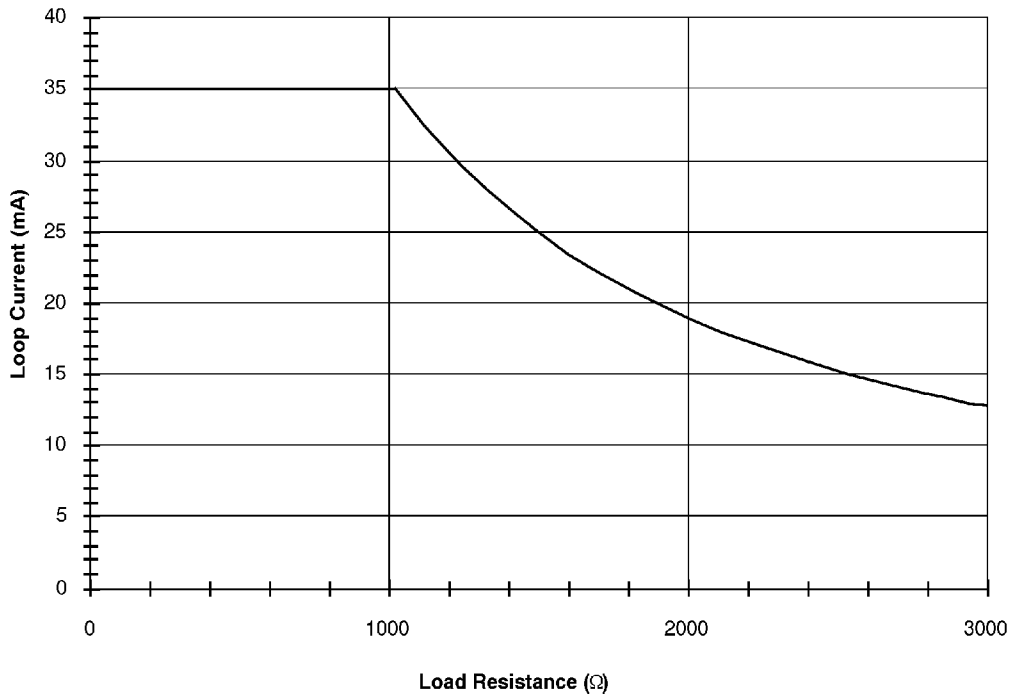

$R_{DC1} + R_{DC2} = R_{DC} = 14.28 \text{ k}\Omega$

$V_{BAT} = 47.3 \text{ V}$

b. Loop Current vs. Load Resistance (Typical)

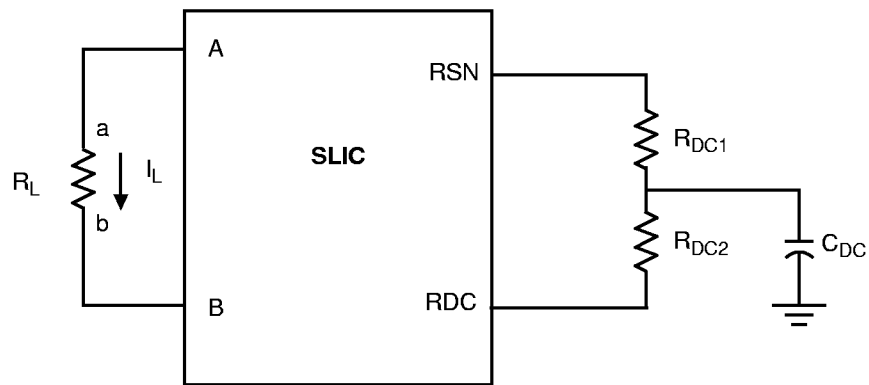

Feed current programmed by  $R_{DC1}$  and  $R_{DC2}$

c. Feed Programming

15474A-004

Figure 1. DC Feed Characteristics

TEST CIRCUITS

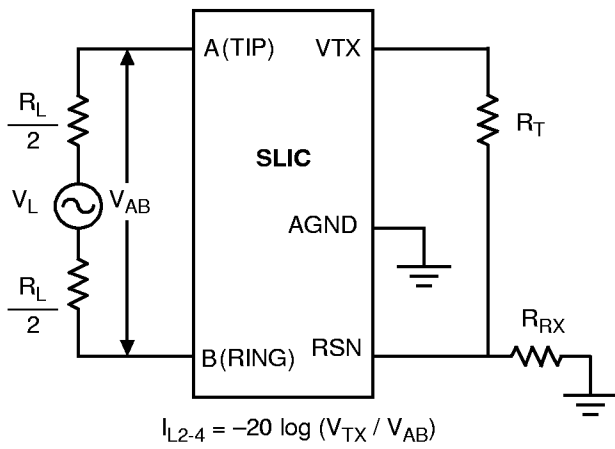

A. Two- to Four-Wire Insertion Loss

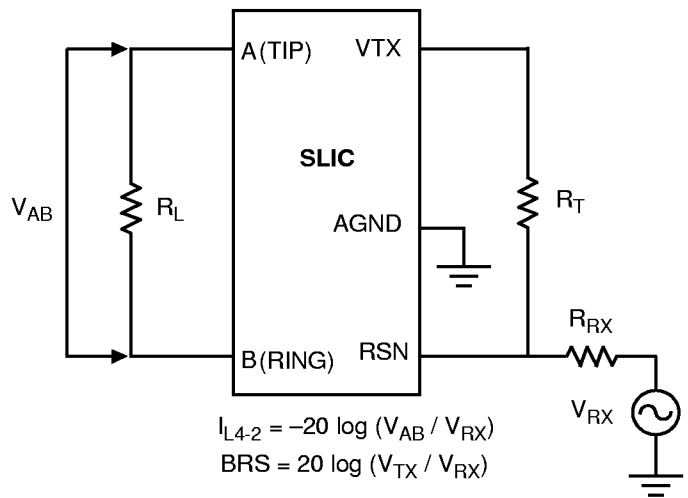

B. Four- to Two-Wire Insertion Loss and Balance Return Signal

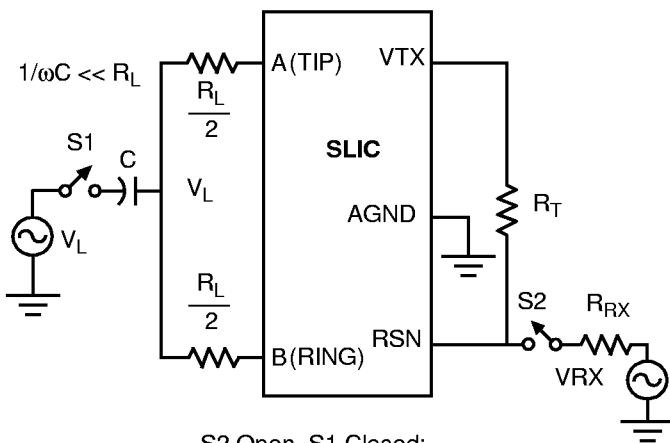

S2 Open, S1 Closed:  
 L-T Long. Bal. =  $20 \log (V_{AB} / V_L)$   
 L-4 Long. Bal. =  $20 \log (V_{TX} / V_L)$   
 S2 Closed, S1 Open:  
 4-L Long. Sig. Gen. =  $20 \log (V_L / V_{RX})$

C. Longitudinal Balance

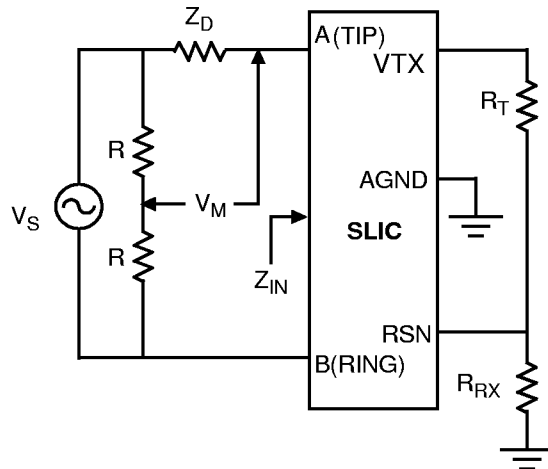

**Note:**  
 $Z_D$  is the desired impedance (e.g., the characteristic impedance of the line).

$$R_L = -20 \log (2 V_M / V_S)$$

D. Two-Wire Return Loss Test Circuit

TEST CIRCUITS (continued)

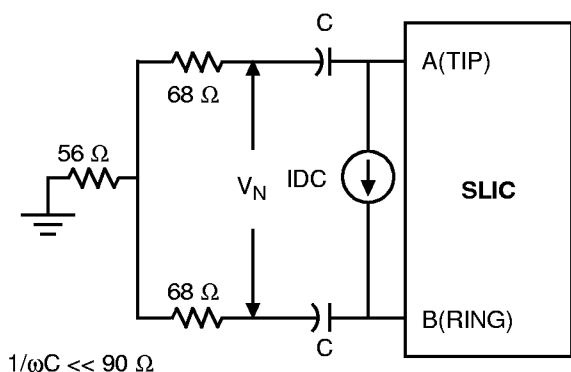

E. Single-Frequency Noise

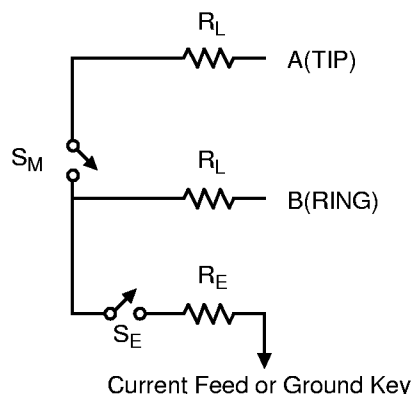

F. Ground-Key Detection Center Point Test

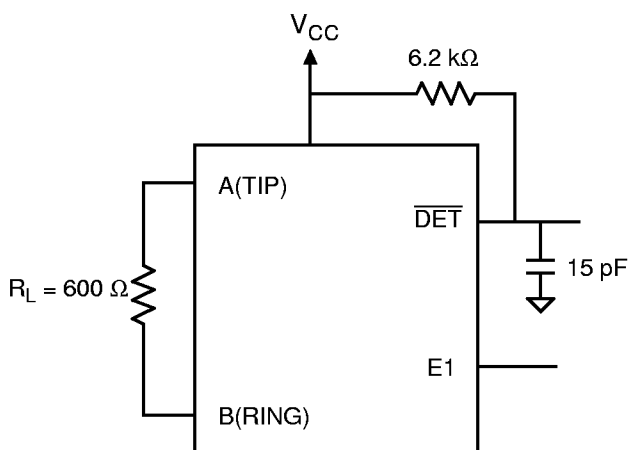

G. Loop-Detector Switching

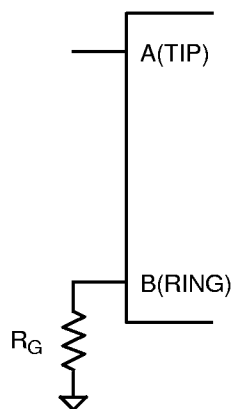

$R_G$ : 2 k $\Omega$  at  $V_{BAT} = -48$  V  
 1 k $\Omega$  at  $V_{BAT} = -24$  V

H. Ground-Key Switching

REVISION SUMMARY

Revision C to Revision D

- Minor changes were made to the data sheet style and format to conform to AMD standards.
- Table 1—Some information in the table was revised, including the addition of the Reserved status.

Revision D to Revision E

- Minor changes were made to the data sheet style and format to conform to AMD standards.
- In Pin Description table, inserted/changed TP pin description to: "Thermal pin. Connection for heat dissipation. Internally connected to substrate (QBAT). Leave as open circuit or connected to QBAT. In both cases, the TP pins can connect to an area of copper on the board to enhance heat dissipation."

Trademarks

Copyright © 1998 Advanced Micro Devices, All rights reserved.

AMD, the AMD logo and combinations thereof are trademarks of Advanced Micro Devices, Inc.

DSLAC and QSLAC are trademarks of Advanced Micro Devices, Inc.

Product names used in this publication are for identification purposes only and may be trademarks of their respective companies.





## Count Registers

Each of the three timers has a 16-bit count register. The contents of this register may be read or written by the processor at any time. If the register is written into while the timer is counting, the new value will take effect in the current count cycle.

The count registers should be programmed before attempting to use the timers, since they are not automatically initialized to zero.

## Max Count Registers

Timers 0 and 1 have two MAX COUNT registers, while Timer 2 has a single MAX COUNT register. These contain the number of events the timer will count. In timers 0 and 1, the MAX COUNT register used can alternate between the two MAX COUNT values whenever the current maximum count is reached. A timer resets when the timer count register equals the MAX COUNT value being used. If the timer count register or the MAX COUNT register is changed so that the MAX COUNT is less than the timer count the timer does not immediately reset. Instead, the timer counts up to 0FFFFH, "wraps around" to zero, counts up to the MAX COUNT value, and then resets.

## Timers and Reset

Upon RESET, the Timers will perform the following actions:

- All EN (Enable) bits are reset preventing timer counting.
- For Timers 0 and 1, the RIU bits are reset to zero and the ALT bits are set to one. This results in the Timer Out pins going High.
- The contents of the count registers are indeterminate.

## INTERRUPT CONTROLLER

The 80C186 can receive interrupts from a number of sources, both internal and external. The internal interrupt controller serves to merge these requests on a priority basis, for individual service by the CPU.

Internal interrupt sources (Timers and DMA channels) can be disabled by their own control registers or by mask bits within the interrupt controller. The 80C186 interrupt controller has its own control register that sets the mode of operation for the controller.

The interrupt controller will resolve priority among requests that are pending simultaneously. Nesting is provided so interrupt service routines for lower priority interrupts may themselves be interrupted by higher priority interrupts. A block diagram of the interrupt controller is shown in Figure 19.

The 80C186 has a special slave mode in which the internal interrupt controller acts as a slave to an external master. The controller is programmed into this mode by setting bit 14 in the peripheral control block relocation register (see Slave Mode section).

## MASTER MODE OPERATION

### Interrupt Controller External Interface

Five pins are provided for external interrupt sources. One of these pins is NMI, the non-maskable interrupt. NMI is generally used for unusual events such as power-fail interrupts. The other four pins may be configured in any of the following ways:

- As four interrupt lines with internally generated interrupt vectors.
- As an interrupt line and interrupt acknowledge line pair (cascade mode) with externally generated interrupt vectors plus two interrupt input lines with internally generated vectors.
- As two pairs of interrupt/interrupt acknowledge lines (cascade mode) with externally generated interrupt vectors.

External sources in the cascade mode use externally generated interrupt vectors. When an interrupt is acknowledged, two  $\overline{INTA}$  cycles are initiated and the vector is read into the 80C186 on the second cycle. The capability to interface to external 82C59A programmable interrupt controllers is provided when the inputs are configured in cascade mode.

### Interrupt Controller Modes of Operation

The basic modes of operation of the interrupt controller in master mode are similar to the 82C59A. The interrupt controller responds identically to internal interrupts in all three modes; the difference is only in the interpretation of function of the four external interrupt pins. The interrupt controller is set into one of these three modes by programming the correct bits in the INT0 and INT1 control registers. The modes of interrupt controller operation are as follows:

#### Fully Nested Mode

When in the fully nested mode four pins are used as direct interrupt requests as in Figure 20. The vectors for these four inputs are generated internally. An in-service bit is provided for every interrupt source. If a lower-priority device requests an interrupt while the in-service bit (IS) is set, no interrupt will be generated by the interrupt controller. In addition, if another interrupt request occurs from the same interrupt source while the in-service bit is set, no interrupt will be generated by the interrupt controller. This allows interrupt service routines to operate

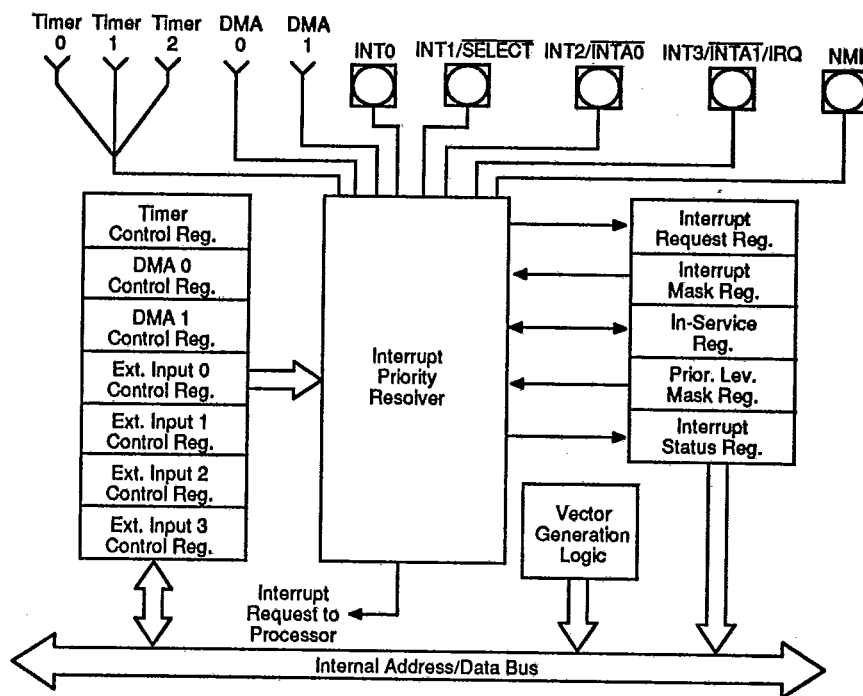

Figure 19. Interrupt Controller Block Diagram

13087D-020

**Master Mode Features**

**Programmable Priority**

The user can program the interrupt sources into any of eight different priority levels. The programming is done by placing a 3-bit priority level (0-7) in the control register of each interrupt source. (A source with a priority level of 4 has higher priority over all priority levels from 5 to 7. Priority registers containing values lower than 4 have greater priority.) All interrupt sources have pre-programmed default priority levels (see Table 3).

If two requests with the same programmed priority level are pending at once, the priority ordering scheme shown in Table 3 is used. If the serviced interrupt routine reenables interrupts, it allows other interrupt requests to be serviced.

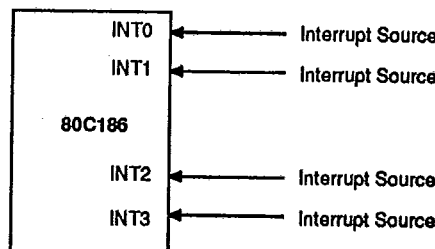

13087D-021

Figure 20. Fully Nested (Direct) Mode Interrupt Controller Connections

SWITCHING CHARACTERISTICS (continued)

T-49-17-15

Ready, Peripheral, and Queue Status Timings

T<sub>A</sub> = 0°C to +70°C, V<sub>CC</sub> = 5 V ± 10% except V<sub>CC</sub> = 5 V ± 5% at f > 12.5 MHz

No	Symbol	Parameter	Preliminary								Unit
			80C186		80C186-12		80C186-16		80C186-20		
			Min	Max	Min	Max	Min	Max	Min	Max	
<b>80C186 Ready and Peripheral Timing Requirements</b>											
47	t <sub>SRVCL</sub>	Synchronous Ready (SRDY) Transition Setup Time <sup>(1)</sup>	15		15		15		10		ns
48	t <sub>CLSRV</sub>	SRDY Transition Hold Time <sup>(1)</sup>	15		15		15		10		ns
49	t <sub>ARYCH</sub>	ARDY Resolution Transition Setup Time <sup>(2)</sup>	15		15		15		10		ns
50	t <sub>CLARK</sub>	ARDY Active Hold Time <sup>(1)</sup>	15		15		15		10		ns
51	t <sub>ARYCHL</sub>	ARDY Inactive Holding Time	15		15		15		10		ns
52	t <sub>ARYLCL</sub>	Asynchronous Ready (ARDY) Setup Time <sup>(1)</sup>	25		25		25		20		ns
53	t <sub>INVCH</sub>	INTx, NMI, TEST/BUSY, TMR IN Setup Time <sup>(2)</sup>	15		15		15		15		ns
54	t <sub>INVCL</sub>	DRQ0, DRQ1, Setup Time <sup>(2)</sup>	15		15		15		15		ns
<b>80C186 Peripheral and Queue Status Timing Responses</b>											
55	t <sub>CLTMV</sub>	Timer Output Delay		40		33		27		25	ns
56	t <sub>CHOSV</sub>	Queue Status Delay		37		32		30		23	ns

All timings are measured at 1.5 V and 100 pF loading on CLKOUT unless otherwise noted. All output test conditions are with C<sub>L</sub> = 50–200 pF (10 MHz) and C<sub>L</sub> = 50–100 pF (12.5–20 MHz). For AC tests, input V<sub>L</sub> = 0.45 V and V<sub>H</sub> = 2.4 V except at X<sub>1</sub> where V<sub>H</sub> = V<sub>CC</sub> - 0.5 V.

- Notes: 1. To guarantee proper operation.
- 2. To guarantee recognition at clock edge.

Synchronous Ready (SRDY) Waveforms

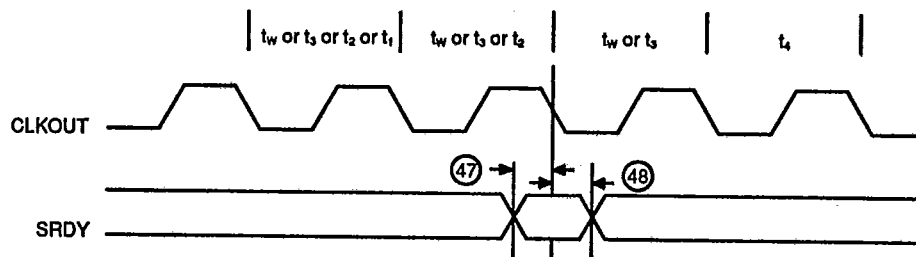



### Asynchronous Ready (ARDY) Waveforms

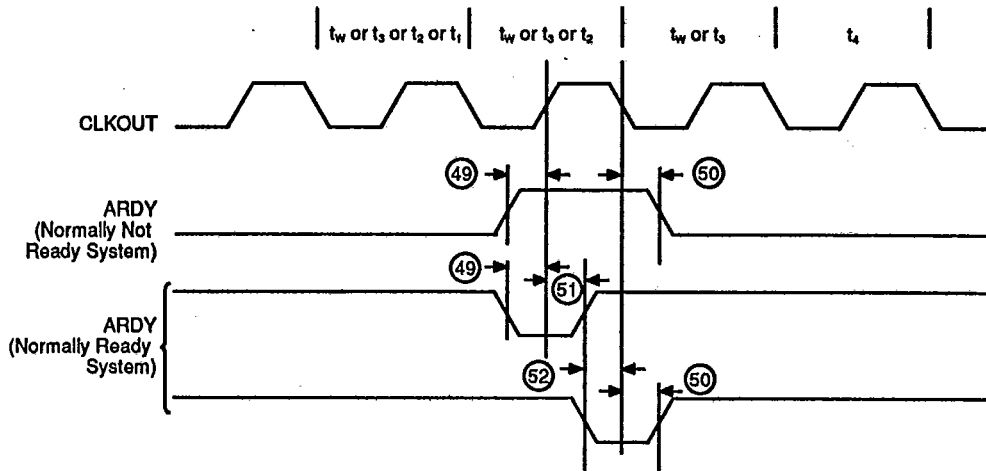

### Peripheral and Queue Status Waveforms

