

TOSHIBA Bipolar Liner Integrated Circuit Silicon Monolithic

TA2136FG, TA2136NG



Sound Retrieval System; 3D Sound IC

The device incorporated the SRS; Sound Retrieval System under license from SRS Labs, Inc.

The TA2136FG/TA2136NG is the IC with the Sound Retrieval System to make 3D sound. It supports both stereo and monaural signal inputs. This allows TA2136FG/TA2136NG to be suitable for various audio systems such as TVs, stereo equipments, radio cassette recorders, video game machines, electronic organs, and PC units.

Features

- Incorporates three mode selectors.
 - (1) Monaural mode (SRS 3D mono)
 - (2) Stereo mode (SRS 3D stereo)
 - (3) Bypass mode (bypass mode)
- Center and space controlling functions
- Wide operation supply voltage
: $V_{CC} (ope.) = 4.5 \text{ to } 12 \text{ V} (T_a = 25^\circ\text{C})$

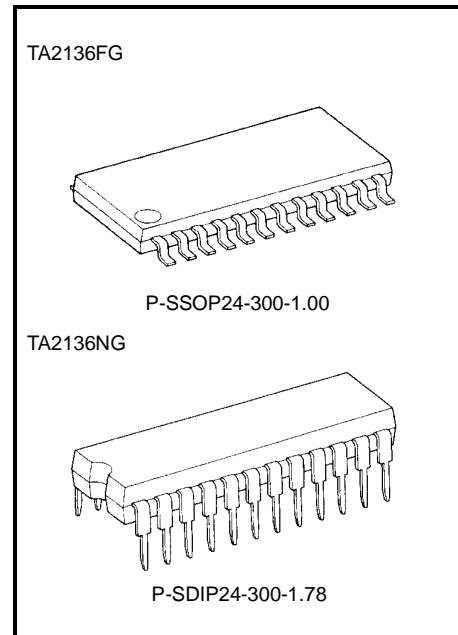

Weight
 P-SSOP24-300-1.00 : 0.31 g (typ.)
 P-SDIP24-300-1.78 : 1.2 g (typ.)

Block Diagram

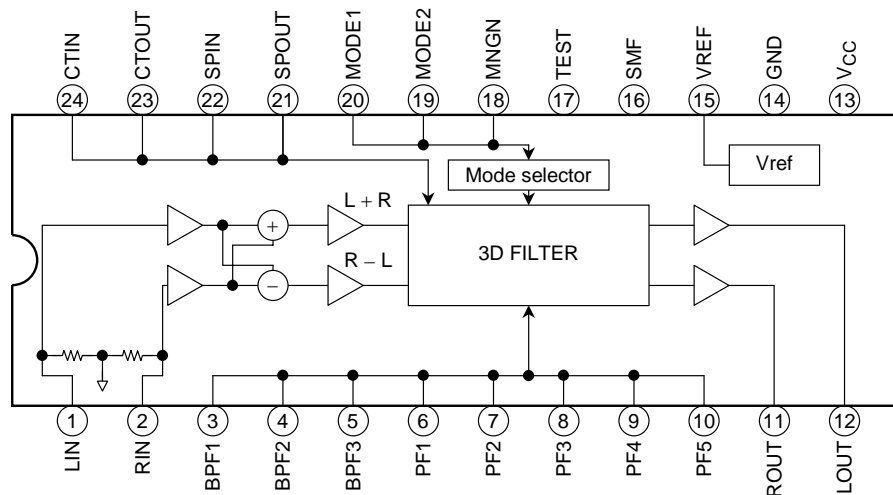

Note 1: This device is vulnerable to surge voltages. Take it into account when using this device in your system.

The SRS; Sound Retrieval System and **SRS** are registered trademarks of SRS Labs, Inc.

Pin Function

Pin No.	Symbol	I/O	Function	Remarks
1	LIN	I	L channel signal input pin.	
2	RIN	I	R channel signal input pin.	
3	BPF1	—	BPF1 pin for band pass filter.	
4	BPF2	—	BPF2 pin for band pass filter.	
5	BPF3	—	BPF3 pin for band pass filter.	
6	PF1	—	PF1 pin for 3D filter.	
7	PF2	—	PF2 pin for 3D filter.	
8	PF3	—	PF3 pin for 3D filter.	
9	PF4	—	PF4 pin for 3D filter.	
10	PF5	—	PF5 pin for 3D filter.	
11	ROUT	O	R channel signal output pin.	
12	LOUT	O	L channel signal output pin.	
13	V _{CC}	—	Power supply pin.	
14	GND	—	Ground pin.	
15	VREF	I	Reference voltage pin.	
16	SMF	—	SMF pin for smoothing filter.	
17	TEST	I	Test pin, normally fixed "L" level.	
18	MNGN	I	MNGN pin for monoral signal input gain selector. Normally fixed "L" level.	
19	MODE2	I	MODE2 pin for mode selector.	
20	MODE1	I	MODE1 pin for mode selector.	
21	SPOUT	O	Output pin for space control.	
22	SPIN	I	Input pin for space control.	
23	CTOUT	O	Output pin for center control.	
24	CTIN	I	Input pin for center control.	

Application Circuit

www.datasheet4u.com

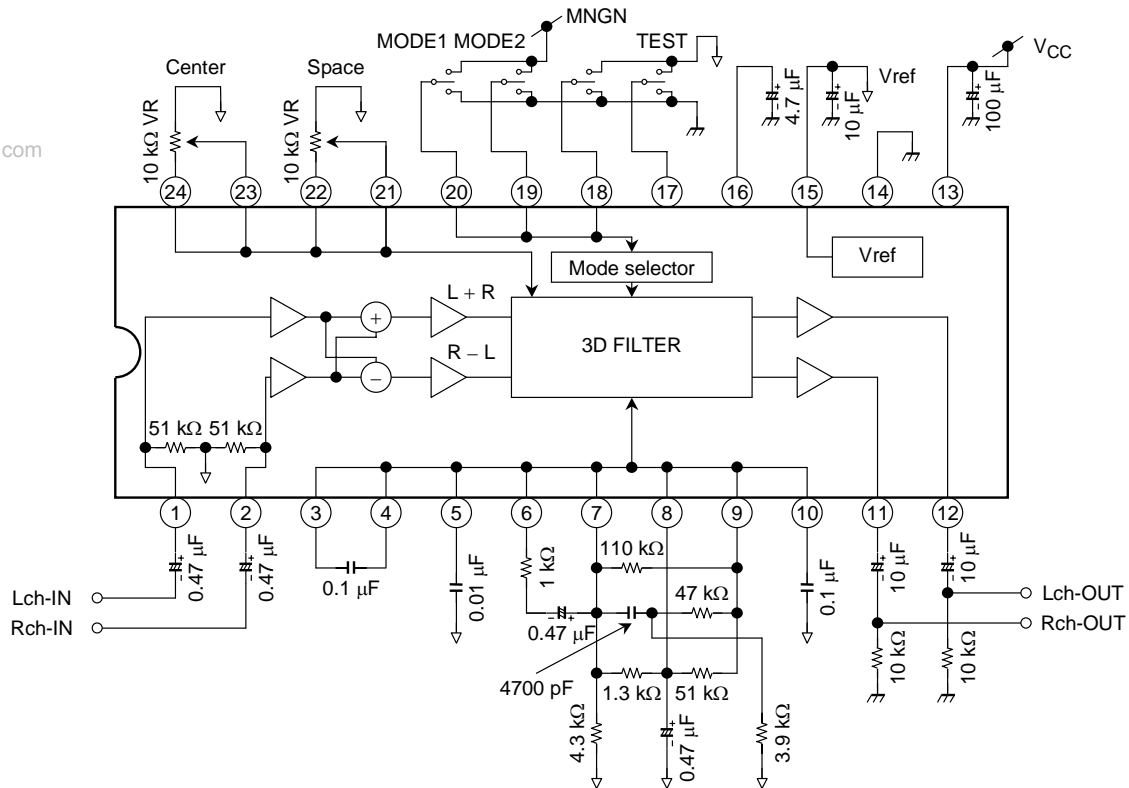

Mode	Mode1	Mode2
Bypass	L	—
3D mono	H	L
3D stereo	H	H

Level	Test (Note 2)	MNGN (Note 3)
L	-3dB	0dB
H	0dB	-6dB

Note 2: Usually, it is used by fixing to "L" level.

Note 3: Usually, it is not concerned with an L channel input or L and R channel input, but is used by fixing to "L" level.

Note 4: The Sound Retrieval System (SRS) technology rights incorporated in the TA2136FG/NG are owned by SRS Labs, a US Corporation and licensed to Toshiba Semiconductor. The Sound Retrieval System (SRS) is protected under US and foreign patents used and/or pending. The Sound Retrieval System (SRS), the  and SRS symbol, are trademarks of SRS Labs, Inc. in the United States and selected foreign countries. Neither the purchase of the TA2136FG/NG, nor the corresponding sale of audio enhancement equipment conveys the right to sell commercialized recordings made with any SRS technology. SRS Labs requires that all users of the TA2136FG/NG must enter into a license agreement directly with SRS Labs and comply with all rules and regulations as outlined in the SRS Trademark Usage Manual.

Absolute Maximum Ratings (Ta = 25°C)

Characteristics	Symbol	Rating	Unit
Supply voltage	V _{CC}	12	V
Power dissipation	P _d	TA2136FG (Note 5)	*400
		TA2136NG (Note 6)	*1200
Operating temperature	T _{opr}	-40 to 85	°C
Storage temperature	T _{stg}	-55 to 150	°C

Note 5: Derated above 25°C in the proportion of 3.2 mW/°C

Note 6: Derated above 25°C in the proportion of 9.6 mW/°C

Electrical Characteristics

(unless otherwise specified, V_{CC} = 9 V, f = 1 kHz, R_L = 10 kΩ, V_{in} = -10dBV, R_g = 600 Ω, bypass mode, Ta = 25°C)

Characteristics	Symbol	Test Circuit	Test Condition	Min	Typ.	Max	Unit
Supply voltage	V _{CC}	—	V _{in} = 0	4.5	9	12	V
Supply current	I _{ccq} (BYP)	—	V _{in} = 0	—	4	7	mA
	I _{ccq} (SRS)	—	V _{in} = 0, SRS STEREO	—	8	14	
	I _{ccq} (MONO)	—	V _{in} = 0, SRS MONO	—	8	14	
Input resistance	R _{in}	—	—	40	50	60	kΩ
Output clipping voltage	V _{OCL}	—	THD = 1%	1.4	1.7	—	V _{rms}
Total harmonic distortion	THD (SRS)	—	SRS STEREO, Space&Center: max	—	0.15	—	%
	THD (MONO)	—	SRS MONO	—	0.2	—	
	THD (BYP)	—	SRS BYPASS, TEST = "H"	—	0.004	—	
Bypass gain	G _V (BYP)	—	—	-5	-3	-1	dB
Output noise voltage	V _{ON} (SRS)	—	Input = GND, Space&Center: MID BW = 20 Hz to 20 kHz	—	35	50	μV _{rms}
Mode select control voltage	V _{CH}	—	High level	2	—	V _{CC}	V
	V _{CL}	—	Low level	GND	—	1	

<Mode Select>

Mode	Mode1	Mode2
Bypass	L	—
3D stereo	H	H
3D mono	H	L

Package Dimensions

P-SSOP24-300-1.00

Unit : mm

www.datasheet4u.com

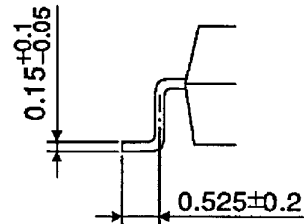
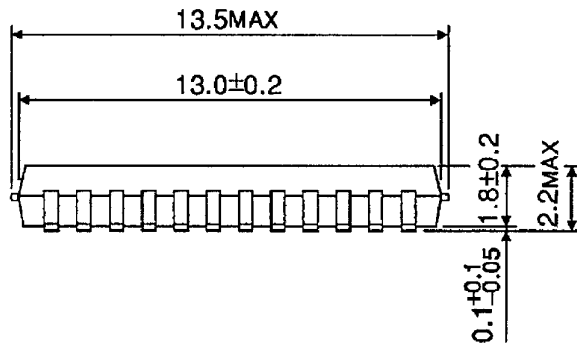
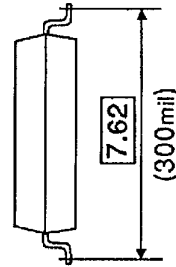
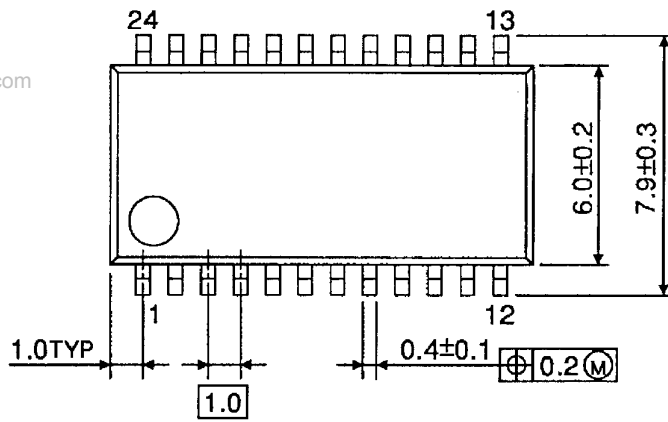

(Note) Sn-Ag plate

Weight: 0.31 g (typ.)

Package Dimensions

SDIP24-P-300-1.78

Unit : mm

www.datasheet4u.com

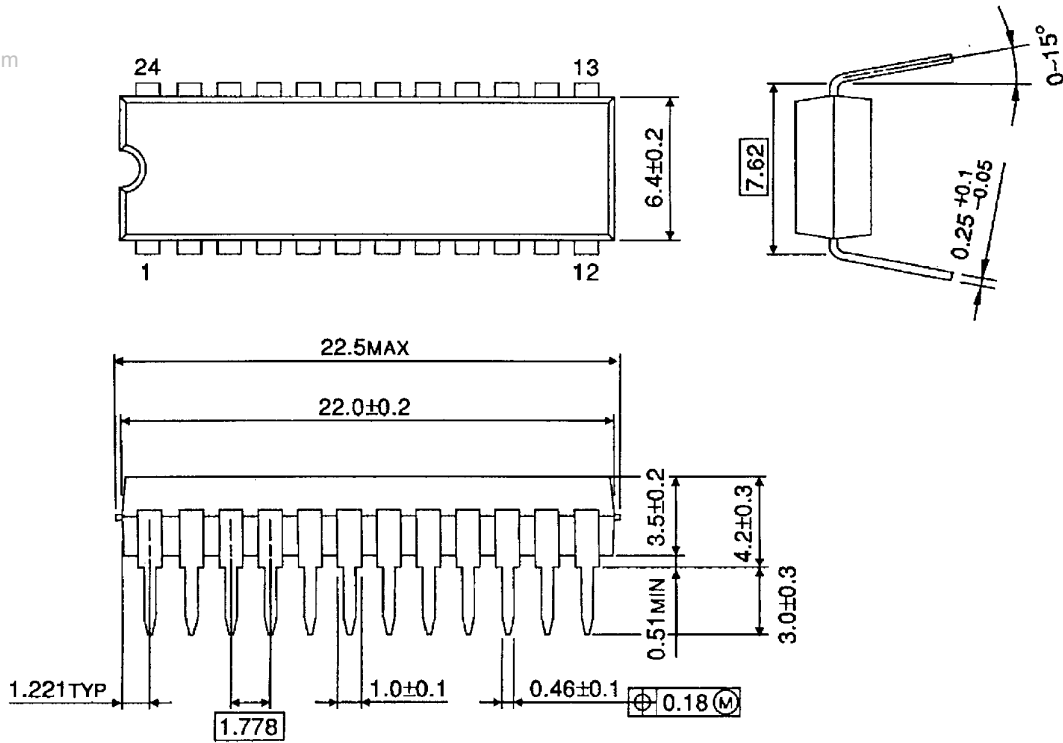

(Note) Sn-Ag plate

Weight: 1.2 g (typ.)

- The information contained herein is subject to change without notice. 021023_D
- TOSHIBA is continually working to improve the quality and reliability of its products. Nevertheless, semiconductor devices in general can malfunction or fail due to their inherent electrical sensitivity and vulnerability to physical stress. It is the responsibility of the buyer, when utilizing TOSHIBA products, to comply with the standards of safety in making a safe design for the entire system, and to avoid situations in which a malfunction or failure of such TOSHIBA products could cause loss of human life, bodily injury or damage to property.
In developing your designs, please ensure that TOSHIBA products are used within specified operating ranges as set forth in the most recent TOSHIBA products specifications. Also, please keep in mind the precautions and conditions set forth in the "Handling Guide for Semiconductor Devices," or "TOSHIBA Semiconductor Reliability Handbook" etc. 021023_A
- The TOSHIBA products listed in this document are intended for usage in general electronics applications (computer, personal equipment, office equipment, measuring equipment, industrial robotics, domestic appliances, etc.). These TOSHIBA products are neither intended nor warranted for usage in equipment that requires extraordinarily high quality and/or reliability or a malfunction or failure of which may cause loss of human life or bodily injury ("Unintended Usage"). Unintended Usage include atomic energy control instruments, airplane or spaceship instruments, transportation instruments, traffic signal instruments, combustion control instruments, medical instruments, all types of safety devices, etc. Unintended Usage of TOSHIBA products listed in this document shall be made at the customer's own risk. 021023_B
- The products described in this document shall not be used or embedded to any downstream products of which manufacture, use and/or sale are prohibited under any applicable laws and regulations. 060106_Q
- The information contained herein is presented only as a guide for the applications of our products. No responsibility is assumed by TOSHIBA for any infringements of patents or other rights of the third parties which may result from its use. No license is granted by implication or otherwise under any patent or patent rights of TOSHIBA or others. 021023_C
- The products described in this document are subject to the foreign exchange and foreign trade laws. 021023_E

About solderability, following conditions were confirmed

- Solderability
 - (1) Use of Sn-37Pb solder Bath
 - solder bath temperature = 230°C
 - dipping time = 5 seconds
 - the number of times = once
 - use of R-type flux
 - (2) Use of Sn-3.0Ag-0.5Cu solder Bath
 - solder bath temperature = 245°C
 - dipping time = 5 seconds
 - the number of times = once
 - use of R-type flux