



3 Ω, High Bandwidth, Dual SPDT Analog Switch

DESCRIPTION

The DG2517/DG2518 are low-voltage dual single-pole/double-throw monolithic CMOS analog switches. Designed to operate from 1.8 V to 5.5 V power supply, the DG2517/DG2518 achieves a bandwidth of 157 MHz while providing low on-resistance (3 Ω), excellent on-resistance matching (0.2 Ω) and flatness (1 Ω) over the entire signal range.

The DG2517/DG2518 offers the advantage of high linearity that reduces signal distortion, making ideal for audio, video, and USB signal routing applications. Additionally, the DG2517/DG2518 are 1.6 V logic compatible within the full operation voltage range.

Built on Vishay Siliconix's proprietary sub-micron high-density process, the DG2517/DG2518 brings low power consumption at the same time as reduces PCB spacing with the MSOP10 and DFN10 packages.

As a committed partner to the community and the environment, Vishay Siliconix manufactures this product with the lead (Pb)-free device terminations. The DFN package has a nickel-palladium-gold device termination and is represented by the lead (Pb)-free "-E4" suffix. The MSOP package uses 100 % matte Tin device termination and is represented by the lead (Pb)-free "-E3" suffix. Both the matte Tin and nickel-palladium-gold device terminations meet all JEDEC standards for reflow and MSL ratings.

FEATURES

- 1.8 to 5.5 V Single Supply Operation
- Low Ron: 3 Ω at 4.2 V
- 157 MHz, - 3 dB Bandwidth
- Low Off-Isolation, - 47 dB at 10 MHz
- + 1.6 V Logic Compatible

BENEFITS

- High Linearity
- Low Power Consumption
- High Bandwidth
- Full Rail Signal Swing Range

APPLICATIONS

- USB/UART Signal Switching
- Audio/Video Switching
- Cellular Phone
- Media Players
- Modems
- Hard Drives
- PCMCIA



RoHS
COMPLIANT

FUNCTIONAL BLOCK DIAGRAM AND PIN CONFIGURATION

DG2517

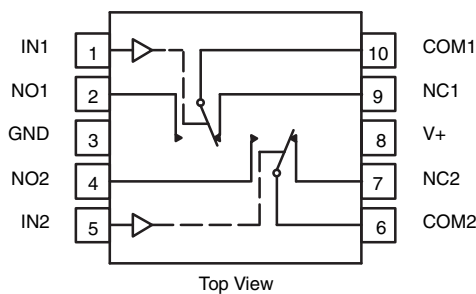

DG2518

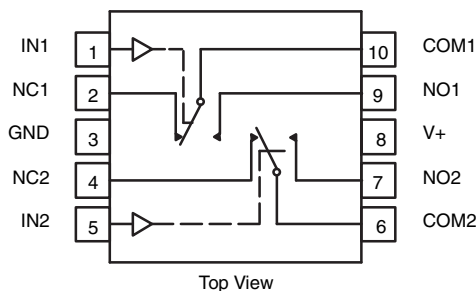

TRUTH TABLE		
Logic	NC1 and NC2	NO1 and NO2
0	ON	OFF
1	OFF	ON

ORDERING INFORMATION		
Temp Range	Package	Part Number
- 40 to 85 °C	MSOP-10	DG2517DQ-T1-E3
		DG2518DQ-T1-E3
	DFN-10	DG2517DN-T1-E4
		DG2518DN-T1-E4



ABSOLUTE MAXIMUM RATINGS			
Parameter	Limit	Unit	
Reference to GND			
V+	- 0.3 to + 6	V	
IN, COM, NC, NO ^a	- 0.3 to (V+ + 0.3)		
Continuous Current (Any terminal)	± 50	mA	
Peak Current (Pulsed at 1 ms, 10 % duty cycle)	± 200		
Storage Temperature (D Suffix)	- 65 to 150	°C	
Power Dissipation (Packages) ^b	MSOP-10 ^c	320	mW
	DFN-10 ^d	1191	

Notes:

- a. Signals on NC, NO, or COM or IN exceeding V+ will be clamped by internal diodes. Limit forward diode current to maximum current ratings.
- b. All leads welded or soldered to PC Board.
- c. Derate 4.0 mW/°C above 70 °C.
- d. Derate 14.9 mW/°C above 70 °C.

SPECIFICATIONS (V+ = 3 V)							
Parameter	Symbol	Test Conditions Otherwise Unless Specified V+ = 3 V, ± 10 %, V _{IN} = 0.5 or 1.4 V ^e	Temp ^a	Limits - 40 to 85 °C			Unit
				Min ^b	Typ ^c	Max ^b	
Analog Switch							
Analog Signal Range ^d	V _{NO} , V _{NC} , V _{COM}		Full	0		V+	V
On-Resistance	r _{ON}	V+ = 2.7 V, V _{COM} = 1.5 V I _{NO/NC} = 10 mA	Room Full		3.2	4.5 5.0	Ω
r _{ON} Flatness	r _{ON} Flatness	V+ = 2.7 V, V _{COM} = 1.5, 2 V I _{NO/NC} = 10 mA	Room Full		1.0	1.4 16	
r _{ON} Match Between Channels	Δr _{ON}	V+ = 2.7 V, V _{COM} = 1.5 V I _{NO/NC} = 10 mA	Room Full		0.1	0.3 0.4	
Switch Off Leakage Current ^f	I _{NO(off)} , I _{NC(off)}	V+ = 3.6 V, V _{NO} , V _{NC} = 0.3 V/ 3 V V _{COM} = 3 V/0.3 V	Room Full	- 1 - 10		1 10	nA
	I _{COM(off)}		Room Full	- 1 - 10		1 10	
Channel-On Leakage Current ^f	I _{COM(on)}	V+ = 3.6 V, V _{NO} , V _{NC} = V _{COM} = 0.3 V/3 V	Room Full	- 1 - 10		1 10	
Digital Control							
Input High Voltage ^d	V _{INH}		Full	1.4			V
Input Low Voltage	V _{INL}		Full			0.5	
Input Capacitance	C _{in}		Full		4		pF
Input Current	I _{INL} or I _{INH}		Full	1		1	μA
Dynamic Characteristics							
Turn-On Time	t _{ON}	V+ = 2.7 V, V _{NO} or V _{NC} = 1.5 V R _L = 300 Ω, C _L = 35 pF	Room Full		15	30 50	ns
Turn-Off Time	t _{OFF}		Room Full		10	25 35	
Break-Before-Make Time	t _d	V _{NO} or V _{NC} = 1.5 V, R _L = 300 Ω, C _L = 35 pF	Full	1			
Charge Injection ^d	Q _{INJ}	C _L = 1 nF, V _{GEN} = 1.5 V, R _{GEN} = 0 Ω	Room		1		pC
- 3 dB Bandwidth	BW	0 dBm, C _L = 5 pF, R _L = 50 Ω	Room		157		MHz
Off-Isolation ^d	OIRR	R _L = 50 Ω, C _L = 5 pF	f = 1 MHz	Room		- 67	dB
			f = 10 MHz	Room		- 47	
Crosstalk ^d	X _{TALK}	R _L = 50 Ω, C _L = 5 pF	f = 1 MHz	Room		- 67	
			f = 10 MHz	Room		- 47	
N _O , N _C Off Capacitance ^d	C _{NO(off)}	V _{IN} = 0 or V+, f = 1 MHz	Room		8		pF
	C _{NC(off)}		Room		8		
Channel-On Capacitance ^d	C _{NO(on)}		Room		35		
	C _{NC(on)}		Room		35		
Power Supply							
Power Supply Current	I+	V _{IN} = 0 or V+	Full		0.01	1.0	μA

Notes:

- a. Room = 25 °C, Full = as determined by the operating suffix.
- b. Typical values are for design aid only, not guaranteed nor subject to production testing.
- c. The algebraic convention whereby the most negative value is a minimum and the most positive a maximum, is used in this data sheet.
- d. Guarantee by design, not subjected to production test.
- e. V_{IN} = input voltage to perform proper function.
- f. Guaranteed by 5 V leakage testing, not production tested.



SPECIFICATIONS (V+ = 5 V)									
Parameter	Symbol	Test Conditions Otherwise Unless Specified V+ = 5 V, ± 10 %, VIN = 0.8 or 2.0 V ^e	Temp ^a	Limits - 40 to 85 °C			Unit		
				Min ^b	Typ ^c	Max ^b			
Analog Switch									
Analog Signal Range ^d	V _{NO} , V _{NC} , V _{COM}		Full	0		V+	V		
On-Resistance	r _{ON}	V+ = 4.2 V, V _{COM} = 3.5 V, I _{NO/NC} = 10 mA	Room Full		3	4.0 4.3	Ω		
r _{ON} Flatness	r _{ON} Flatness	V+ = 4.2 V, V _{COM} = 1, 2, 3.5 V I _{NO/NC} = 10 mA	Room Full		1.1	1.4 1.6			
r _{ON} Match Between Channels	Δr _{ON}	V+ = 4.2 V, V _{COM} = 3.5 V, I _{NO/NC} = 10 mA	Room Full		0.1	0.3 0.4			
Switch Off Leakage Current	I _{NO(off)} , I _{NC(off)}	V+ = 5.5 V V _{NO} , V _{NC} = 1 V/4.5 V, V _{COM} = 4.5 V/1 V	Room Full	- 1 - 10		1 10	nA		
	I _{COM(off)}		Room Full	- 1 - 10		1 10			
Channel-On Leakage Current	I _{COM(on)}	V+ = 5.5 V, V _{COM} = V _{NO} , V _{NC} = 1 V/4.5 V	Room Full	- 1 - 10		1 10			
Digital Control									
Input High Voltage ^d	V _{INH}		Full	2.0			V		
Input Low Voltage	V _{INL}		Full			0.8			
Input Capacitance	C _{in}		Full		4		pF		
Input Current	I _{INL} or I _{INH}	V _{IN} = 0 V or V+	Full	1		1	μA		
Dynamic Characteristics									
Turn-On Time	t _{ON}	V+ = 4.2 V, V _{NO} or V _{NC} = 3 V R _L = 300 Ω, C _L = 35 pF	Room Full		12	25 45	ns		
Turn-Off Time	t _{OFF}		Room Full		8	20 30			
Break-Before-Make Time	t _d	V _{NO} or V _{NC} = 3 V, R _L = 300 Ω, C _L = 35 pF	Full	1					
Charge Injection ^d	Q _{INJ}	C _L = 1 nF, V _{GEN} = 2.5 V, R _{GEN} = 0 Ω	Room		2		pC		
- 3 dB Bandwidth	BW	0 dBm, C _L = 5 pF, R _L = 50 Ω	Room		157		MHz		
Off-Isolation ^d	OIRR	R _L = 50 Ω, C _L = 5 pF	f = 1 MHz	Room		- 67	dB		
			f = 10 MHz	Room		- 47			
Crosstalk ^d	X _{TALK}	R _L = 50 Ω, C _L = 5 pF	f = 1 MHz	Room		- 67			
			f = 10 MHz	Room		- 47			
Source-Off Capacitance ^d	C _{NO(off)}	V _{IN} = 0 or V+, f = 1 MHz	Room		8		pF		
	C _{NC(off)}		Room		8				
Channel-On Capacitance ^d	C _{NO(on)}		Room		35				
	C _{NC(on)}		Room		35				
Power Supply									
Power Supply Range	V+				1.8			5.5	V
Power Supply Current	I+	V _{IN} = 0 or V+	Full		0.01	1.0	μA		

Notes:

- a. Room = 25 °C, Full = as determined by the operating suffix.
- b. Typical values are for design aid only, not guaranteed nor subject to production testing.
- c. The algebraic convention whereby the most negative value is a minimum and the most positive a maximum, is used in this data sheet.
- d. Guarantee by design, nor subjected to production test.
- e. V_{IN} = input voltage to perform proper function.
- f. Guaranteed by 5 V leakage testing, not production tested.

Stresses beyond those listed under "Absolute Maximum Ratings" may cause permanent damage to the device. These are stress ratings only, and functional operation of the device at these or any other conditions beyond those indicated in the operational sections of the specifications is not implied. Exposure to absolute maximum rating conditions for extended periods may affect device reliability.

TYPICAL CHARACTERISTICS 25 °C, unless noted

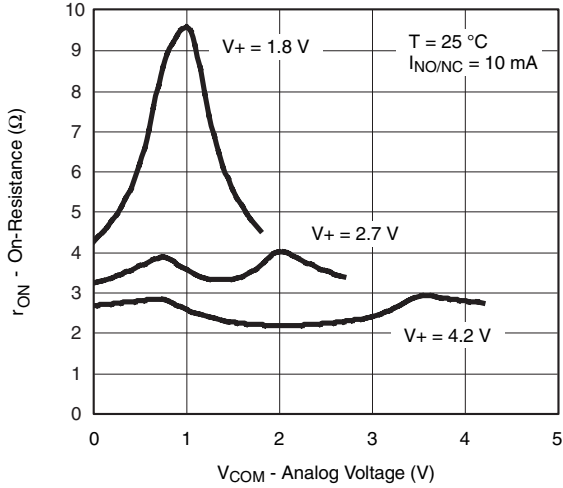

r_{ON} vs. V_{COM} and Supply Voltage

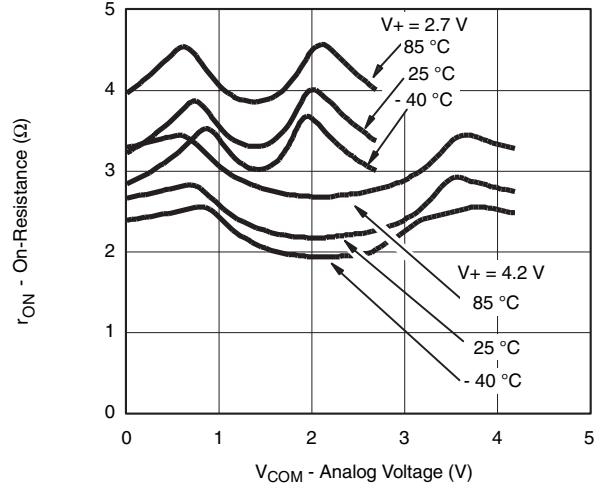

r_{ON} vs. Analog Voltage and Temperature

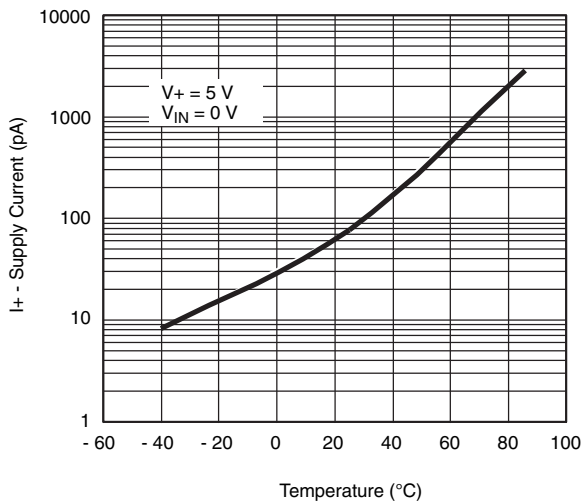

Supply Current vs. Temperature

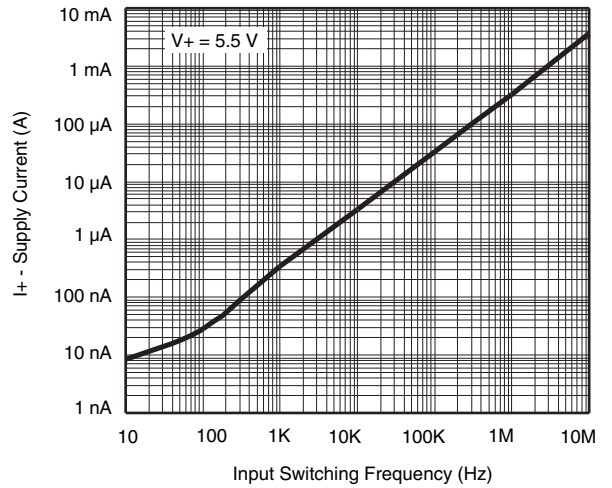

Supply Current vs. Input Switching Frequency

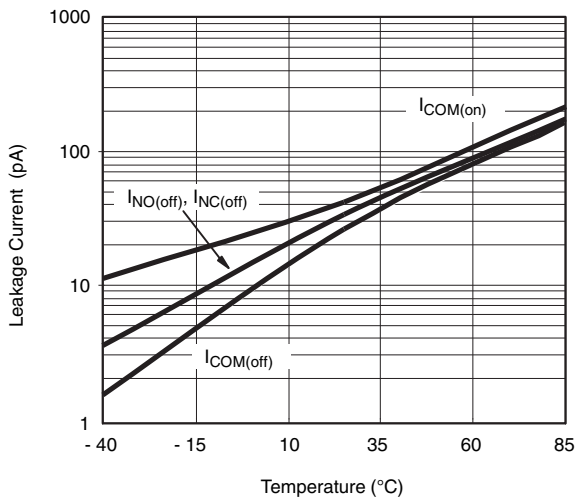

Leakage Current vs. Temperature

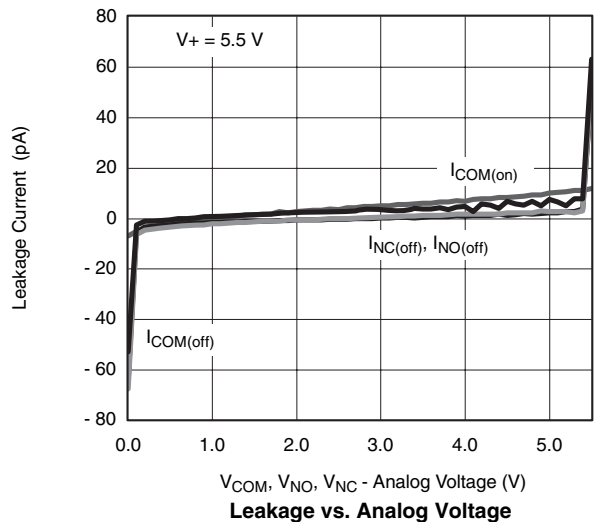

Leakage vs. Analog Voltage

TYPICAL CHARACTERISTICS 25 °C, unless noted

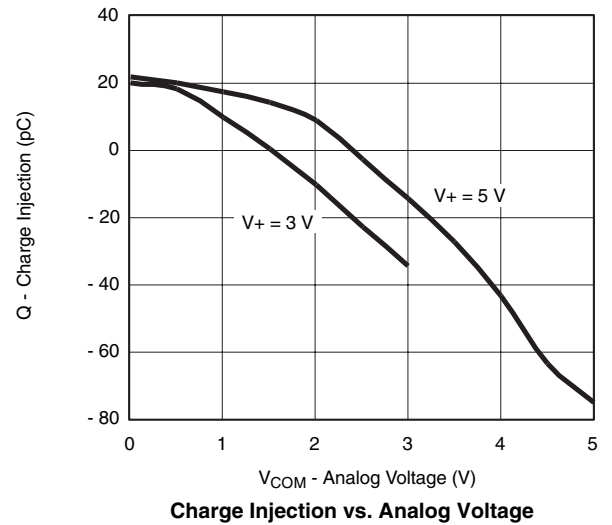
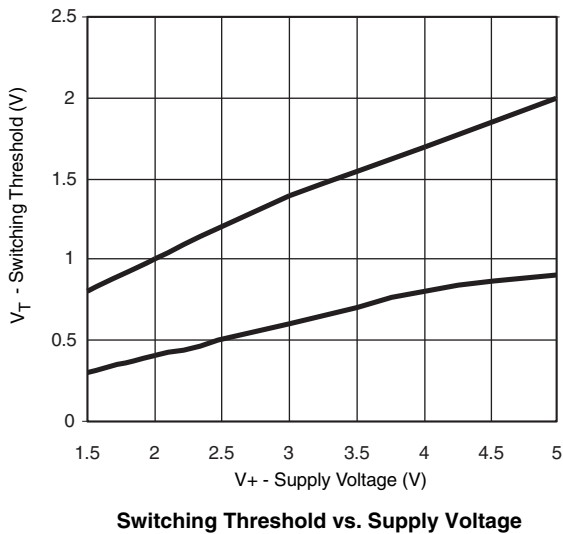
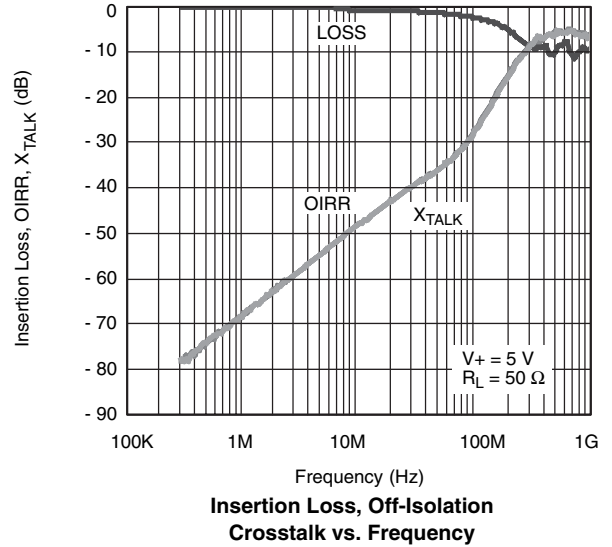
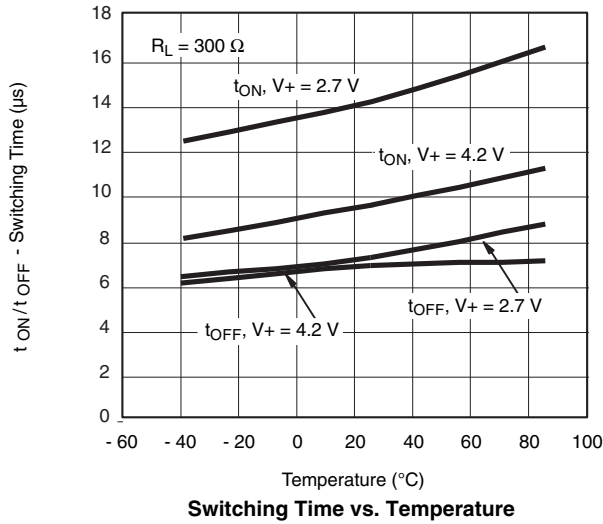

TEST CIRCUITS

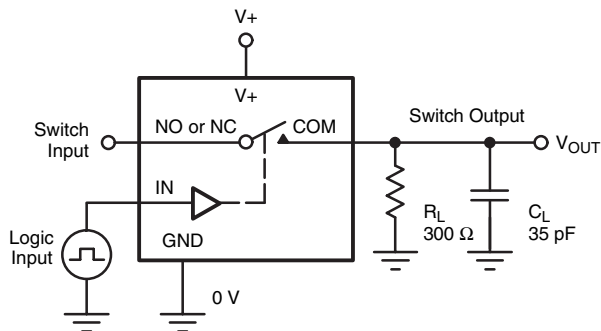

C_L (includes fixture and stray capacitance)

$$V_{OUT} = V_{COM} \left(\frac{R_L}{R_L + R_{ON}} \right)$$

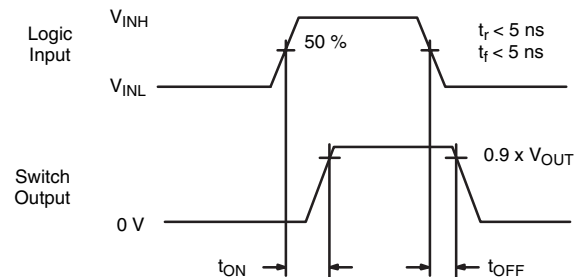

Logic "1" = Switch On
Logic input waveforms inverted for switches that have the opposite logic sense.

Figure 1. Switching Time

TEST CIRCUITS

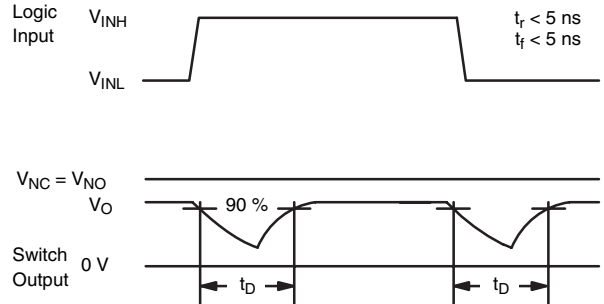
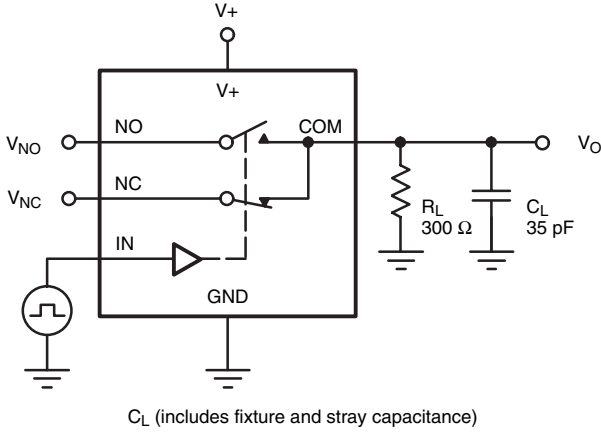
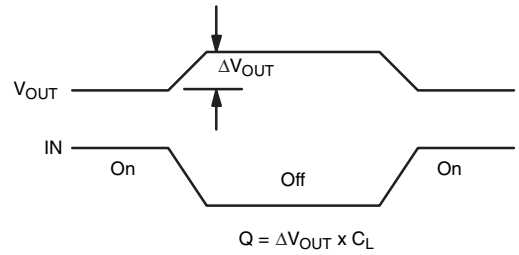
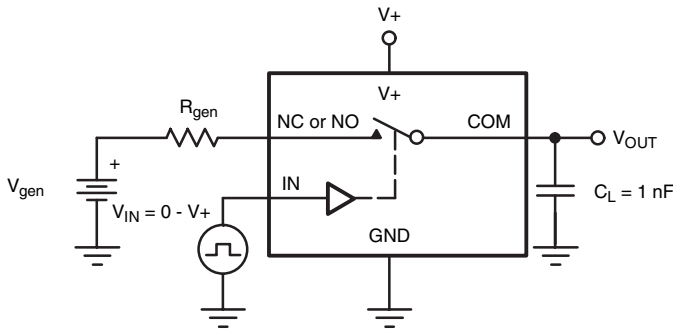

Figure 2. Break-Before-Make Interval



IN depends on switch configuration: input polarity determined by sense of switch.

Figure 3. Charge Injection

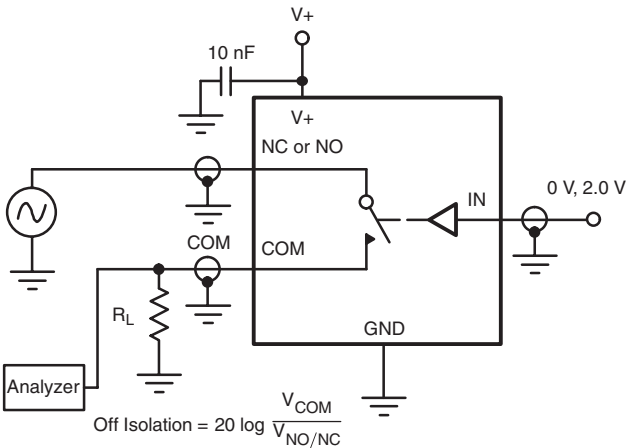

Figure 4. Off-Isolation

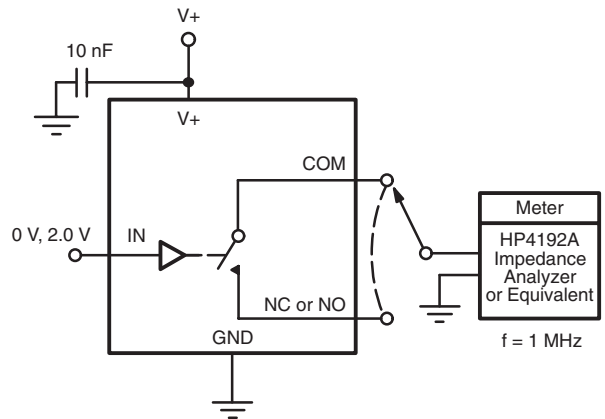

Figure 5. Channel Off/On Capacitance

Vishay Siliconix maintains worldwide manufacturing capability. Products may be manufactured at one of several qualified locations. Reliability data for Silicon Technology and Package Reliability represent a composite of all qualified locations. For related documents such as package/tape drawings, part marking, and reliability data, see <http://www.vishay.com/ppg?74333>.



Notice

Specifications of the products displayed herein are subject to change without notice. Vishay Intertechnology, Inc., or anyone on its behalf, assumes no responsibility or liability for any errors or inaccuracies.

Information contained herein is intended to provide a product description only. No license, express or implied, by estoppel or otherwise, to any intellectual property rights is granted by this document. Except as provided in Vishay's terms and conditions of sale for such products, Vishay assumes no liability whatsoever, and disclaims any express or implied warranty, relating to sale and/or use of Vishay products including liability or warranties relating to fitness for a particular purpose, merchantability, or infringement of any patent, copyright, or other intellectual property right.

The products shown herein are not designed for use in medical, life-saving, or life-sustaining applications. Customers using or selling these products for use in such applications do so at their own risk and agree to fully indemnify Vishay for any damages resulting from such improper use or sale.