



SANYO Semiconductors DATA SHEET

LA7795T — Monolithic Linear IC AGC Amplifier with Step Gain Control

Overview

The LA7795T bipolar monolithic IC is an AGC amplifier with driver amplifier for analog-to-digital converters. It is ideally suited for use with receiver systems that receive QPSK and/or QAM data transmissions.

Functions

- IF AGC control
- IF AGC amplifier
- IF step gain controlled amplifier
- Driver amplifier

Applications

- Digital CATV
- Cable modem receivers
- IP Telephony receivers

Specifications

Absolute Maximum Ratings at $T_a = 25\text{ }^\circ\text{C}$

Parameter	Symbol	Conditions	Ratings	Unit
Maximum Supply Voltage	$V_{CC\text{ max}}$	Pin 1	7.0	V
Circuit Voltages	$V\text{ max}$	Pin 4, Pin 5	$V_{CC\text{ op}}$	V
Circuit Current	I_6 I_7	Pin 6 sink current Pin 7 sink current	2 2	mA
Allowable Power Dissipation	$P_d\text{ max}$	$T_a \leq 85\text{ }^\circ\text{C}$	190*	mW
Operating Temperature	T_{opr}		-20 to +85	$^\circ\text{C}$
Storage Temperature	T_{stg}		-55 to +150	$^\circ\text{C}$

*Mounted on PCB (paper phenol $20.0 \times 10.0 \times 0.8\text{ t mm}$)

Recommended Operating Conditions at $T_a = 25\text{ }^\circ\text{C}$

Parameter	Symbol	Conditions	Ratings	Unit
Recommended Supply Voltage	V_{CC}	Pin 1	5.0	V
Operating Supply Voltage Range	$V_{CC\text{ op}}$	Pin 1	4.5 to 5.5	V

- Any and all SANYO products described or contained herein do not have specifications that can handle applications that require extremely high levels of reliability, such as life-support systems, aircraft's control systems, or other applications whose failure can be reasonably expected to result in serious physical and/or material damage. Consult with your SANYO representative nearest you before using any SANYO products described or contained herein in such applications.
- SANYO assumes no responsibility for equipment failures that result from using products at values that exceed, even momentarily, rated values (such as maximum ratings, operating condition ranges, or other parameters) listed in products specifications of any and all SANYO products described or contained herein.

LA7795T

Electrical Characteristics

AC Characteristics at $T_a = 25^\circ\text{C}$, $V_{CC} = 5.0\text{ V}$

Parameter	Symbol	Pin No.	Conditions	Ratings			Unit	
				min	typ	max		
Circuit Current	I_{total}	1	No Signal	*1	18	24	30	mA
IF Input Frequency Range	$f(in)$	2, 3	$f_c : -3\text{ dB}$	*1	30	-	100	MHz
Noise Figure	NF	6, 7	$V_4 = 3.0\text{ V}$, $f = 45\text{ MHz}$ Pin 5 : V_{CC}	*2	-	5	-	dB
			$V_4 = 3.0\text{ V}$, $f = 45\text{ MHz}$ Pin 5 : GND	*2	-	5	-	dB
			$V_4 = 3.0\text{ V}$, $f = 45\text{ MHz}$ Pin 5 : OPEN	*2	-	8	-	dB
Intermodulation	IM3	6/2, 3 7/2, 3	$f_1 = 44\text{ MHz}$, $f_2 = 45\text{ MHz}$ Input = $90\text{ dB}\mu\text{Tone}$, Output = $104\text{ dB}\mu\text{Tone}$	*1	50	-	-	dBc
Total Amplifier Gain	$G_{(AGC1)}$	6/2, 3	$V_4 = 3.0\text{ V}$, $f = 45\text{ MHz}$ Pin 5 : V_{CC}	*1	57.5	60	62.5	dB
	$G_{(AGC2)}$	7/2, 3	$V_4 = 3.0\text{ V}$, $f = 45\text{ MHz}$ Pin 5 : GND	*1	47.5	50	52.5	dB
	$G_{(AGC3)}$		$V_4 = 3.0\text{ V}$, $f = 45\text{ MHz}$ Pin 5 : OPEN	*1	33.5	36	38.5	dB
AGC Range 1	GR1	6/2, 3 7/2, 3	IF Output Level $< \pm 1\text{ dB}$, $f = 45\text{ MHz}$	*1	40	-	-	dB
IF Output Level	$V_O(IF)$	6, 7	Output Level, $f = 45\text{ MHz}$	*1	-	1.0	-	Vp-p
AGC Control Max. Voltage	V4H	4	Gain Max.	*1	2.5	-	3.3	V
AGC Control Min. Voltage	V4L	4	Gain Min.	*1	0	-	0.5	V
Input impedance	Z_{in}	2, 3	$V_4 = 0\text{ V}$, $f = 45\text{ MHz}$	*3	-	1 // 4.9	-	$k\Omega // pF$

Note) *1 : Measurement circuit 1, *2 : Measurement circuit 2, *3 : Measurement circuit 3

Package Dimensions

unit : mm

3245A [LA7795T]

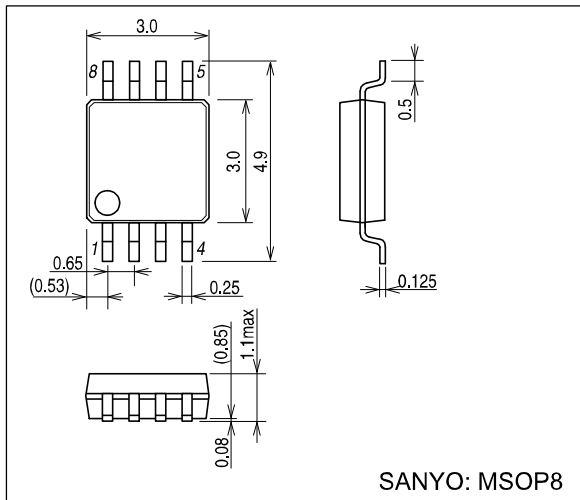

Block Diagram

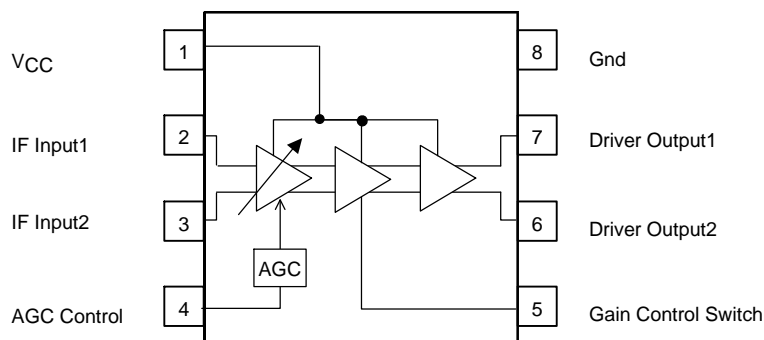

LA7795T

Pin Functions

Pin Number	Pin Name	Descriptions
1	V _{CC}	
2 3	IF Input	
4	AGC Control	
5	Gain Control Switch	
6 7	Driver Output	
8	GND	

LA7795T

LA7795T Gain Measurement Circuit 1

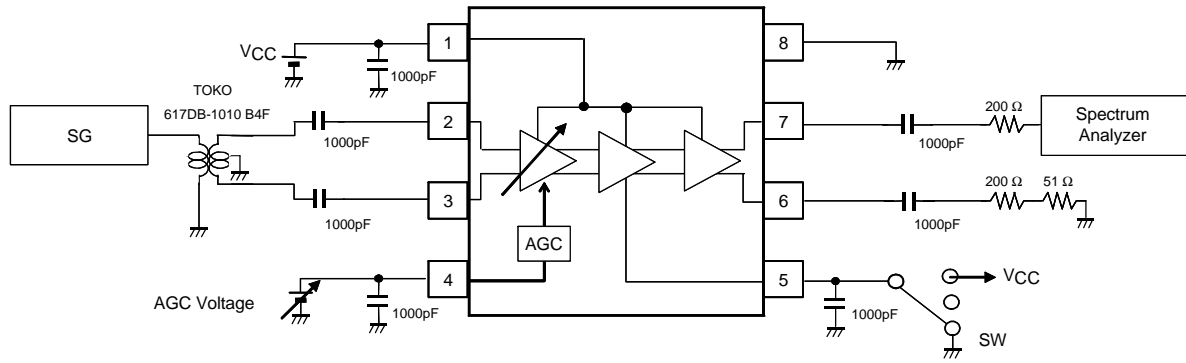

LA7795T Noise Figure Measurement Circuit 2

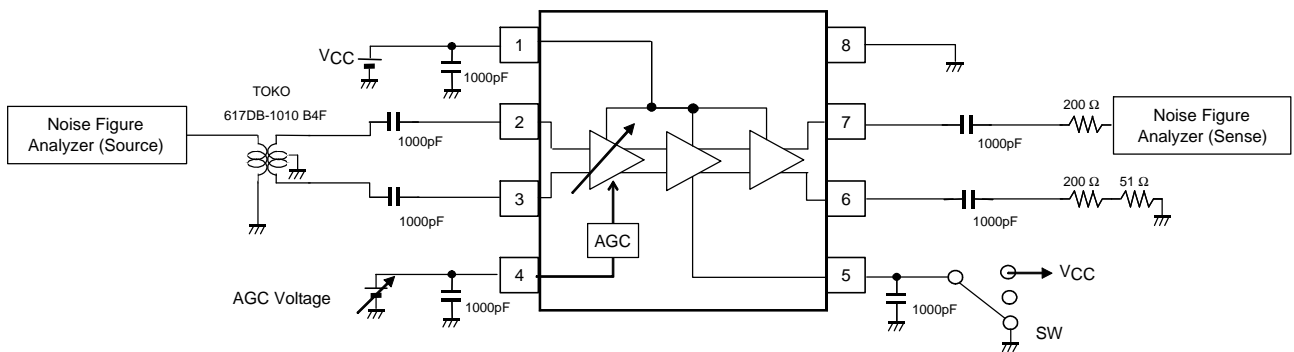

LA7795T Input Impedance Measurement Circuit 3

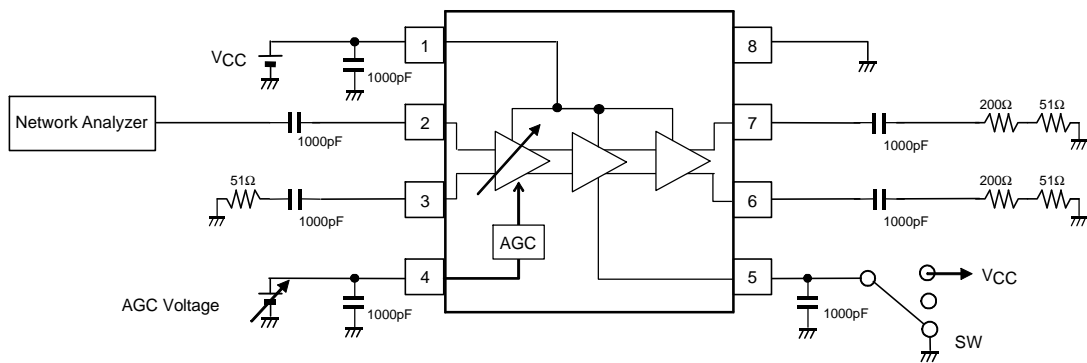

LA7795T Intermodulation Measurement Circuit 4

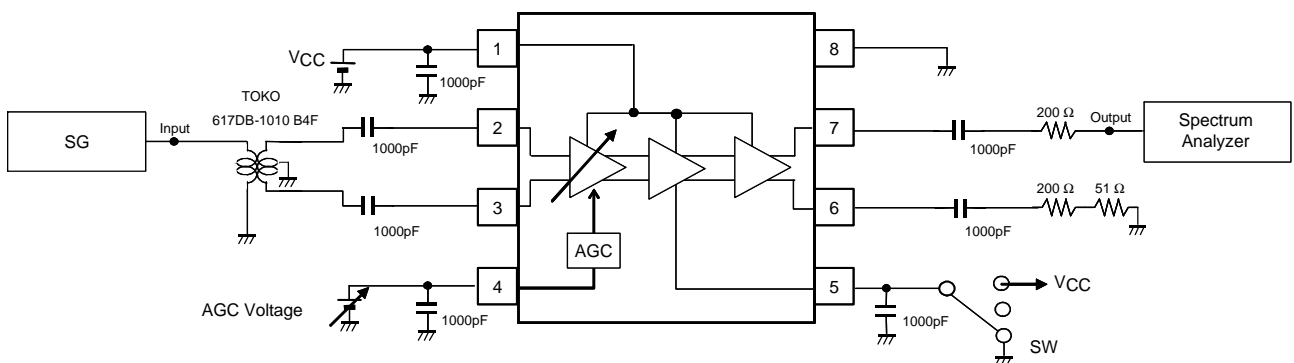

Gain - Vagc Characteristic

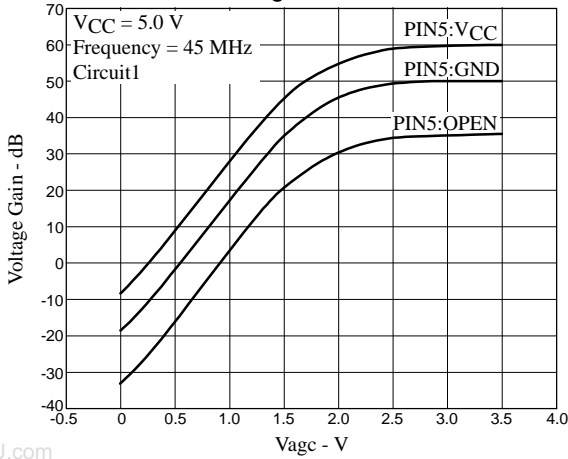

Noise Figure - Gain Characteristic

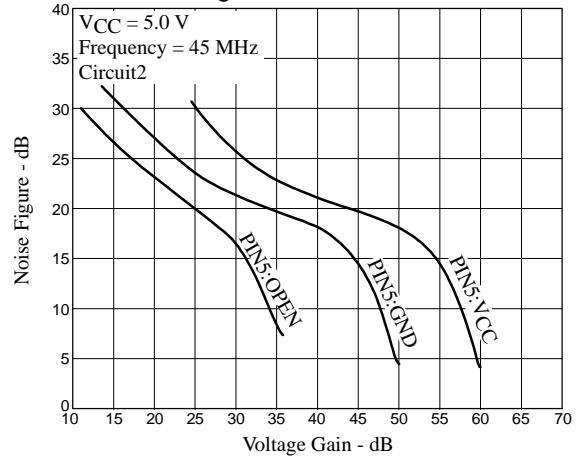

Gain - Frequency Characteristic

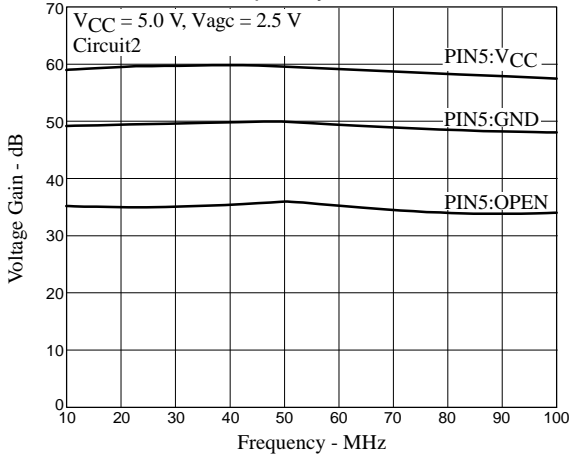

Intermodulation Characteristic

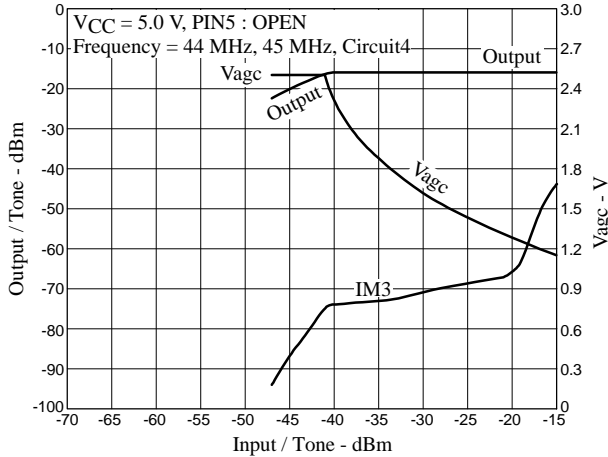

Intermodulation Characteristic

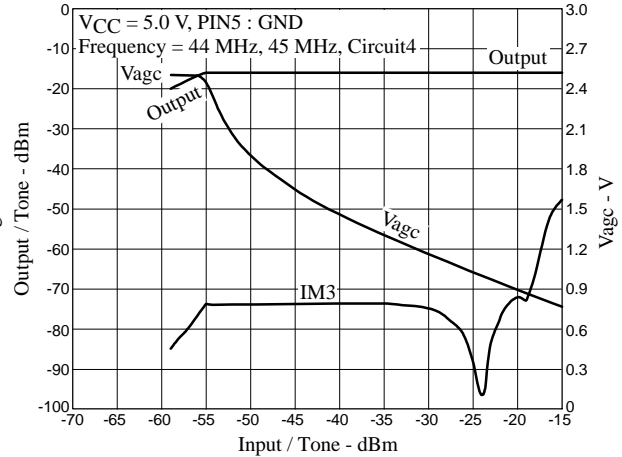

Intermodulation Characteristic

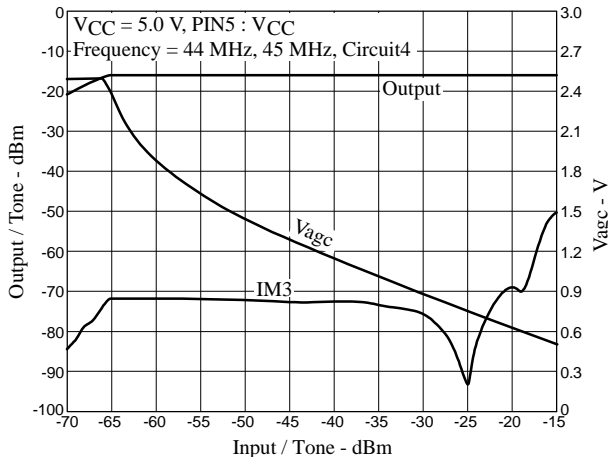

The vertical axis (Output/Tone) on this graph shows the values displayed by the spectrum analyzer for circuit 4.

The actual output power for the corresponding pins is given by the following formula.

$$\{\text{output power [dBm]}\} = \{\text{displayed value [dBm]}\} + 10 \cdot \log(250 \Omega / 50 \Omega)$$

Gain - V_{agc} Characteristic

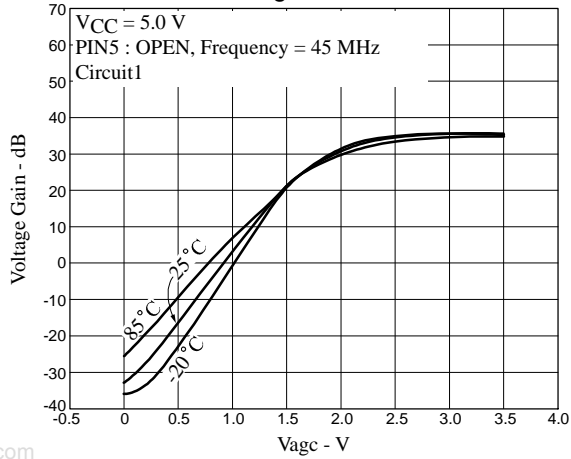

Gain - V_{agc} Characteristic

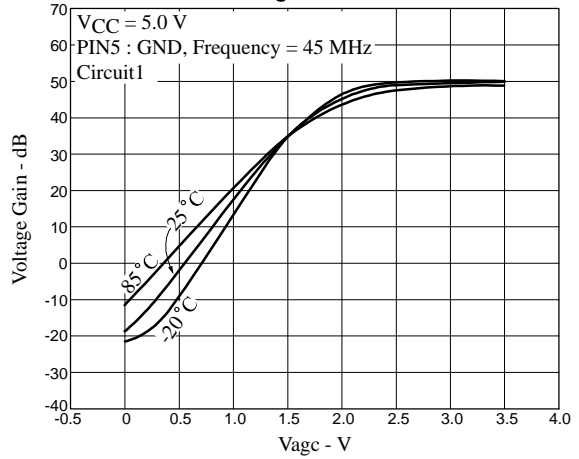

Gain - V_{agc} Characteristic

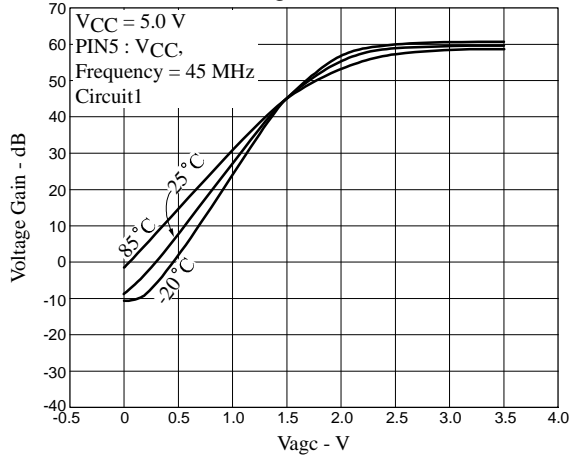

Noise Figure - Gain Characteristic

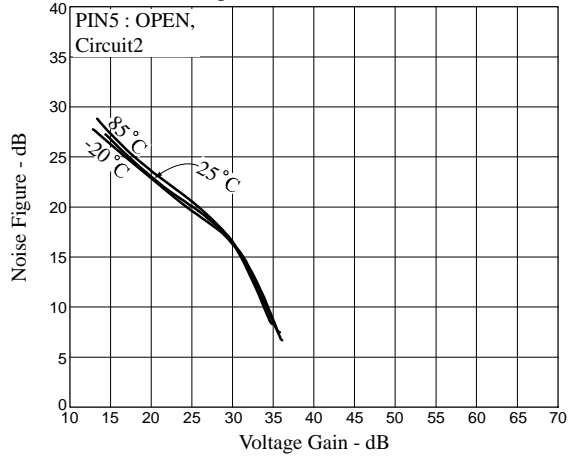

Noise Figure - Gain Characteristic

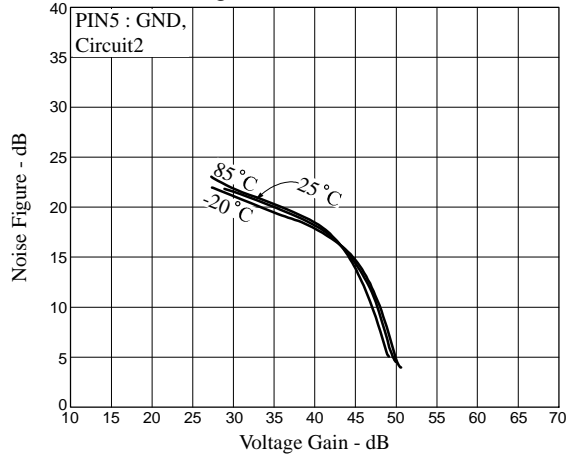

Noise Figure - Gain Characteristic

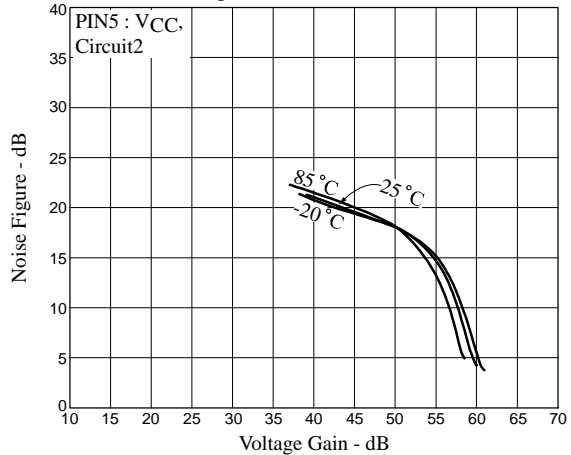

Gain - Frequency Characteristic

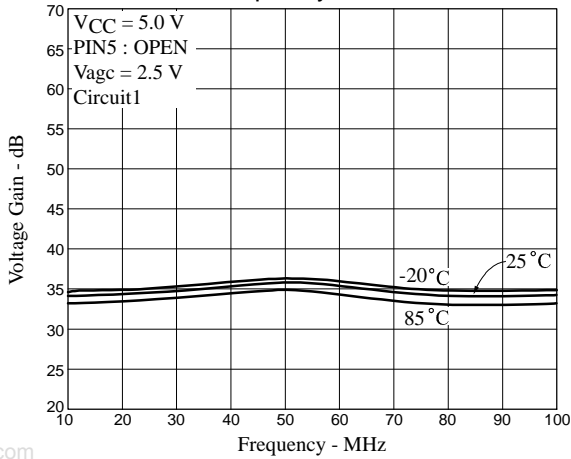

Gain - Frequency Characteristic

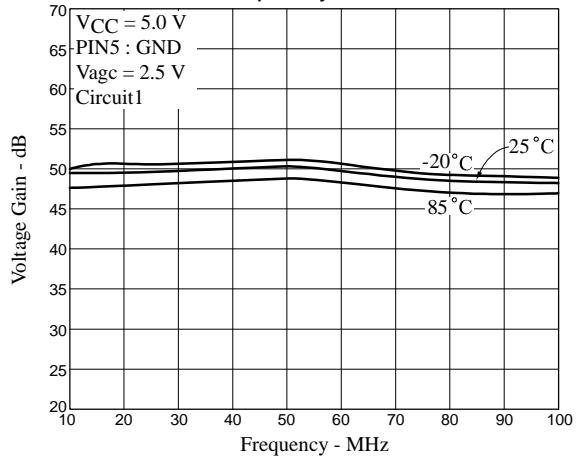

Gain - Frequency Characteristic

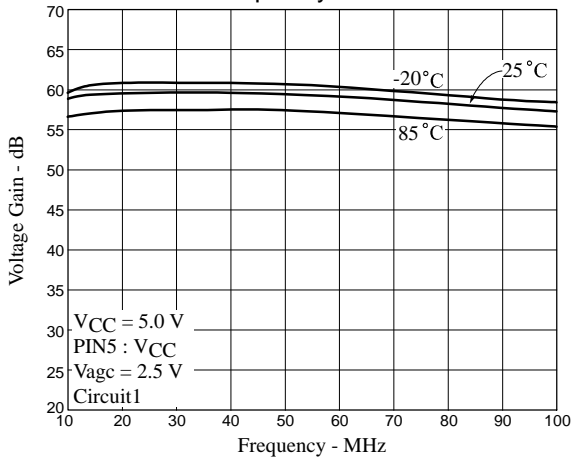

Intermodulation Characteristic

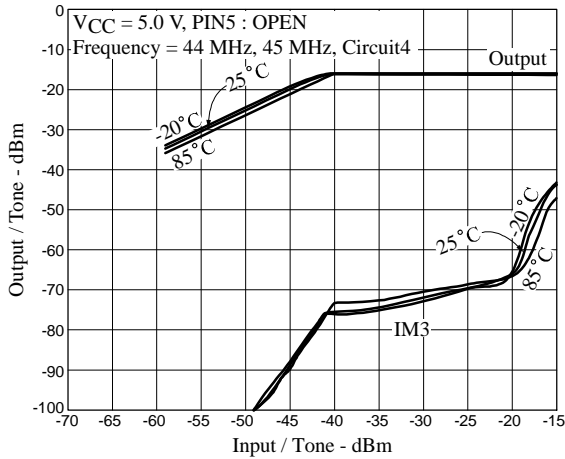

Intermodulation Characteristic

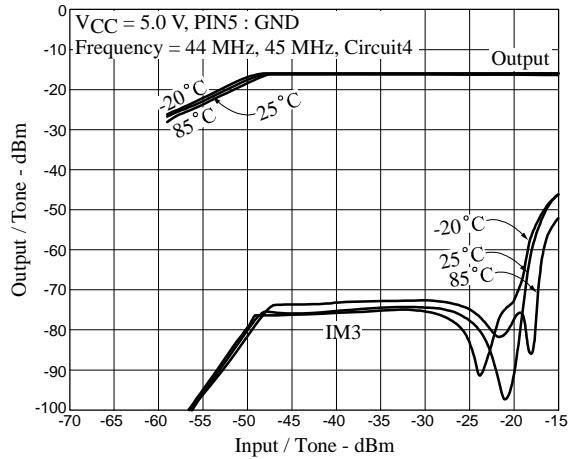

Intermodulation Characteristic

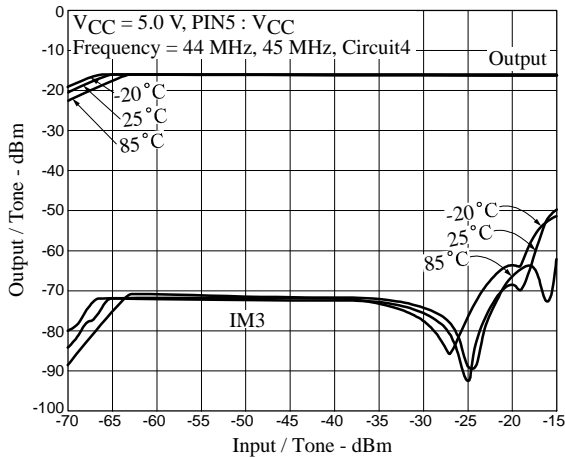

The vertical axis (Output/Tone) on this graph shows the values displayed by the spectrum analyzer for circuit 4.

The actual output power for the corresponding pins is given by the following formula.

$$\{\text{output power [dBm]}\} = \{\text{displayed value [dBm]}\} + 10 \cdot \log(250 \Omega / 50 \Omega)$$

- Specifications of any and all SANYO products described or contained herein stipulate the performance, characteristics, and functions of the described products in the independent state, and are not guarantees of the performance, characteristics, and functions of the described products as mounted in the customer's products or equipment. To verify symptoms and states that cannot be evaluated in an independent device, the customer should always evaluate and test devices mounted in the customer's products or equipment.
- SANYO Electric Co., Ltd. strives to supply high-quality high-reliability products. However, any and all semiconductor products fail with some probability. It is possible that these probabilistic failures could give rise to accidents or events that could endanger human lives, that could give rise to smoke or fire, or that could cause damage to other property. When designing equipment, adopt safety measures so that these kinds of accidents or events cannot occur. Such measures include but are not limited to protective circuits and error prevention circuits for safe design, redundant design, and structural design.
- In the event that any or all SANYO products (including technical data, services) described or contained herein are controlled under any of applicable local export control laws and regulations, such products must not be exported without obtaining the export license from the authorities concerned in accordance with the above law.
- No part of this publication may be reproduced or transmitted in any form or by any means, electronic or mechanical, including photocopying and recording, or any information storage or retrieval system, of otherwise, without the prior written permission of SANYO Electric Co., Ltd.
- Any and all information described or contained herein are subject to change without notice due to product/technology improvement, etc. When designing equipment, refer to the "Delivery Specification" for the SANYO product that you intend to use.
- Information (including circuit diagrams and circuit parameters) herein is for example only; it is not guaranteed for volume production. SANYO believes information herein is accurate and reliable, but no guarantees are made or implied regarding its use or any infringements of intellectual property rights or other rights of third parties.

This catalog provides information as of March, 2005. Specifications and information herein are subject to change without notice.