

General Description

The AHK432 is a low voltage adjustable shunt reference with thermal stability guaranteed over the full industrial temperature range. This three-terminal regulator has an output voltage range that extends from V_{REF} (1.24V) to 20V, giving designers outstanding flexibility in the development of power supplies and instrumentation. With a low operating current of 60 μ A, the AHK432 is well suited for battery-powered portable electronic applications. It also has a sharp turn-on characteristic and a dynamic resistance of only 50m Ω , making it an excellent replacement for zener diodes in low tempco designs.

The AHK432 is available in the Pb-free, surface-mount 3- or 5-pin SOT23, as well as the through hole TO-92. Three voltage tolerance options are offered in each package: $\pm 0.5\%$, $\pm 1\%$, and $\pm 2\%$.

Features

- Wide Output Voltage Range (1.24V to 20V)
- Operating Current From 60 μ A to 100mA
- Low Dynamic Output Resistance of 50m Ω
- $\pm 0.5\%$ Trimmed Voltage Reference
- 10mV (Typical) V_{REF} Deviation, From -40°C to +105°C
- Surface Mount 3- or 5-Pin SOT23 or Through-Hole 3-Pin TO-92 Package

Applications

- Adjustable and Programmable Supplies
- Global Voltage Reference for Multiple Power Supplies
- Instrumentation
- Isolated Feedback in Switching Power Supplies
- Linear Regulators (External Reference)
- Medical Electronics (see Endnote, page 10)
- Notebook Computers

Typical Application

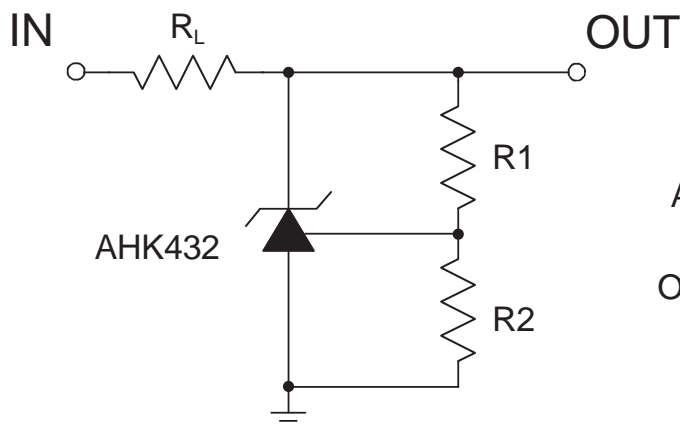

Adjustable regulator:

$$OUT = V_{REF} \left(\frac{R1 + R2}{R2} \right)$$

Pin Descriptions

Pin			Description
SOT23-3	SOT23-5	TO-92	
1	4	1	Reference.
2	3	3	Cathode.
3	5	2	Anode.
N/A	1, 2	N/A	Not internally connected.

Pin Configuration

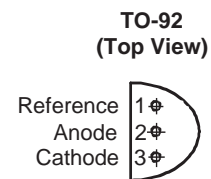
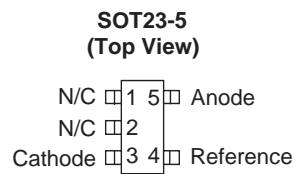
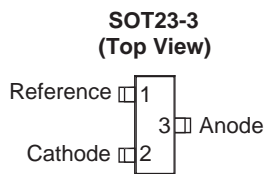

Absolute Maximum Ratings¹

$T_A = 25^\circ\text{C}$, unless otherwise noted.

Symbol	Description	Value	Units
V_Z	Cathode Voltage	20	V
I_Z	Continuous Cathode Current	100	mA
I_{REF}	Reference Current	3	mA
T_J	Operating Junction Temperature Range	-40 to 150	$^\circ\text{C}$
T_{LEAD}	Maximum Soldering Temperature (at Leads)	260	$^\circ\text{C}$

Thermal Characteristics

Symbol	Description	Package	Value	Units
Θ_{JA}	Maximum Thermal Resistance	TO-92	160	$^\circ\text{C}/\text{W}$
		SOT23-3, SOT23-5	410	
P_D	Maximum Power Dissipation	TO-92	780	mW
		SOT23-3, SOT23-5	300	

1. Stresses above those listed in Absolute Maximum Ratings may cause permanent damage to the device. Functional operation at conditions other than the operating conditions specified is not implied. Only one Absolute Maximum Rating should be applied at any one time.

Electrical Characteristics

$T_A = 25^\circ\text{C}$, unless otherwise noted.

Symbol	Description	Conditions	AHK432 0.5%			AHK432 1.0%			AHK432 2.0%			Units	
			Min	Typ	Max	Min	Typ	Max	Min	Typ	Max		
V_{REF}	Reference Voltage	$V_Z = V_{REF}$ $I_Z = 10\text{mA}$ (test circuit 1)	$T_A = 25^\circ\text{C}$	1.234	1.240	1.246	1.228	1.240	1.252	1.215	1.240	1.265	V
			$T_A = -40$ to $+105^\circ\text{C}$	1.222		1.258	1.215		1.265	1.200		1.280	
V_{DEV}	V_{REF} Temp Deviation	$T_A = -40^\circ\text{C}$ to $+105^\circ\text{C}$, $V_Z = V_{REF}$, $I_Z = 10\text{mA}$ (test circuit 1)		10	25		10	25		10	25	mV	
$\frac{\Delta V_{REF}}{\Delta V_Z}$	Ratio of Change in V_{REF} to Change in Cathode Voltage	$I_Z = 10\text{mA}$, $\Delta V_Z = 16\text{V}$ to V_{REF} (test circuit 2)		-1.0	-2.7		-1.0	-2.7		-1.0	-2.7	mV/V	
I_{REF}	Reference Input Current	$R1 = 10\text{k}\Omega$, $R2 = \infty$, $I_Z = 10\text{mA}$ (test circuit 2)		0.15	0.5		0.15	0.5		0.15	0.5	μA	
$I_{REF(DEV)}$	I_{REF} Temp Deviation	$T_A = -40^\circ\text{C}$ to $+105^\circ\text{C}$ $R1 = 10\text{k}\Omega$, $R2 = \infty$, $I_Z = 10\text{mA}$ (test circuit 2)		0.1	0.4		0.1	0.4		0.1	0.4	μA	
$I_{Z(OFF)}$	Off State Cathode Current	$V_{REF} = 0\text{V}$ (test circuit 3)	$V_Z = 6\text{V}$	0.04	0.1		0.04	0.1		0.04	0.1	μA	
			$V_Z = 16\text{V}$	0.04	0.5		0.04	0.5		0.04	0.5		
R_Z	Dynamic Output Impedance	$f < 1\text{kHz}$, $V_Z = V_{REF}$, $I_Z = 100\mu\text{A}$ to 100mA (test circuit 1)		0.05	0.2		0.05	0.2		0.05	0.2	Ω	
$I_{Z(MIN)}$	Minimum Operating Current	$V_Z = V_{REF}$ (test circuit 1)		60	80		60	80		60	80	μA	

Typical Characteristics

Unless otherwise noted, $T_A = 25^\circ\text{C}$, $I_Z = 10\text{mA}$.

Cathode Current vs. Cathode Voltage

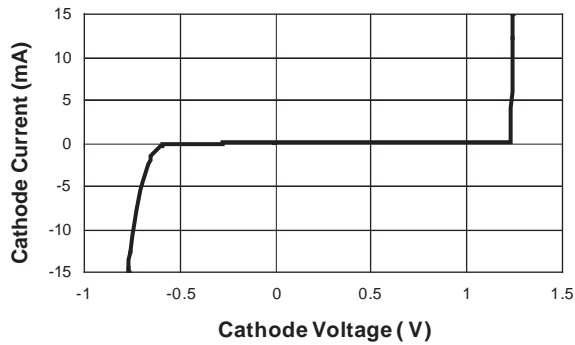

Cathode Current vs. Cathode Voltage

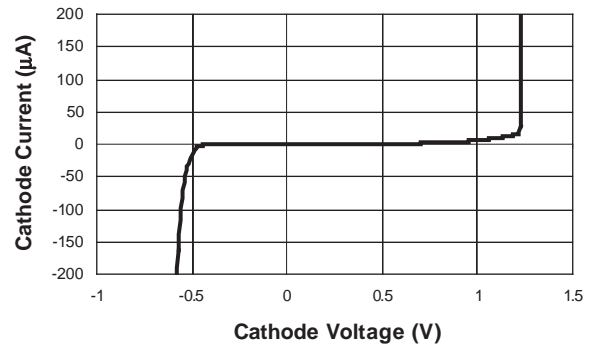

Reference Voltage vs. Temperature

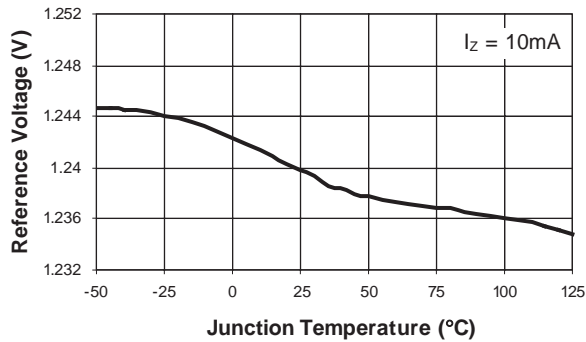

Reference Current vs. Temperature

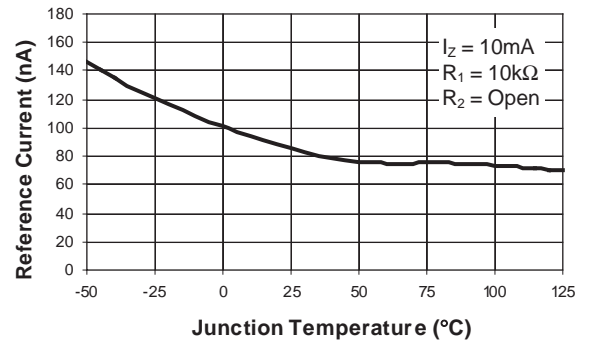

Cathode Current vs. Temperature

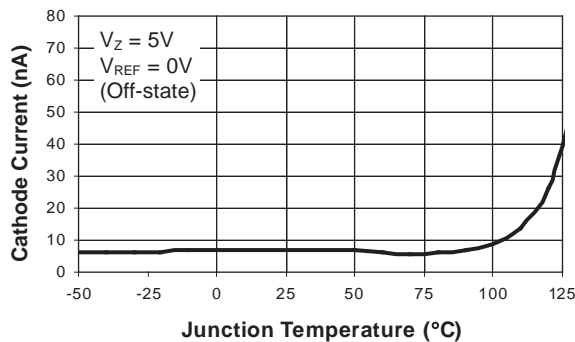

Ratio of $\Delta V_{REF} / \Delta V_Z$ vs. Temperature

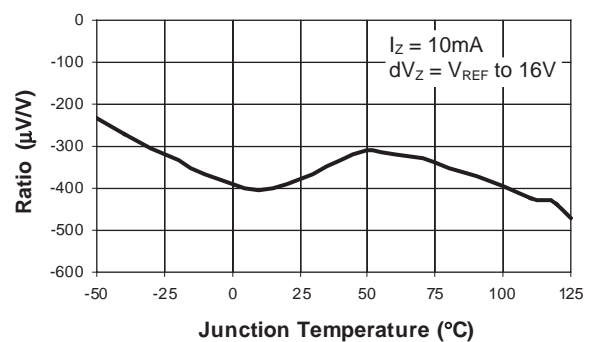

Typical Characteristics

Unless otherwise noted, $T_A = 25^\circ\text{C}$, $I_Z = 10\text{mA}$.

Cathode Impedance vs. Temperature

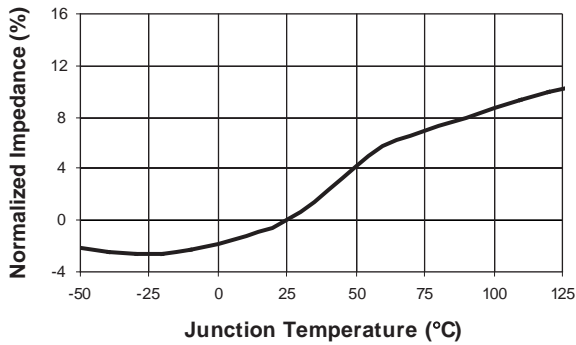

Impedance vs. Frequency

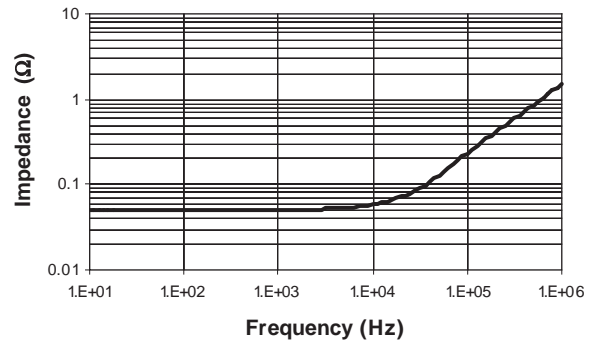

Gain and Phase vs. Frequency

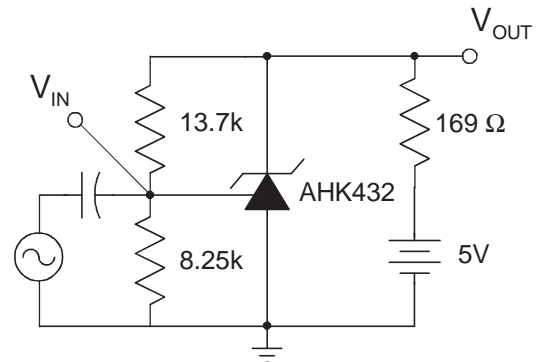
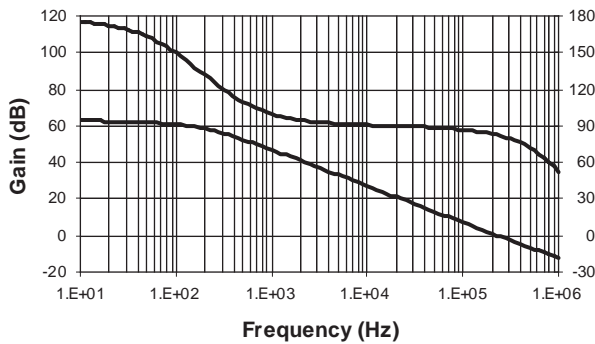

Test Circuit for Voltage Gain and Phase

Stability Boundary

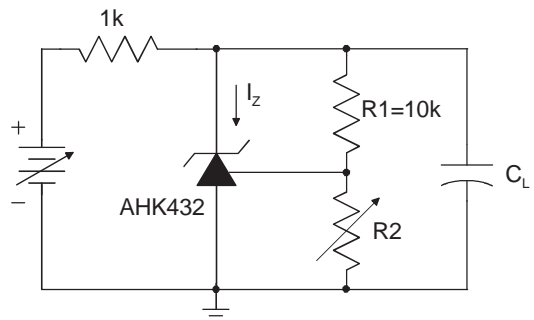
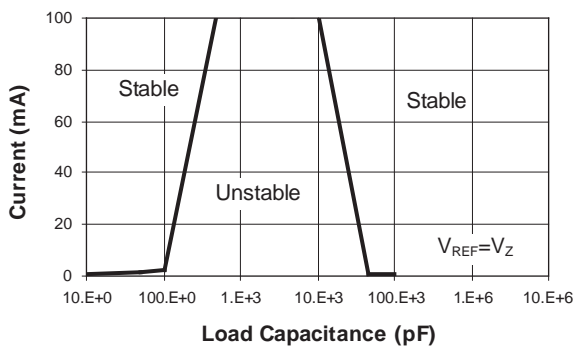

Test Circuit for Stability

Functional Block Diagram

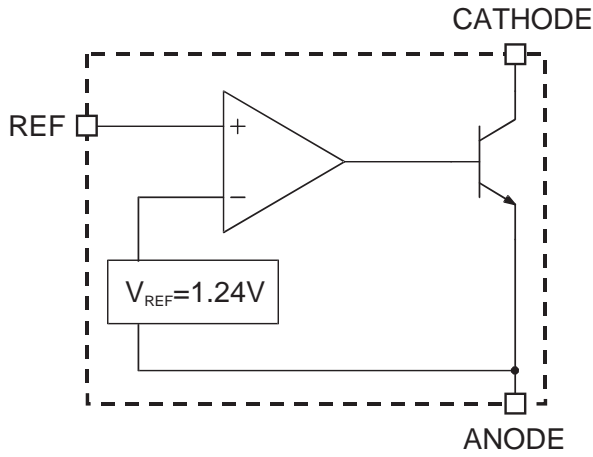

Symbol Diagram

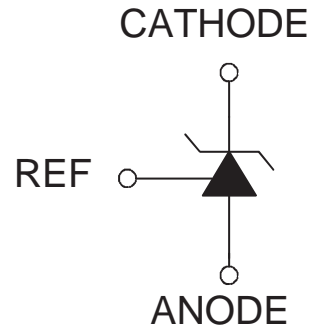

Test Circuits

Test Circuit 1

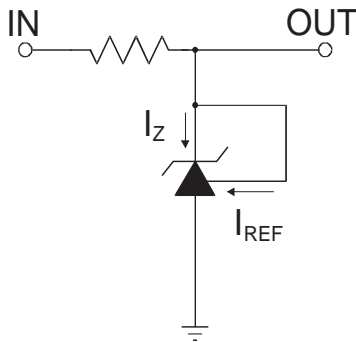

Test Circuit 2

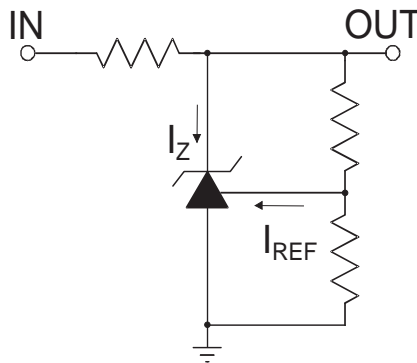

Test Circuit 3

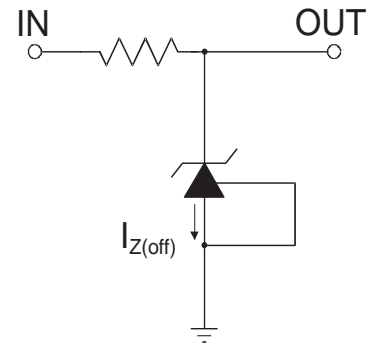

Ordering Information¹

Package	Bulk or Tape and Reel	Tolerance		
		0.5%	1.0%	2.0%
SOT23-3	Bulk	N/A	N/A	N/A
SOT23-5		N/A	N/A	N/A
TO92		AHK432ILY-.5-B1	AHK432ILY-1-B1	AHK432ILY-2-B1
SOT23-3	Tape and Reel	AHK432IGY-.5-T1	AHK432IGY-1-T1	N/A
SOT23-5		AHK432IGV-.5-T1	AHK432IGV-1-T1	N/A
TO-92	Ammo	AHK432ILY-.5-A1	AHK432ILY-1-A1	AHK432ILY-2-A1



All AnalogicTech products are offered in Pb-free packaging. The term “Pb-free” means semiconductor products that are in compliance with current RoHS standards, including the requirement that lead not exceed 0.1% by weight in homogeneous materials. For more information, please visit our website at <http://www.analogictech.com/pbfree>.

Package Information

TO-92 (Bulk packing option)

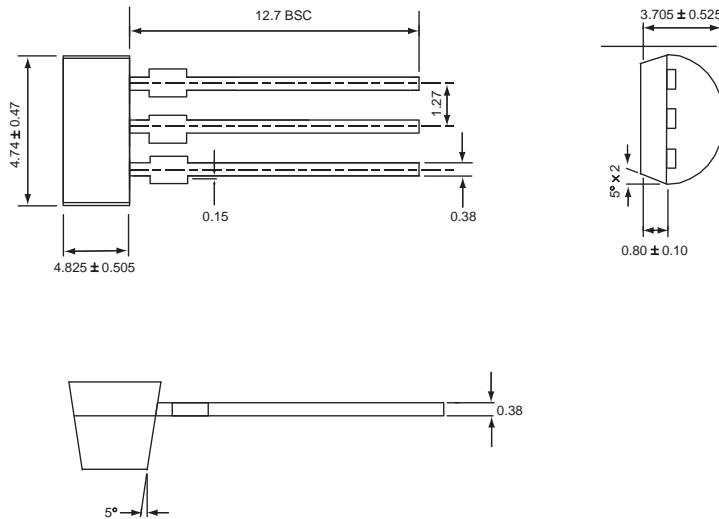

All dimensions in millimeters.

1. Sample stock is generally held on part numbers listed in **BOLD**.

TO-92 (Ammo packing option)

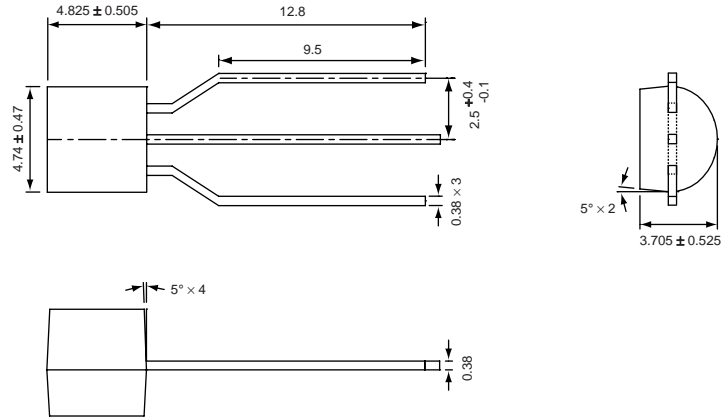

SOT23-3

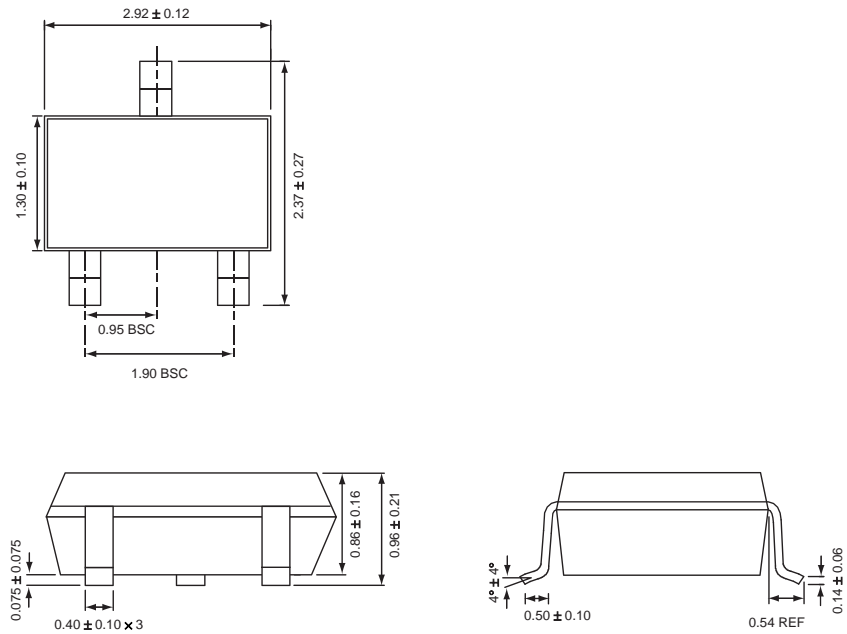

All dimensions in millimeters.

SOT23-5

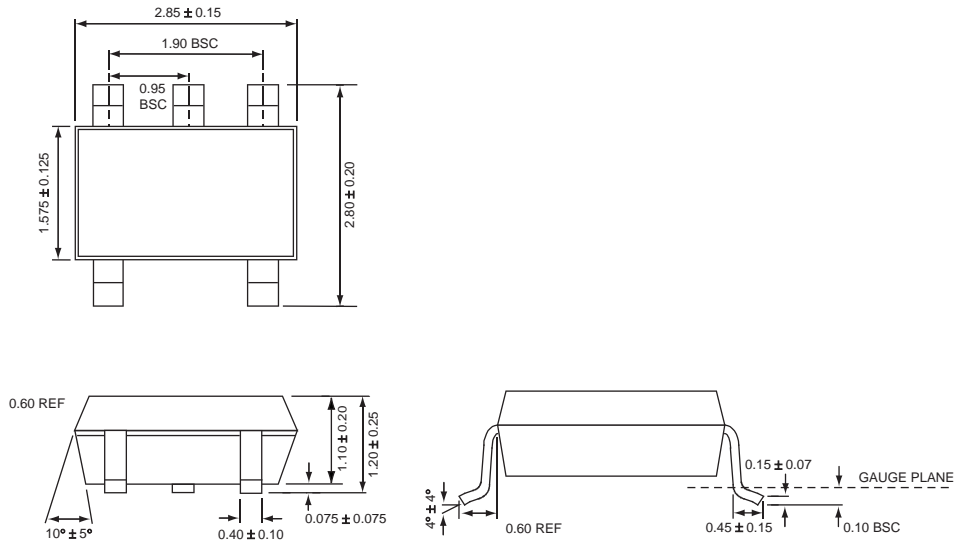

All dimensions in millimeters.

Endnote:

LIFE SUPPORT POLICY

AnalogicTech's PRODUCTS ARE NOT AUTHORIZED FOR USE AS CRITICAL COMPONENTS IN LIFE SUPPORT DEVICES OR SYSTEMS WITHOUT THE EXPRESS WRITTEN APPROVAL OF THE PRESIDENT OF Advanced Analogic Technologies Inc. As used herein:

1. Life support devices or systems are devices or systems which, (a) are intended for surgical implant into the body, or (b) support or sustain life, and whose failure to perform when properly used in accordance with instructions for use provided in the labeling, can be reasonably expected to result in a significant injury to the user.
2. A critical component is any component of a life support device or system whose failure to perform can be reasonably expected to cause the failure of the life support device or system, or to affect its safety or effectiveness.

© Advanced Analogic Technologies, Inc.

AnalogicTech cannot assume responsibility for use of any circuitry other than circuitry entirely embodied in an AnalogicTech product. No circuit patent licenses, copyrights, mask work rights, or other intellectual property rights are implied. AnalogicTech reserves the right to make changes to their products or specifications or to discontinue any product or service without notice. Customers are advised to obtain the latest version of relevant information to verify, before placing orders, that information being relied on is current and complete. All products are sold subject to the terms and conditions of sale supplied at the time of order acknowledgement, including those pertaining to warranty, patent infringement, and limitation of liability. AnalogicTech warrants performance of its semiconductor products to the specifications applicable at the time of sale in accordance with AnalogicTech's standard warranty. Testing and other quality control techniques are utilized to the extent AnalogicTech deems necessary to support this warranty. Specific testing of all parameters of each device is not necessarily performed.

Advanced Analogic Technologies, Inc.
 830 E. Arques Avenue, Sunnyvale, CA 94085
 Phone (408) 737-4600
 Fax (408) 737-4611