



Multi-Phase Core Controller for Intel® Mobile CPUs

Preliminary Technical Data

ADP3205

FEATURES

- Pin Programmable 1, 2 or 3 Phase Operation
- Excellent Static and Dynamic Current Sharing
- Superior Load Transient Response when used with ADOPT™ Optimal Positioning Technology
- Noise-Blanking for Speed and Stability
- Synchronous Rectification Control for Optimized Light Load Efficiency
- Soft DAC Output Voltage Transition for VID Change
- Cycle-by-Cycle Current Limiting
- Latched or Hiccup Current Overload Protection
- Masked Power Good during Output Voltage Transients
- Soft Start-up without Power-On In-Rush Current Surge
- Two Level Over-Voltage and Reverse-Voltage Protection

GENERAL DESCRIPTION

The ADP3205 is a 1, 2, or 3 phase hysteretic peak current mode DC-DC buck converter controller dedicated to power a mobile processor's core. The chip optimized low voltage design runs from the 3.3 V system supply. The chip contains a precision 6-bit DAC whose nominal output voltage is set by VID code. The ADP3205 features high-speed operation to allow a minimized inductor size that results in the fastest change of current to the output. To further minimize the number of output capacitors, the converter features active voltage positioning enhanced with ADOPT optimal compensation to ensure a superior load transient response. The output signals interface with ADP3415 MOSFET drivers that are optimized for high speed and high efficiency. The ADP3205 is capable of providing synchronous rectification control to extend battery lifetime in light load conditions.

APPLICATIONS

- Next Generation Intel Mobile CPU Core DC/DC Converters
- Programmable Output Power Supplies

FUNCTIONAL BLOCK DIAGRAM

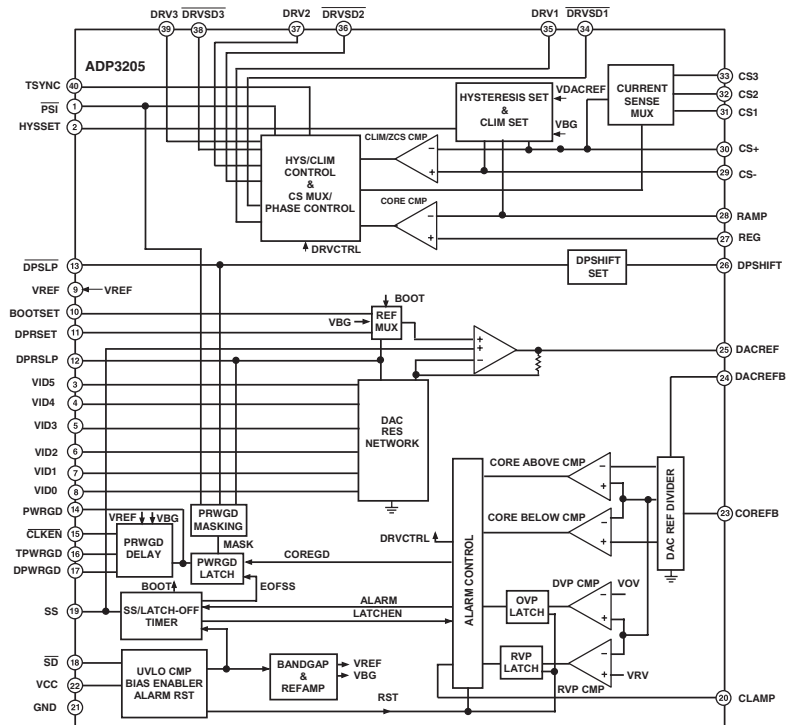

ADOPT is a trademark of Analog Devices

REV. PrK 10/23/02

Information furnished by Analog Devices is believed to be accurate and reliable. However, no responsibility is assumed by Analog Devices for its use, nor for any infringements of patents or other rights of third parties which may result from its use. No license is granted by implication or otherwise under any patent or patent rights of Analog Devices.

One Technology Way, P.O. Box 9106, Norwood, MA 02062-9106, U.S.A.
 Tel: 781/329-4700 www.analog.com
 Fax: 781/326-8703 ©ANALOG DEVICES, INC., 2002