

Remote Relay Output Link Modules

G70D-R6□□1-B7A

Ultra-compact 16-point Module Offers Relay Outputs from B7A

- Wire loads directly to terminal block, eliminating the need for relaying
- Power MOSFET or relays installed
- Built-in diode absorbs coil surge
- 500 m maximum transmission distance from controller to module
- Operation indicators show status at a glance
- Output modules offer Hold and Load OFF handling of transmission errors
- Mounts to DIN rail track or with screws



Ordering Information

■ RELAY OUTPUT LINK MODULES

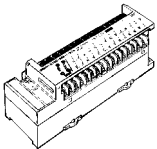
Appearance	I/O classification	Output type	I/O delay (typical)	Error processing (See Note 1)	Part number
	Output, 16 points (SPST-NO)	Relay outputs	Normal speed 19.2 ms (See Note 2)	HOLD	G70D-R6R11-B7A
				LOAD OFF	G70D-R6R31-B7A
		Power MOSFET relay outputs		HOLD	G70D-R6M11-B7A
				LOAD OFF	G70D-R6M31-B7A

- Note: 1. HOLD: The previous output condition will be on hold when an error results.
 LOAD OFF: All outputs will be OFF when an error results.
2. These G70D Relay Output Link Modules cannot be connected to high-speed B7A.

■ SWITCHING POWER SUPPLIES

Input voltage	Output rating	Application	Part number
120 to 240 VAC	0.13 A, 24 VDC	Use one to power each input or output block	S82K-00324
	0.3 A, 24 VDC	Use one to power two blocks from a single power supply	S82K-00724
	0.6 A, 24 VDC	Use this to power blocks connected to sensors, relays indicator lights	S82K-01524
	1.3 A, 24 VDC	Use one where excess power is needed	S82K-03024

■ ACCESSORIES

Item	Applicable output blocks	Rated voltage	Part number
Replacement relays	G70D-R6R11-B7A, G70D-R6R31-B7A	24 VDC; minimum load 10 mA at 5 VDC	G6D-1A DC24
	G70D-R6M11-B7A, G70D-R6M31-B7A	24 VDC	G3DZ-2R6PL DC24

Specifications

■ RATINGS

Coil Ratings (per G6D Relay)

Rated voltage	24 VDC
Rated current	10.5 mA
Coil resistance	2,880 Ω
Must operate voltage	70% max. of rated voltage
Must release voltage	10% min. of rated voltage
Max. voltage	130% of rated voltage
Power consumption	Approx. 200 mW

- Note: 1. The must operate voltage is 75% or less of the rated voltage if the relay is mounted upside down.
 2. Rated current and coil resistance were measured at a coil temperature of 23°C with a tolerance of ±10%.
 3. Operating characteristics were measured at a coil temperature of 23°C.
 4. The maximum allowable voltage is the maximum value of the allowable voltage range for the relay coil operating power supply. There is no continuous allowance.
 5. The rated current includes the terminal's LED current.

Contact Ratings (per G6D Relay)

Load	Resistive load ($\cos\phi = 1$)
Rated load	3 A at 250 VAC, 3 A at 30 VDC
Rated carry current	3 A
Max. switching voltage	250 VAC, 30 VDC
Max. switching current	3 A
Max. switching capacity	750 VA, 90 W
Min. permissible load (reference value) (See Note)	10 mA at 5 VDC

- Note: This value fulfills the P reference value of opening/closing at a rate of 120 times per min (ambient operating environment and de-termination criteria according to JIS C5442).

Input (per G3DZ Power MOSFET Relay)

Rated voltage	24 VDC	
Operating voltage	19.2 to 28.8 VDC	
Voltage level	Must operate	19.2 VDC max.
	Must release	1 VDC min.
Input impedance	4 kΩ±20%	
Rated current	8.2 mA±20%	

- Note: The rated current includes the terminal's LED current.

Output (per G3DZ Power MOSFET Relay)

Load voltage	3 to 264 VAC, 3 to 125 VDC
Load current	100 μA to 0.3 A
Inrush current	6 A (10 ms)

■ CHARACTERISTICS

Transmission Characteristics

Communication method	Unidirectional, time-division multiplex
Transmission distance (See Note)	500 m max.
I/O delay	Typical: 19.2 ms; Max.: 31 ms

- Note: Separate power supplies are required for inputs and outputs.

Item	G70D-R6R□1-B7A	G70D-R6M□1-B7A
Classification	Relay outputs	Power MOSFET relay outputs
Contact form	16 points (SPST-NO x 16)	
Contact mechanism	Single	---
Contact material	AgCdO	---
Contact resistance (See Note 2)	100 mΩ max.	---
Insulation method	---	Photodiode array
Operate time	10 ms max.	6 ms max.
Release time	10 ms max.	
Output ON-resistance	---	2.4 Ω max.
Leakage current for closed relay	---	10 μA max. (at 125 VDC)
Max. switching frequency	Mechanical: 18,000 operations/hr Rated load: 1,800 operations/hr	---
Insulation resistance	100 MΩ min. (at 500 VDC)	
Dielectric strength	1,000 VAC for 1 min between each terminal and external parts	
Noise immunity	Power supply normal: 600 V for 10 min with a pulse width of 100 ns to 1 μs Power supply common: 1.5 kV for 10 min with a pulse width of 100 ns to 1 μs Coiling around transmission path: 1.5 kV for 10 min with a pulse width of 100 ns to 1 μs Coiling around Unit: 600 V for 10 min with a pulse width of 100 ns to 1 μs	
Vibration resistance	Destruction: 10 to 55 Hz, 1.0-mm double amplitude for 2 hrs each in X, Y, and Z directions Malfunction: 10 to 55 Hz, 0.75-mm double amplitude for 2 hrs each in X, Y, and Z directions	
Shock resistance	Destruction: 300 m/s ² (approx. 30G) Malfunction: 100 m/s ² (approx. 10G)	
Operating voltage range	24 VDC ^{+10%} / _{-15%}	
Current Consumption	Approx. 300 mA at 24 VDC	
Cable length	Between block and controller: 500 m (1640 ft) max. (reference value for AWG28) Between block and external device: Dependent on load	
LED color	Operation indicator: orange; power supply: green (red for errors)	
Coil surge absorber	Diode (400 V, 300 mA)	
Life expectancy	Electrical: 100,000 operations min. (3 A at 250 VAC/30 VDC, resistive load) 300,000 operations min. (2 A at 250 VAC/30 VDC, resistive load) (at 1,800 operations/hr) Mechanical: 20,000,000 operations min. (at 18,000 operations/hr)	
Ambient temperature	Operating: 0°C to 55°C (32°F to 131°F) Storage: -20°C to 65°C (-4°F to 149°F)	
Ambient humidity	Operating: 35% to 85%	
Mounting strength	No damage when 5 kgf (49 N) pull load was applied for 1 s in all directions (except for 1 kgf (9.8 N) in direction of DIN rail)	
Terminal strength	Tightening torque: 8 to 10 kgf • cm (0.78 to 0.98 N • m) Pull strength: 5 kgf (49 N) for 1 min	
Weight	Approx. 230 g	

Note: 1. The above values are initial values.

2. Measurement condition: 1 A at 5 VDC

3. Current consumption is when all points are ON and includes G6D relay coil current. External load current and error output current are not included.

Dimensions

Unit: mm (inch)

G70D-R6□□1-B7A

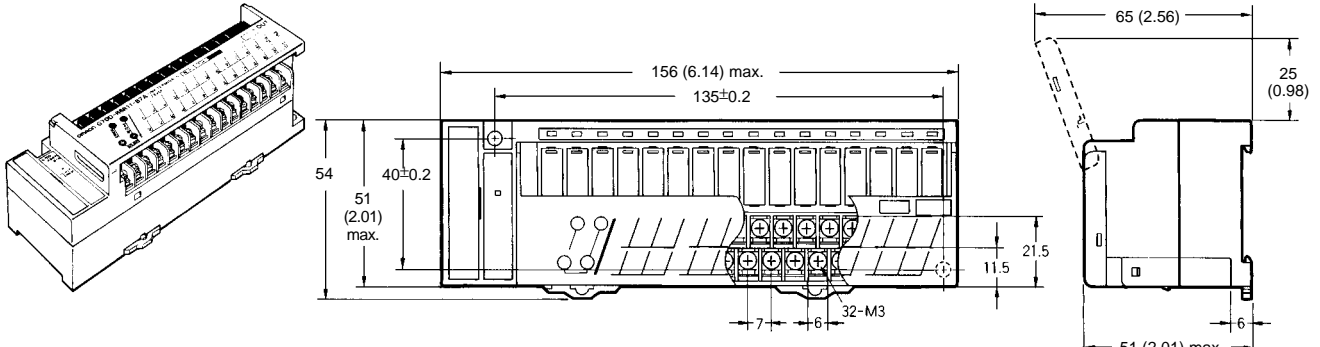

Mounting Holes

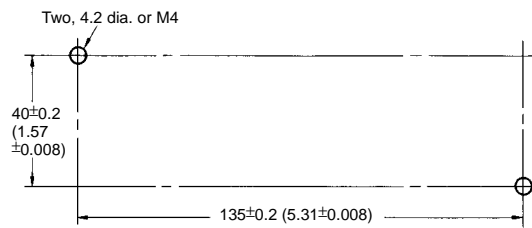

Installation

■ CONNECTION EXAMPLE

The following example shows the G70D-R6□□1-B7A combined with the B7A Master Link interface module.

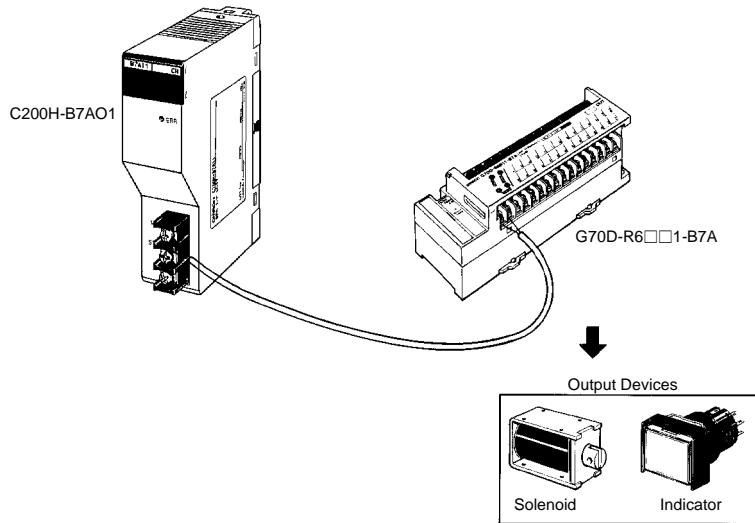

INTERNAL CIRCUIT

G70D-R6R11-B7A/G70D-R6M11-B7A
 G70D-R6R31-B7A/G70D-R6M31-B7A

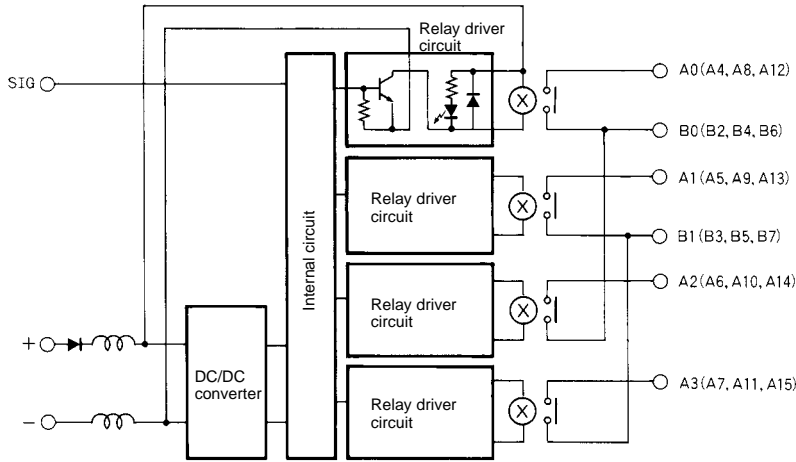

Connectable B7A Models

B7A models with 16 inputs and a standard transmission delay time (19.2 ms typ.) can be connected. Refer to documentation on the B7A.

TERMINAL ARRANGEMENT/CONNECTIONS

G70D-R6□□□-B7A

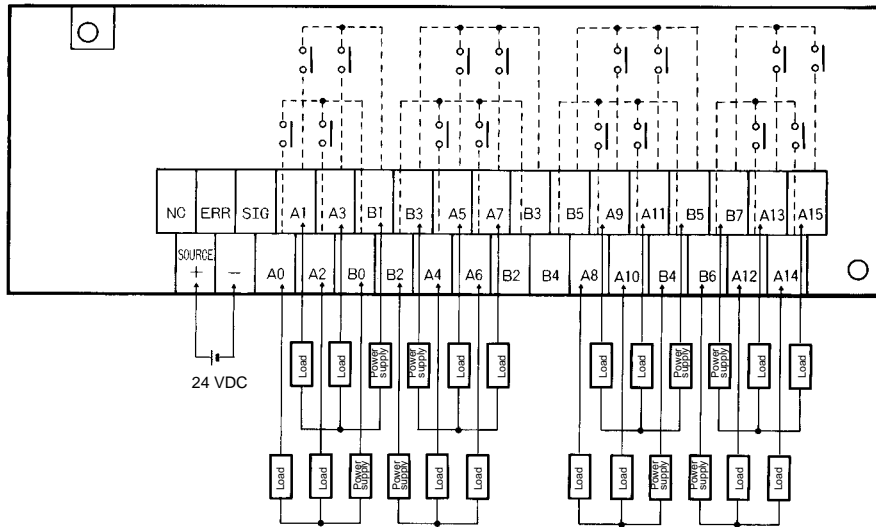

- Note: 1. Dotted lines show internal connections.
- 2. B2, B3, B4, and B5 are each found in two locations. Connect power to either of them.

Precautions

The G70D is used only for outputs.

The G70D-R6R□1-B7A is equipped with G6D-1A, 24 VDC relays; the G70D-R6M□1-B7A is equipped with G3DZ-2R6PL, 24 VDC power MOSFET relays

Use the Relay Removal Tool provided to the left of the screw terminals when replacing relays.

It is extremely dangerous to connect or disconnect relays with the power turned on. Always turn off the power before replacing relays.

To open the protective cover, lift cover at both points marked "A" in the following illustration.

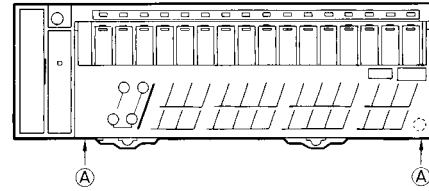

NOTE: DIMENSIONS SHOWN ARE IN MILLIMETERS. To convert millimeters to inches divide by 25.4.

OMRON[®]

OMRON ELECTRONICS, INC.

One East Commerce Drive
Schaumburg, IL 60173

1-800-55-OMRON

OMRON CANADA, INC.

885 Milner Avenue
Scarborough, Ontario M1B 5V8

416-286-6465