



L11810

Preliminary

CMOS IC

1A CMOS LOW DROPOUT VOLTAGE

DESCRIPTION

As UTC LDO, the features of the UTC **L11810** include low quiescent current and very low dropout voltage.

In order to prevent from the bad operating conditions, there are internal thermal shutdown and current fold-back. For stably operation, the UTC **L11810** should be connected to an output capacitance of 2.2 μ F or larger.

The UTC **L11810** is ideal for battery applications, such as portable electronics, wireless devices, cordless phones, PC peripherals and battery powered widgets.

FEATURES

- * Extra low dropout voltage
- * Output current: 1A (guaranteed)
- * Output voltage accuracy: $\pm 1.5\%$
- * Quiescent current: 30 μ A
- * Internal Over-Temperature shutdown
- * With Current limiting
- * Internal short circuit current fold-back
- * Pre-set output voltages in factory
- * Very low temperature coefficient
- * Halogen Free

ORDERING INFORMATION

Ordering Number	Package	Pin Assignment			Packing
L11810G-xx-AA3-A-R	SOT-223	G	O	I	Tape Reel
L11810G-xx-AA3-D-R	SOT-223	I	G	O	Tape Reel

Note: Pin Assignment: G:GND O:V_{OUT} I:V_{IN}

xx: Output Voltage, refer to Marking Information.

<p>L11810G-xx-AA3-A-R</p>	<p>(1) Packing Type</p> <p>(2) Pin Code</p> <p>(3) Package Type</p> <p>(4) Output Voltage Code</p> <p>(5) Halogen Free</p>	<p>(1) R: Tape Reel</p> <p>(2) Pin Assignment</p> <p>(3) AA3: SOT-223</p> <p>(4) xx: Refer to Marking Information</p> <p>(5) G: Halogen Free</p>
---------------------------	--	--

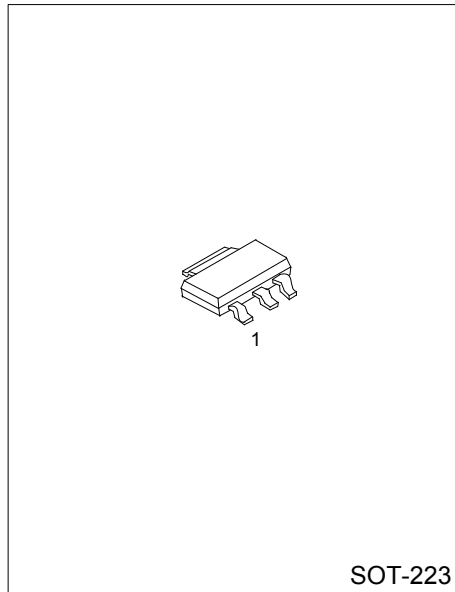

■ MARKING INFORMATION

PACKAGE	VOLTAGE CODE	MARKING
SOT-223	28 :2.8V 33 :3.3V	

■ PIN CONFIGURATION

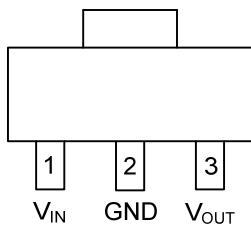

■ PIN DESCRIPTION

PIN NO	PIN NAME	DESCRIPTION
1	V _{IN}	Input voltage pin which should be decoupled with 1μF or greater capacitor.
2	GND	Ground.
3	V _{OUT}	Output voltage pin which should be decoupled with a ceramic capacitor (value: 2.2μF or larger and low ESR).

■ BLOCK DIAGRAM

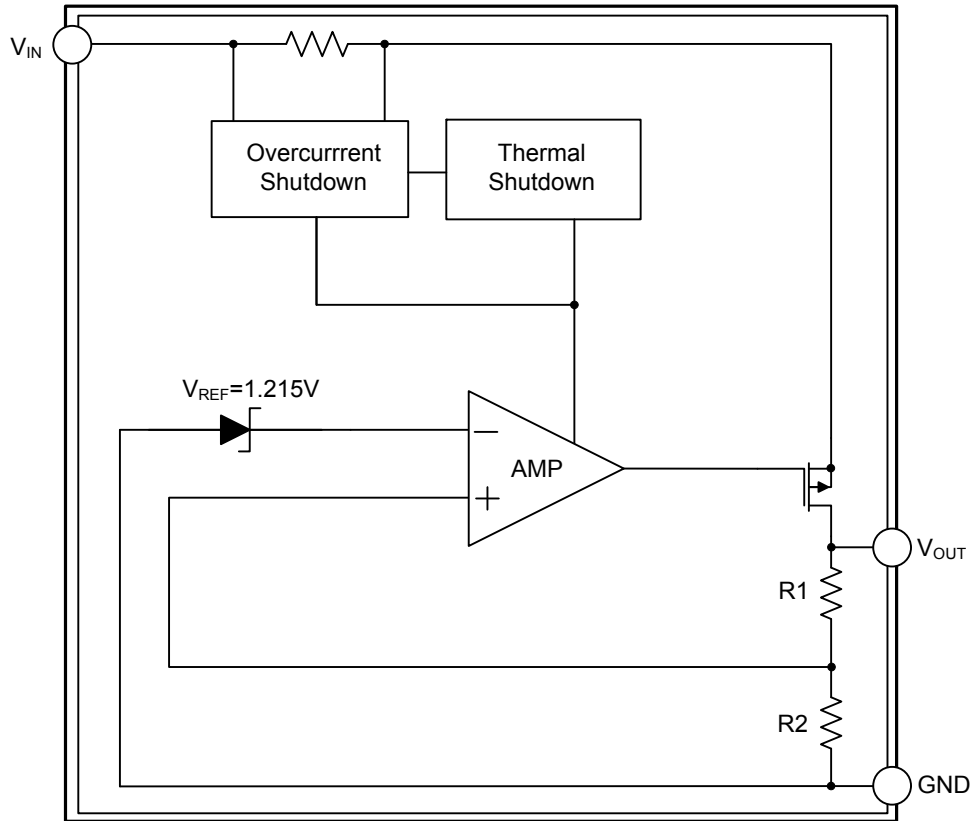

■ ABSOLUTE MAXIMUM RATING

PARAMETER	SYMBOL	RATINGS	UNIT
Input Voltage	V_{IN}	8	V
Input ,Output Voltage		GND - 0.3 ~ $V_{IN} + 0.3$	V
Output Current	I_{OUT}	1.2	A
Power Dissipation	P_D	900	mW
Junction Temperature	T_J	125	°C
Operating Temperature	T_{OPR}	- 40 ~ +85	°C
Storage Temperature	T_{STG}	- 65 ~ +150	°C

Note: Absolute maximum ratings are those values beyond which the device could be permanently damaged.
Absolute maximum ratings are stress ratings only and functional device operation is not implied.

■ THERMAL DATA

PARAMETER	SYMBOL	RATINGS	UNIT
Junction to Ambient	θ_{JA}	120	°C/W
Junction to Case (Note)	θ_{JC}	25	°C/W

Note: Measure θ_{JC} on backside center of tab

■ ELECTRICAL CHARACTERISTICS (Ta = 25°C, unless otherwise specified.)

PARAMETER	SYMBOL	TEST CONDITIONS	MIN	TYP	MAX	UNIT	
Input Voltage	V_{IN}		Note1		7	V	
Output Voltage Accuracy	V_{OUT}	$I_{OUT} = 1mA$	-1.5		1.5	%	
Line Regulation	$\frac{\Delta V_{OUT}}{V_{OUT}}$	$I_{OUT} = 1mA,$ $V_{IN} = V_{OUT} + 1 \sim V_{OUT} + 2$	$1.8V \leq V_{OUT} \leq 2.0V$	-0.15	0.02	0.15	%
			$2.0V < V_{OUT} < 4.0V$	-0.1	0.02	0.1	%
			$V_{OUT} \geq 4.0V$	-0.4	0.2	0.4	%
Load Regulation	$\frac{\Delta V_{OUT}}{V_{OUT}}$	$I_{OUT} = 1mA \sim 1000mA$		0.4	1.2	%	
Output Current	I_{OUT}	$V_{OUT} \geq 1.8V$	1000			mA	
Current Limit	I_{LIMIT}	$V_{OUT} \geq 1.8V$	1100			mA	
Short Circuit Current	I_{SC}	$V_{OUT} < 0.8V$		400	800	mA	
Quiescent Current	I_Q	$I_{OUT} = 0mA$		30	50	μA	
Ground Pin Current	I_{GND}	$I_{OUT} = 1mA \sim 1000mA$		35		μA	
Dropout Voltage	V_D	$I_{OUT} = 1A$ $V_{OUT} = V_{OUT(NOM)} - 2.0\%$	$1.8V \leq V_{OUT(NOM)} \leq 2.0V$			1700	mV
			$2.0V < V_{OUT(NOM)} \leq 2.8V$			1200	mV
			$2.8V < V_{OUT(NOM)}$			1000	mV
Over Temperature Shutdown	OTS			150		°C	
Over Temperature Hysteresis	OTH			30		°C	
Temperature Coefficient of Output Voltage	$T_C V_O$			30		ppm/°C	
Power Supply Ripple Rejection	PSRR	$I_{OUT} = 100mA$ $C_O = 2.2\mu F$	$f = 100Hz$		60		dB
			$f = 1kHz$		50		dB
			$f = 10kHz$		20		dB
Output Voltage Noise	eN	$I_{OUT} = 10mA, C_{OUT} = 2.2\mu F, f = 10Hz \sim 100kHz$		30		μV_{RMS}	

Notes: 1. $V_{IN(MIN)} = V_{OUT} + V_D$

2. To prevent the Short Circuit Current protection feature from being prematurely activated, the input voltage must be applied before a current source load is applied.

■ TYPICAL APPLICATION CIRCUIT

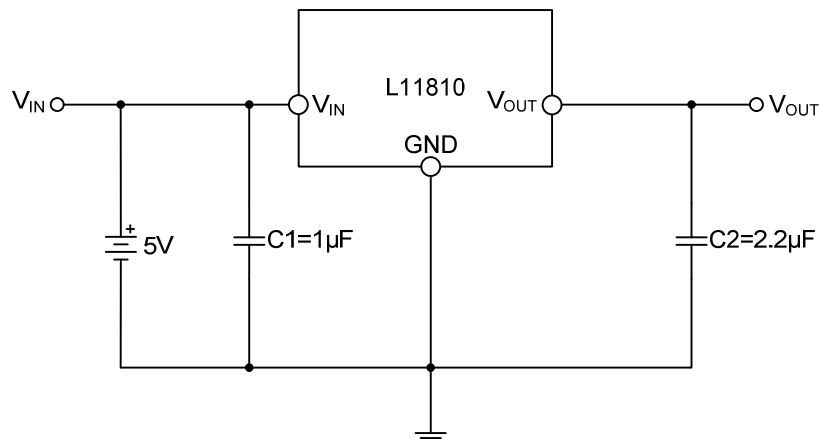

■ APPLICATION INFORMATION

1. Detailed Description

Internal circuits include: a PMOS pass transistor, voltage reference, error amplifier, over-current protection, and thermal shutdown.

The data through the error amplifier, over-current shutdown, and thermal protection circuits, then to the P-channel pass transistor.

As soon as the junction temperature exceeds 150°C or the current exceeds 1100mA, over-current and thermal shutdown circuits start working. When the junction temperature drops below 120°C, normal operation is restored.

When the load exceeds the rated output current, for preventing the over stress, the chip switches from voltage mode to current mode.

2. External Information

When considering the external capacitors, the L11810 is stable with an output capacitor to ground of 2.2µF or greater. As we know, the ceramic capacitors have the lowest ESR but can offer the best AC performance; the aluminum electrolytic capacitors exhibit the highest ESR but offer the poorest AC response. And also large value ceramic capacitors are expensive. Consider all the situation, the best way is to parallel a 0.1µF ceramic capacitor with a 10µF Aluminum Electrolytic (low ESR, high capacitance, and low overall cost).

For better beneficial effecting, the input capacitor should be at least 0.1µF.

UTC assumes no responsibility for equipment failures that result from using products at values that exceed, even momentarily, rated values (such as maximum ratings, operating condition ranges, or other parameters) listed in products specifications of any and all UTC products described or contained herein. UTC products are not designed for use in life support appliances, devices or systems where malfunction of these products can be reasonably expected to result in personal injury. Reproduction in whole or in part is prohibited without the prior written consent of the copyright owner. The information presented in this document does not form part of any quotation or contract, is believed to be accurate and reliable and may be changed without notice.

