

INTRODUCTION

The KA22901/D is a monolithic integrated circuit which consists of a one-chip tuner and a no adjustment FM multiplex for AM/FM radios and headphone radios.

FEATURES

- One chip tuner with built-in FM Multiplex
- No adjustment for FM detector and VCO
- No AM detect coil, IF coupling capacitor, FM IF bypass capacitor needed
- Built-in AM/FM selection switch
- Minimum number of external parts required
- Wide operating voltage range: $V_{CC} = 1.8V \sim 7V$
- Low distortion (FM IF: 0.4 %, AM IF : 1%, MPX: 0.2% (Typ))

ORDERING INFORMATION

Device	Package	Operating Temperature
KA22901	24-SDIP-300	- 20°C ~ +75°C
KA22901D	24-SOP-375	

24-SDIP-300

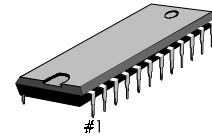

24-SOP-375

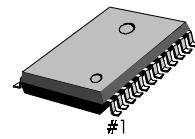

BLOCK DIAGRAM

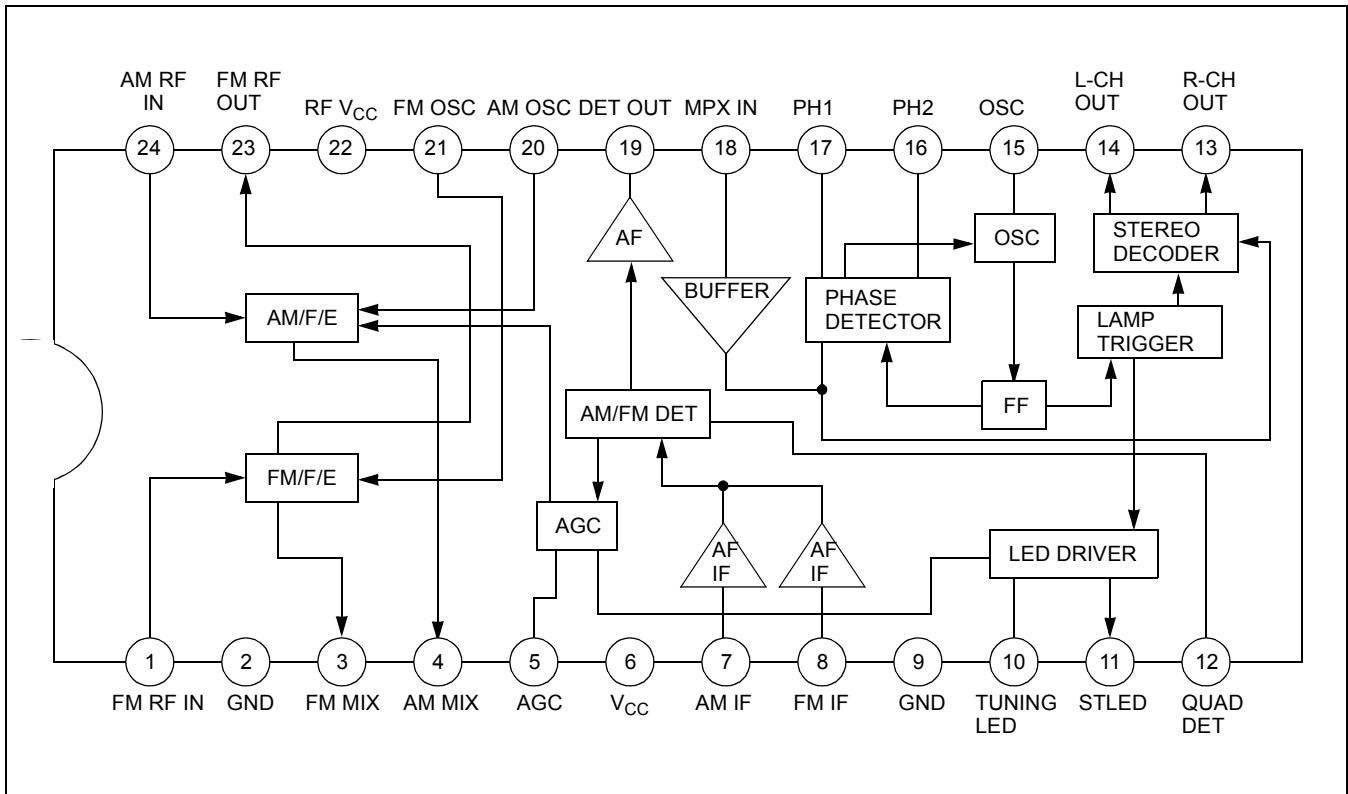

Figure 1.

ABSOLUTE MAXIMUM RATINGS (Ta = 25 °C)

Characteristic	Symbol	Value	Unit
Supply Voltage	V _{CC}	8	V
Power Dissipation	P _D	1200	mW
Operating Temperature	T _{OPR}	-20 ~ +75	°C
Storage Temperature	T _{STG}	-55 ~ +150	°C
LED Driver Voltage	V _{DR}	10	V
LED Driver Current	I _{DR}	10	mA

ELECTRICAL CHARACTERISTICS

(Ta = 25 °C, V_{CC} = 3 V, unless otherwise specified)

- FM F/E: f = 98MHz, fm = 1kHz, Δf = 22.5kHz AM: f = 1MHz, fm = 1kHz, 30 % Mod
- FM IF: f = 10.7MHz, fm = 1kHz, Δf = 22.5kHz MPX: f = 1kHz, L + R = 90%, P = 10%, V_I = 150mV

Characteristic		Symbol	Test Conditions	Min.	Typ.	Max.	Unit	Test Circuit
Quiescent Circuit Current		I _{CCQ1}	FM, V _I = 0	10	14	18	mA	1
		I _{CCQ2}	AM, V _I = 0	3.5	6.0	9	mA	1
F/E	-3 dB Limiting Sensitivity	V _{I(LIM)1}	V _O = -3dB	10	14	18	dBμ	1
	Oscillation Voltage	V _{OSC}	f _{OSC} = 98MHz	70	105	140	mV	2
FM IF	-3 dB Limiting Sensitivity	V _{I(LIM)2}	V _O = -3dB	39	44	49	dBμ	1
	Detector Output Voltage	V _{O(DET)1}	V _I = 80dBμ	55	80	110	mV	1
	Signal to Noise Ratio	S/N ₁	V _I = 80dBμ	60	70	-	dB	1
	Total Harmonic Distortion	THD ₁	V _I = 80dBμ	-	0.4	1	%	1
	AM Rejection Ratio	AMR	V _I = 80dBμ	40	50	-	dB	1
	Tuning Indication Voltage	V _{LI}	I _{LED} = 1mA	39	44	49	dBμ	1
AM IF	Voltage Gain	G _{V1}	V _I = 23dBμ	20	40	80	mV	1
	Detector Output Voltage	V _{O(DET)2}	V _I = 60dBμ	50	60	100	mV	1
	Signal to Noise Ratio	S/N ₂	V _I = 60dBμ	34	44	-	dB	1
	Total Harmonic Distortion	THD ₂	V _I = 60dBμ	-	1	2	%	1
	Tuning Indication Voltage	V _{LI2}	I _{LED} = 1mA	19	24	30	dBμ	1

	Characteristic	Symbol	Test Conditions	Min.	Typ.	Max.	Unit	Test Circuit
MPX	Maximum Input Voltage	$V_{I(MAX)}$	Stereo, THD = 3%	250	350	–	mV	1
	Channel Separation	CS_1	Stereo, f = 100Hz	35	42	–	dB	1
		CS_2	Stereo, f = 1kHz	35	42	–	dB	1
		CS_3	Stereo, f = 10kHz	35	42	–	dB	1
	Total Harmonic Distortion	THD_3	Mono	–	0.2	1	%	1
		THD_4	Stereo	–	0.2	1	%	1
	Voltage Gain	G_{V2}	Mono	–5	–3	–1	dB	1
	Channel Balance	CB	Mono	–2	0	2	dB	1
	Lamp on Level	$V_{L(ON)}$	Pilot only	–	8	16	mV	1
		$V_{L(OFF)}$	Pilot only	2	6	–	mV	1
	Lamp Hysteresis	HY	–	–	2	–	mV	1
	Capture Range	CR	Pilot only	–	± 3	–	%	1
Signal to Noise Ratio	S/N_3	Mono	60	70	–	dB	1	

TEST CIRCUIT 1

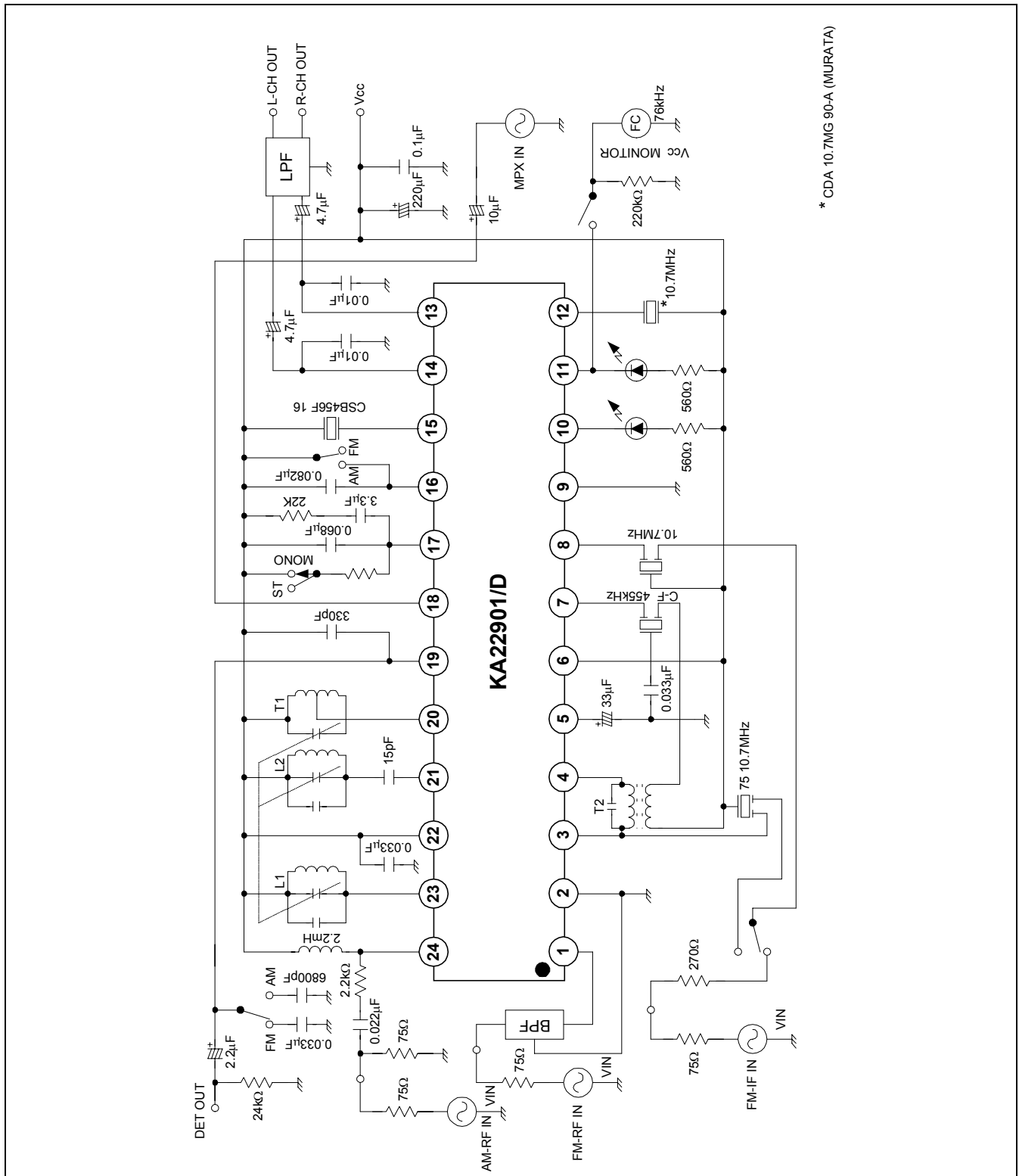

Figure 2.

TEST CIRCUIT 2

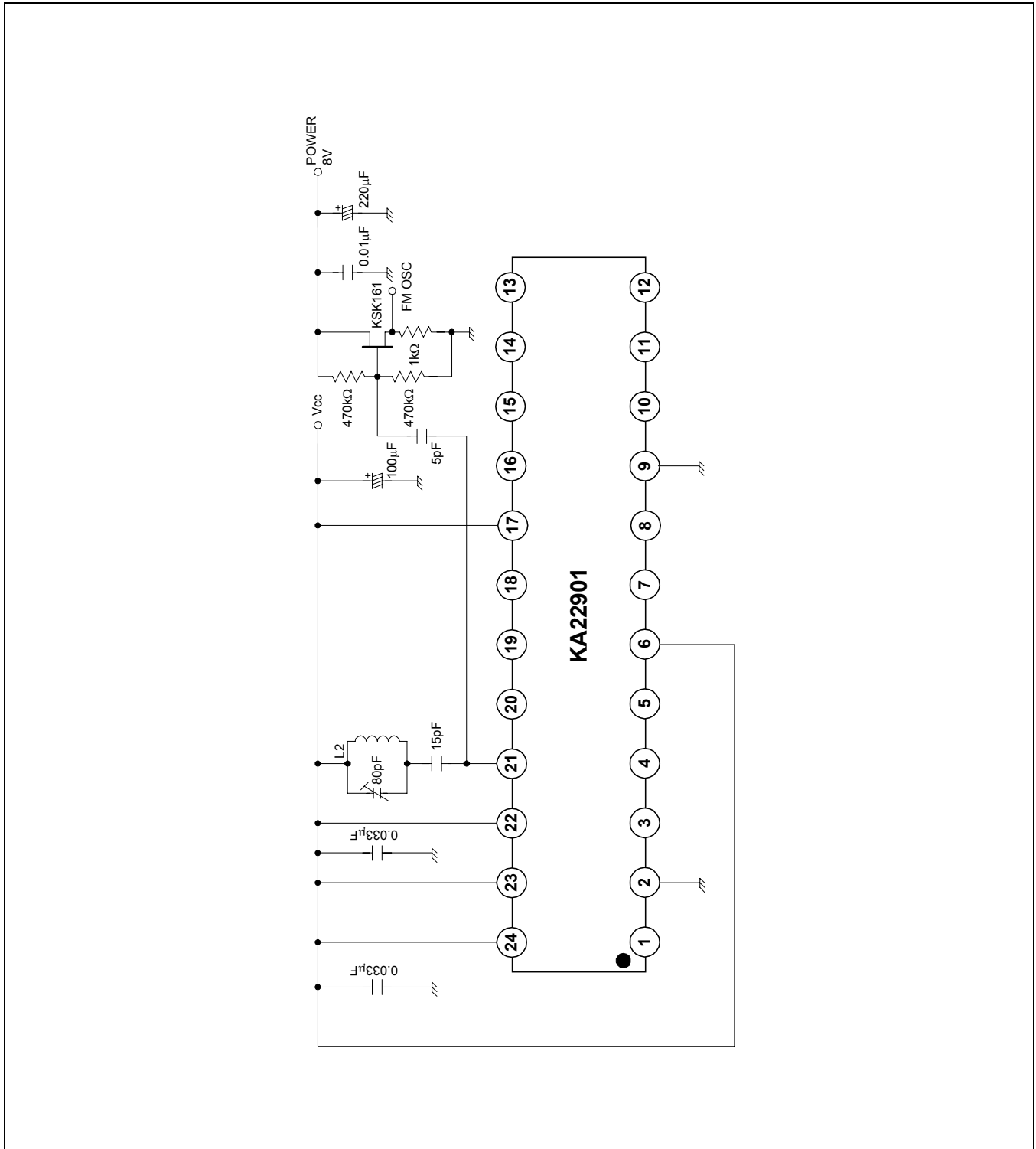
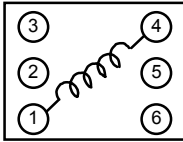

Figure 3.

COIL SPECIFICATION

L1 FM RF



f (MHz)	Qo	TURNS		
		1-4		
100	100	2 1/2		

0.5mmΦ

L2 FM OSC

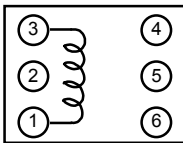

f (MHz)	Qo	TURNS		
		1-3		
100	100	2 3/4		

0.5mmΦ

T1 AM OSC

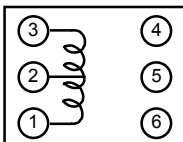

f (MHz)	Qo	TURNS			L (uH)
		1-3	2-3		
796	115	13	73		288

KOREA TOKO
0.08mmΦ

T2 AM IFT (MIX OUT)

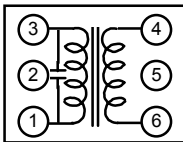

Co (pF)	f (MHz)	Qo	TURNS		
1-3			1-3	4-6	
180	455	120	180	15	

KOREA TOKO
0.08mmΦ

L1 FM RF

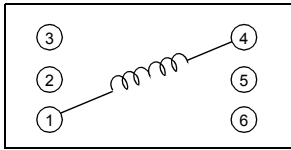

KST-FR1

F (MHz)	Qo	TURNS		KWANG SUNG PART NO
		1-4	WIRE	
100	100	2*(1/2)	0.5m/m	KST-FR1

L2 FM OSC

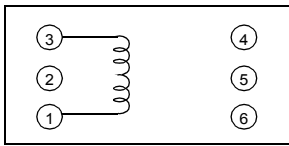

KST-FO1

F (MHz)	Qo	TURNS		KWANG SUNG PART NO
		1-3	WIRE	
100	100	2*(3/4)	0.5m/m	KST-FO1

T1 AM OSC

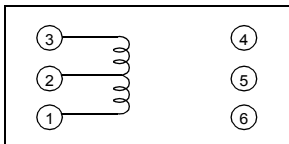

KSI-AO1

F (MHz)	Qo	TURNS		L (uH)	KWANG SUNG PART NO
		1-3	2-3		
796	115	13	73	288	KSI-AO1

T2 AM IFT (MEX OUT)

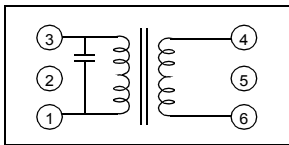

KSI-AA1

Co(pF)	F (kHz)	Qo	TURNS		KWANG SUNG PART NO
			1-3	4-6	
180	455	120	146	14	KSI-AA1

APPLICATION CIRCUIT

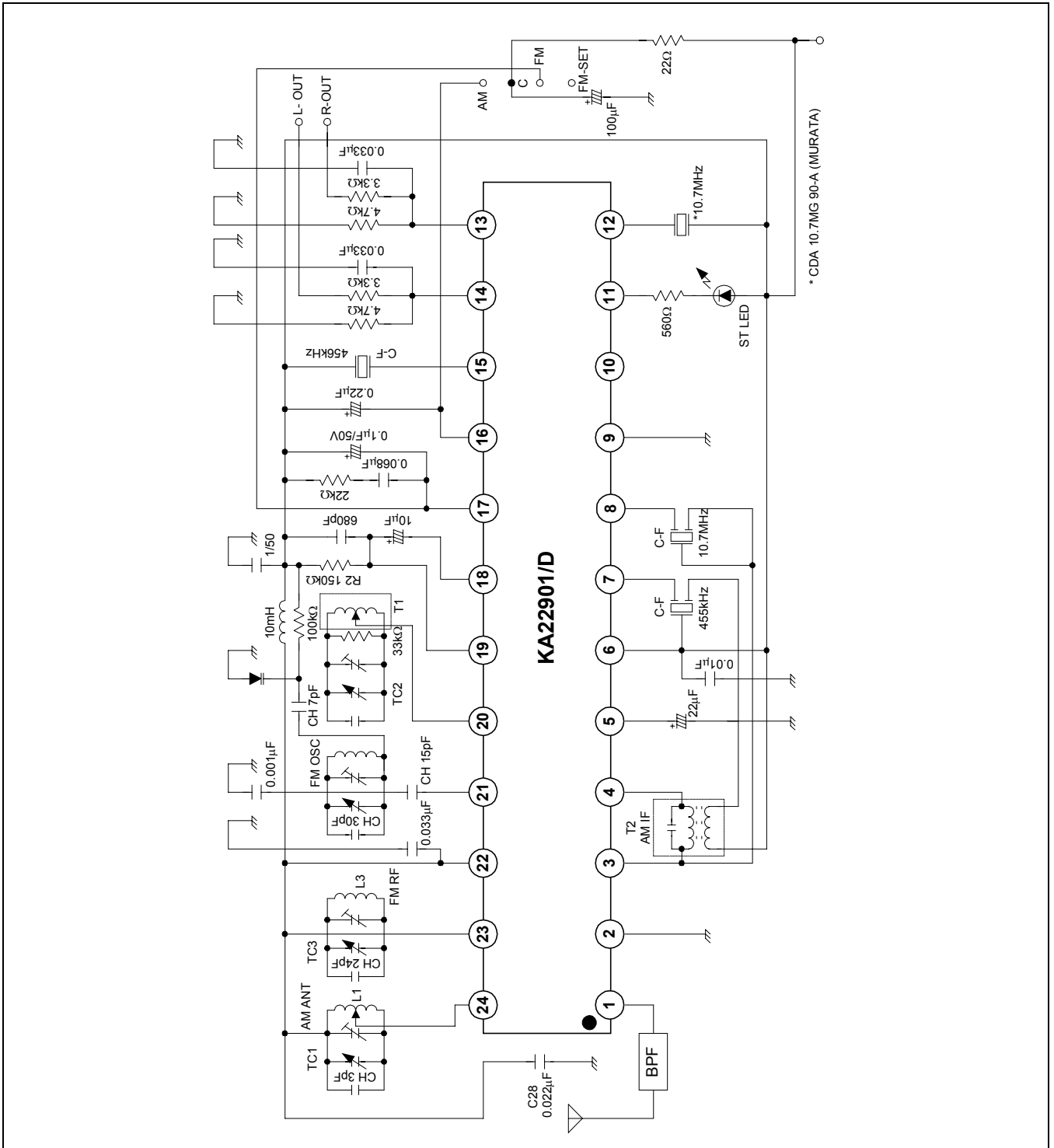

Figure 4.

NOTES