



3513

CMOS IC

PC POWER SUPPLY SUPERVISOR

DESCRIPTION

The UTC **3513** is designed to provide protection circuits, power good output (PGO) indicator, fault protection output (FPOB) and a PSONB control for PC switching power supply systems.

The protection circuits include over voltage protection (OVP), under voltage protection (UVP) and over current protection(OCP) monitoring for 3.3V, 5V and two 12V.

When 3.3V, 5V or 12V voltage is decreasing to 2.68V, 4.3V and 9.9V respectively, the under voltage protection (UVP) function will be enabled. FPO will be set to high to turn off the PWM controller IC. Toggling the PSONB from low to high will reset the fault protection latch.

The voltage difference across external current shunt is used for OCP functions. An external resistor can be used to adjust protection threshold.

The power supply is turned on after 38mS delay time when PSONB signal is set from high to low. To turn off power supply, PSONB signal is set from low to high with the delay time 38mS. The PGI circuitry provides a power-down warning signal for PGO. When PGI input is lower than the internal 1.20V reference voltage, PGO signal is pulled low.

The device is available in two versions: UTC **3513E/3513F**. Specially, fan control function is available in OTP/FC pin of UTC **3513F**.

FEATURES

- * OVP/UVP monitors 3.3V, 5V, 12V input voltage level.
- * OCP monitors I_{S33} , I_{S5} , I_{S12} input current sense.
- * Fault protection output (FPOB) with Open Drain Output stage.
- * Power good output (PGO) with Open Drain Output stage.
- * 38ms de-bounce time for PSONB input signal.
- * 300ms time delay from PGI to PGO.
- * 2.4ms time delay for PSONB to turn off FPOB.

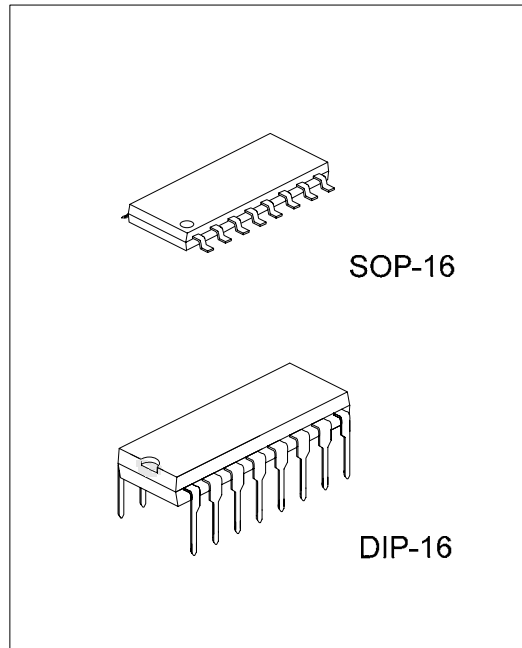

* Pb-free plating product number: 3513EL/3513FL

■ ORDERING INFORMATION

Order Number		Package	Packing
Normal	Lead Free Plating		
3513E-D16-T	3513EL-D16-T	DIP-16	Tube
3513E-S16-R	3513EL-S16-R	SOP-16	Tape Reel
3513E-S16-T	3513EL-S16-T	SOP-16	Tube
3513F-D16-T	3513FL-D16-T	DIP-16	Tube
3513F-S16-R	3513FL-S16-R	SOP-16	Tape Reel
3513F-S16-T	3513FL-S16-T	SOP-16	Tube

<p>3513EL-D16-T</p> <p>(1)Packing Type (2)Package Type (3)Lead Plating</p>	<p>(1) R: Tape Reel, T: Tube (2) D16: DIP-16, S16: SOP-16 (3) L: Lead Free Plating, Blank: Pb/Sn</p>
--	--

■ PIN ASSIGNMENT

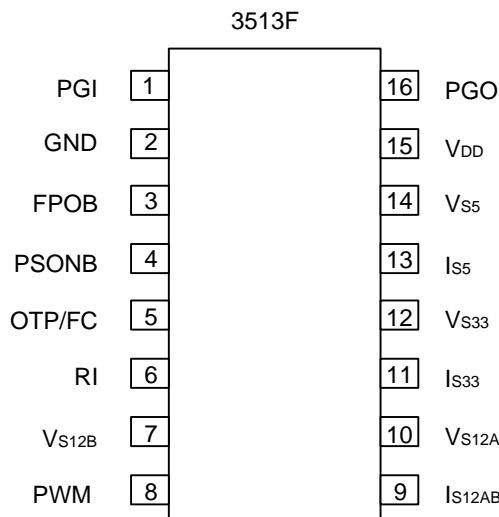
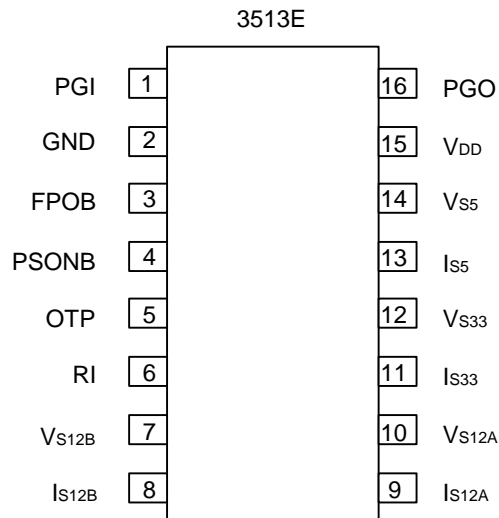

■ FUNCTION DESCRIPTION (1)

ORDERING	OTP low level	OTP high level	FC/PWM	T(PSONB ON)/ T(PSONB OFF)	tg2
3513E	2.45V	3.25V	X	38ms	73μs
3513F	2.45V	3.25V		38ms	73μs

■ FUNCTION DESCRIPTION (2)

PGI	PSONB	UV&OC Protection	OV Protection	FPOB	PGO
PGI<1.2V	L	No	No	L	L
PGI<1.2V	L	No	Yes	H	L
PGI<1.2V	L	Yes	No	L	L
PGI<1.2V	L	Yes	Yes	H	L
PGI>1.2V	L	No	No	L	H
PGI>1.2V	L	No	Yes	H	L
PGI>1.2V	L	Yes	No	H	L
PGI>1.2V	L	Yes	Yes	H	L
X	H	X	X	H	L

Note: FPOB=L means: fault is not latched. FPOB=H means: fault is latched

PGO=L means: fault. PGO=H means: No fault

X=do not care

■ PIN DESCRIPTIONS

PIN NO	PIN NAME	TYPE	DESCRIPTION
1	PGI	Input	Power Good Input. For ATX SMPS, it detects AC line voltage through the main transformer.
2	GND	Supply	Ground
3	FPOB	Output	Fault Protection Output. Output signal to control the primary PWM IC through an opto-coupler. When FPOB is low, the PWM IC is enabled.
4	PSONB	Input	Remote On/Off logic input from CPU or main-board. The power supply will be turned on/off after 38mS delay.
5	OTP/FC	Input	Over temperature protection/Fan speed control
6	RI	Input	Reference setting. One external resistor Ri connected between RI and GND pin will determine a reference current, $I_{REF} = 1.20/R_i$, for OCP programming.
7	V _{S12B}	Input	12V over/under voltage protection.
8	I _{S12B} *	Input	12V over current protection.
8	P _{WM} **	Output	Pulse width modulation.
9	I _{S12A} *	Input	12V over current protection.
9	I _{S12AB} **	Input	12V over current protection.
10	V _{S12A}	Input	12V over/under voltage protection.
11	I _{S33}	Input	3.3V over current protection
12	V _{S33}	Input	3.3V over/under voltage protection
13	I _{S5}	Input	5V over current protection.
14	V _{S5}	Input	5V over/under voltage protection.
15	V _{DD}	Supply	Power supply.
16	PGO	Output	Power good logic output, 0 or 1(open-drain). Power good=1 means that the power supply is good for operation. The power good delay is 300mS.

* 3513E only

** 3513F only

■ BLOCK DIAGRAM

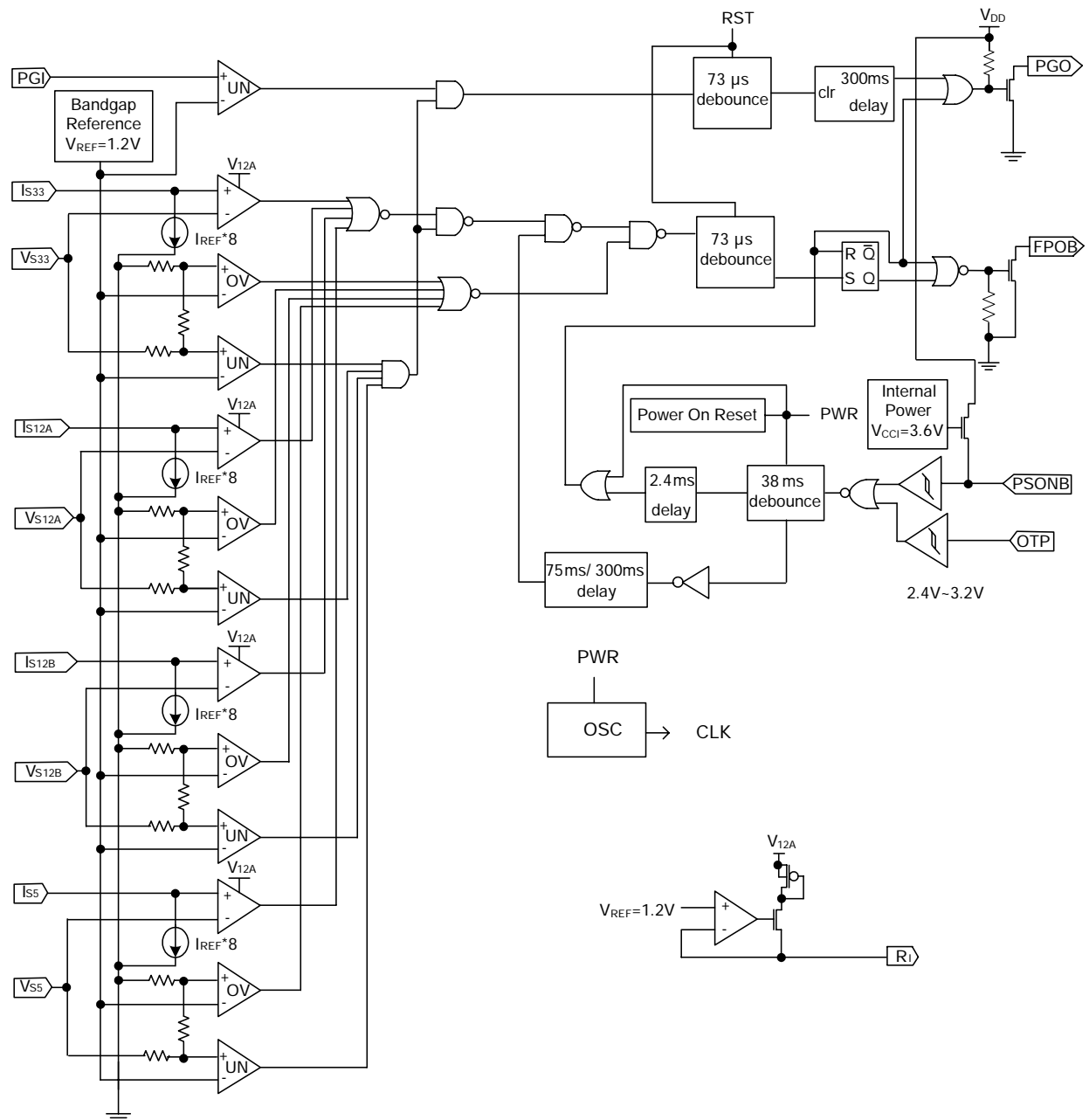

Figure 1. 3513E

■ BLOCK DIAGRAM(Cont.)

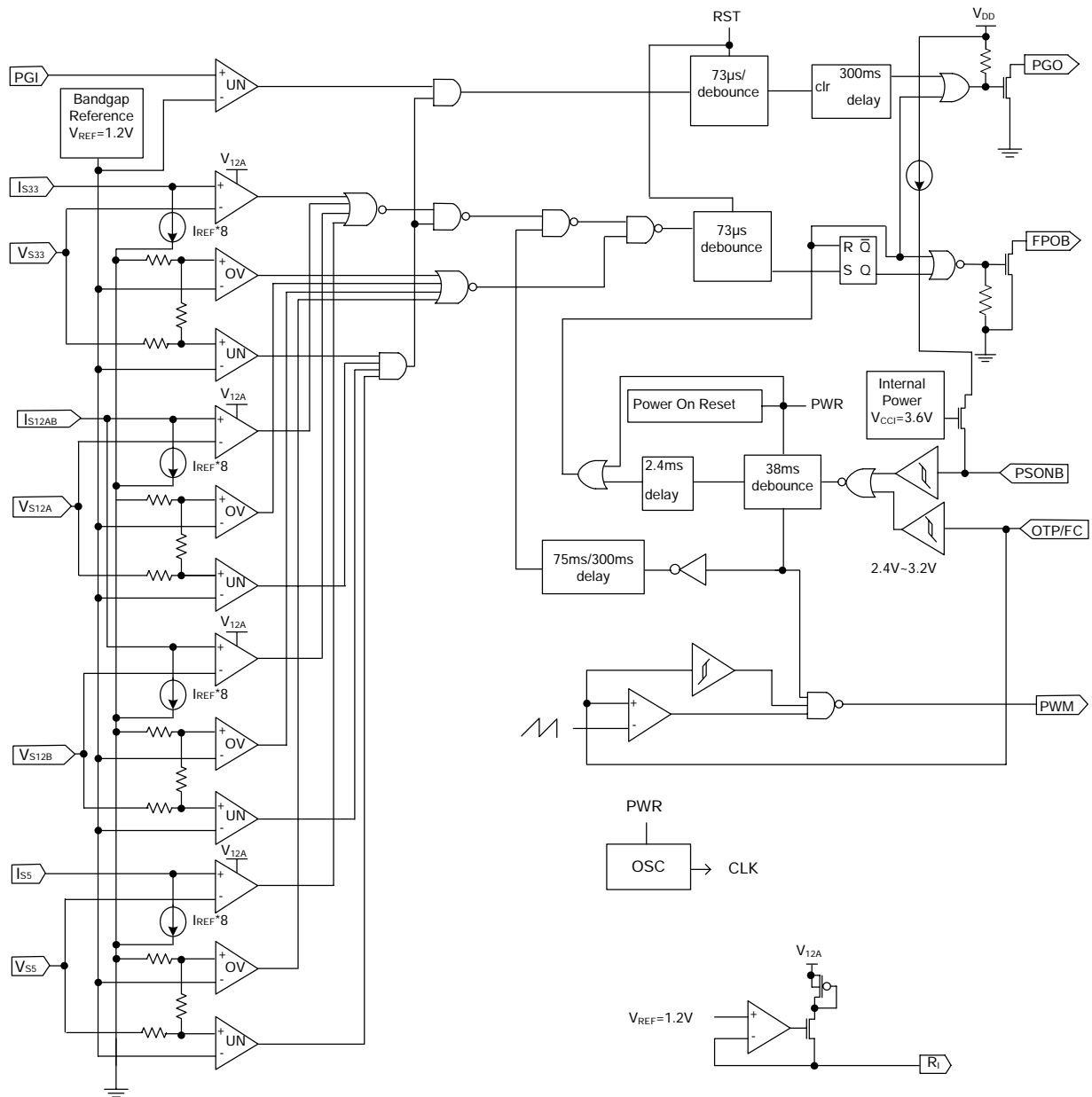

Figure 2. 3513F

■ ABSOLUTE MAXIMUM RATINGS

PARAMETER		SYMBOL	RATINGS	UNIT
Supply Voltage		V_{DD}	-0.3 ~ 16	V
Input Voltage	V_{S5}, V_{S33}	V_{IN}	-0.3 ~ 7	V
	V_{S12A}, V_{S12B}		-0.3 ~ 16	V
	$I_{S12A}, I_{S12B}, I_{S5}, I_{S33}$		-0.3 ~ $V_{12A}+0.3$	V
	PSONB, PGI, OTP		-0.3 ~ 7	V
Output Voltage	FPOB	V_{OUT}	-0.3 ~ $V_{DD}+0.3$	V
	PGO		-0.3 ~ $V_{DD}+0.3$	V
Operating Temperature		T_{OPR}	-40 ~ +125	
Storage Temperature		T_{STG}	-55 ~ +150	

Note 1. Absolute maximum ratings are those values beyond which the device could be permanently damaged.

Absolute maximum ratings are stress ratings only and functional device operation is not implied.

2. Stress above those listed may cause permanent damage to the devices.

■ RECOMMENDED OPERATING CONDITIONS

PARAMETER		SYMBOL	MIN	TYP	MAX	UNIT
Supply Voltage		V_{DD}	4	12	15	V
Input Voltage	V_{S5}, V_{S33}	V_{IN}			7	V
	V_{S12A}, V_{S12B}				15	V
	$I_{S12A}, I_{S12B}, I_{S5}, I_{S33}$				15	V
	PSONB, PGI, OTP				7	V
Output Voltage	FPOB	V_{OUT}			7	V
	PGO				7	V
Output Sink Current	FPOB	$I_{O(SINK)}$			30	mA
	PGO				10	mA
RI Output Current		$I_{O(RI)}$	10		65	uA
Supply Voltage Rising Time (V_{DD})		t_R	1			ms

■ ELECTRICAL CHARACTERISTICS ($T_a=25$ and $V_{DD}=5V$ and $V_{12A}=12V$)

PARAMETER	SYMBOL	TEST CONDITIONS	MIN	TYP	MAX	UNIT
Over Voltage Detection						
Over Voltage Threshold	V_{12A}, V_{12B}		13.2	13.8	14.4	V
	V_5		5.7	5.95	6.2	V
	V_{33}		3.7	3.9	4.1	V
Low Level Output Voltage (FPOB)	V_{OL}	@ $I_{SINK}=10mA$ @ $I_{SINK}=30mA$			0.3 0.7	V
Output Leakage Current (FPOB)	I_{LEAK}	@ $V_{(FPOB)}=5V$			5	uA
PSONB						
High-Level Input Voltage	V_{IH}		2			V
Low-Level Input Voltage	V_{IL}				0.8	V
Input Pull-up Current	I_{IN}	@ PSONB=0V		100		uA
PGI and PGO						
Under Voltage Threshold	V_{12A}, V_{12B}		9.5	9.90	10.5	V
	V_5		4.15	4.30	4.45	V
	V_{33}		2.54	2.68	2.82	V
Input Threshold Voltage (PGI)	$V_{I(THD)}$		1.16	1.20	1.24	V
Low Level Output Voltage (PGO)	V_{OL}	@ $I_{SINK}=10mA$			0.4	V
Output Leakage current (PGO)	I_{LEAK}	@ PGO=5V			5	uA
OTP/FC						
High-Level Input Voltage (OTP)	V_{IH}	3513E/3513F	3.10	3.25	3.40	V
Low-Level Input Voltage (OTP)	V_{IL}		2.30	2.45	2.60	V
Start-up Voltage (FC)			0.7	0.8	0.9	V

■ ELECTRICAL CHARACTERISTICS (Cont.)

PARAMETER	SYMBOL	TEST CONDITIONS	MIN	TYP	MAX	UNIT
Stop Voltage (FC)			0.55	0.65	0.75	V
PWM						
High Level Output Voltage	V_{OH}	@ $I_{SOURCE}=4.5mA$	$V_{12A}-0.4$			V
Low Level Output Voltage	V_{OL}	@ $I_{SINK}=4.5mA$			0.4	V
Output Leakage Current	I_{LEAK}				5	μA
PWM Frequency	f_{PWM}		28	35	42	KHz
SWITCHING CHARACTERISTICS						
PSONB ON (PSONB Low to FPOB Low)	$T_{(PSONB\ ON)}$	@ $V_{DD}=5V$	32	38	62	ms
PSONB OFF (PSONB Hi to PGO Low)	$T_{(PSONB\ OFF)}$	@ $V_{DD}=5V$	32	38	62	ms
PGI to PGO Delay Time	T_{PG}	@ $V_{DD}=5V$	200	300	490	ms
Timing PGO Low to FPO high	T_{PSOFF}	@ $V_{DD}=5V$	2.0	2.4	4	ms
UVD/OCD turn on delay Time	T_{UVP1}	@ FPOB=Low & PGI > 1.2V	65	75	122	ms
	T_{UVP2}	@ FPOB=Low & PGI < 1.2V	260	300	488	ms
Noise Deglitch Time	t_{g1}		63	75	120	μs
Noise Deglitch Time for Latch	t_{g2}		63	75	120	μs
TOTAL DEVICE						
Low Voltage	V_{DD}			3.6		V
Supply Current	I_{DD}	@ PSONB=5V			1	mA

■ APPLICATION CIRCUIT

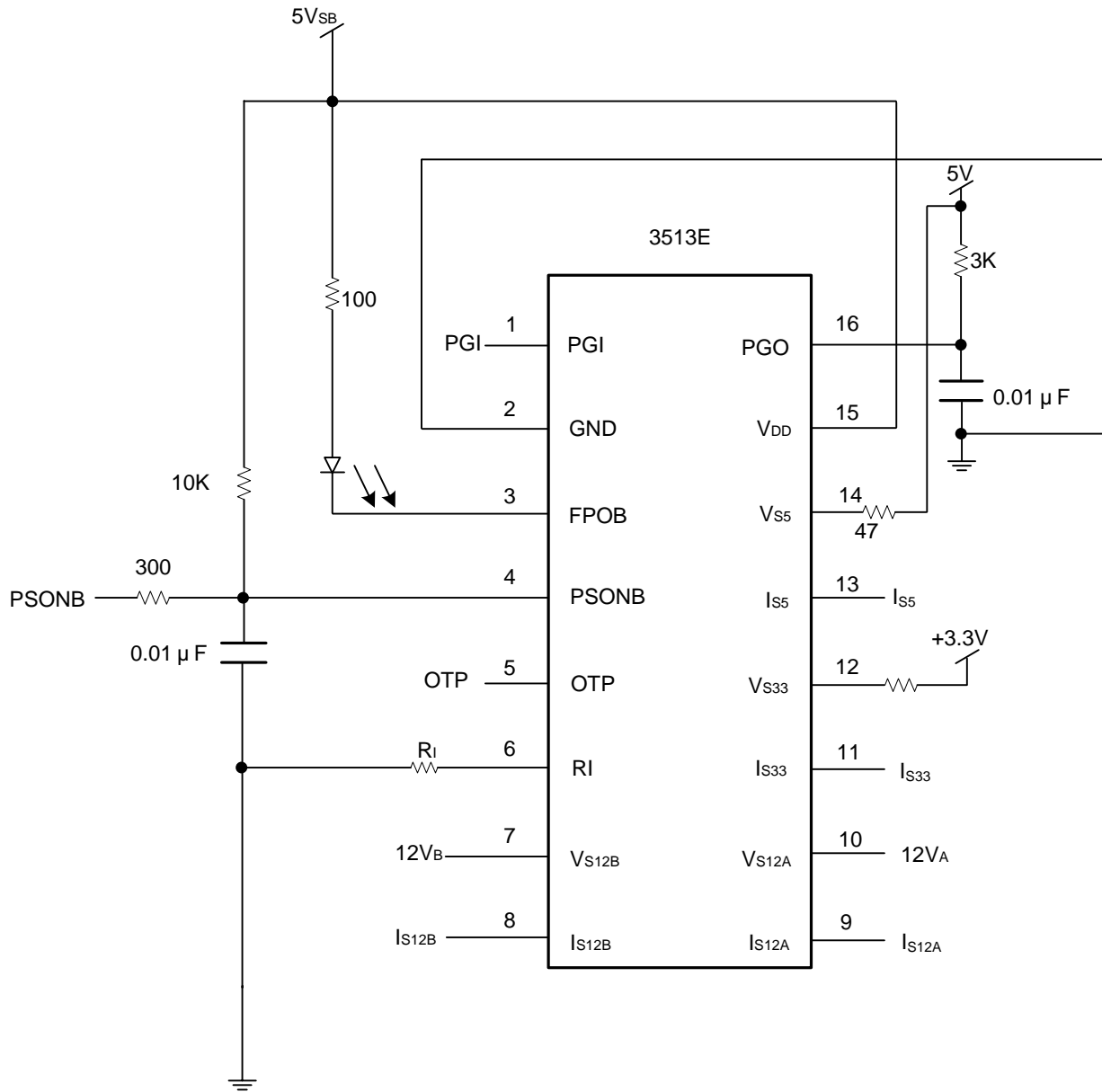

■ APPLICATION CIRCUIT(Cont.)

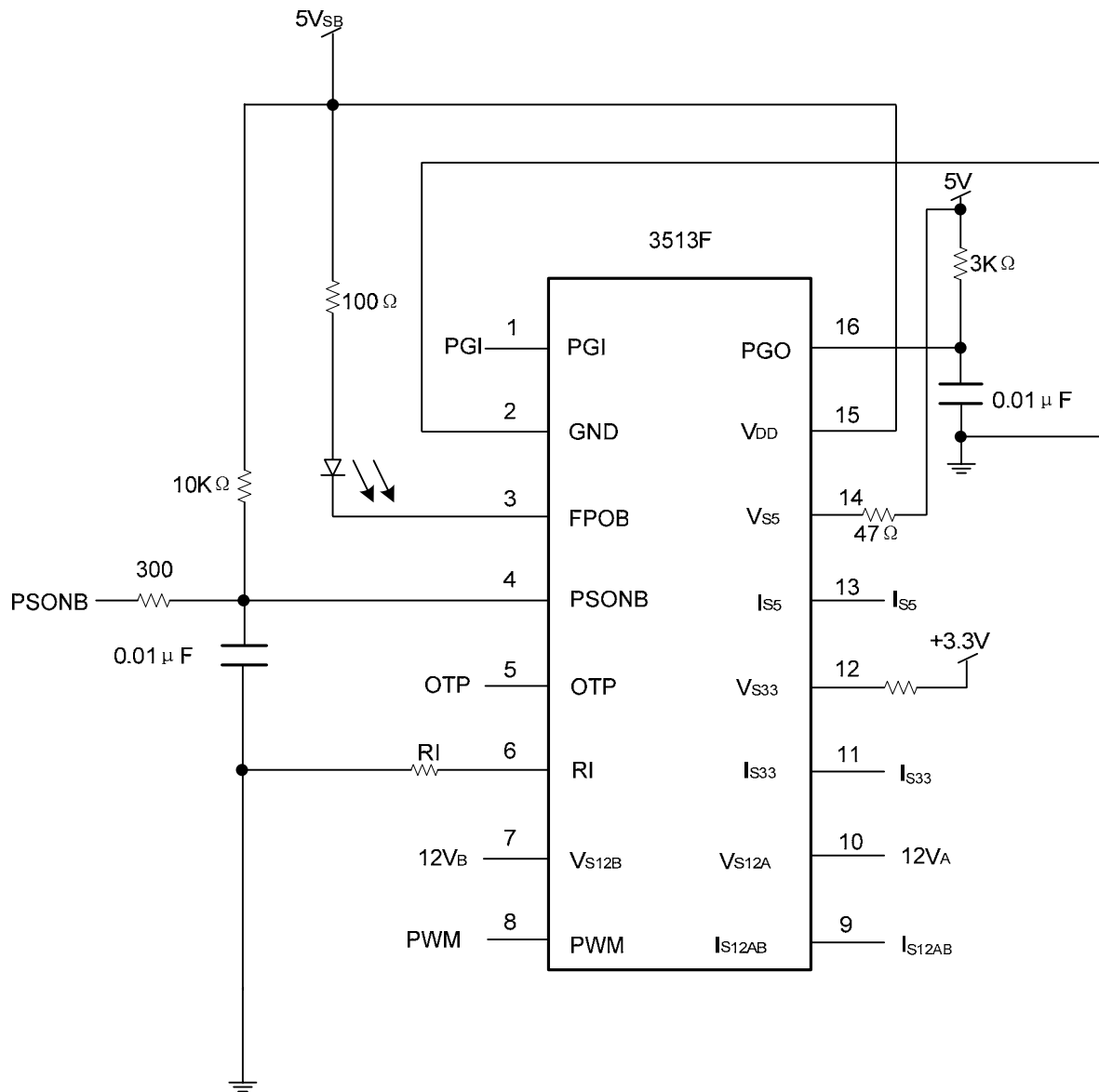

■ TYPICAL TIMMING DIAGRAM

1) PGI (UNDER-VOLTAGE):

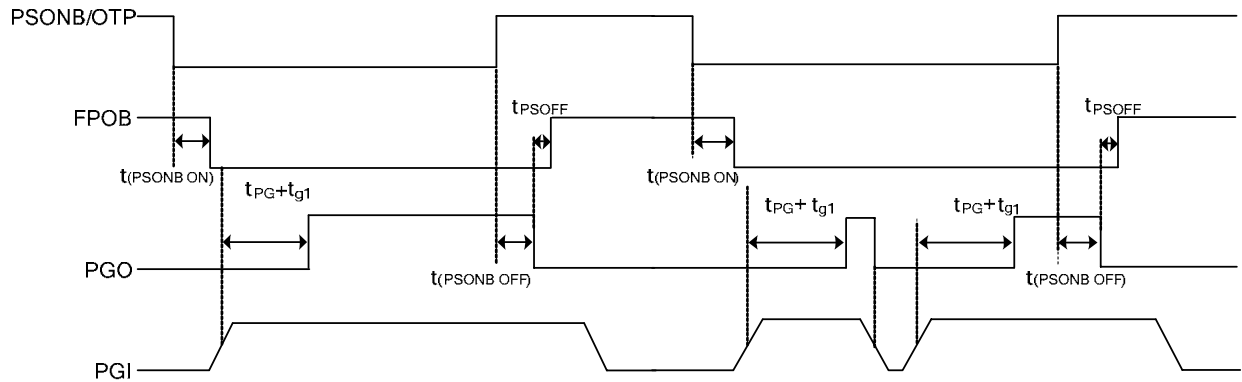

2) V_{33} , V_5 , V_{12A} , V_{12B} (UNDER-VOLTAGE) or I_{S33} , I_{S5} , I_{S12A} , I_{S12B} (OVER-CURRENT):

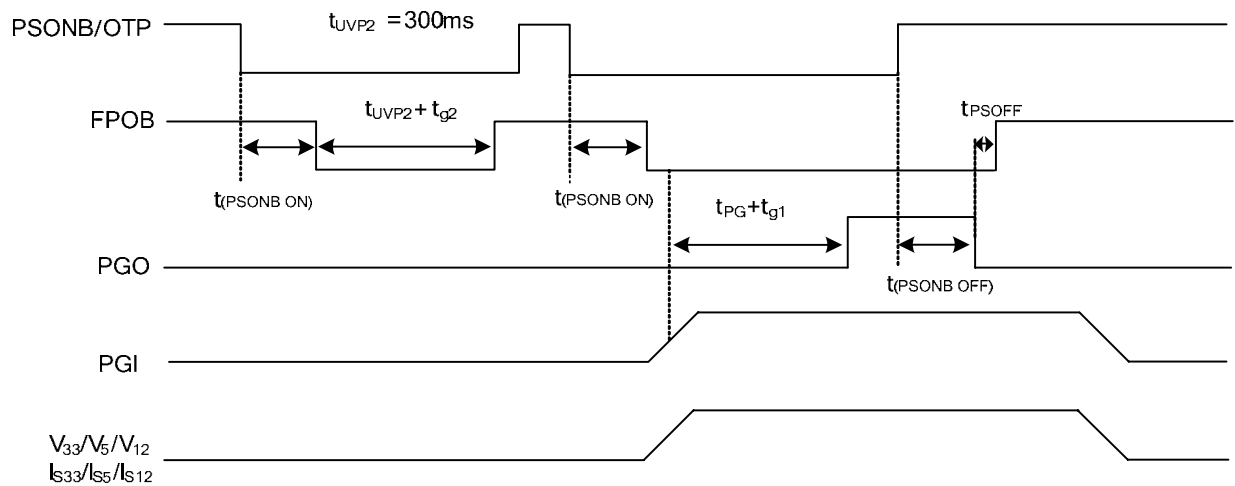
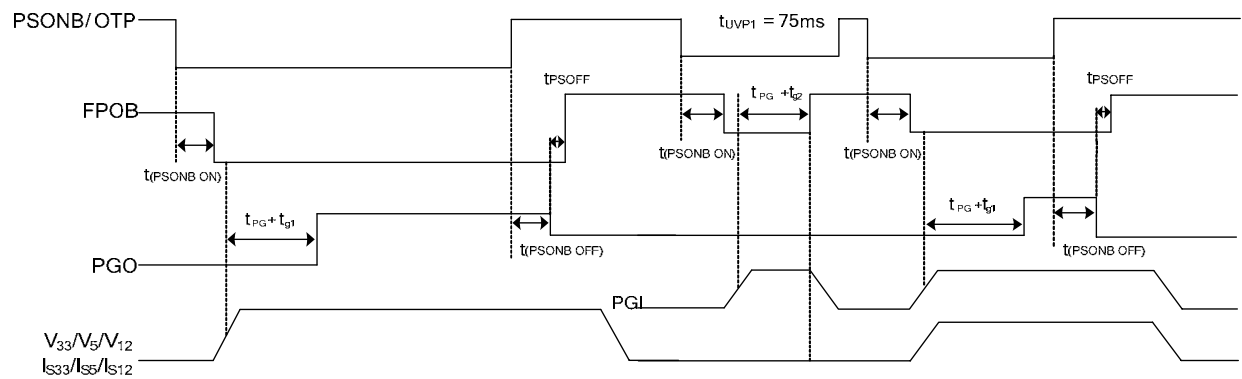

■ TYPICAL TIMMING DIAGRAM

3) V_{33} , V_5 , V_{12A} , V_{12B} (OVER-VOLTAGE).

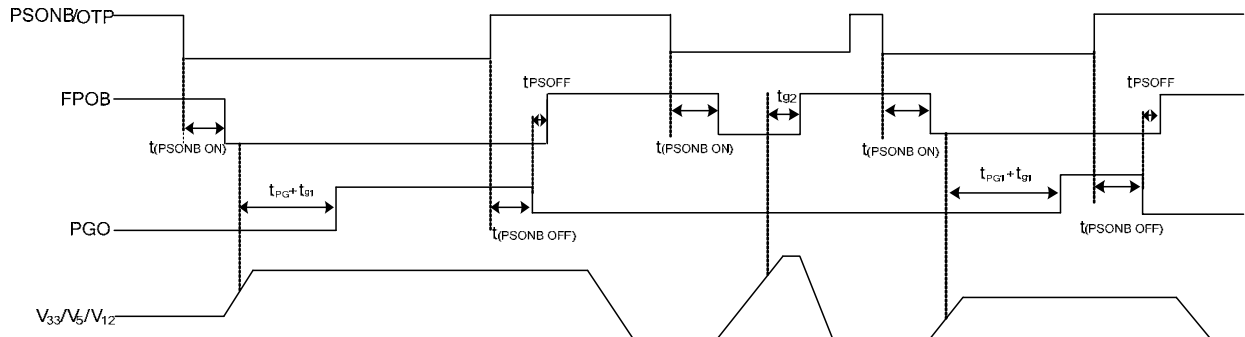

4) OTP/FC, PWM, FPOB:

(at $V_{DD}=5V$, $PSONB=0V$, V_{12A} , $V_{12B} = 12V$, $V_5=5V$, $V_{33}=3.3V$)

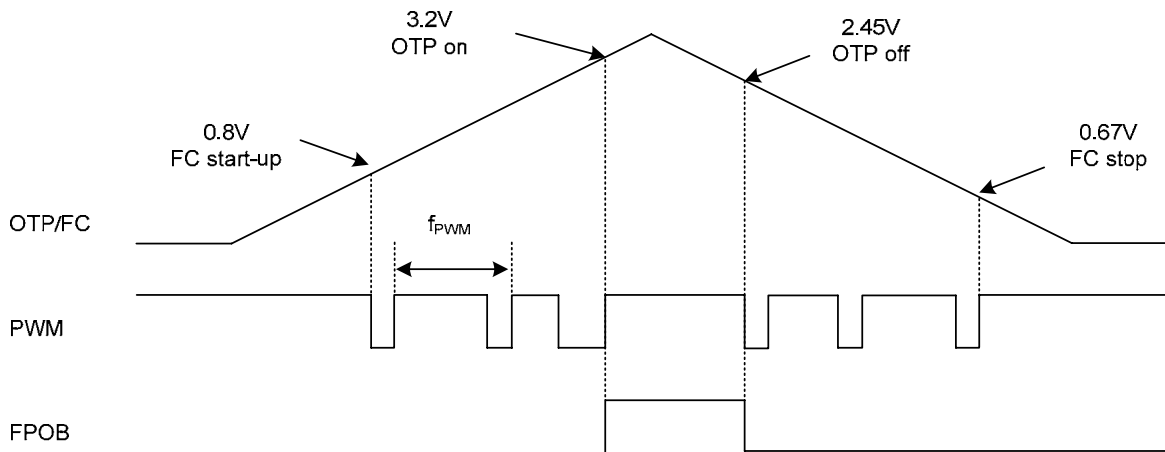

UTC assumes no responsibility for equipment failures that result from using products at values that exceed, even momentarily, rated values (such as maximum ratings, operating condition ranges, or other parameters) listed in products specifications of any and all UTC products described or contained herein. UTC products are not designed for use in life support appliances, devices or systems where malfunction of these products can be reasonably expected to result in personal injury. Reproduction in whole or in part is prohibited without the prior written consent of the copyright owner. The information presented in this document does not form part of any quotation or contract, is believed to be accurate and reliable and may be changed without notice.