

9.9 - 12.5 Gb/s Linear/Limiting Optical Modulator Driver

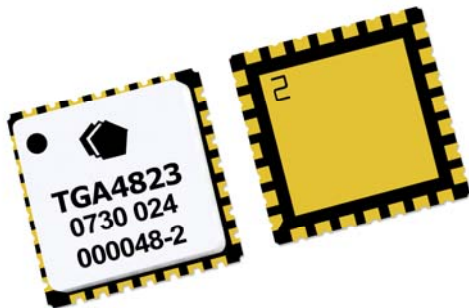

Measured Performance

Bias conditions: $V_d = 8\text{ V}$, $I_d = 310\text{ mA}$, $V_{ctrl} = +1\text{ V}$, $V_g \approx -0.3\text{ V}$ Typical

PRBS = $2^{31}-1$; CPC = 50%, 10.7 GB/s; $V_{in} = 1\text{Vpp}$

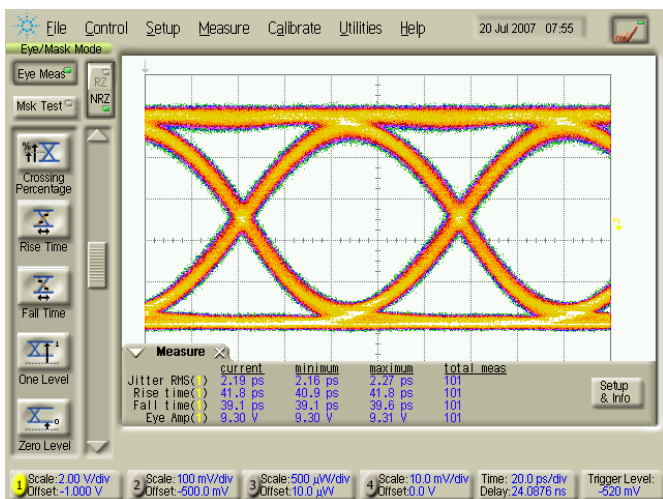

Key Features

- Up to 10 Vpp Linear Output Voltage
- > 12 Vpp Limiting Mode Output Voltage
- Gain: 19 dB
- Internal DC blocks
- Single-ended Input / Output
- Bias: $V_d = 8\text{ V}$, $I_d = 310\text{ mA}$, $V_{ctrl} = +1\text{ V}$, $V_g = -0.3\text{ V}$ Typical for Linear operation
- Package Dimensions: 8 x 8 x 2.1 mm

Primary Applications

- Mach-Zehnder Modulator Driver for Metro and Long Haul

Product Description

The TriQuint TGA4823-SM is part of a series of optical driver amplifiers suitable for a variety of driver applications.

The TGA4823-SM is a medium power wideband AGC amplifier that typically provides 19 dB small signal gain with 19 dB AGC range.

The TGA4823-SM is an excellent choice for applications requiring high drive combined with high linearity. The TGA4823-SM has demonstrated capability to deliver 10Vpp while maintaining output harmonic levels near -30dBc for a 2GHz fundamental.

The TGA4823-SM requires a low frequency choke and control circuitry.

RoHS and Lead-Free compliant. Evaluation boards available on request.

Datasheet subject to change without notice.

Table I
Absolute Maximum Ratings 1/

Symbol	Parameter	Value	Notes
Vd-Vg	Drain to Gate Voltage	12 V	
Vd	Drain Voltage	9 V	2/
Vg	Gate Voltage Range	-5 to 0 V	2/
Vctrl	Control Voltage Range	-1 to +2 V	2/
Id	Drain Current	400 mA	2/
Ig	Gate Current Range	-1.8 to 18.9 mA	
Ictrl	Control Current Range	-1.8 to 18.9 mA	
Pin	Input Continuous Wave Power	27.8 dBm	

- 1/ These ratings represent the maximum operable values for this device. Stresses beyond those listed under "Absolute Maximum Ratings" may cause permanent damage to the device and / or affect device lifetime. These are stress ratings only, and functional operation of the device at these conditions is not implied.
- 2/ Combinations of supply voltage, supply current, input power, and output power shall not exceed the maximum power dissipation listed in Table IV.

Table II
Recommended Linear Operating Conditions

Symbol	Parameter 1/	Value
Vd	Drain Voltage	8 V
Id	Drain Current	310 mA
Id_Drive	Drain Current under RF Drive	350 mA
Vg	Typical Gate Voltage	-0.3 V
Vctrl	Control Voltage	1 V

- 1/ See assembly diagram for bias instructions.

Table III
RF Characterization Table

Bias: Vd = 8 V, Id = 310 mA, Vctrl = +1 V, Vg = -0.3 V, typical

SYMBOL	PARAMETER	TEST CONDITIONS	MIN	NOMINAL	MAX	UNITS
3dB BW	Small Signal 3 dB Bandwidth	Relative to 2 GHz		9.5		GHz
Gain	Small Signal Gain	f = 0.1 – 4 GHz f = 6 GHz f = 8 GHz	- - -	20 19 18	-	dB
IRL	Input Return Loss	f = 0.1 – 10GHz f = 10 – 16 GHz	-	15 9	-	dB
ORL	Output Return Loss	f = 0.1 – 10 GHz f = 10 – 16 GHz	-	15 12	-	dB
Psat	Saturated Output Power	f = 2 GHz	-	26 (12.5)	-	dBm (Vpp)
P1dB	Output Power @ 1dB Compression	f = 2 GHz	-	25	-	dBm
AGC Range	Small Signal AGC Range		-	19	-	dB

Table IV
Power Dissipation and Thermal Properties

Parameter	Test Conditions	Value	Notes
Maximum Power Dissipation	Tbaseplate = 70 °C	Pd = 3.17 W Tchannel = 150 °C Tm = 1.0E+6 Hrs	1/ 2/
Thermal Resistance, θ_{jc}	Vd = 8 V Id = 310 mA Pd = 2.48 W	θ_{jc} = 24.3 (°C/W) Tchannel = 130 °C Tm = 5.8E+6 Hrs	
Thermal Resistance, θ_{jc} Under RF Drive	Vd = 8 V Id = 350 mA Pout = 26.5 dBm Pd = 2.36 W	θ_{jc} = 24.3 (°C/W) Tchannel = 127 °C Tm = 7.6E+6 Hrs	
Mounting Temperature		Refer to Solder Reflow Profiles (pp16)	
Storage Temperature		-65 to 150 °C	

- 1/ For a median life of 1E+6 hours, Power Dissipation is limited to

$$Pd(max) = (150\text{ °C} - Tbase\text{ °C})/\theta_{jc}.$$
- 2/ Channel operating temperature will directly affect the device median time to failure (MTTF). For maximum life, it is recommended that channel temperatures be maintained at the lowest possible levels.

Power De-rating Curve

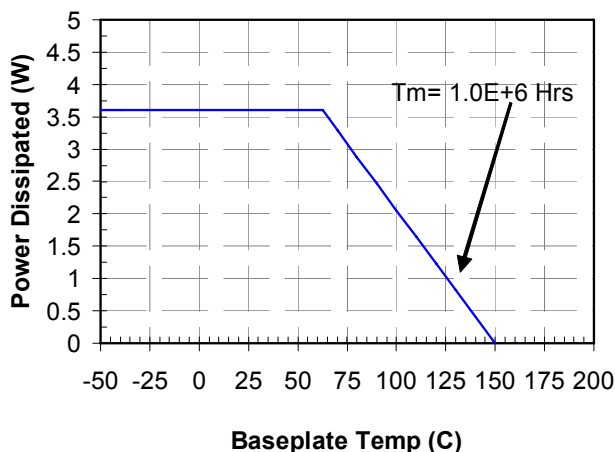

Measured Data

Bias conditions: $V_d = 8\text{ V}$, $I_d = 310\text{ mA}$, $V_{ctrl} = +1\text{ V}$, $V_g \approx -0.3\text{ V}$ Typical

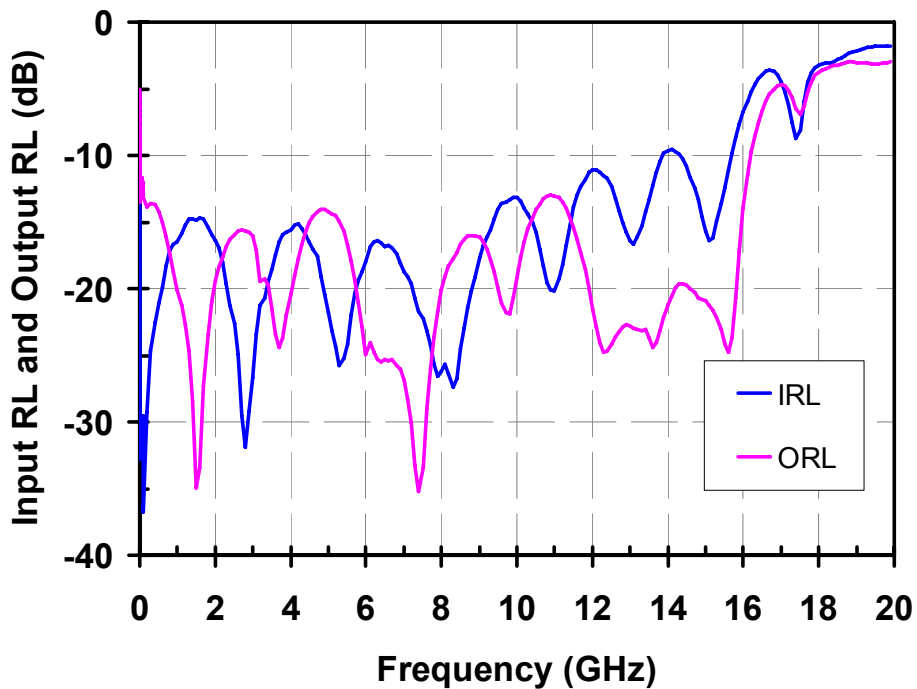
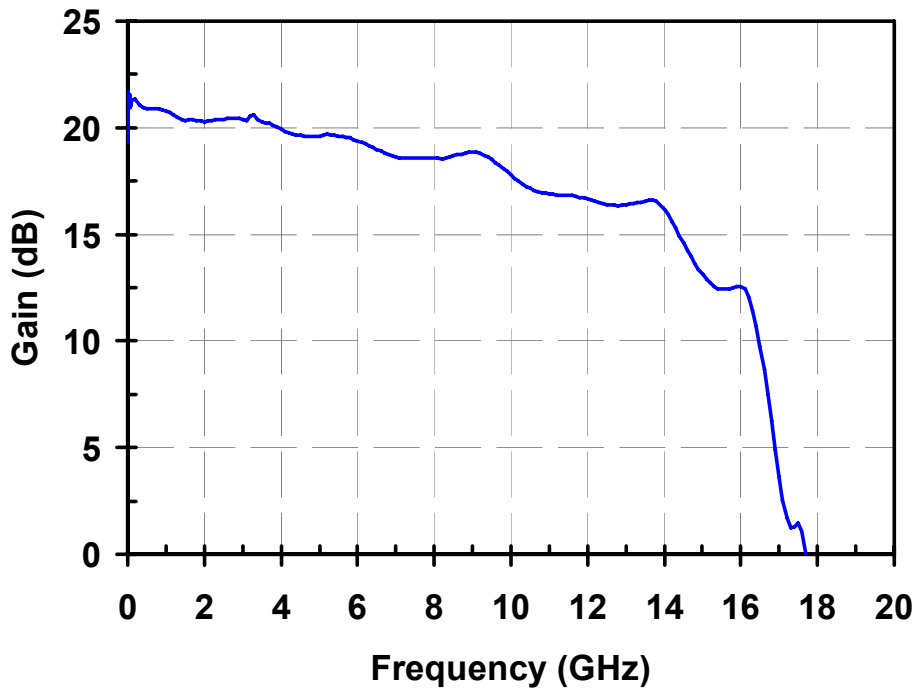

Measured Data

Bias conditions: $V_d = 8\text{ V}$, $I_d = 310\text{ mA}$, $V_{ctrl} = +1\text{ V}$, $V_g \approx -0.3\text{ V}$ Typical

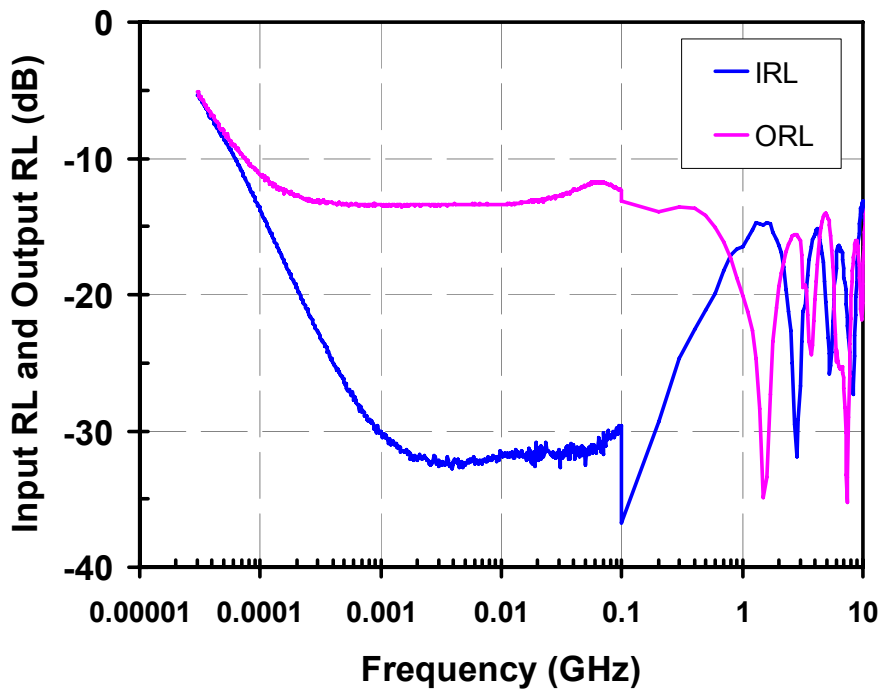
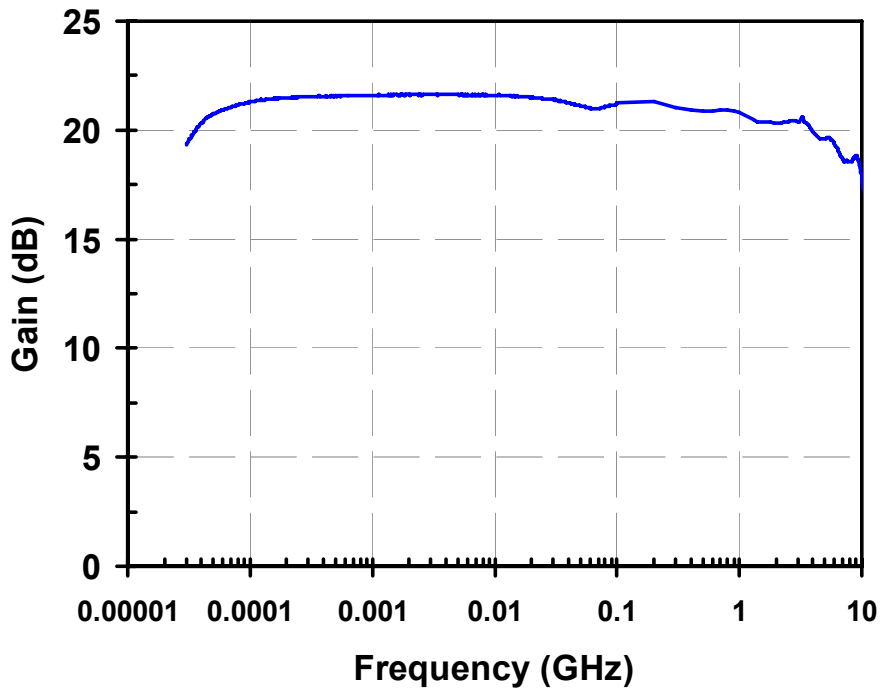

Measured Data

Bias conditions: $V_d = 8\text{ V}$, $I_d = 310\text{ mA}$, $V_{ctrl} = +1\text{ V}$, $V_g \approx -0.3\text{ V}$ Typical

Freq = 2 GHz

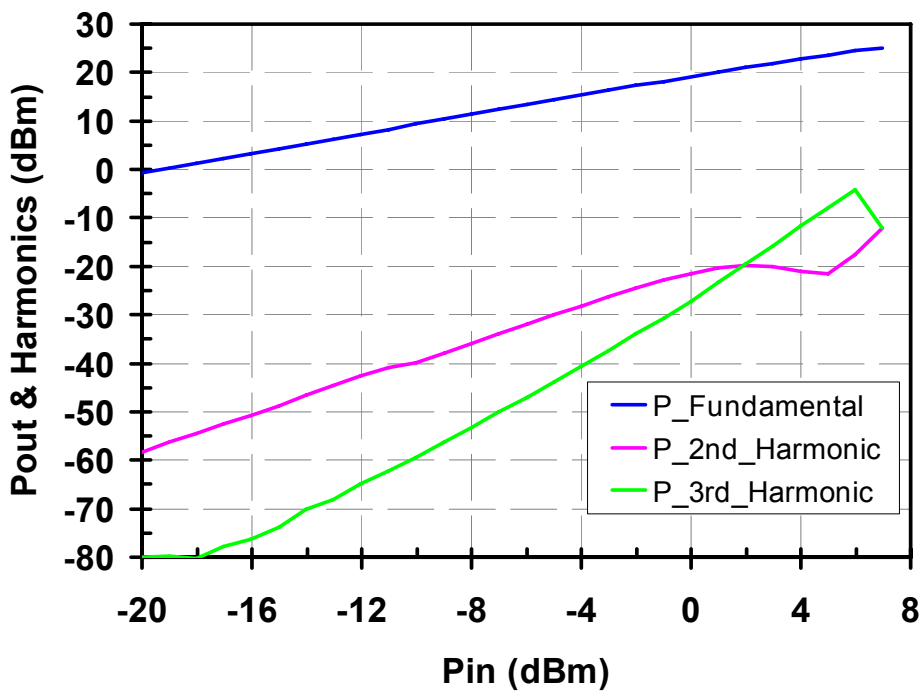
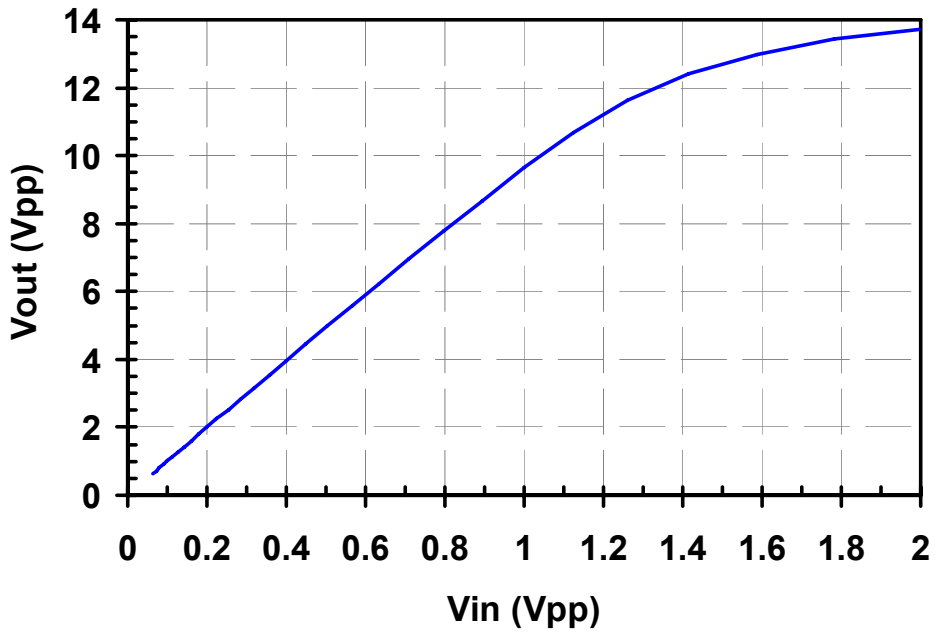

Measured Data

Linear Mode:

Bias conditions: $V_d = 8\text{ V}$, $I_d = 310\text{ mA}$, $V_{ctrl} = +1\text{ V}$, $V_g \approx -0.3\text{ V}$ Typical

PRBS = $2^{31}-1$; CPC = 50%, 10.7 GB/s

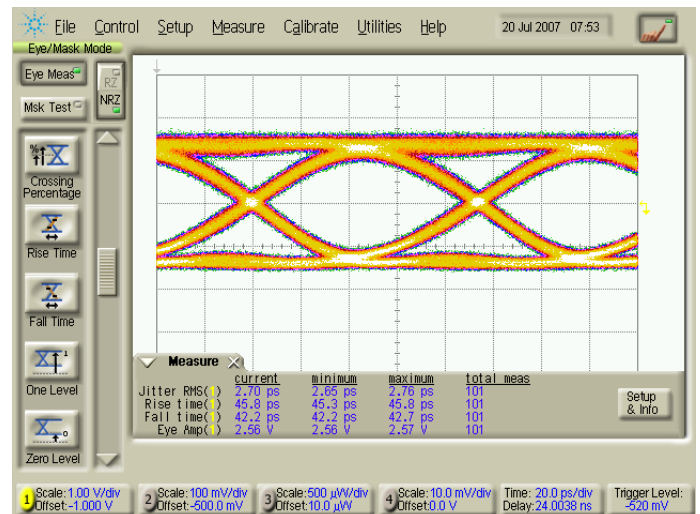
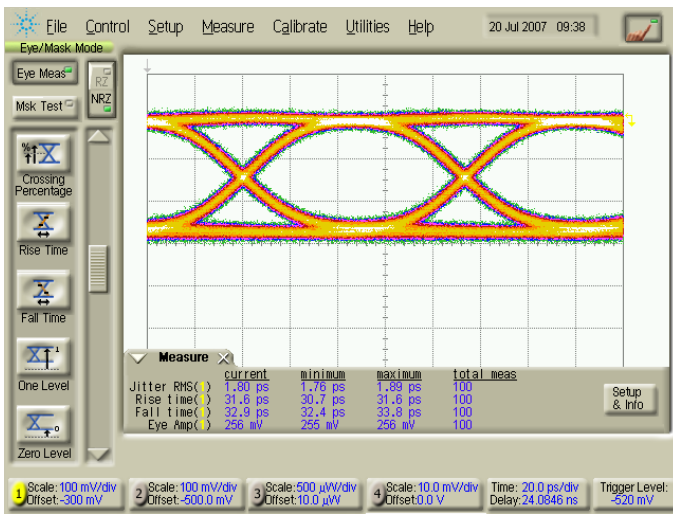

Input Eye: $V_{in} = 250\text{ mV}_{pp}$

Output Eye: $V_{in} = 250\text{ mV}_{pp}$, $V_o = 2.5\text{ V}_{pp}$

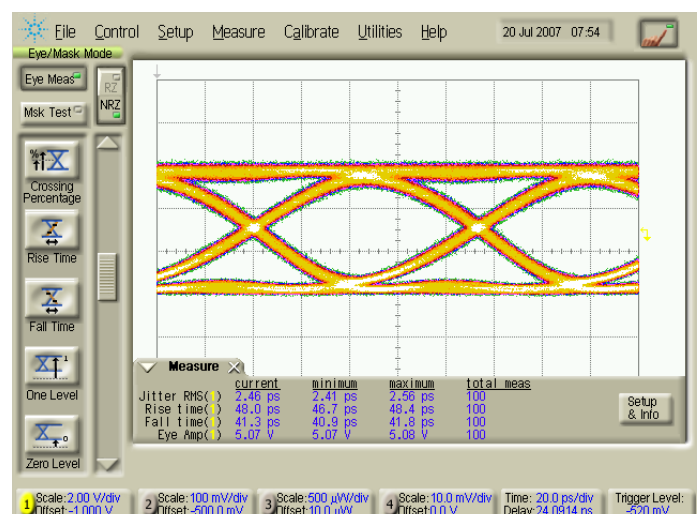
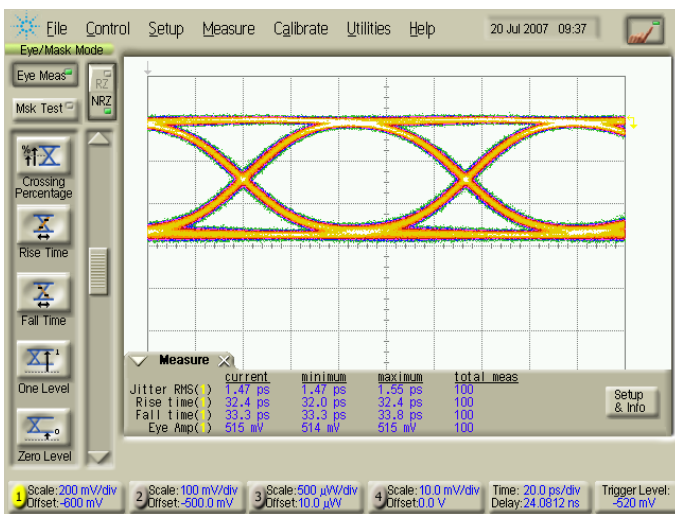

Input Eye: $V_{in} = 500\text{ mV}_{pp}$

Output Eye: $V_{in} = 500\text{ mV}_{pp}$, $V_o = 5\text{ V}_{pp}$

Measured Data

Linear Mode:

Bias conditions: $V_d = 8\text{ V}$, $I_d = 310\text{ mA}$, $V_{ctrl} = +1\text{ V}$, $V_g \approx -0.3\text{ V}$ Typical

PRBS = $2^{31}-1$; CPC = 50%, 10.7 GB/s

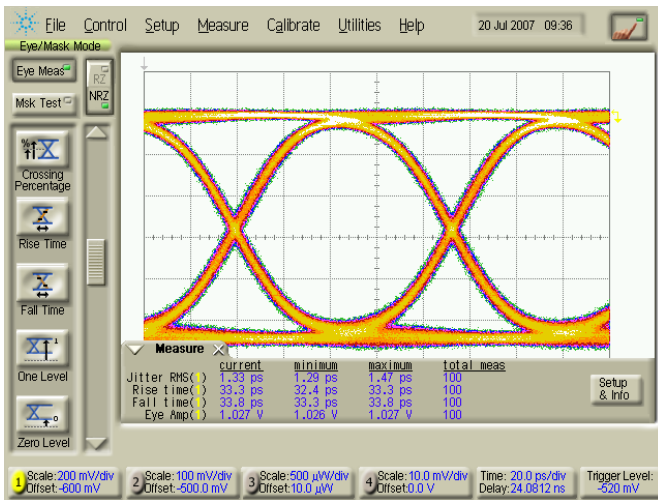

Input Eye: $V_{in} = 1\text{ V}_{pp}$

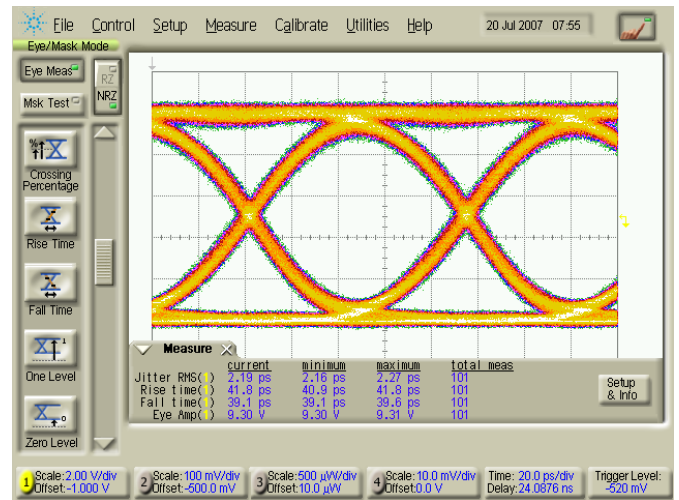

Output Eye: $V_{in} = 1\text{ V}_{pp}$, $V_{o_{pp}} = 9.3\text{ V}_{pp}$

Measured Data

Limiting Mode:

Bias conditions: $V_d = 8\text{ V}$, $I_d = 310\text{ mA}$, $V_{ctrl} = +1\text{ V}$, $V_g \approx -0.3\text{ V}$ Typical

PRBS = $2^{31}-1$; CPC = 50%, 10.7 GB/s

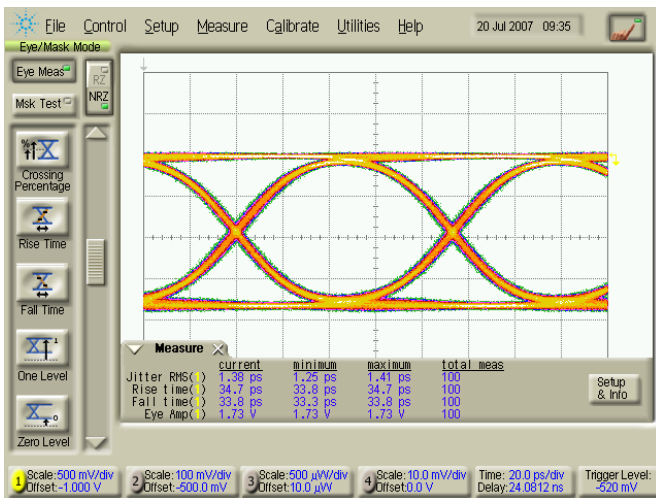

Input Eye: $V_{in} = 1700\text{ mV}_{pp}$

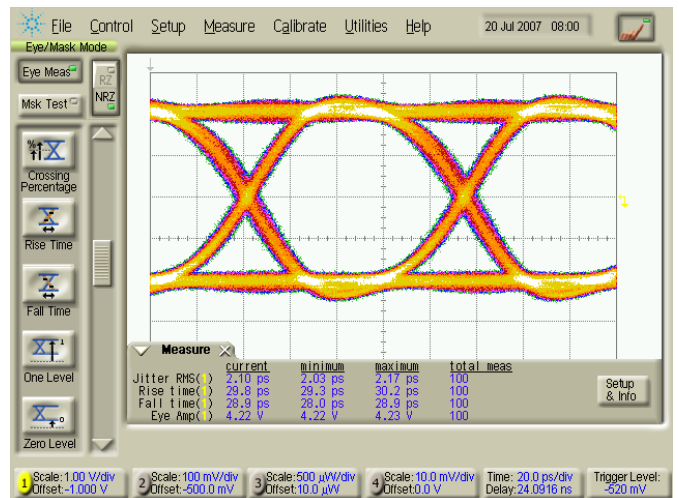

Output Eye: $V_{in} = 1700\text{ V}_{pp}$, $V_{o pp} = 4.2\text{ V}_{pp}$

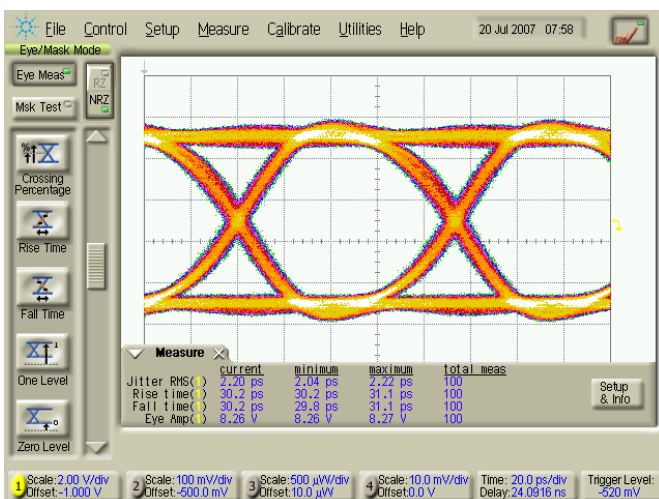

Output Eye: $V_{in} = 1700\text{ V}_{pp}$, $V_{o pp} = 8.3\text{ V}_{pp}$

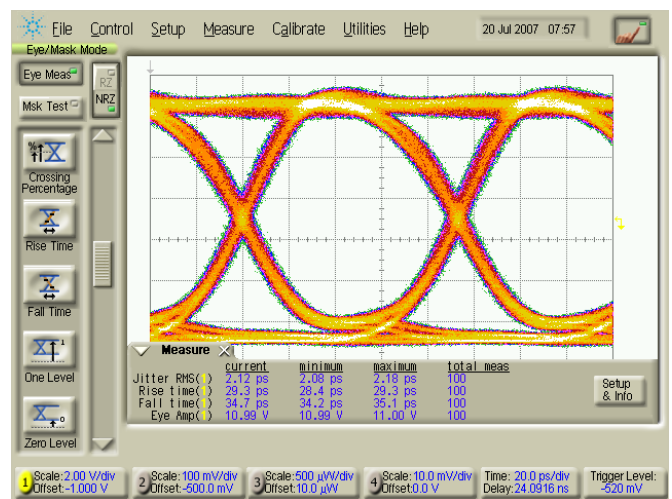

Output Eye: $V_{in} = 1700\text{ V}_{pp}$, $V_{o pp} = 11\text{ V}_{pp}$

Electrical Schematic

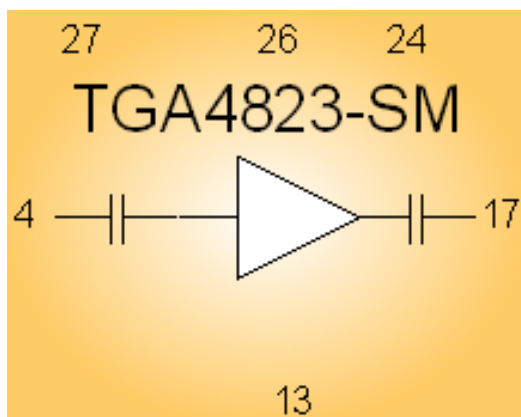

Bias Procedures

V_d=8V, CPC=50%

Bias ON

1. Disable the output of the PPG
2. Set $V_D = 0V$, $V_{CTRL} = 0V$ & $V_G = 0V$
3. Set $V_G = -1.5V$
4. Increase V_D to 8V observing I_D
- Assure $I_D = 0mA$
5. Set $V_{CTRL} = +1V$
- I_D should still be 0mA
6. Make V_G more positive until $I_D = 310mA$.
 V_G will be approximately -0.3V.
7. Enable the output of the PPG.
8. Output Swing Adjust: Adjust V_{CTRL} slightly positive to increase output swing or adjust V_{CTRL} slightly negative to decrease the output swing.
9. Crossover Adjust: Adjust V_G slightly positive to push the crossover down or adjust V_G slightly negative to push the crossover up.

Bias OFF

1. Disable the output of the PPG
2. Set $V_{CTRL} = 0V$
3. Set $V_D = 0V$
4. Set $V_G = 0V$

Recommended Application Circuit

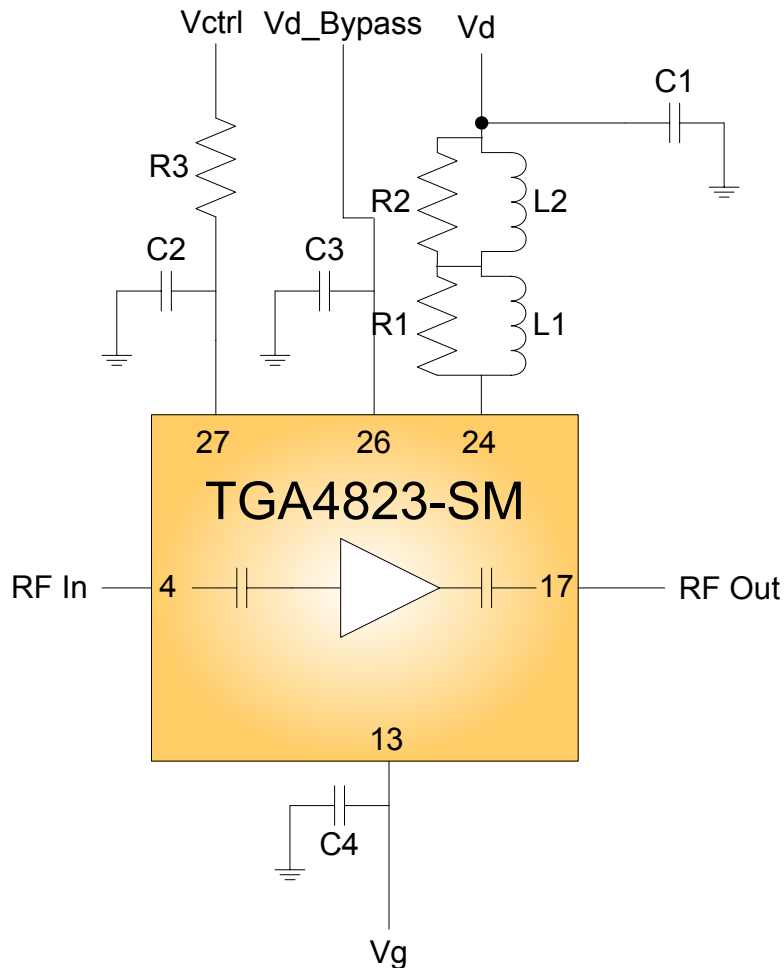

Label	Value	Part Number	Vendor
L1	330nH	ELJ-FAR33MF2	Panasonic
L2	220uH	ELL-CTV221M	Panasonic
R1,R2	270 Ohm	ERJ-3GEYJ271V	Panasonic
R3	620 Ohm	ERJ-3GEYJ621V	Panasonic
C1	10uF	TAJA106K016R	AVX
C2,C3	1uF	0603YG105ZAT2A	AVX
C4	10uF	GRM188R60J106ME47D	Murata
U1		TGA4823-SM	TriQuint

** Note: For Hot-Pluggable option, R3 is limited to Rx ohms,
for a maximum Vctrl_user such that Vctrl pin on package does not exceed + 2 V
Where $R_x = (Vctrl_user - Vctrl_pin) / Ictrl_max = (Vctrl_user - 2V) / 18.9\text{ mA}$

GaAs MMIC devices are susceptible to damage from Electrostatic Discharge. Proper precautions should be observed during handling, assembly and test.

Recommended Assembly Diagram

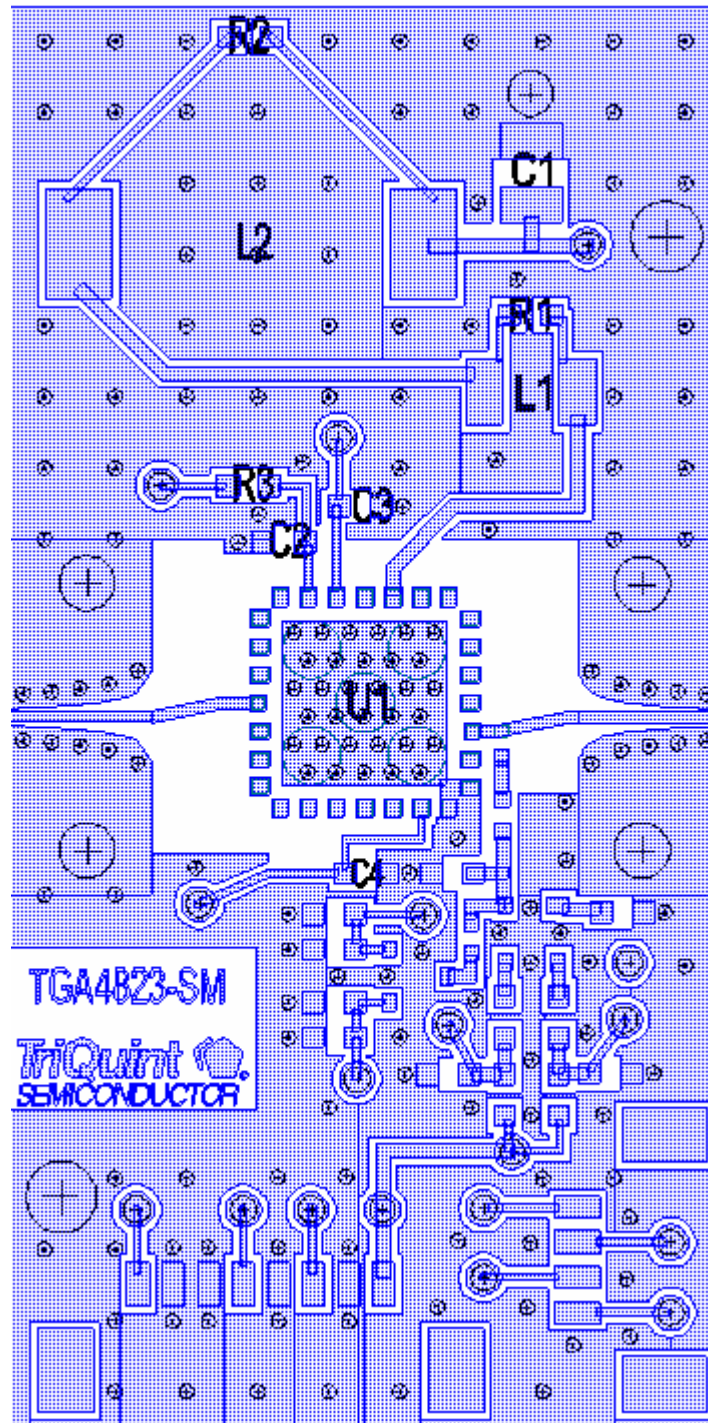

GaAs MMIC devices are susceptible to damage from Electrostatic Discharge. Proper precautions should be observed during handling, assembly and test.

Package Pinout

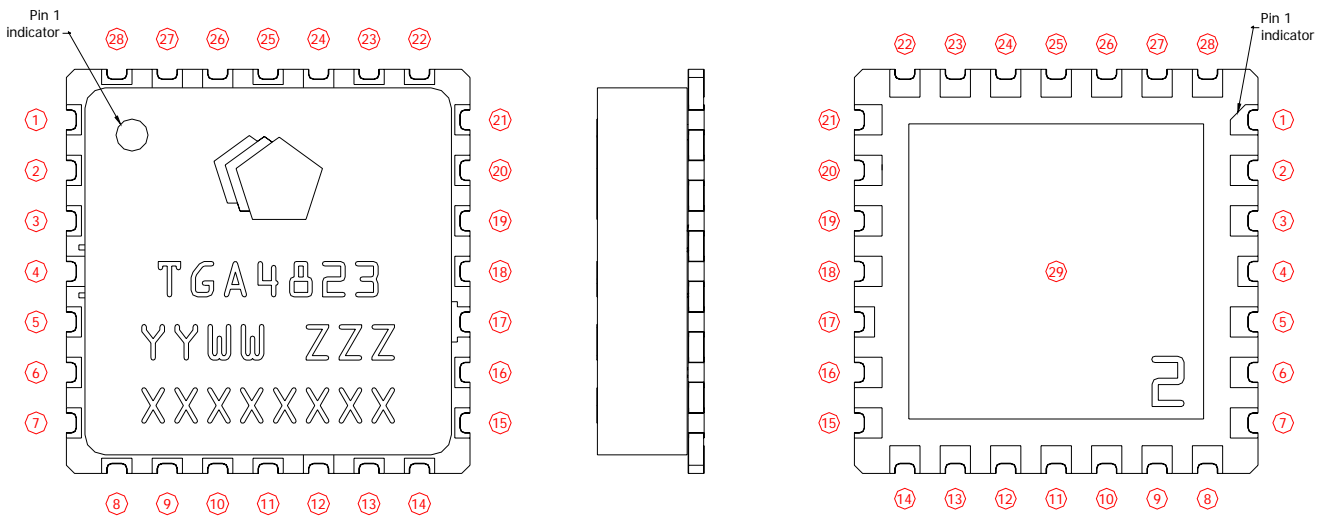

Pin	Description
1,2,3,5,6,7,8,9,10, 11,13,14,15,16,18, 19,20,21,22, 23,25,28	N/C
4	RF In
12	Vg
17	RF Out
24	Vd
26	Vd_Bypass
27	Vctrl
29	GND

Mechanical Drawing

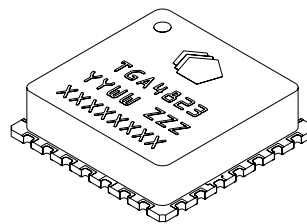
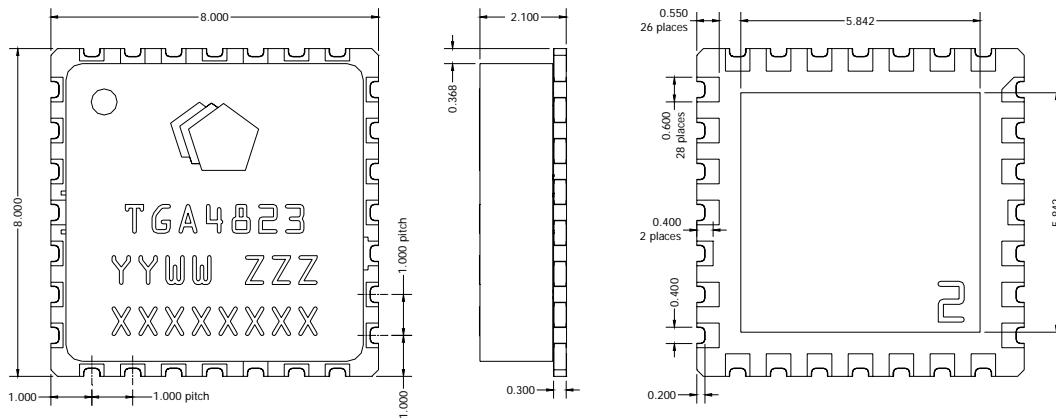

Isometric View
SCALE 10 : 1

Units: millimeters

Unless specified otherwise, tolerances: ± 0.100

Materials:

Package base	Aluminum Nitride (AlN)
Package lid	White Alumina (Al ₂ O ₃)

Pad finish on package base:

Electroless gold (Au)	0.5 – 1.0 um
Over	
Electroless nickel (Ni)	2.0 um min.

GaAs MMIC devices are susceptible to damage from Electrostatic Discharge. Proper precautions should be observed during handling, assembly and test.

Assembly Notes

Recommended Surface Mount Package Assembly

- Proper ESD precautions must be followed while handling packages.
- Clean the board with acetone. Rinse with alcohol. Allow the circuit to fully dry.
- TriQuint recommends using a conductive solder paste for attachment. Follow solder paste and reflow oven vendors' recommendations when developing a solder reflow profile. Typical solder reflow profiles are listed in the table below.
- Hand soldering is not recommended. Solder paste can be applied using a stencil printer or dot placement. The volume of solder paste depends on PCB and component layout and should be well controlled to ensure consistent mechanical and electrical performance.
- Clean the assembly with alcohol.

Typical Solder Reflow Profiles

Reflow Profile	SnPb	Pb Free
Ramp-up Rate	3 °C/sec	3 °C/sec
Activation Time and Temperature	60 – 120 sec @ 140 – 160 °C	60 – 180 sec @ 150 – 200 °C
Time above Melting Point	60 – 150 sec	60 – 150 sec
Max Peak Temperature	240 °C	260 °C
Time within 5 °C of Peak Temperature	10 – 20 sec	10 – 20 sec
Ramp-down Rate	4 – 6 °C/sec	4 – 6 °C/sec

Ordering Information

Part	Package Style
TGA4823-SM	8x8 Surface Mount

GaAs MMIC devices are susceptible to damage from Electrostatic Discharge. Proper precautions should be observed during handling, assembly and test.