

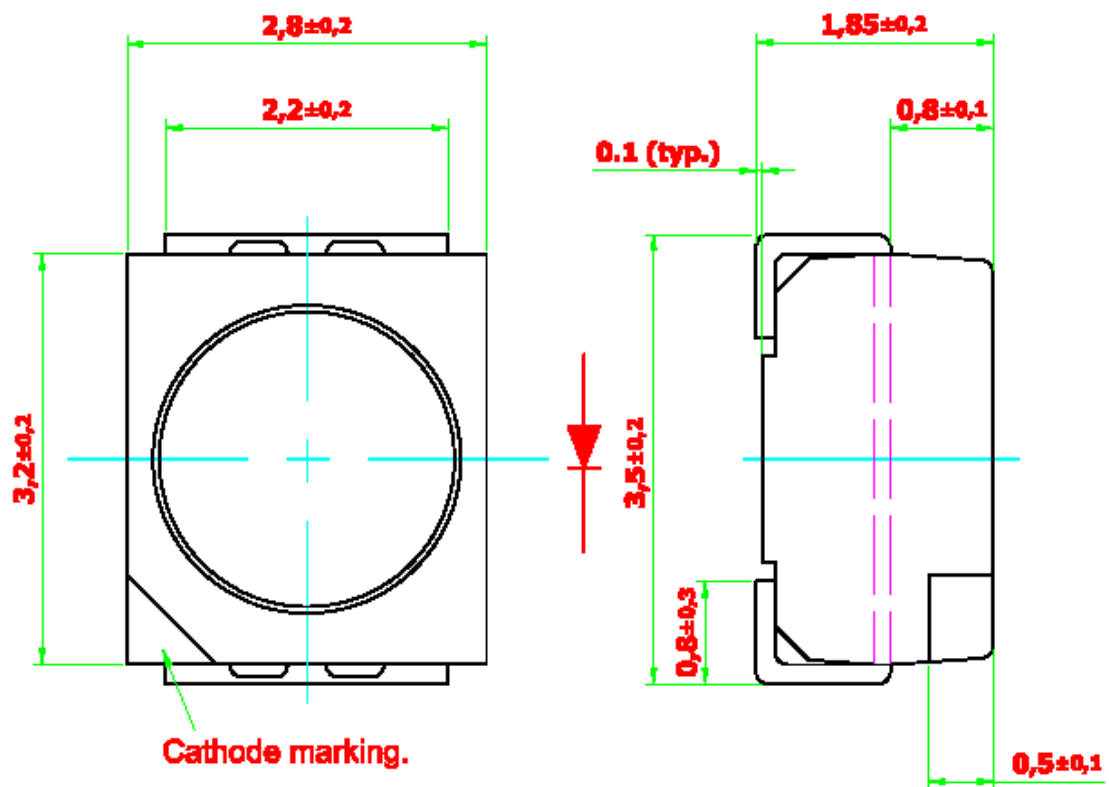

## DomiLED InGaN



- High brightness surface mount LED.
- Based on InGaN technology.
- 120° viewing angle.
- Small package outline (LxWxH) of 2.8 x 3.2 x 1.8 mm.
- Qualified according to JEDEC moisture sensitivity Level 2.
- Compatible to both IR reflow soldering and TTW soldering.



Part Ordering Number	Chip Technology / Color	Viewing angle	Luminous Intensity @ If = 20mA Iv ( mcd )
• • • •	InGaN / Blue, 470 nm	120	<b>45.0 ... 112.5</b> 45.0 ... 56.0 56.0 ... 71.5 71.5 ... 90.0 90.0 ... 112.5
• • • •			<b>71.5 ... 180.0</b> 71.5 ... 90.0 90.0 ... 112.5 112.5 ... 140.0 140.0 ... 180.0
• • •			<b>112.5 ... 224.0</b> 112.5 ... 140.0 140.0 ... 180.0 180.0 ... 224.0
• • • •	InGaN / Cyan, 505 nm	120	<b>112.5 ... 285.0</b> 112.5 ... 140.0 140.0 ... 180.0 180.0 ... 224.0 224.0 ... 285.0
• • • •			<b>180.0 ... 450.0</b> 180.0 ... 224.0 224.0 ... 285.0 285.0 ... 355.0 355.0 ... 450.0
• • •			<b>285.0 ... 560.0</b> 285.5 ... 355.0 355.0 ... 450.0 450.0 ... 560.0



Part Ordering Number	Chip Technology / Color	Viewing angle	Luminous Intensity @ If = 20mA Iv ( mcd )
• • • •	InGaN / True Green, 525 nm	120	<b>112.5 ... 285.0</b> 112.5 ... 140.0 140.0 ... 180.0 180.0 ... 224.0 224.0 ... 285.0  <b>180.0 ... 450.0</b> 180.0 ... 224.0 224.0 ... 285.0 285.0 ... 355.0 355.0 ... 450.0  <b>285.0 ... 715.0</b> 285.0 ... 355.0 355.0 ... 450.0 450.0 ... 560.0 560.0 ... 715.0
• • • •  • • •  • • • •  • • • •  • • • •	InGaN / White	120	<b>112.5 ... 285.0</b> 112.5 ... 140.0 140.0 ... 180.0 180.0 ... 224.0 224.0 ... 285.0  <b>180.0 ... 355.0</b> 180.0 ... 224.0 224.0 ... 285.0 285.0 ... 355.0  <b>180.0 ... 450.0</b> 180.0 ... 224.0 224.0 ... 285.0 285.0 ... 355.0 355.0 ... 450.0  <b>285.0 ... 715.0</b> 285.0 ... 355.0 355.0 ... 450.0 450.0 ... 560.0 560.0 ... 715.0  <b>450.0 ... 900.0</b> 450.0 ... 560.0 560.0 ... 715.0 715.0 ... 900.0



Part Ordering Number	Chip Technology / Color	Viewing angle	Luminous Intensity @ If = 20mA Iv ( mcd )
▪ ▪ ▪			560.0 ... 1125.0  560.0 ... 715.0 715.0 ... 900.0 900.0 ... 1125.0

NOTE:

1. All part number above comes in a quantity of 2000 units per reel.
2. Other luminous intensity groups are also available upon request.
3. Luminous intensity is measured with an accuracy of  $\pm 11\%$ .
4. Wavelength binning is carried for all units as per the wavelength-binning table. Only one wavelength group is allowed for each reel.
5. An optional Vf binning is also available upon request. Binning scheme is as per following table.

**Electrical Characteristics at Ta=25°C.**

Part Number	Vf @ If = 20mA			Vr @ Ir = 10uA
	Min. (V)	Typ. (V)	Max. (V)	Min.(V)
	3.0 & 2.9 *	3.2	3.8	5
	3.0	3.4	4.0	5

Forward voltage, Vf is measured with an accuracy of  $\pm 0.1$  V.



**Wavelength Grouping.**

Color	Group	Wavelength distribution (nm)
	Full	464 - 476
	W	464 - 468
	X	468 - 472
	Y	472 - 476
	Full	499 - 511
	W	499 - 503
	X	503 - 507
	Y	507 - 511
	Full	520 - 536
	W	520 - 524
	X	524 - 528
	Y	528 - 532
	Z	532 - 536

Dominant wavelength is measured with an accuracy of  $\pm 1$  nm.

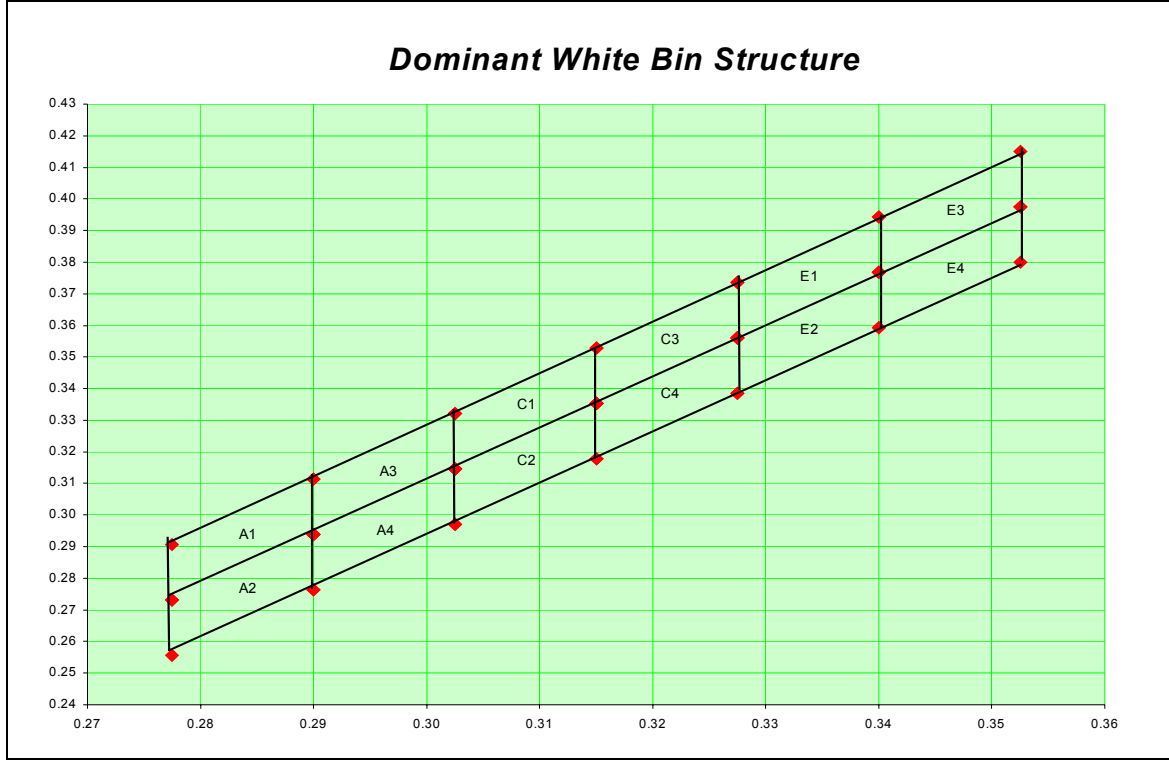

Chromaticity coordinate groups are measured with an accuracy of  $\pm 0.01$ .

Bin	W					Bin	X				
A1	Cx	0.2775	0.2900	0.2900	0.2775	E1	Cx	0.3275	0.3400	0.3400	0.3275
	Cy	0.2732	0.2939	0.3114	0.2907		Cy	0.3561	0.3768	0.3943	0.3736
A2	Cx	0.2775	0.2900	0.2900	0.2775	E2	Cx	0.3275	0.3400	0.3400	0.3275
	Cy	0.2557	0.2764	0.2939	0.2732		Cy	0.3386	0.3593	0.3768	0.3561
A3	Cx	0.2900	0.3025	0.3025	0.2900	E3	Cx	0.3400	0.3525	0.3525	0.3400
	Cy	0.2939	0.3146	0.3321	0.3114		Cy	0.3768	0.3975	0.4150	0.3943
A4	Cx	0.2900	0.3025	0.3025	0.2900	E4	Cx	0.3400	0.3525	0.3525	0.3400
	Cy	0.2764	0.2971	0.3146	0.2939		Cy	0.3593	0.3800	0.3975	0.3768
C1	Cx	0.3025	0.3150	0.3150	0.3025						
	Cy	0.3146	0.3354	0.3529	0.3321						
C2	Cx	0.3025	0.3150	0.3150	0.3025						
	Cy	0.2971	0.3179	0.3354	0.3146						
C3	Cx	0.3150	0.3275	0.3275	0.3150						
	Cy	0.3354	0.3561	0.3736	0.3529						
C4	Cx	0.3150	0.3275	0.3275	0.3150						
	Cy	0.3179	0.3386	0.3561	0.3354						



**Vf Binning (Optional).**

<b>Vf Bin @ 20mA</b>	<b>Forward voltage (V)</b>
00	3.05 ... 3.35
01	3.35 ... 3.65
02	3.65 ... 3.95
03	3.95 ... 4.25

Forward voltage, Vf is measured with an accuracy of  $\pm 0.1$  V.

**Absolute Maximum Ratings.**

	<b>Maximum Value</b>	<b>Unit</b>
DC forward current.	20	mA
Peak pulse current; ( $t_p \leq 10 \mu s$ , Duty cycle = 0.005)	200	mA
Reverse voltage.	5	V
ESD Threshold (HBM)	2000	V
LED junction temperature.	125	$^{\circ}C$
Operating temperature.	-40 ... +100	$^{\circ}C$
Storage temperature.	-40 ... +100	$^{\circ}C$
Power dissipation ( at room temperature )	85	mW



**Recommended Solder Pad**

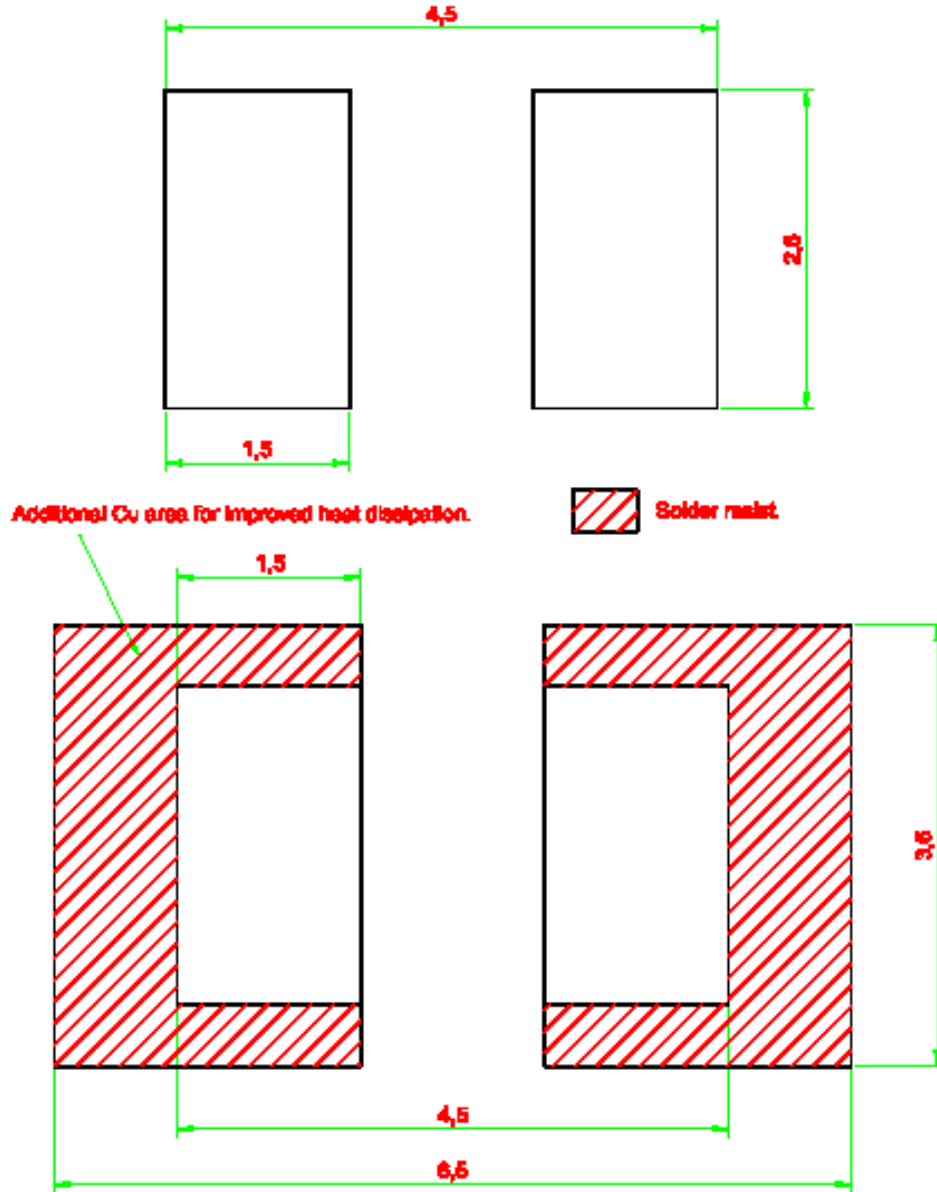





**Relative luminous intensity vs. forward current.**

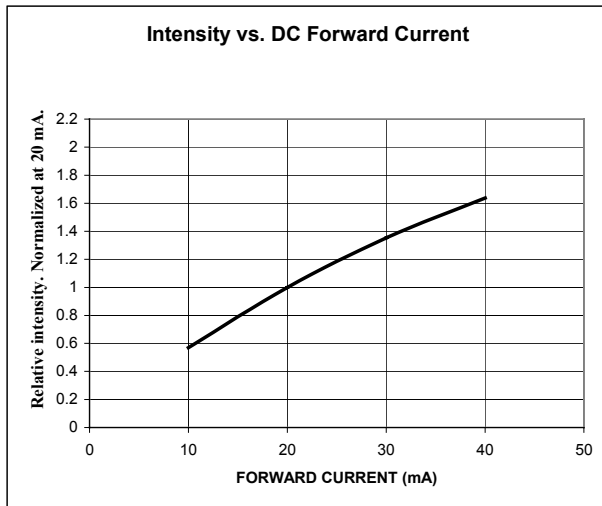

**Forward current vs. forward voltage.**

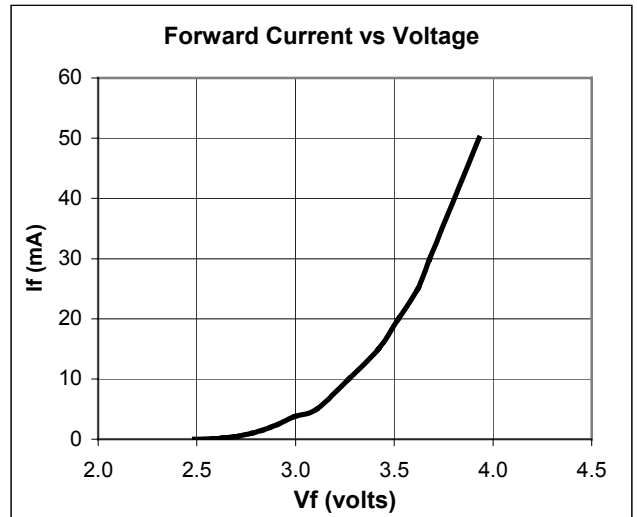

**Radiation pattern.**

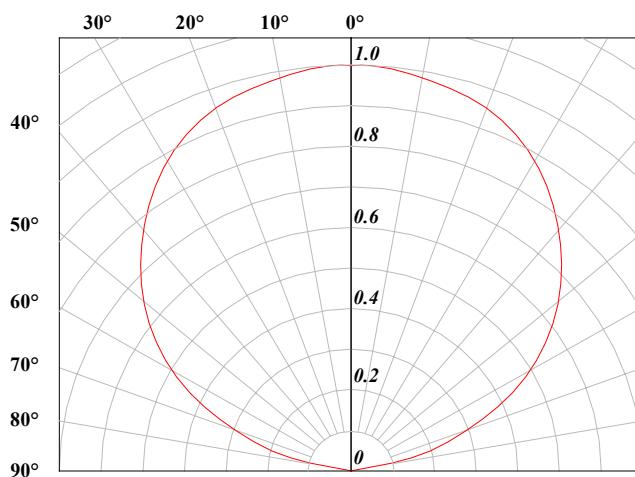

**Maximum current vs. temperature.**

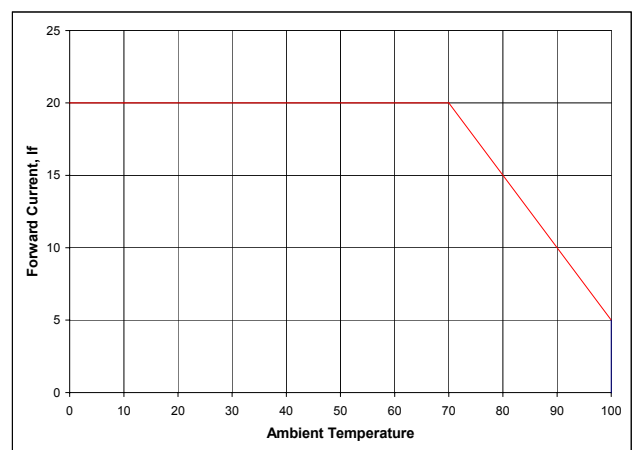

**Relative Intensity vs. Wavelength**

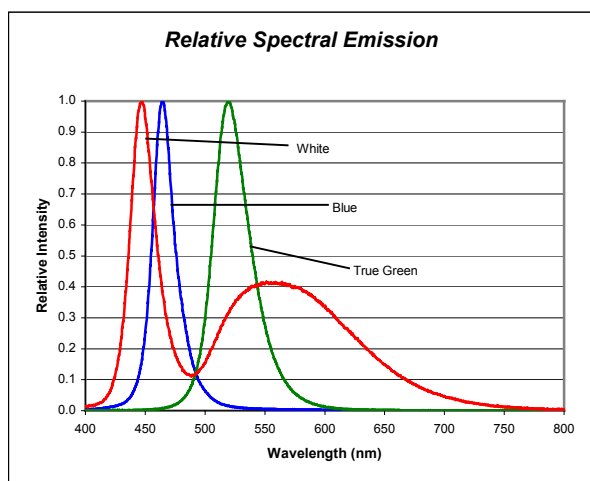

**Dominant Wavelength vs. Forward Current**

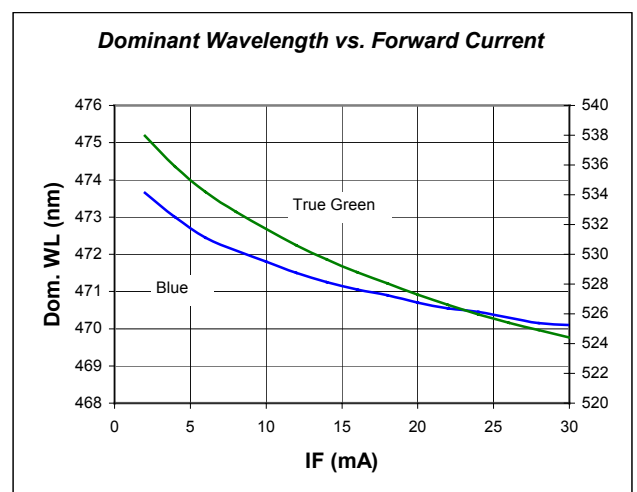



**Taping And Orientation.**

Reels come in quantity of 8000 units or 2000 units.

Reel diameters are 330 mm and 180 mm respectively.

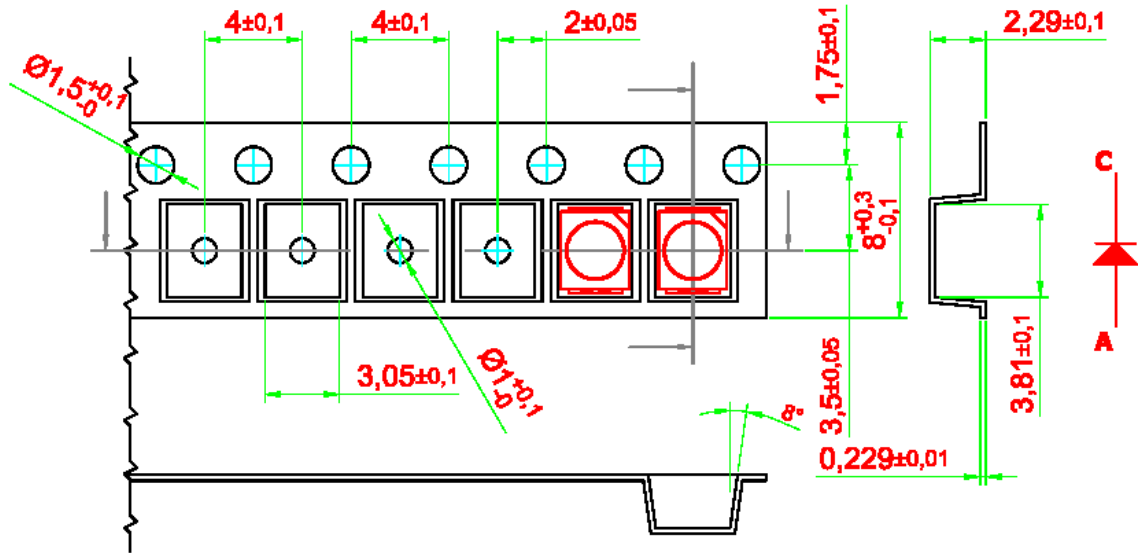

200 mm min. for Ø180 reel.  
200 mm min. for Ø330 reel.

480 mm min. for Ø180 reel.  
960 mm min. for Ø330 reel.

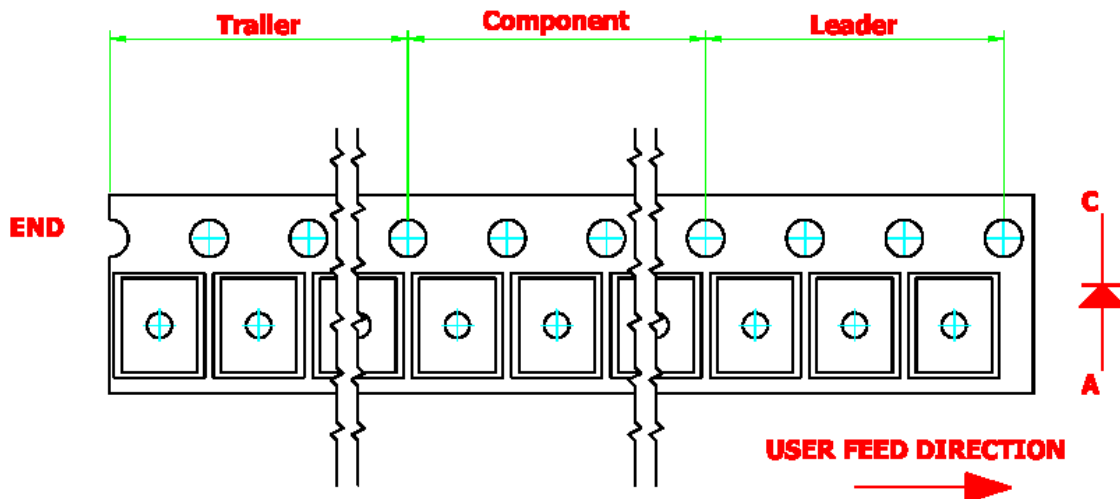



**Recommended Sn-Pb IR-Reflow Soldering Profile.**

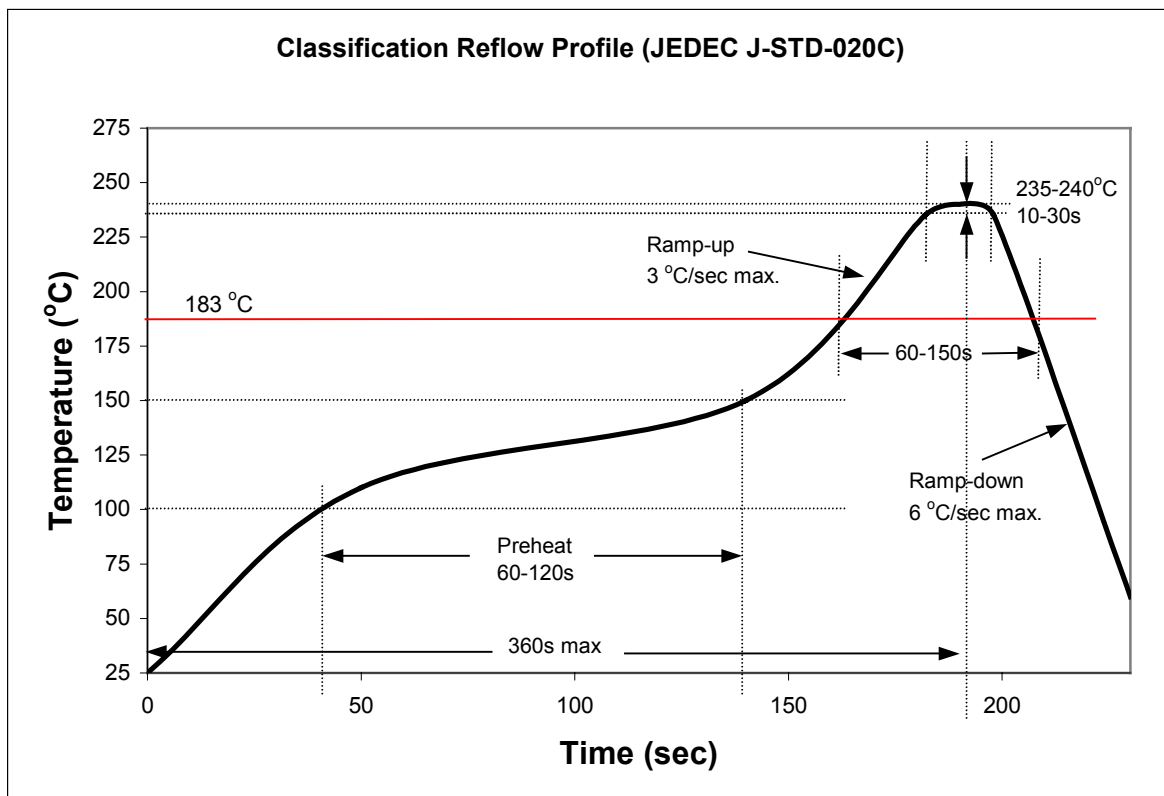

**Recommended Pb Free IR-Reflow Soldering Profile.**

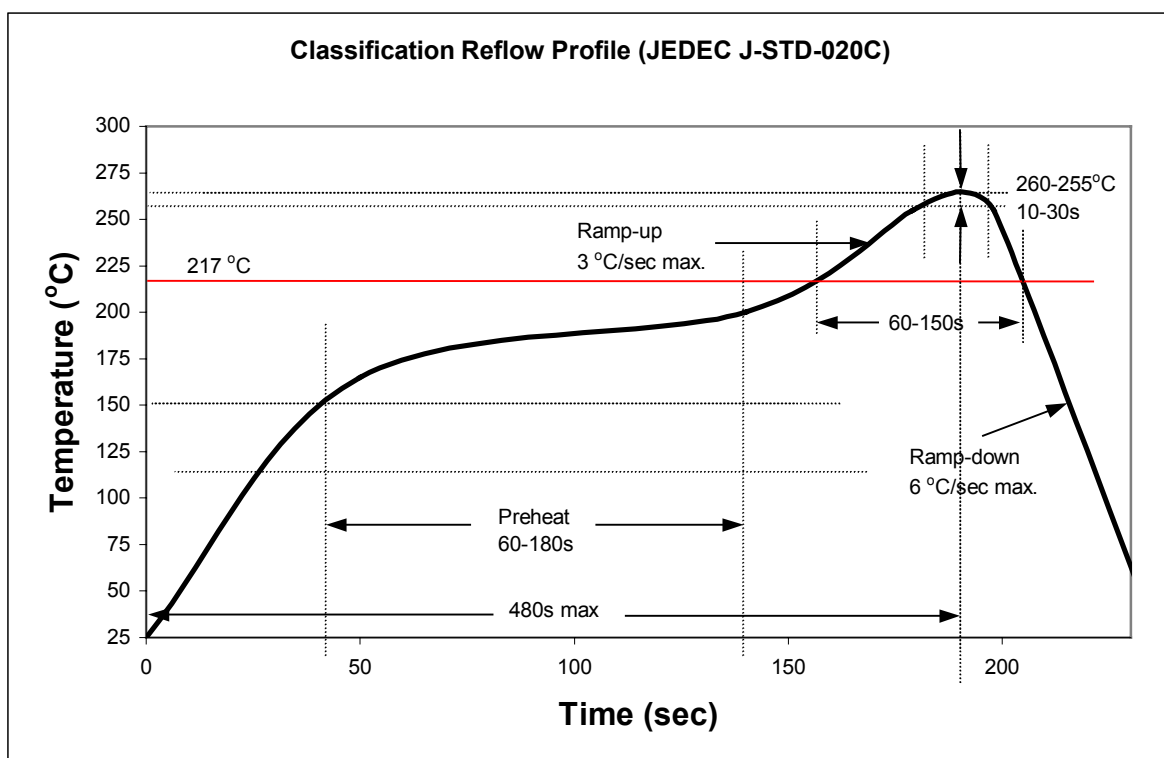



**Recommended TTW Soldering Profile.**

