

| ITEM | Q'TY | PART NUMBER | PART DESCRIPTION                             |
|------|------|-------------|--|
| 1    | 1    | LP-4H       | Shell, 4 High, Right Angle Light Pipe        |
| 2    | 1    | LP-4LP      | Light Pipe, 4 High, Right Angle, Low Profile |

| REV. | DESCRIPTION                    | DATE     | APPROVED |
|------|--------------------------------|----------|----------|
| B    | Engineering Update w/o Changes | 03/08/04 | M. C.    |
| C    | Added Note                     | 05/16/08 | M. C.    |
|      |                                |          |          |
|      |                                |          |          |

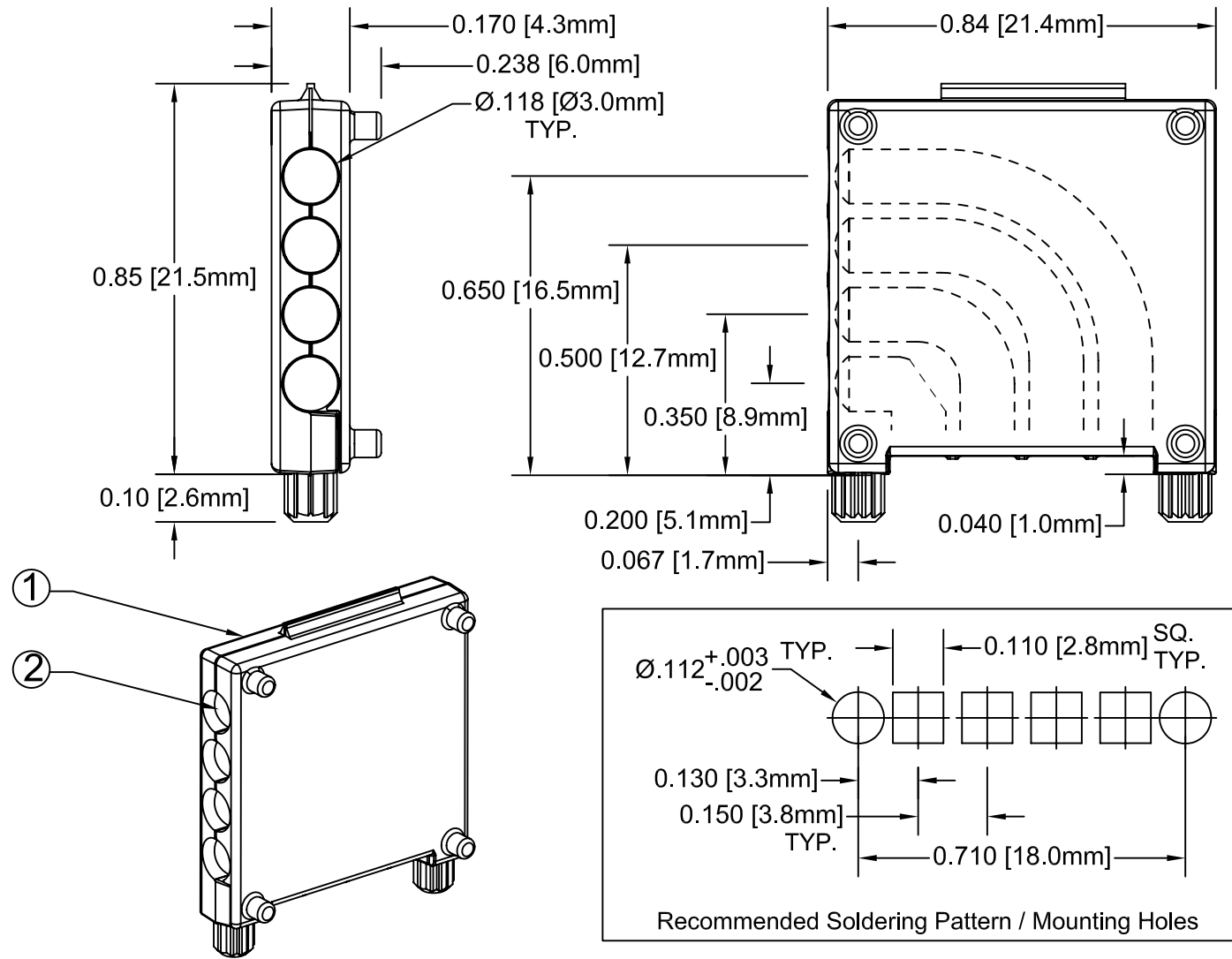

| STANDARD TOLERANCE<br>(UNLESS OTHERWISE SPECIFIED) |                          | BIVAR®  |                     |
|--|--------------------------|---|---------------------|
| DECIMALS   | ANGULAR                  | 4 THOMAS, IRVINE, CA. 92618   |                     |
| .X ± .1  | X° ± 1°                  | TEL: (949) 951-8808   | FAX: (949) 951-3974 |
| .XX ± .02  |                          | <b>TITLE:</b> QUAD-LEVEL LIGHT PIPE ASSEMBLY, RECESSED LENS<br><b>PART NO:</b> LP4-LP<br><b>REVISION:</b> C |                     |
| .XXX ± .010  |                          |   |                     |
| DESIGNED:<br><b>Michael Chen</b>                   | DATE:<br><b>08/26/02</b> | CAGE CODE : 32559 SHEET # 1 OF 1  |                     |
| CHECKED:<br><b>S. Irving</b>                       | DATE:<br><b>08/26/02</b> | CAD GENERATED DOCUMENT, DO NOT MEASURE DRAWING.   |                     |

Note: Pre-Assembled and Ultrasonically Welded