



Mosaic  
Semiconductor  
Inc.

**128K x 32 FLASH MODULE**

**PUMA 67F4000-15/20/25**

Issue 1.1 : May 1994

**ADVANCE PRODUCT INFORMATION**

4,194,304 bit CMOS FLASH Memory Module

**Features**

- Fast access times of 150/200/250 ns.
- User Configurable as 32 / 16 / 8 bit wide.
- Operating Power @ 1MHz 120 / 70 / 45 mW (typical).
- Low Power Standby 400  $\mu$ W (maximum).
- Single High Voltage for Erase/Write :  $V_{pp}=12.0V \pm 0.6$ .
- Byte Write Time of 25  $\mu$ s (typical).
- Automatic On-Chip Erase Function with Status Polling.
- Flash Electrical Erase of Module, 1 second (typical).
- $10^4$  Erase/Write Cycle Endurance minimum.
- On board decoupling capacitors.
- Module Components may be processed to MIL-STD-883, non-compliant.

**Block Diagram**

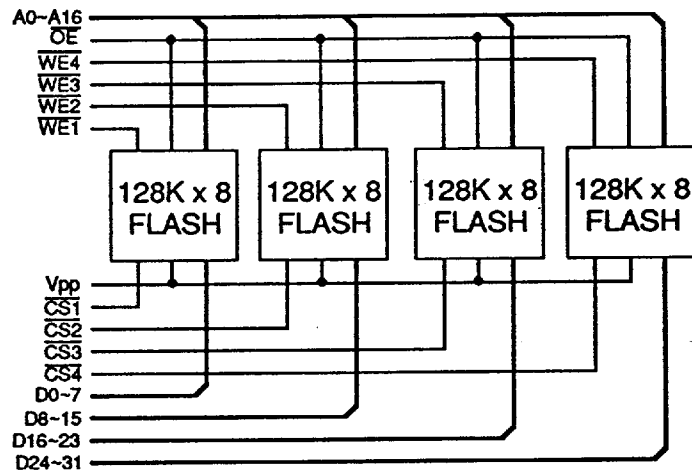

**Pin Definition**

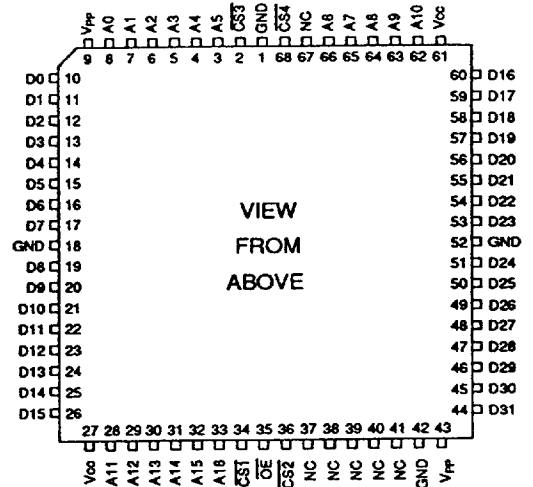

**Pin Functions**

- A0-A16** Address Inputs
- D0-D31** Data Input/Output
- CS1-4** Chip Selects
- OE** Output Enable
- WE1-4** Write Enables
- V<sub>pp</sub>** Write/Erase Input Voltage
- V<sub>cc</sub>** Power (+5V)
- GND** Ground

**Package Details** Dimensions in mm (inches).

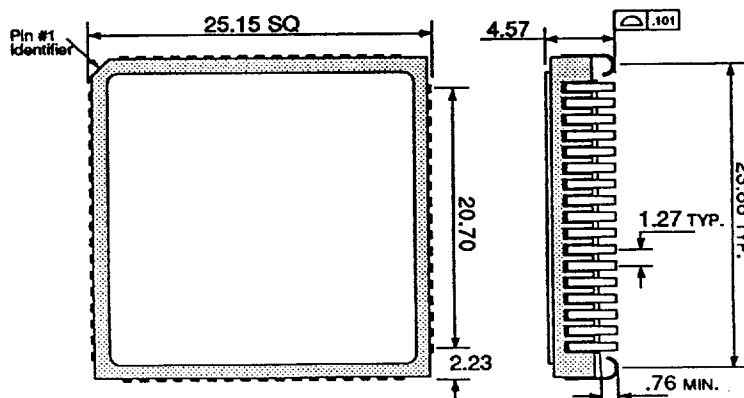

**GENERAL DESCRIPTION**

The PUMA 2F4000 is a 4,194,304 bit CMOS FLASH memory device. Using  $\overline{CS1-4}$ , its' outputs are configurable as 8, 16 or 32 bits wide, allowing flexibility in a wide range of applications.

FLASH memory combines the functionality of EPROM with on-board electrical Write/Erasure. The PUMA 2F4000 utilizes devices which use a Command Register to manage these functions, allowing fixed power supply during Write/Erase and maximum EPROM compatibility. During Write cycles, the command register internally latches address and data needed for the Write and Erase operations, thus simplifying the external control circuitry.

When normal TTL/CMOS logic levels are applied to the  $V_{PP}$  pin, the module displays normal EPROM Read, Standby and Output Disable. However, when high voltage ( $V_{PPH}$ ) is applied to  $V_{PP}$  the Write /Erase options are available as well as the Read.

FLASH technology reliably stores data even after 10,000 Write/Erase cycles and utilizes a single program supply of 12V±5%. Additionally, the interactive program algorithm allows a typical room temperature program time of less than 4 seconds for the entire module (in 32 bit mode). The typical module erasure time is less than 1 second.

**Absolute Maximum Ratings <sup>(1)</sup>**

Temperature Under Bias	$T_{OPR}$	-55 to +125 °C
Storage Temperature	$T_{STG}$	-65 to +150 °C
Voltage on Any Pin with respect to GND <sup>(2)</sup>	$V_{IN,OUT}$	-0.3 to + 6.5 V
Voltage on A9 pin with respect to GND <sup>(2)</sup>	$V_{ID}$	-0.3 to 13.5 V
Voltage on $V_{PP}$ pin with respect to GND	$V_{PP}$	-0.3 to +14.0 V
$V_{CC}$ Supply Voltage <sup>(2)</sup>	$V_{CC}$	-0.3 to +5.5 V

Notes :(1) Stresses above those listed may cause permanent damage to the device. These are stress ratings only, and functional operation of the device at these or any other conditions above those indicated in the operational sections of this specification is not implied. Exposure to absolute maximum rating conditions for extended periods may affect device reliability.

(2)  $V_{IN}$ ,  $V_{OUT}$ ,  $V_{ID}$  minimum = -2.0V for pulse width of less than 20 ns.

**Recommended Operating Conditions**

		<i>min</i>	<i>typ</i>	<i>max</i>	
Supply Voltage	$V_{CC}$	4.5	5.0	5.5	V
Programming Voltage	Read $V_{PPL}$	$V_{CC}-1.0$	-	$V_{CC}$	V
	Write/Erase/Verify $V_{PPH}$	11.4	12.0	12.6	V
Identifier Voltage	$V_{ID}$	11.4	12.0	12.6	V
Input High Voltage	TTL $V_{IH}$	2.2	-	$V_{CC}+1.0$	V
Input Low Voltage	TTL $V_{IL}$	-0.3	-	0.8	V
Operating Temperature	$T_A$	0	-	70	°C
	$T_{AI}$	-40	-	85	°C (-I suffix)
	$T_{AI}$	-55	-	125	°C (-M,-MB suffix)

**Capacitance ( $T_A=25^\circ\text{C}, f=1\text{MHz}$ )**

Parameter	Symbol	Test Condition	<i>typ</i>	<i>max</i>	Unit	
Input Capacitance	$\overline{CS1-4}, \overline{WE1-4}$	$C_{IN1}$	$V_{IN}=0V$	-	16	pF
	Other pins	$C_{IN2}$	$V_{IN}=0V$	-	34	pF
Output Capacitance	32 bit	$C_{OUT32}$	$V_{OUT}=0V$	-	22	pF

Note : These parameters are calculated, not measured.

**DC Electrical Characteristics** ( $T_A = -55^\circ\text{C}$  to  $+125^\circ\text{C}$ ,  $V_{CC} = 5V \pm 10\%$ )

Parameter	Symbol	Test Condition	min	typ <sup>(2)</sup>	max	Unit
I/P Leakage Current	Address, $\overline{OE}$	$I_{LI1}$	$V_{IN} = 0V$ to $V_{CC}$ , $V_{PP} = V_{PPL}$ or $V_{PPH}$	-	-	8 $\mu\text{A}$
	$\overline{WE1-4}$ , $\overline{CS1-4}$	$I_{LI2}$	As above	-	-	2 $\mu\text{A}$
Output Leakage Current	32 bit	$I_{LO}$	$V_{OUT} = 0V$ to $V_{CC}$ , $V_{PP} = V_{PPL}$ or $V_{PPH}$ , 8 bit	-	-	2 $\mu\text{A}$
$V_{PP}$ Current		$I_{PP1}$	$V_{PP} = 5.5V$	-	-	2 mA
		$I_{PP2}$	$V_{PP} = 12.6V$	-	-	4 mA
$V_{CC}$ Read Current	32 bit	$I_{CCR132}$	$\overline{CS} = V_{IL}^{(1)}$ , $\overline{OE} = V_{IH}^{(1)}$ , $I_{OUT} = 0\text{mA}$ , $f = 1\text{MHz}$	-	24	80 mA
	16 bit	$I_{CCR116}$	As above	-	14	46 mA
	8 bit	$I_{CCR18}$	As above	-	9	29 mA
	32 bit	$I_{CCR832}$	$\overline{CS} = V_{IL}^{(1)}$ , $\overline{OE} = V_{IH}^{(1)}$ , $I_{OUT} = 0\text{mA}$ , $f = 6.67\text{MHz}$	-	100	240 mA
	16 bit	$I_{CCR816}$	As above	-	52	126 mA
	8 bit	$I_{CCR88}$	As above	-	28	69 mA
$V_{CC}$ Write/Erase Current	32 bit	$I_{CCE32}$	$\overline{CS} = V_{IL}^{(1)}$ , $V_{PP} = V_{PPH}$ , Write/Erase in progress	-	20	80 mA
	16 bit	$I_{CCE16}$	As above	-	12	46 mA
	8 bit	$I_{CCE8}$	As above	-	8	29 mA
$V_{CC}$ Auto Erase Current	32 bit	$I_{CCA32}$	$\overline{CS} = V_{IL}^{(1)}$ , $V_{PP} = V_{PPH}$ , Auto Erase in progress	-	40	200 mA
	16 bit	$I_{CCA16}$	As above	-	22	106 mA
	8 bit	$I_{CCA8}$	As above	-	13	59 mA
$V_{PP}$ Write/Erase Current	32 bit	$I_{PPE32}$	$\overline{CS} = V_{IL}^{(1)}$ , $V_{PP} = V_{PPH}$ , Write/Erase in progress	-	40	160 mA
	16 bit	$I_{PPE16}$	As above	-	22	86 mA
	8 bit	$I_{PPE8}$	As above	-	13	49 mA
$V_{PP}$ Auto Erase Current	32 bit	$I_{PPA32}$	$\overline{CS} = V_{IL}^{(1)}$ , $V_{PP} = V_{PPH}$ , Auto Erase in progress	-	140	400 mA
	16 bit	$I_{PPA16}$	As above	-	72	206 mA
	8 bit	$I_{PPA8}$	As above	-	38	109 mA
Standby Supply Current	TTL	$I_{SB1}$	$V_{CC} = V_{CC} \text{ max}$ , $\overline{CS} = V_{IH}^{(1)}$	-	-	3 mA
	CMOS	$I_{SB2}$	$V_{CC} = V_{CC} \text{ max}$ , $\overline{CS} = V_{CC}^{(1)}$	-	-	500 $\mu\text{A}$
Output Low Voltage		$V_{OL}$	$I_{OL} = 2.1\text{mA}$	-	-	0.45 V
Output High Voltage	TTL loading	$V_{OH}$	$I_{OH} = -400\mu\text{A}$	2.4	-	V

- Notes (1)  $\overline{CS}$  above are accessed through  $\overline{CS1-4}$ . These inputs must be operated simultaneously for 32 bit operation, in pairs in 16 bit mode and singly for 8 bit mode.  
 (2) Typical figures are measured at  $25^\circ\text{C}$  and nominal  $V_{CC}$   
 (3) Maximum active current is the sum of  $I_{CC}$  and  $I_{PP}$ .  
 (4) **CAUTION:** the PUMA 67F4000 must not be removed from or inserted into a socket when  $V_{CC}$  or  $V_{PP}$  is applied.

**AC Test Conditions**

- \* Input pulse levels: 0.45V to 2.4V.
- \* Input rise and fall times:  $\leq 10\text{ns}$ .
- \* Input and Output timing reference levels: 1.5V
- \* Output load : see diagram.
- \* Module is tested in 32 bit mode.

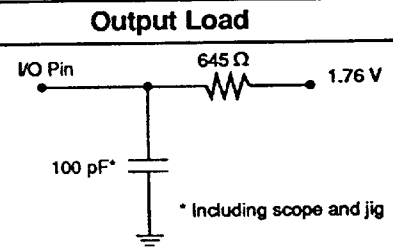

**AC Read Characteristics**

Parameter	Symbol	-15		-20		-25		Unit
		min	max	min	max	min	max	
Chip Select Access Time	$t_{CS}$	-	150	-	200	-	250	ns
Address Access Time	$t_{ACC}$	-	150	-	200	-	250	ns
Output Enable Access Time	$t_{OE}$	-	70	-	80	-	90	ns
Output Disable to Output in High Z <sup>(1)</sup>	$t_{DF}$	0	50	0	60	0	70	ns
Output Hold Time	$t_{OH}$	5	-	5	-	5	-	ns

Notes: (1)  $t_{DF}$  is defined as the time at which the outputs achieve the open circuit conditions and are not referenced to output voltage levels. This parameter is not 100% tested.

**Read Cycle Timing Waveform**

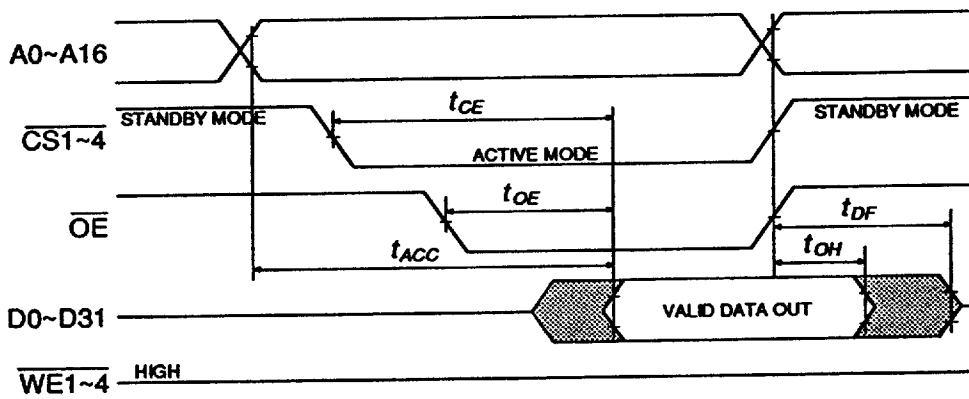

**AC Write/Erase/Program Characteristics ( $V_{CC} = 5V \pm 10\%$ )**

Parameter	Symbol	-15		-20		-25		Unit
		min	max	min	max	min	max	
Command Programming Cycle Time	$t_{CWC}$	150	-	200	-	250	-	ns
Address Setup Time	$t_{AS}$	0	-	0	-	0	-	ns
Address Hold Time	$t_{AH}$	60	-	60	-	60	-	ns
Data Setup Time	$t_{DS}$	50	-	50	-	50	-	ns
Data Hold Time	$t_{DH}$	10	-	10	-	10	-	ns
Chip Select Setup Time	$t_{CES}$	0	-	0	-	0	-	ns
Chip Select Hold Time	$t_{CEH}$	0	-	0	-	0	-	ns
$V_{PP}$ Setup Time	$t_{VPS}$	100	-	100	-	100	-	ns
$V_{PP}$ Hold Time	$t_{VPH}$	100	-	100	-	100	-	ns
Write Programming Pulse Width	$t_{WEP}$	90	-	90	-	90	-	ns
Write Programming Pulse Width High	$t_{WEH}$	20	-	20	-	20	-	ns
Output Enable Setup Before Command	$t_{OEWS}$	0	-	0	-	0	-	ns
Output Enable Setup before Verify	$t_{OERS}$	6	-	6	-	6	-	$\mu$ s
Verify Access Time	$t_{VA}$	-	150	-	200	-	250	ns
Output Enable Setup before Status Polling	$t_{OEPS}$	20	-	20	-	20	-	ns
Status Polling Access Time	$t_{SPA}$	-	150	-	200	-	250	ns
Standby Time before Programming	$t_{PPW}$	25	-	25	-	25	-	$\mu$ s
Standby Time in Erase	$t_{ET}$	9	11	9	11	9	11	ms
Output Disable Time <sup>(3)</sup>	$t_{DF}$	0	50	0	60	0	70	ns
Automatic Erase Time	$t_{AET}$	0.5	30	0.5	30	0.5	30	s

- Notes (1)  $\overline{CS1-4}$ ,  $\overline{OE}$  and  $\overline{WE1-4}$  must be fixed High during  $V_{PP}$  transition from  $V_{PPL}$  to  $V_{PPH}$  or from  $V_{PPH}$  to  $V_{PPL}$ .  
 (2) Refer to Read Operation when  $V_{PP} = V_{PPL}$ .  
 (3)  $t_{DF}$  is defined as the time at which the outputs achieve the open circuit conditions and are not referenced to output voltage levels. This parameter is not 100% tested.

**Programming Timing Waveform**

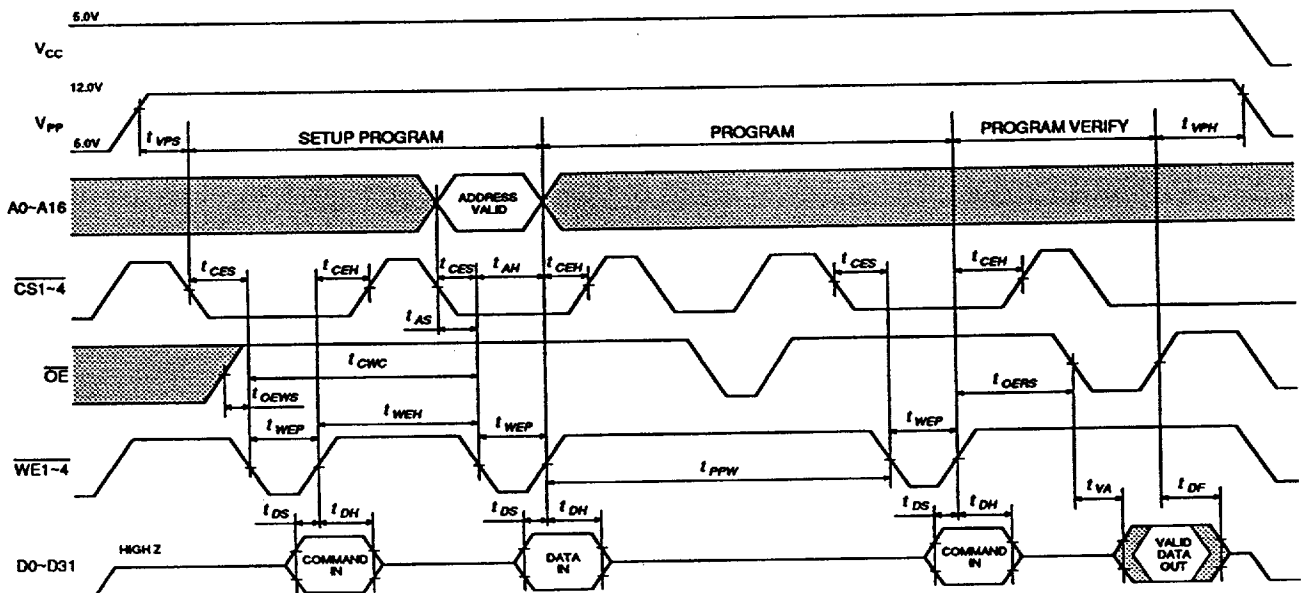

Erase Timing Waveform

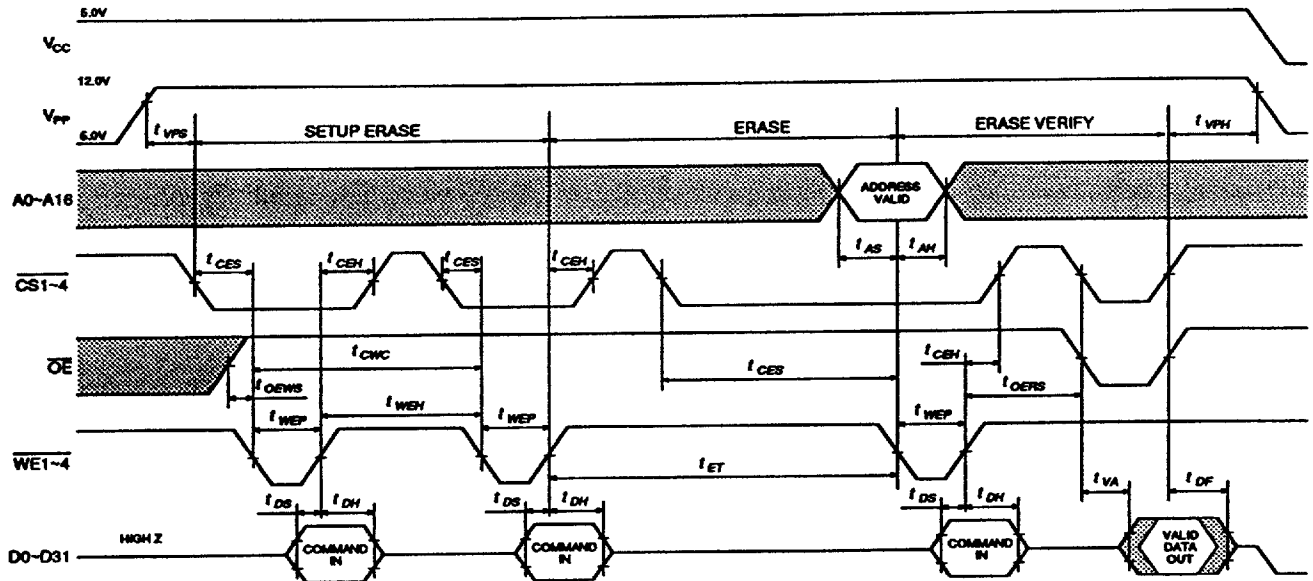

Automatic Erase Timing Waveform

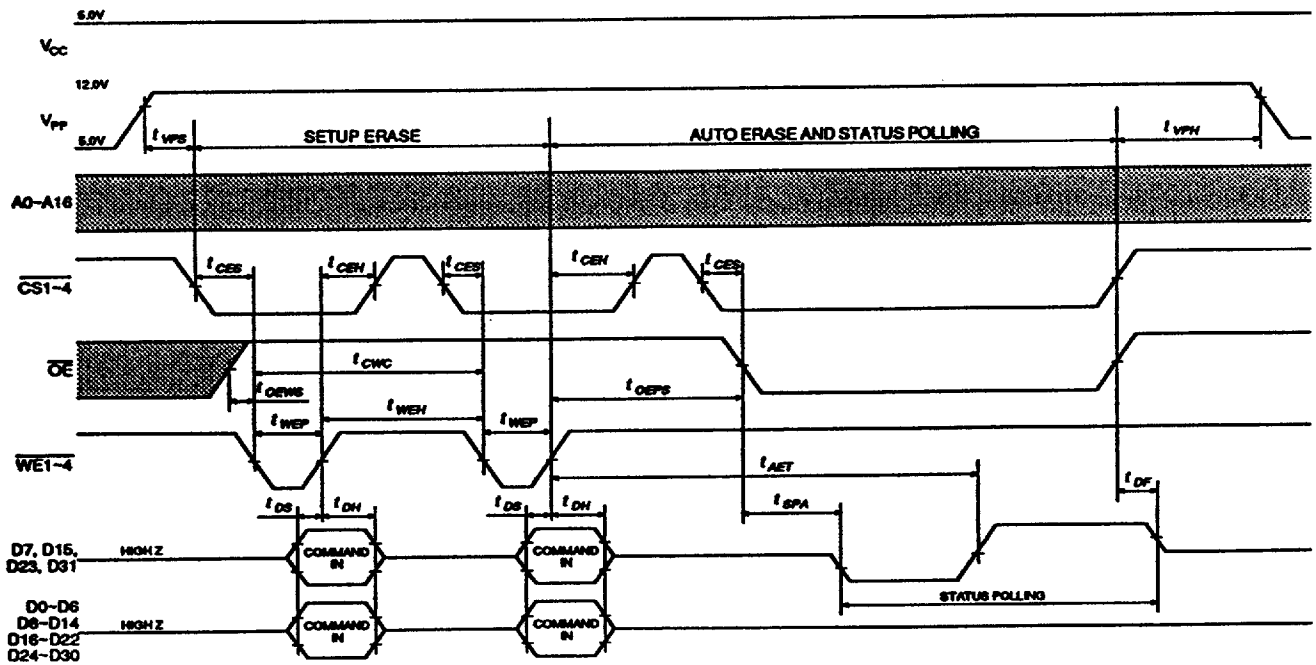

## BUS OPERATIONS

**Read** Two control functions are provided, both of which must be logically active to obtain data at the outputs. Chip Select selects the module and controls the power, while Output Enable gates data from the output pins - see the Read Cycle Timing Waveform for details.

**Write** Module Write/Erase are accessed via the command register while  $V_{PP}$  is at  $V_{PPH}$ . Note that the register itself does not occupy an addressable memory location, but is simply a latch used to store the command and address/data information required to execute the command.

With Chip Select and Write Enable at  $V_{IL}$  the command registers are accessed; addresses are latched on the falling edge of Write Enable and data latched on the rising edge of Write Enable. The three most significant bits of each register (D7- D5) encode the command

function while the other bits (D4-D0) must be zero. The exception to this is the Reset command when data  $FF_H$  is written to the registers and Identifier mode when  $90_H$  is written to the registers.

**Output Disable** When Output Enable is at  $V_{IH}$  the output pins are placed in a high impedance state and output from the module is disabled.

**Standby** If Chip Select is held at  $V_{IH}$  the power consumption of the PUMA 2F4000 is substantially reduced because most of the on-board circuitry is disabled. The outputs are placed in a high impedance state (independent of Output Enable).

If the PUMA 2F4000 module is deselected and placed in Standby mode during Write/Erase and Verify cycles, the module will continue to draw normal active current until the operation is terminated.

PUMA 2F4000 Operating Modes

OPERATION		$V_{pp}$	A0	A9	$\overline{CS}$	$\overline{OE}$	$\overline{WE}$	D0 - D7
READ ONLY	Read	$V_{PPL}$	A0	A9	$V_{IL}$	$V_{IL}$	$V_{IH}$	Data out
	Output Disable	$V_{PPL}$	X	X	$V_{IL}$	$V_{IH}$	$V_{IH}$	Tri-State
	Standby	$V_{PPL}$	X	X	$V_{IH}$	X	X	Tri-State
	Manufacturer Identifier <sup>(1)</sup>	$V_{PPL}$	$V_{IL}$	$V_{ID}^{(2)}$	$V_{IL}$	$V_{IL}$	$V_{IH}$	Data = 07H
	Device Identifier <sup>(1)</sup>	$V_{PPL}$	$V_{IH}$	$V_{ID}^{(2)}$	$V_{IL}$	$V_{IL}$	$V_{IH}$	Data = 19H
READ/WRITE	Read <sup>(3)</sup>	$V_{PPH}$	A0	A9	$V_{IL}$	$V_{IL}$	$V_{IH}$	Data Out <sup>(5)</sup>
	Output Disable	$V_{PPH}$	X	X	$V_{IL}$	$V_{IH}$	$V_{IH}$	Tri-State
	Standby	$V_{PPH}$	X	X	$V_{IH}$	X	X	Tri-State
	Write	$V_{PPH}$	A0	A9	$V_{IL}$	$V_{IH}$	$V_{IL}$	Data In <sup>(4)</sup>

Notes (1) Device Identifier codes can be output in command programming mode. Refer to the Command Definition Table.

(2)  $11.4V \leq V_{ID} \leq 12.6V$

(3) Read operations with  $V_{PP} = V_{PPH}$  may access array data or identifier codes.

(4) Refer to Command Definition table for valid Data In during a Write operation. Data is Programmed, Erased or Verified after mode setting by command inputs.

(5) Status of AutoErase can be verified in this mode. Status output appears on D7, with D0-D6 in the high impedance state.

(6) X can be  $V_{IL}$  or  $V_{IH}$

(7) If  $V_{PP}$  is lowered from 12V to 5V in Erase or Program operation, the erasure or programming will stop.

(8)  $V_{CC}$  must be applied before  $V_{PP}$  and removed after  $V_{PP}$  is removed.

## COMMAND DEFINITIONS

With the  $V_{PP}$  pin at a low voltage the Command Register contents default to  $00_H$ , enabling Read-only operations. A high voltage on  $V_{PP}$  enables Read/Write modes with device operation selected by writing data into the Register - see the Command Definition table for details.

**Read** While  $V_{PP}$  is high the memory contents can be Read by first writing  $00_H$  into the Command Register and thereafter obeying the timings shown on the Read Cycle Waveform. This mode remains enabled until the Command Register contents are altered.

On power up the Register contents will be  $00_H$ , ensuring that the memory contents are not changed during the  $V_{PP}/V_{CC}$  power transition. When reading the PUMA67F4000,  $V_{PP}$  must be set within  $V_{SS}$  to  $V_{CC}$  (except during a Command Read).

**Intelligent Identifier** In order to use the correct programming and erase algorithms on PROM devices, these parts usually have built in codes to identify manufacturer and specific device. However, to access these codes address line A9 normally has to be placed at a high voltage, which is not considered good practice and leads to complications in PCB design.

The PUMA 2F4000 allows the identifiers to be accessed through the Command Register without placing a high voltage on A9. Writing  $90_H$  into the Registers starts this process with a subsequent Read from  $00000_H$  retrieving the manufacturer codes of  $07_H$  and a Read from  $00001_H$  giving the device codes  $19_H$ . To terminate this sequence another valid command must be written to the Register.

PUMA 2F4000 Command Definitions

COMMAND	Bus Cycles Req'd	First Bus Cycle			Second Bus Cycle		
		Operation <sup>(1)</sup>	Addr <sup>(2)</sup>	Data <sup>(3)</sup>	Operation <sup>(1)</sup>	Addr <sup>(2)</sup>	Data <sup>(3)</sup>
Read Memory <sup>(4)</sup>	1	Write	X	$00_H$	Read	RA	RD
Read Identifier Codes	2	Write	X	$90_H$	Read	IA	ID
Set-up Erase/Erase <sup>(5)</sup>	2	Write	X	$20_H$	Write	X	$20_H$
Erase Verify <sup>(5)</sup>	2	Write	EA	$A0_H$	Read	X	EVD
Set-up AutoErase/AutoErase <sup>(6)</sup>	2	Write	X	$30_H$	Write	X	$30_H$
Set-up Program/Program <sup>(7)</sup>	2	Write	X	$40_H$	Write	PA	PD
Program Verify <sup>(7)</sup>	2	Write	X	$C0_H$	Read	X	PVD
Reset	2	Write	X	$FF_H$	Write	X	$FF_H$

Notes (1) See Operating Modes Table.

- (2) IA = Identifier address.  $00000_H$  for Manufacturers code and  $00001_H$  for device code.  
 EA = Address of memory location to be read during Erase Verify.  
 PA = Address of memory location to be programmed.  
 RA = Address of memory location to be Read.

Addresses are latched on the falling edge of Write Enable pulse.

- (3) ID = Data read from location IA during device identification. (Manufacturer =  $07_H$ , Device =  $19_H$ )  
 EVD = Data read from location EA during Erase Verify.  
 PD = Data to be programmed at location PA. Data is latched on the rising edge of Write Enable.  
 RD = Data to be read from location RA during Read operation.  
 PVD = Data to be read from location PA during Program Verify. PA is latched on the Program command.
- (4) Command latch default value when applying 12.0V to  $V_{PP}$  is  $00_H$ , Device is in Read mode after  $V_{PP}$  is set to 12.0V.
- (5) All data in the chip is erased. Erasure occurs according to the fast High Reliability Erase Flowchart
- (6) All data in the chip is erased. The data is erased automatically by the internal logic circuitry, with external verification of the erase not required. Termination of erasure is verified by Status Polling after AutoErase begins.
- (7) Data is programmed according to the Fast High Reliability Programming Flowchart. The completion of programming after the program pulse must be verified by Status Polling once programming has begun.



**Set-up Program/Program** Set-up program is a command only operation which prepares the memories for byte programming, initiated by writing  $40_{\text{H}}$  into the command register.

Once Set-up program has been performed, the next Write Enable pulse causes data to be latched on the rising edge and the address is latched on the falling edge of this pulse. Internal programming begins on the rising edge and is terminated with the next rising edge of Write Enable used to write the program-verify command.

**Program-Verify** This module is programmed byte by byte, which can occur sequentially or at random, but the byte just written must be verified.

Writing  $C0_{\text{H}}$  to the command registers begins this operation, which also terminates the programming operation. The last byte written will be verified; no new address information is required as the previous address is latched. A Read Cycle can now be performed in order to compare the data just written with the byte contents. This process is shown by the Programming Algorithm.

**Set-up Erase/Erase** Set-up erase is a command only operation which prepares the memory for electrical erasure of all contents, initiated by writing  $20_{\text{H}}$  to the Command Registers.

In order to start erasure  $20_{\text{H}}$  must again be written to the registers; this two-step sequence ensures that accidental erasure will not occur. Additionally, if the  $V_{\text{PP}}$  pin is not at a high voltage the memory contents are protected against erasure.

**Erase-Verify** The Erase command erases all the contents of the memory, but after this operation all bytes must be verified. This is accomplished by writing  $A0_{\text{H}}$  to the Command Registers, with the address of the byte to be verified supplied as it is latched on the falling edge of the Write-Enable pulse. Reading  $FF_{\text{H}}$  from the addressed bytes indicates that they are erased. This command must be issued prior to each byte verification to latch its address.

If the data read is not  $FF_{\text{H}}$  another erase operation must be performed. Verification can then continue from the address of the last verified byte, and once all bytes have been verified the erase procedure is complete. This process is shown by the Erase algorithm.

The verify operation is halted by writing another valid command e.g. Set-up Program, into the command register.

**Automatic Erase** The Erase and Erase Verify processes can be performed automatically by writing  $30_{\text{H}}$  into the Command register, followed by a second write of  $30_{\text{H}}$  to initiate the AutoErase. Once initiated all of the locations in the PUMA 2F4000 will be set to  $FF_{\text{H}}$

automatically, without the need to verify each byte. Typically the whole device will be erased in 1 second, with the end of erasure being indicated by Status Polling.

**Status Polling** Status Polling allows the status of the FLASH memory to be determined. If the PUMA 2F4000 is set to the Status Polling mode during the Erase Cycle, D7 is lowered to  $V_{\text{OL}}$  to indicate that the PUMA 2F4000 is performing an Erase operation. When the Erase has terminated, D7 is set to  $V_{\text{OH}}$ . During Status Polling only D7 outputs data. D0 to D6 are in high impedance state (High Z). The Status Polling feature is only active during the automatic erase algorithm.

**Reset** This command, which consists of two consecutive writes of  $FF_{\text{H}}$ , will safely abort either Erase or Program operations after the Set-up commands. Memory contents will not be altered, and a valid command must then be written to place the device in the desired state.

---

## ALGORITHM NOTES

---

These algorithms **MUST BE FOLLOWED** to ensure correct and reliable device operation.

**Fast Pulse Programming Algorithm** This programming algorithm uses pulses of  $25\mu\text{s}$  duration in order to improve programming time. Each operation is followed by byte verification in order to check when the specified byte has been successfully programmed. The algorithm allows up to 20 such pulses per byte, even though most bytes will verify on the first or second pulse. Both the Write and Verify sequences take place with  $V_{\text{PP}} = V_{\text{PPH}}$ . See the Programming Algorithm for a full description.

**Fast Erase Algorithm** The Fast Erase algorithm uses a closed loop flow similar to that of the Programming Algorithm to reliably and quickly erase all memory contents.

Uniform and reliable erasure is guaranteed by first writing  $00_{\text{H}}$  to all memory locations. This can be accomplished using the Fast Pulse Programming algorithm. Erase execution then proceeds with an initial Erase operation, after which Erase Verification (data =  $FF_{\text{H}}$ ) begins at address  $00_{\text{H}}$ . This continues through the devices until the last address is reached or any data other than  $FF_{\text{H}}$  is found. With each subsequent Erase operation a greater number of bytes will verify to the erased state.

The erase time may be minimized by storing the address of the last byte verified; after the next Erase operation verification can begin at this address, circumventing the need to re-verify previously erased locations. Erasure occurs typically in 1 second.

---

**Timing Delays** Four timing delays are associated with the Program and Erase algorithms described:

- (1) When  $V_{pp}$  first turns on the capacitors on the  $V_{pp}$  line cause an RC ramp, the rise time of which is proportional to the number of devices being erased and the capacitance per device.  $V_{pp}$  must reach its final value 100ns before any commands are executed.
- (2) The second timing delay is the erase time pulse width of 10ms, which should be timed by a micro-processor routine. This operation is terminated by writing the Erase/Verify Command; if this command is not issued the memory cell will be driven into depletion (no internal times).
- (3) Each programming operation lasts 25 $\mu$ s, and since the algorithm is interactive each byte is verified after a Write pulse; the program operation must be terminated at the conclusion of the timing routine.
- (4) In order to improve memory cell operation, an internally generated margin voltage is applied to the addressed cell during Write/Erase Verify. It is during this 6 $\mu$ s delay that the internal circuitry is changing voltage levels between the Erase/Write level and those used for Verify and Read operations. Any attempt to Read the device(s) during this period will result in possible false data appearing on the outputs.

---

## DESIGN CONSIDERATIONS

---

**Two Line Control** Two Read signals are provided for output control to accommodate large memory arrays, giving the lowest possible memory power dissipation and ensuring bus contention does not occur.

**Supply Decoupling** Flash memory power-switching characteristics require careful decoupling. Three supply current issues have to be considered - Standby, Active and transient current peaks caused by rising and falling edges of Chip Select.

Two line control and correct decoupling capacitor selection will help to suppress these transient voltage peaks. Each PUMA 2F4000 device should have a 0.1 $\mu$ F ceramic capacitor between  $V_{cc}$  and GND and between  $V_{pp}$  and GND. These high frequency, low inductance capacitors should be placed as close as possible to the PUMA 2F4000.

Additionally, it is recommended that a 4.7 $\mu$ F electrolytic capacitor should be placed between  $V_{cc}$  and GND every eight PUMA 2F4000 devices. This capacitor will smooth out voltage dips in the supply caused by PCB track inductance and will supply charge to the on-board capacitors as needed.

**$V_{pp}$  Trace** Because Flash memories are designed to be programmed in situ, the PCB designer must be made aware of the  $V_{pp}$  supply trace. This should be made similar to the  $V_{cc}$  bus as the  $V_{pp}$  pin supplies the memory cell current for Programming and Erase.

**Power Up/Down** When lowering  $V_{pp}$  to  $V_{cc}$  or less,  $V_{cc}$  must be set to 5V.  $V_{cc}$  must be applied before  $V_{pp}$  and removed after  $V_{pp}$  is removed.

**PROGRAMMING ALGORITHM**

These algorithms **MUST BE FOLLOWED** to ensure proper and reliable operation, and are shown for a single device only.

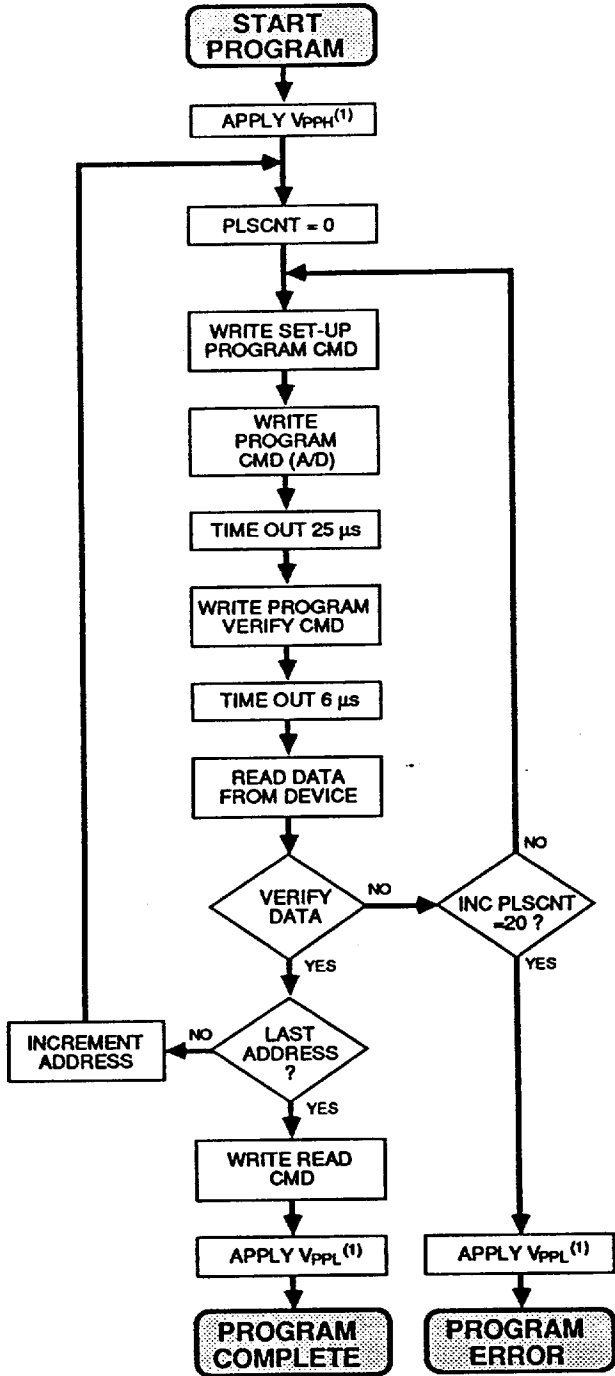

**Notes**

(1) See DC Characteristics for the value of  $V_{ppH}$ . When  $V_{pp}$  is switched,  $V_{pPL}$  may be GND, NC with a resistor tied to GND or less than  $V_{cc} + 2.0V$

**ERASE ALGORITHM**

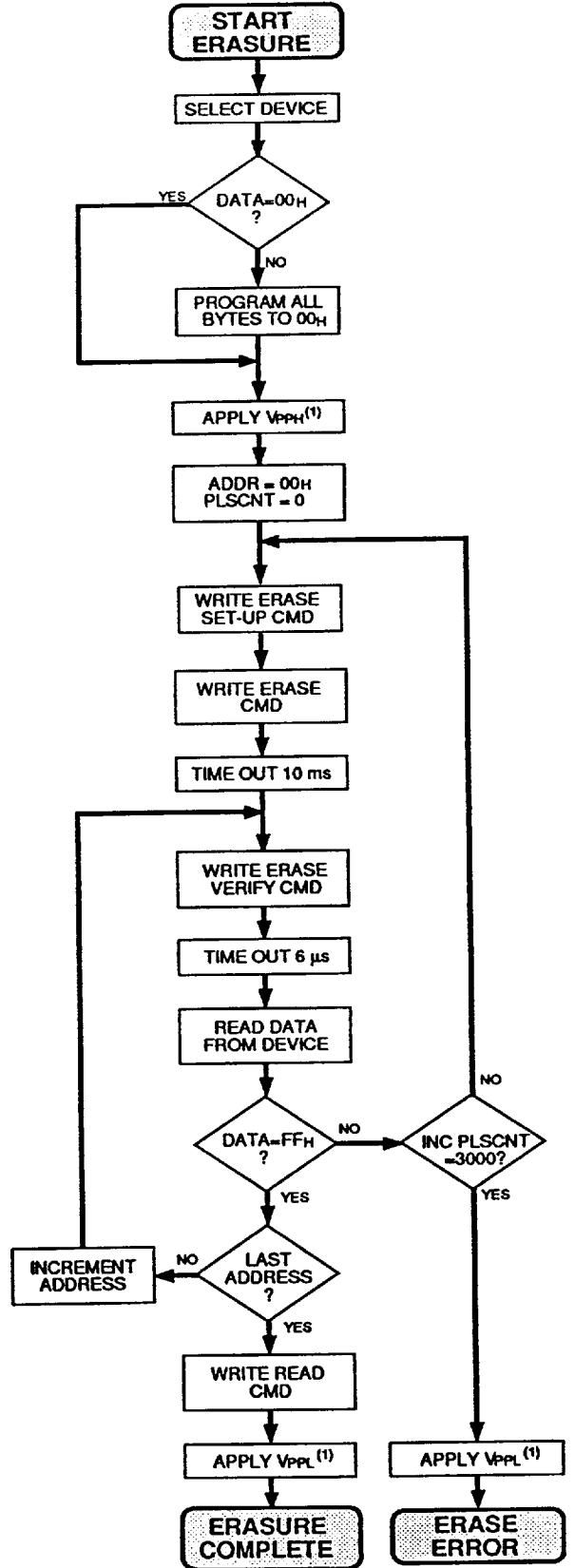

**Ordering Information**

**PUMA 67F4000MB-15**

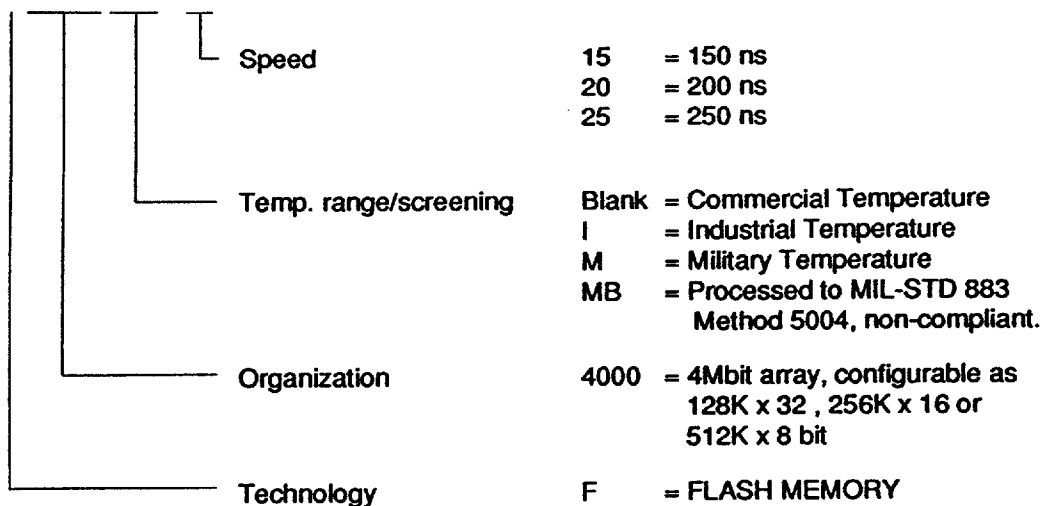

The policy of the company is one of continuous development and while the information presented in this data sheet is believed to be accurate, no liability is assumed for any data contained within. The company reserves the right to make changes without notice at any time.

© 1988 This design is the property of Mosaic Semiconductor, Inc.

*mosaic*

Mosaic  
Semiconductor  
Inc.

7420 Carroll Road  
San Diego, CA 92121  
Tel: (619) 271 4565  
FAX: (619) 271 6058

■ 6353379 0002320 163 ■ MOC