

# Panasonic®

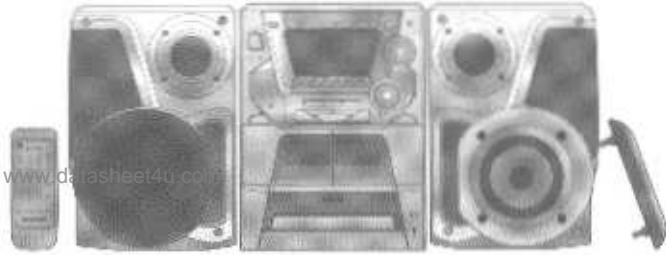

The illustrations show SC-AK44.

## CD Stereo System

### Operating Instructions

Model No. **SC-AK44**  
**SC-AK33**  
**SC-AK22**

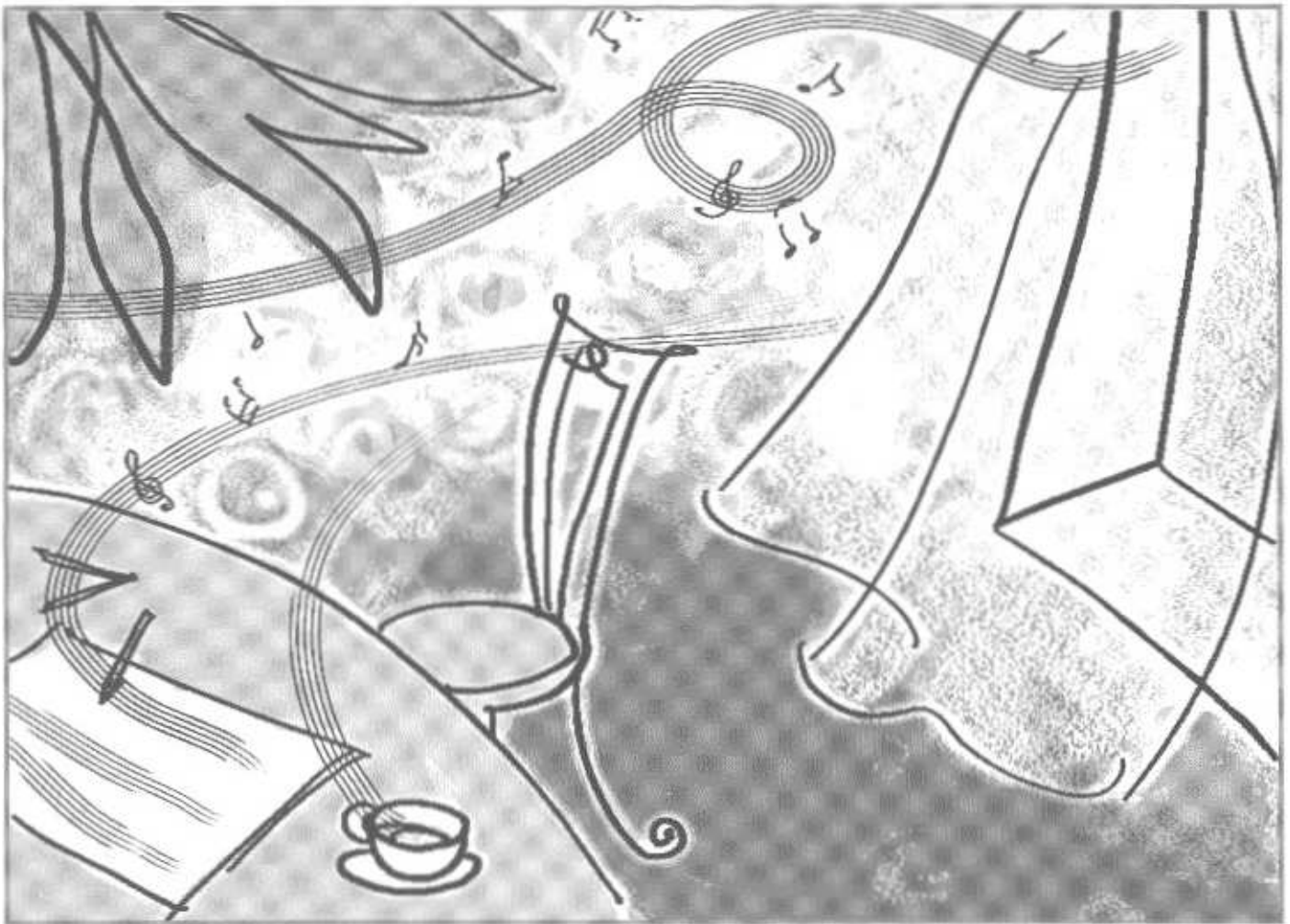

COMPACT  
**disc**  
DIGITAL AUDIO

Before connecting, operating or adjusting this product, please read these instructions completely.  
Please keep this manual for future reference.

P | PC

RQT5621-1P

[www.DataSheet4U.com](http://www.DataSheet4U.com)

## Dear customer

Thank you for purchasing this product.  
For optimum performance and safety, please read these instructions carefully.

These operating instructions are applicable to the following system.  
These operating instructions, however, fundamentally explain the operation of system SC-AK44.

System	SC-AK44	SC-AK33	SC-AK22
Main unit	SA-AK44	SA-AK33	SA-AK22
Speakers	SB-AK44	SB-AK33	SB-AK22

The model number and serial number of this product can be found on either the back or the bottom of the unit.  
Please note them in the space provided below and keep for future reference.

MODEL NUMBER \_\_\_\_\_

SERIAL NUMBER \_\_\_\_\_

### User memo:

DATE OF PURCHASE \_\_\_\_\_

DEALER NAME \_\_\_\_\_

DEALER ADDRESS \_\_\_\_\_

TELEPHONE NUMBER \_\_\_\_\_

### CAUTION!

**THIS PRODUCT UTILIZES A LASER.  
USE OF CONTROLS OR ADJUSTMENTS OR PERFORMANCE OF PROCEDURES OTHER THAN THOSE SPECIFIED HEREIN MAY RESULT IN HAZARDOUS RADIATION EXPOSURE. DO NOT OPEN COVERS AND DO NOT REPAIR YOURSELF. REFER SERVICING TO QUALIFIED PERSONNEL.**

### WARNING:

**TO REDUCE THE RISK OF FIRE, ELECTRIC SHOCK OR PRODUCT DAMAGE, DO NOT EXPOSE THIS APPLIANCE TO RAIN, SPLASHING, DRIPPING OR MOISTURE.**

### CAUTION:

**TO PREVENT ELECTRIC SHOCK MATCH WIDE BLADE OF PLUG TO WIDE SLOT, FULLY INSERT.**

## Table of contents

### Before using

Supplied accessories .....	2
PRECAUTIONS .....	4
Placement of speakers .....	5
Concerning the remote control .....	5
Battery installation .....	5
Correct method of use .....	5
Connections .....	6
Basic connections (for supplied accessories) .....	6
Optional antenna connections .....	7
External unit connection .....	7
Front panel controls .....	8
Turning the demo function off .....	10
Auto-off function .....	10
Setting the time .....	11
Convenient functions .....	11

### Radio operations

Listening to radio broadcasts .....	12
Presetting radio broadcasts .....	13

### Compact disc operations

Concerning compact discs .....	14
Listening to compact discs .....	15
Direct access play .....	16
Repeat play .....	16
Random play .....	16
Program play .....	17
To listen to special CDs and tracks (CD Manager function) .....	18

### Cassette deck operations

Listening to tapes .....	19
--------------------------	----

## Supplied accessories

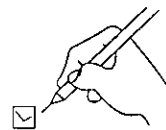

Please check and identify the supplied accessories.

Use numbers indicated in parentheses when asking for replacement parts.

(Only for U.S.A.)

To order accessories contact 1-800-332-5368 or web site (<http://www.panasonic.com>).

- AC power supply cord ..... 1 pc.  
(RJA0065-A)

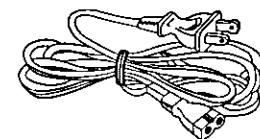

- FM indoor antenna (RSA0006-J) ..... 1 pc.



## Recording operations

Before recording (Deck 2 only) .....	20
Tape-to-tape recording .....	21
Recording from radio broadcasts .....	22
Recording from compact discs .....	23
To record special CDs and tracks (CD Manager function) .....	24

## Sound quality/sound field operations

Using the built-in sound quality/ sound field settings .....	25
Enhancing the sound quality .....	25
Boosting the super woofer .....	25
Varying the sound quality with the manual equalizer .....	26
Varying the sound quality with the acoustic image (AI) equalizer .....	26

## Timer operations

Using the timer .....	27
Using the play/record timer .....	27
Using the sleep timer .....	29

## Reference

Using an external unit .....	29
Troubleshooting guide .....	30
Maintenance .....	30
Servicenter List (U.S.A.) .....	31
Specifications .....	Back Cover
Product Service .....	Back Cover

- AM loop antenna (RSA0029-L) ..... 1 pc.       Batteries ..... 2 pcs.  
(R6, AA, UM-3)

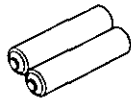
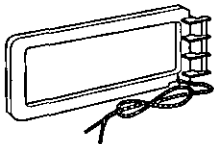

- Remote control transmitter ..... 1 pc.

- SC-AK44: (N2QAGB000004)
- SC-AK33, SC-AK22: (Silver: N2QAGB000002) (Black: N2QAGB000010)



## THE FOLLOWING APPLIES ONLY IN THE U.S.A.:

### CAUTION:

This equipment has been tested and found to comply with the limits for a Class B digital device, pursuant to Part 15 of the FCC Rules.

These limits are designed to provide reasonable protection against harmful interference in a residential installation. This equipment generates, uses and can radiate radio frequency energy and, if not installed and used in accordance with the instructions, may cause harmful interference to radio communications. However, there is no guarantee that interference will not occur in a particular installation. If this equipment does cause harmful interference to radio or television reception, which can be determined by turning the equipment off and on, the user is encouraged to try to correct the interference by one or more of the following measures:

- Reorient or relocate the receiving antenna.
- Increase the separation between the equipment and receiver.
- Connect the equipment into an outlet on a circuit different from that to which the receiver is connected.
- Consult the dealer or an experienced radio/TV technician for help.

Any unauthorized changes or modifications to this equipment would void the user's authority to operate this device.

This device complies with Part 15 of the FCC Rules. Operation is subject to the following two conditions: (1) This device may not cause harmful interference, and (2) this device must accept any interference received, including interference that may cause undesired operation.

**CAUTION**

RISK OF ELECTRIC SHOCK  
DO NOT OPEN

CAUTION: TO REDUCE THE RISK OF ELECTRIC SHOCK, DO NOT REMOVE SCREWS. NO USER-SERVICEABLE PARTS INSIDE. REFER SERVICING TO QUALIFIED SERVICE PERSONNEL.



The lightning flash with arrowhead symbol, within an equilateral triangle, is intended to alert the user to the presence of uninsulated "dangerous voltage" within the product's enclosure that may be of sufficient magnitude to constitute a risk of electric shock to persons.



The exclamation point within an equilateral triangle is intended to alert the user to the presence of important operating and maintenance (servicing) instructions in the literature accompanying the appliance.

# PRECAUTIONS

Before using this unit please read these operating instructions carefully. Take special care to follow the warnings indicated on the unit itself as well as the safety suggestions listed below. Afterwards keep them handy for future reference.

## Safety

- 1. Power Source**—The unit should be connected to power supply only of the type described in the operating instructions or as marked on the unit.
- 2. Polarization**—If the unit is equipped with a polarized AC power plug (a plug having one blade wider than the other), that plug will fit into the AC outlet only one way. This is a safety feature. If you are unable to insert the plug fully into the outlet, try reversing the plug. If the plug should still fail to fit, contact your electrician to replace your obsolete outlet. Do not defeat the safety purpose of the polarized plug.
- 3. Power Cord Protection**—AC power supply cords should be routed so that they are not likely to be walked on or pinched by items placed upon or against them. Never take hold of the plug or cord if your hand is wet, and always grasp the plug body when connecting or disconnecting it.
- 4. Nonuse Periods**—When the unit is not used, turn the power off. When left unused for a long period of time, the unit should be unplugged from the household AC outlet.

## Installation

### Environment

- 1. Outdoor Antenna Grounding**—If an outside antenna is connected to the receiver, be sure the antenna system is grounded so as to provide some protection against voltage surges and built-up static charges. Section 810 of the National Electrical Code, ANSI/NFPA No. 70-1990, provides information with respect to proper grounding of the mast and supporting structure, grounding of the lead-in wire to an antenna discharge unit, size of grounding conductors, location of antenna-discharge unit, connection to grounding electrodes, and requirements for the grounding electrode. See figure below.

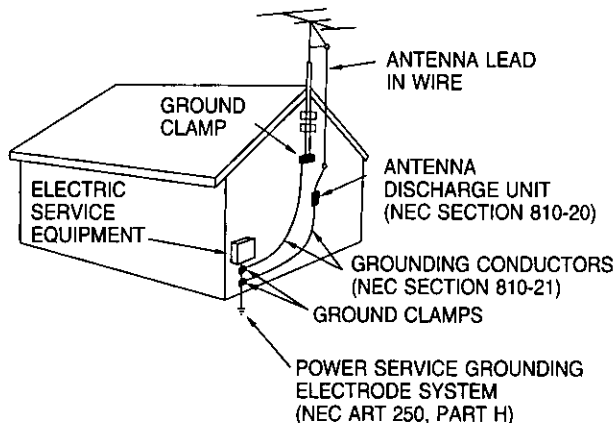

NEC—NATIONAL ELECTRICAL CODE

- 2. Water and Moisture**—Do not use this unit near water—for example, near a bathtub, washbowl, swimming pool, or the like. Damp basements should also be avoided.

- 3. Heat**—The unit should be situated away from heat sources such as radiators and the like. It also should not be placed in temperatures less than 5°C (41°F) or greater than 35°C (95°F).
- 4. Condensation**—Moisture may form on the lens in the following conditions...
  - immediately after a heater has been turned on.
  - in a steamy or very humid room.
  - when the unit is suddenly moved from a cold environment to a warm one.If moisture forms inside this unit, it may not operate properly. To correct this problem, turn on the power and wait about one hour for the moisture to evaporate.

### Placement

- 1. Ventilation**—The unit should be situated so that its location or position does not interfere with its proper ventilation. Allow 10 cm (4") clearance from the rear of the unit.
- 2. Foreign Material**—Care should be taken so that objects do not fall into and liquids are not spilled into the unit. Do not subject this unit to excessive smoke, dust, mechanical vibration, or shock.
- 3. Magnetism**—The unit should be situated away from equipment or devices that generate strong magnetic fields.
- 4. Stacking**—Do not place heavy objects, other than system components, on top of the unit.
- 5. Surface**—Place the unit on a flat, level surface.
- 6. Carts and Stands**—The unit should be used only with a cart or stand that is recommended by the manufacturer. The unit and cart combination should be moved with care. Quick stops, excessive force, and uneven surfaces may cause the unit and cart combination to overturn.
- 7. Wall or Ceiling Mounting**—The unit should not be mounted to a wall or ceiling, unless specified in this operating instructions.

## Maintenance

(See page 30 for details.)

Clean the cabinet, panel and controls with a soft cloth lightly moistened with mild detergent solution. Do not use any type of abrasive pad, scouring powder or solvent such as alcohol or benzene.

## Service

- 1. Damage Requiring Service**—The unit should be serviced by qualified service personnel when:
  - (a) The AC power supply cord or the plug has been damaged;
  - (b) Objects have fallen or liquid has been spilled into the unit;
  - (c) The unit has been exposed to rain;
  - (d) The unit does not appear to operate normally or exhibits a marked change in performance;
  - (e) The unit has been dropped, or the enclosure damaged.
- 2. Servicing**—The user should not attempt to service the unit beyond that described in the operating instructions. All other servicing should be referred to an authorized service personnel.

**For the address of an authorized servicenter:**

**In the U.S.A., call 1-800-211-7262, e-mail  
consumerproducts@panasonic.com, or visit  
www.panasonic.com**

**In Canada, call 905-624-5505 or visit www.panasonic.ca**

## Concerning the remote control

## Battery installation

SC-AK44

SC-AK33 SC-AK22

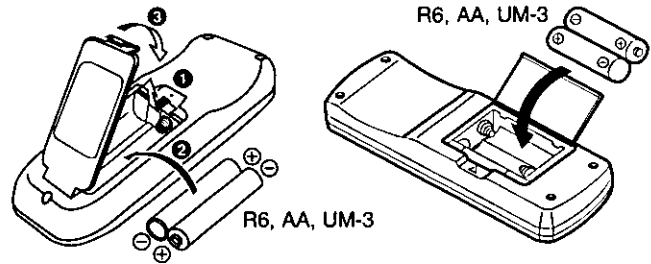

Insert the batteries observing the correct polarities (+, -).

## Use of batteries

- Align the poles (+ and -) properly when inserting the batteries.
- Do not mix old and new batteries or different types of batteries.
- Do not recharge ordinary dry cell batteries.
- Do not heat or disassemble the batteries. Do not allow them to contact flame or water.
- Remove the batteries if the unit is not to be used for a long time.
- Do not keep together with metallic objects such as necklaces.
- Do not use rechargeable type batteries.
- Do not use batteries if the covering has been peeled off.

Mishandling of batteries can cause electrolyte leakage which can damage items the fluid contacts and may cause a fire. If electrolyte leaks from the batteries, consult your dealer. Wash thoroughly with water if electrolyte comes in contact with any part of your body.

## Correct method of use

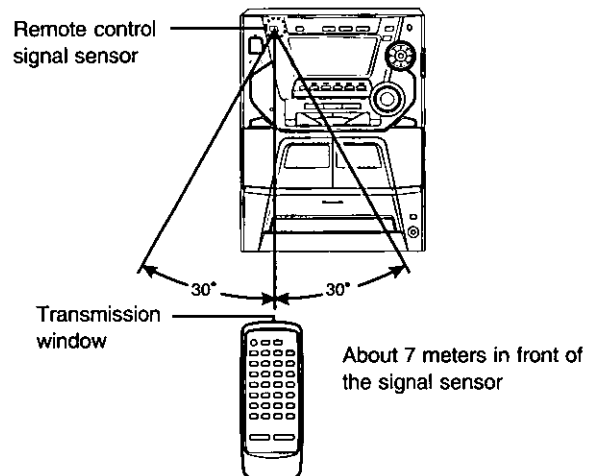

## Operation notes

- Do not place obstacles between the remote control signal sensor and remote control unit.
- Do not expose the remote control signal sensor to direct sunlight or to the bright light of a fluorescent light.
- Take care to keep the remote control signal sensor and end of the remote control unit free from dust.
- If this system is installed in a rack with glass doors, the glass doors' thickness or color might make it necessary to use the remote control a shorter distance from the system.

## To prevent damage

- Never place heavy items on top of the unit.
- Do not disassemble or reconstruct the unit.
- Do not spill water or other liquids into the unit.

## Listening caution



Selecting fine audio equipment such as the unit you've just purchased is only the start of your musical enjoyment. Now it's time to consider how you can maximize the fun and excitement your equipment offers. This manufacturer and the Electronic Industries Association's Consumer Electronics Group want you to get the most out of your equipment by playing it at a safe level. One that lets the sound come through loud and clear without annoying blaring or distortion—and, most importantly, without affecting your sensitive hearing.

We recommend you to avoid prolonged exposure to excessive noise.

Sound can be deceiving. Over time your hearing "comfort level" adapts to higher volumes of sound. So what sounds "normal" can actually be loud and harmful to your hearing. Guard against this by setting your equipment at a safe level BEFORE your hearing adapts.

To establish a safe level:

- Start your volume control at a low setting.
- Slowly increase the sound until you can hear it comfortably and clearly, and without distortion.

Once you have established a comfortable sound level:

- Set the dial and leave it there.

Taking a minute to do this now will help to prevent hearing damage or loss in the future. After all, we want you listening for a lifetime.

## Placement of speakers

Place the speakers so that the super woofer is on the outside.

SC-AK44

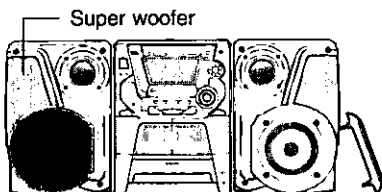

SC-AK33

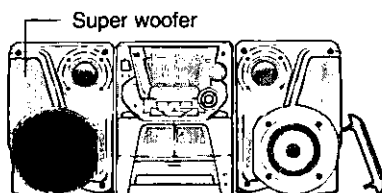

Speakers are designed identically so that no left or right channel orientation is necessary.

SC-AK22

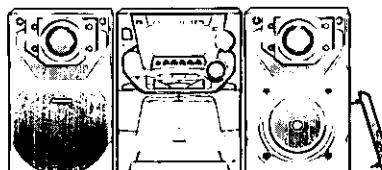

## Notes

- Keep your speakers at least 10mm ( $13/32$ ) away from the system for proper ventilation.
- These speakers do not have magnetic shielding. Do not place them near televisions, personal computers or other devices easily influenced by magnetism.
- To avoid damage to the speakers, do not touch the speaker cones if you have taken the nets off.

Before using

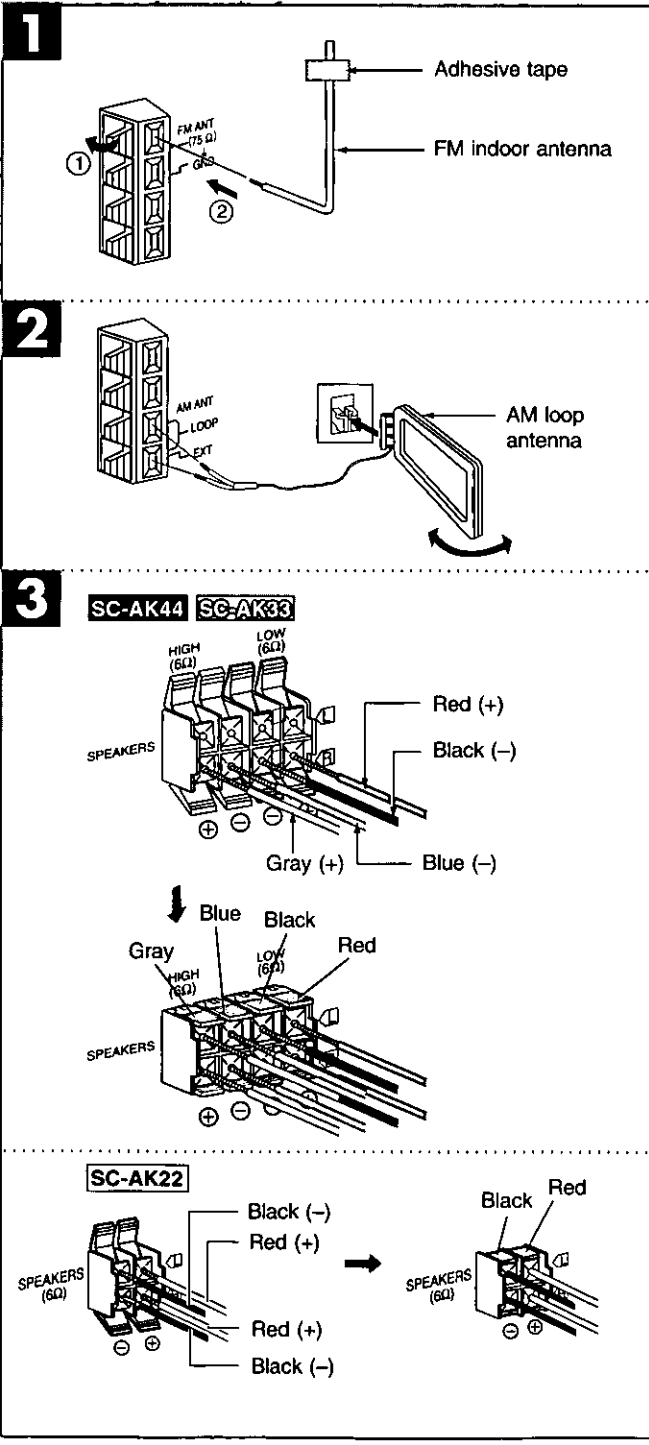
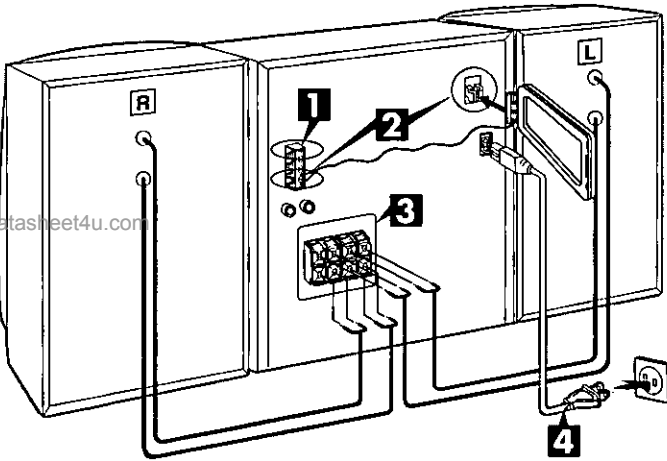

## Connections

### Basic connections (for supplied accessories)

- Plug the AC power cord into a household AC outlet only after all other connections have been made.
- To prepare the antenna wires and speaker cords, twist the vinyl cover tip and pull off.

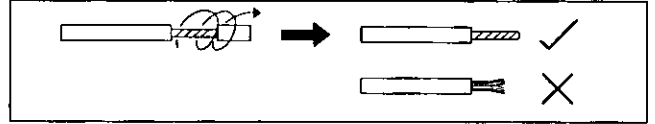

- 1 Connect the FM indoor antenna.**  
Tape the antenna to a wall or column, in a position where radio signals are received with the least amount of interference.

**Note**

**For best reception sound quality:**  
An FM outdoor antenna is recommended. (See page 7.)

- 2 Connect the AM loop antenna.**  
After attaching the antenna, turn on the system and tune in a broadcast station. Then, turn the antenna to the angle of best reception and least interference.

- 3 Connect the speaker cables.**  
Connect each end of the speaker cables to the terminal lever of the same color so (+) and (-) are correct. Never allow the exposed wires to contact each other when connected.  
**Incorrect connection can damage the unit.**

**Caution**

- **Use only the supplied speakers.**  
The combination of the main unit and speakers provide the best sound. Using other speakers can damage the unit and sound quality will be negatively affected.

!

**Caution**

- **Use the speakers only with the recommended system.**  
Failure to do so may lead to damage to the amplifier and/or the speakers, and may result in the risk of fire.
- **Consult a qualified service person if damage has occurred or if you experience a sudden change in performance.**
- **Do not attach these speakers to walls or ceilings.**

- 4 Connect the AC power cord.**  
**Note**  
The included AC power supply cord is for use with this unit only. Do not use it with other equipment.

## Connections

### Optional antenna connections

You may need an outdoor antenna if you use this system in a mountainous region or inside a reinforced-concrete building, etc.

#### A FM outdoor antenna

Disconnect the FM indoor antenna if an FM outdoor antenna is installed.

- 1 Remove a piece of the outer vinyl insulator.
- 2 Twist the shield braid.
- 3 Expose the core wire.

#### Note

An outdoor antenna should be installed by a qualified technician only.

#### B AM outdoor antenna

Connect the outdoor antenna without removing the AM loop antenna. Run 5 to 12 m of vinyl-covered wire horizontally along a window or other convenient location.

#### Note

When the unit is not in use, disconnect the outdoor antenna to prevent possible damage that may be caused by lightning. Never use an outdoor antenna during an electrical storm.

#### C External unit connection

- An analog player with a built-in phono equalizer can be connected.
- For details, refer to the instruction manual of the units which are to be connected.
- When units other than those described above are to be connected, please consult with your audio dealer.

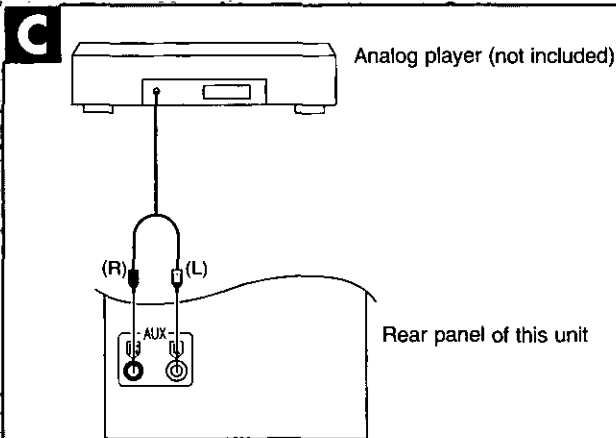
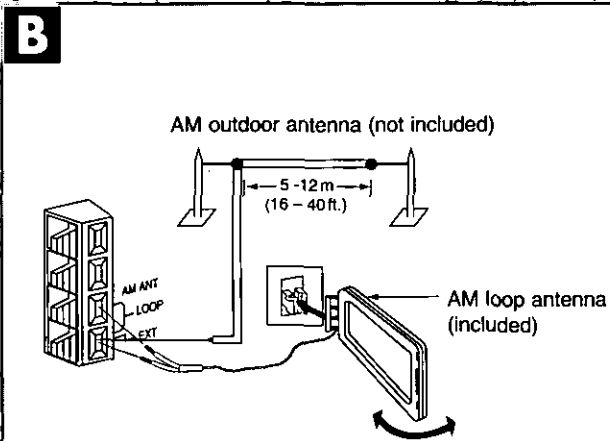
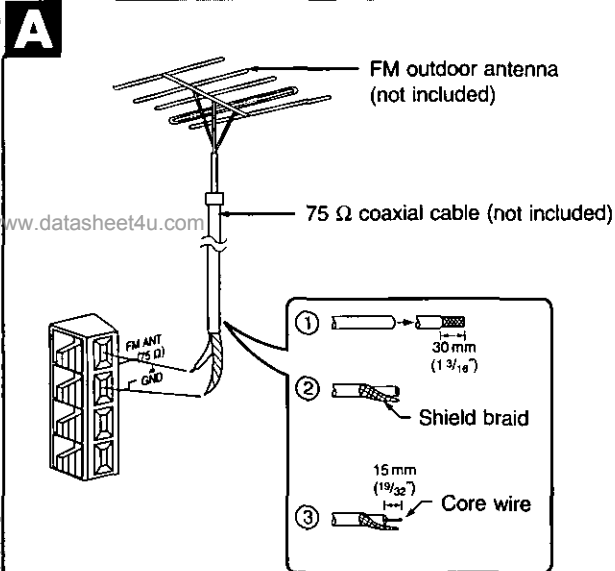

**A**

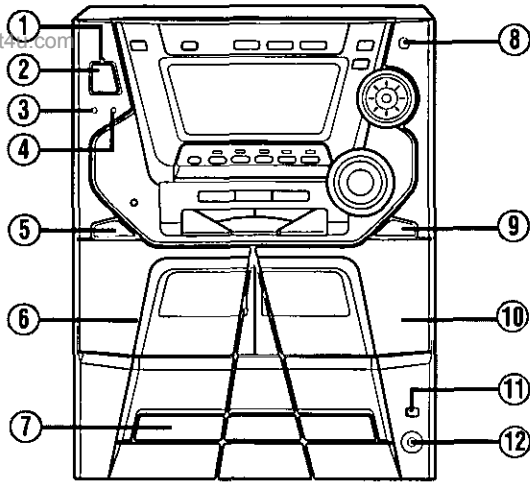

**B**

**SC-AK44**

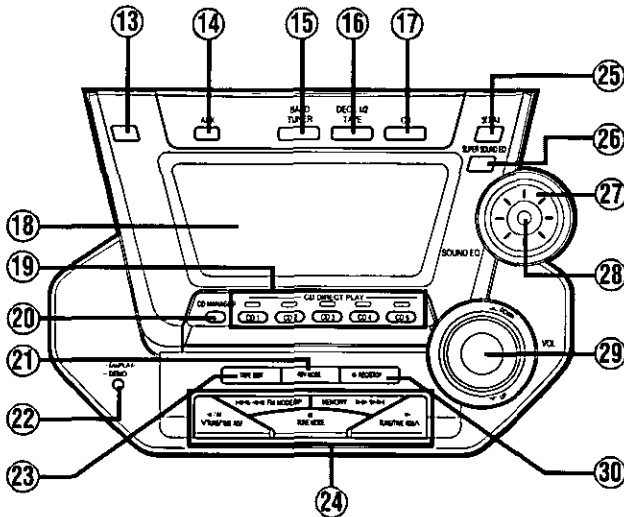

**SC-AK33 SC-AK22**

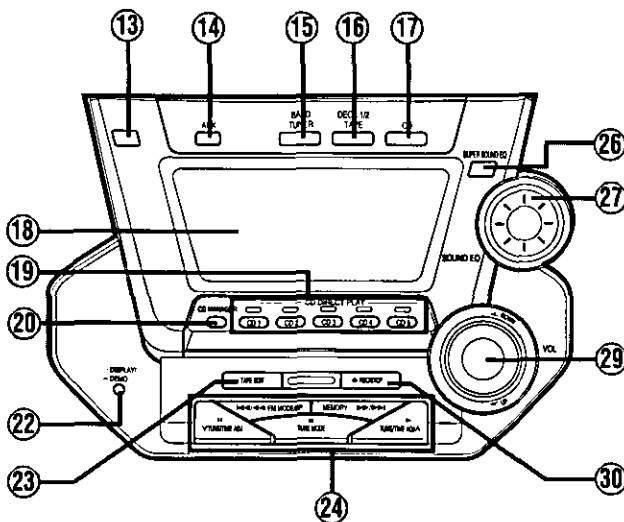

**Front panel controls**

**A Main unit**

No.	Name	Ref. page
①	<b>AC supply indicator (AC IN)</b> This indicator lights when the unit is connected to the AC power supply.	
②	<b>Standby/on switch (⏻/⏻, POWER)</b> ..... 11 Press to switch the unit from on to standby mode or vice versa. In standby mode, the unit is still consuming a small amount of power.	11
③	<b>Play timer/record timer button (⏻/⏻)</b> ..... 27	27
④	<b>Clock/timer button (CLOCK/TIMER)</b> ..... 11, 27, 28	11, 27, 28
⑤	<b>Deck 1 open button (⏻ DECK 1 OPEN)</b> ..... 19	19
⑥	<b>Deck 1 cassette holder</b> ..... 19	19
⑦	<b>Disc tray</b>	
⑧	<b>SC-AK44 and SC-AK33 only</b> <b>Super woofer on/off button (S.WOOFER)</b> ..... 25	25
⑨	<b>Deck 2 open button (⏻ DECK 2 OPEN)</b> ..... 19	19
⑩	<b>Deck 2 cassette holder</b> ..... 19	19
⑪	<b>CD open/close button (⏻, OPEN/CLOSE)</b> ..... 15	15
⑫	<b>Headphone jack (PHONES)</b> ..... 29	29

**B Center console**

⑬	<b>Remote control signal sensor</b> ..... 5	5
⑭	<b>AUX button (AUX)</b> ..... 29	29
⑮	<b>Tuner/band select button (TUNER, BAND)</b> ..... 12	12
⑯	<b>Tape/deck select button (TAPE, DECK 1/2)</b> ..... 19	19
⑰	<b>CD button (CD)</b> ..... 18	18
⑱	<b>Display</b>	
⑲	<b>Disc direct play buttons and indicators (CD 1 ~ CD 5)</b> ..... 15	15
⑳	<b>CD manager button (CD MANAGER)</b> ..... 18, 24	18, 24
㉑	<b>SC-AK44 only</b> <b>Reverse mode select button (REV MODE)</b> ..... 19	19
㉒	<b>Display select/demonstration button (-DISPLAY/-DEMO)</b> ..... 10, 11	10, 11
㉓	<b>Tape edit button (TAPE EDIT)</b> ..... 21	21
㉔	<b>Basic operating buttons</b> Functions change according to the source.	
㉕	<b>SC-AK44 only</b> <b>3D AI button (3D AI)</b> ..... 26	26
㉖	<b>Super sound EQ button (SUPER SOUND EQ)</b> ..... 25	25
㉗	<b>Jog control (SOUND EQ)</b> ..... 25	25
㉘	<b>SC-AK44 only</b> <b>Joy stick (SOUND EQ)</b> ..... 26	26
㉙	<b>Volume control (VOL)</b> ..... 12	12
㉚	<b>Recording start/stop button (● REC/STOP)</b> ..... 22	22



SC-AK44

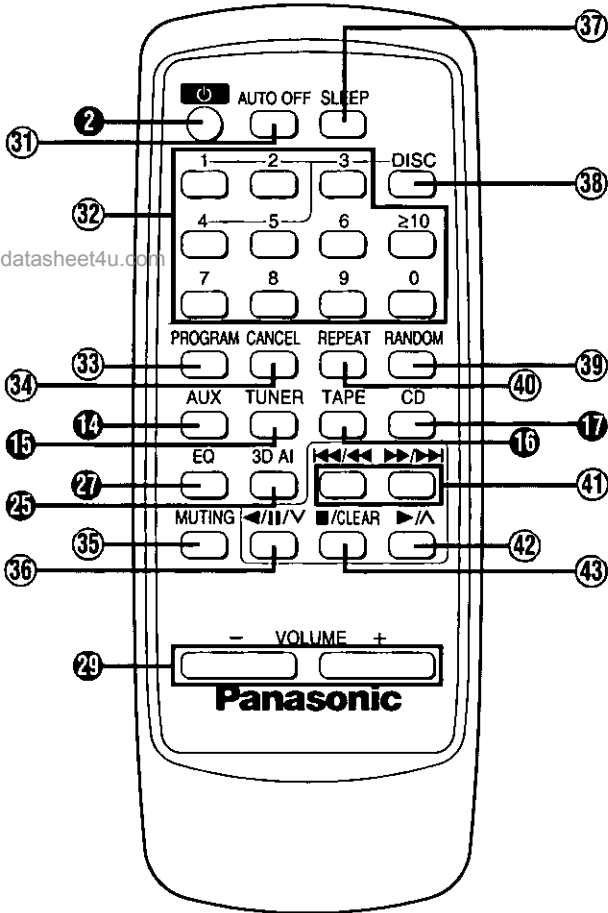

SC-AK33 SC-AK22

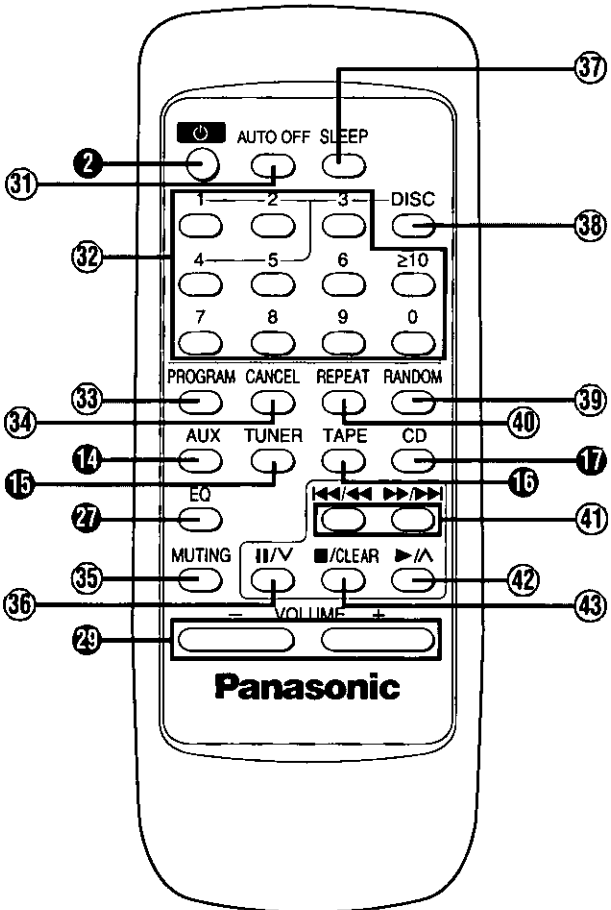

## Front panel controls

### Remote control

Buttons such as 2 functions in exactly the same way as the buttons on the main unit.

No.	Name	Ref. page
2	Standby/on button (⏻)	11
31	Auto off button (AUTO OFF)	10
32	Numeric buttons (≥10, 1-9, 0)	13, 16
33	Program button (PROGRAM)	17
34	Cancel button (CANCEL)	17
14	AUX button (AUX)	29
15	Tuner/band select button (TUNER)	12
27	EQ select button (EQ)	25
25	SC-AK44 only 3D AI select button (3D AI)	26
35	Muting button (MUTING)	11
36	SC-AK44 Reverse side playback/pause/preset channel select button (⏮/⏪/⏩/⏭)	13, 15, 19
	SC-AK33 SC-AK22 Pause/preset channel select button (⏪/⏩)	13, 15
29	Volume buttons (- VOLUME +)	12
37	Sleep button (SLEEP)	29
38	Disc button (DISC)	16
39	Random button (RANDOM)	16
40	Repeat button (REPEAT)	16
17	CD button (CD)	17
16	Tape/deck select button (TAPE)	19
41	Skip/search buttons (⏮/⏪/⏩/⏭)	15, 20
42	Play/preset channel select button (▶/⏭)	13, 15, 19
43	Stop/program clear button (■/CLEAR)	15, 17, 19

**A**

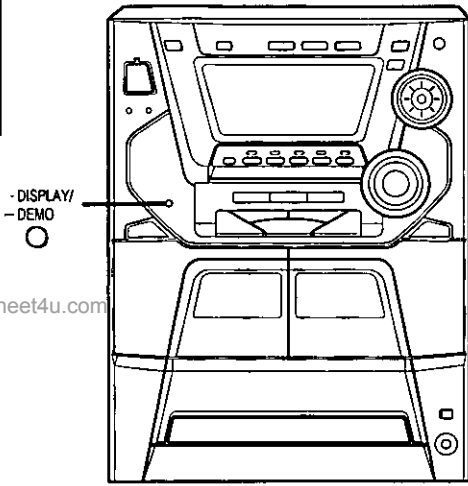

www.datasheet4u.com

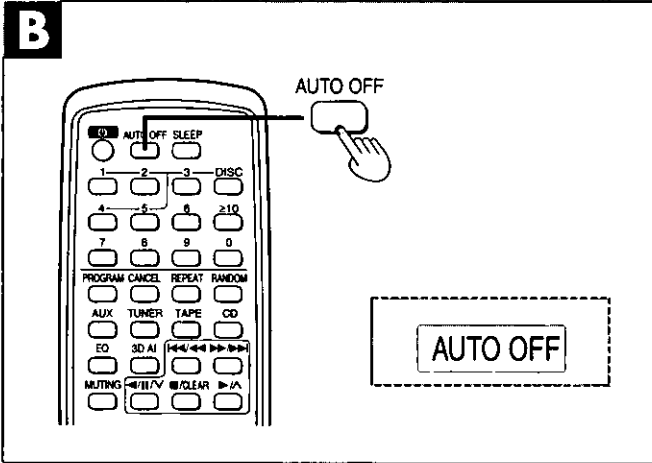
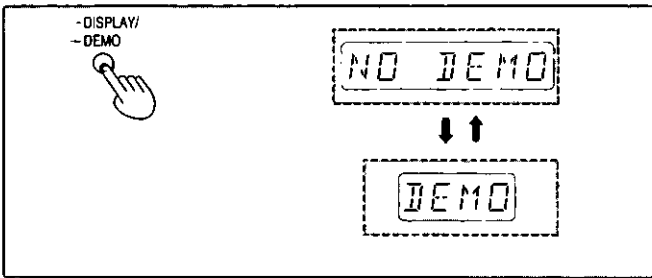

**A Turning the demo function off**

If the clock has not been set, a demonstration of the display is shown when the unit is switched to standby. This function is set to on at the time of purchase.

**Press and hold [-DISPLAY/-DEMO] until "NO DEMO" is displayed.**

The display changes each time the button is held down. NO DEMO (off) ↔ DEMO (on)

**B Auto-off function**

**by remote control only**

When CD or tape is selected as the source To save power, the unit turns off if it is left unused for ten minutes.

**Note**

This function does not work if the source is tuner or AUX.

**Press [AUTO OFF].**

"AUTO OFF" is shown on the display.

**To cancel**

Press [AUTO OFF] again to clear "AUTO OFF" from the display.

**For your reference**

The setting is maintained even if the unit is turned off. When the unit is turned on again, "AUTO OFF" is displayed and the unit functions as described above.

"AUTO OFF" disappears from the display if either tuner or AUX is selected as the source but continues to function normally.

"AUTO OFF" remains displayed if CD or tape is selected as the source.

## Setting the time

This is a 12-hour display clock.  
This example in the figure shows how to set the time for 4:25 p.m..

- 1** Switch on the power.
- 2** Press [CLOCK/TIMER] to select "CLOCK".  
Every time you press the button:  
CLOCK → ⓄPLAY → ⓄREC  
↑ Previous display ↓
- 3** (within 7 seconds or so)  
Press [TUNE/TIME ADJ (V) or (^)] to show the present time.
- 4** Press [CLOCK/TIMER] to finish setting the time.  
The display will return to whatever was displayed before you set the time.

**To display the time when system is ON**  
Press [CLOCK/TIMER] to select "CLOCK".

**To display the time when system is OFF**  
Press [CLOCK/TIMER].

The time will be displayed for about 5 seconds and then the display will return to whatever was previously displayed.

### Note

The clock may lose or gain some time over a period. Readjust if necessary.

## Convenient functions

### A Switching displays

Press [-DISPLAY/-DEMO] to select the desired spectrum analyzer.

Every time you press the button:

Normal → Peak hold → Aurora  
↑ (OFF) ↓

### B To mute the volume

by remote control only

This feature is convenient when you have a telephone call, etc.

Press [MUTING].

Press the button again to cancel.

"MUTING" goes out.

Muting can also be canceled by lowering the volume all the way (-dB).

When the system is turned off, the muting operation will be automatically canceled.

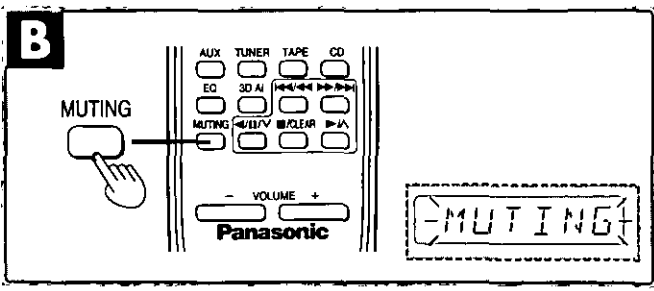
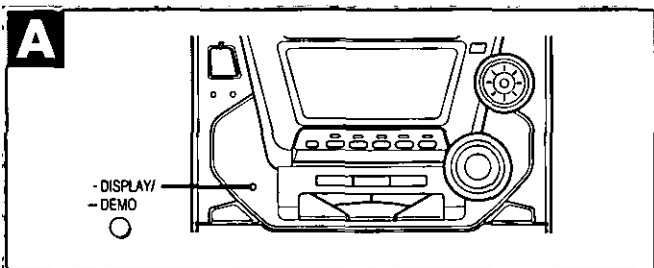
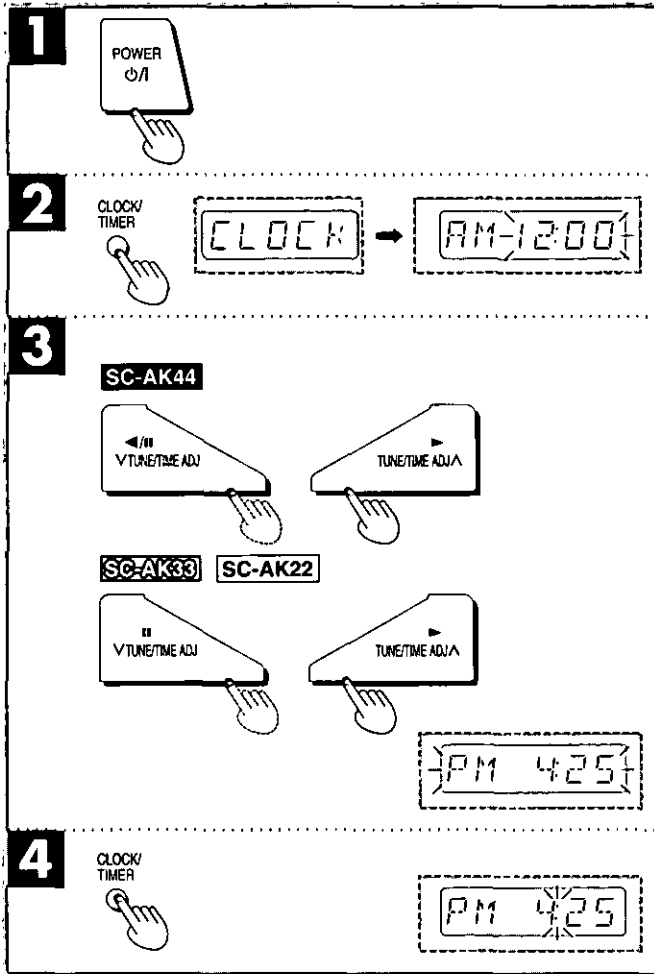
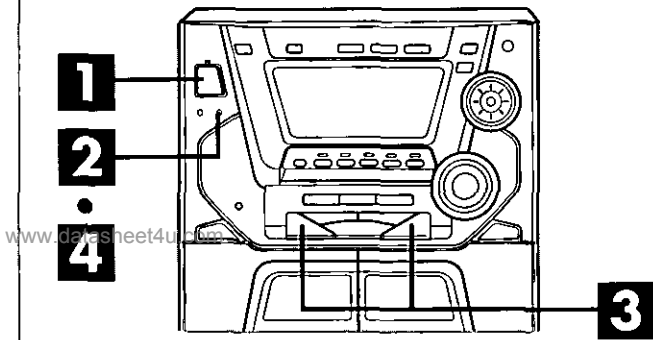

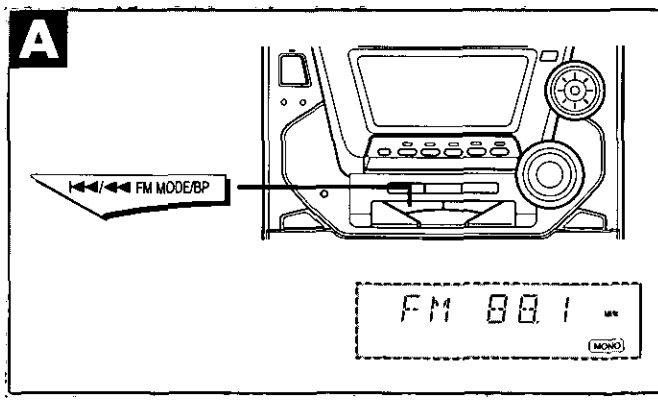
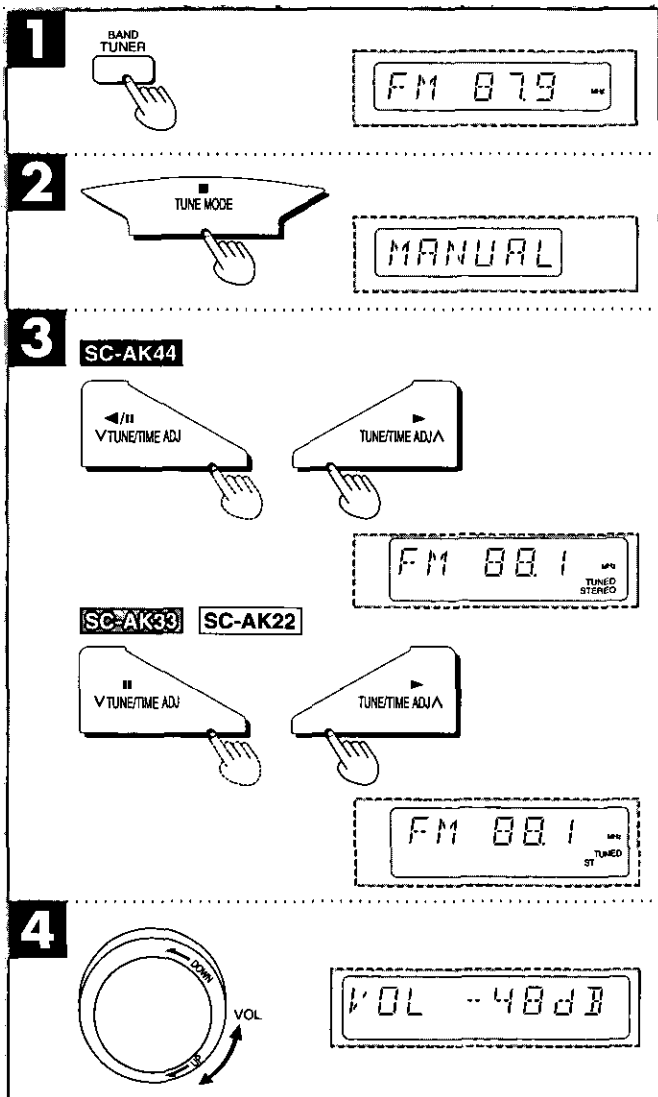
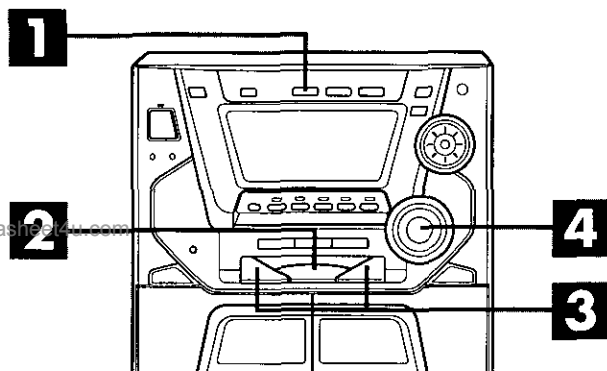

## Listening to radio broadcasts

- 1** Press [TUNER, BAND] to select band.  
The unit comes on automatically.  
Every time you press the button:  
FM ↔ AM
- 2** Press [■, TUNE MODE] to select "MANUAL".  
Every time you press the button:  
MANUAL ↔ PRESET.
- 3** Press [TUNE/TIME ADJ (V) or (^)] to select the frequency of the required station.  
"TUNED" is displayed when a radio station is tuned.  
"STEREO" ("ST" for SC-AK33 and SC-AK22) is displayed when a stereo FM broadcast is being received.
- 4** Adjust the volume.

### Auto tuning

Press and hold [TUNE/TIME ADJ (V) or (^)] for a moment until the frequency starts changing rapidly. The unit begins auto tuning, stopping when it finds a station.

- Auto tuning may not function when there is excessive interference.
- To cancel auto tuning, press [TUNE/TIME ADJ (V) or (^)] once again.

### A If noise is excessive in FM

Press [I◀◀/▶▶ FM MODE/BP] to display "MONO".

This mode improves sound quality if reception is weak, but broadcasts will be heard in monaural.

Press [I◀◀/▶▶ FM MODE/BP] again to cancel the mode.

"MONO" goes out. MONO is also canceled if the frequency is changed.

Turn off "MONO" for normal listening. Stereo and monaural broadcasts are automatically played as they are received.

### FM allocation setting

By adjusting the allocation, you can enable this tuner to receive FM broadcasts allocated in 0.1 MHz steps.

Press and hold [TUNER, BAND]. After a few seconds, the display will change to a flashing display of the current minimum FM frequency.

If you continue to hold the button down, the minimum frequency will change. Release the button at this time.

To return to the original frequency indication, repeat above.

### Note

- After changing the "allocation" setting, the frequencies you previously preset in the memory will be cleared.
- Sound is momentarily interrupted if you load/unload tapes while listening to an AM broadcast.

## Presetting radio broadcasts

There are two methods of presetting stations.

**Automatic presetting** : All the stations the tuner can receive are preset.

**Manual presetting** : You can select the stations to preset and the order they are preset in.

Up to 12 stations each can be set in the FM and AM bands.

### A Automatic presetting

Do the following once each for FM and AM.

**Preparation:**

- Tune to the frequency where presetting is to begin (⇒ page 12).

**Press and hold [MEMORY ►►►►].**

Release the button when frequency begins to change.

The tuner presets all the stations it can receive into the channels in ascending order. When finished, the last station memorized is tuned in.

### Manual presetting

Preset the stations one at a time.

- 1 Press [TUNER, BAND] to select the "FM" or "AM".
- 2 Press [MEMORY ►►►►] then press [TUNE/TIME ADJ (V) or (^)] to tune to the required station.
- 3 Press [MEMORY ►►►►] then press [TUNE/TIME ADJ (V) or (^)] to tune to select a channel.
- 4 Press [MEMORY ►►►►].

The station occupying a channel is erased if another station is preset in that channel.

### B Selecting channels

by remote control

- 1 Press [TUNER] to select "FM" or "AM".  
The unit comes on automatically.  
Every time you press the button:  
FM ↔ AM
- 2 Press the numbered buttons to select the channel.  
• To select channel 10 or over  
Press [≥10] then the two digits.
- 3 Adjust the volume.

On the main unit

- 1 Press [TUNER, BAND] to select "FM" or "AM".
- 2 Press [■, TUNE MODE] to select "PRESET".
- 3 Press [TUNE/TIME ADJ (V) or (^)] to select the preset channel.

A

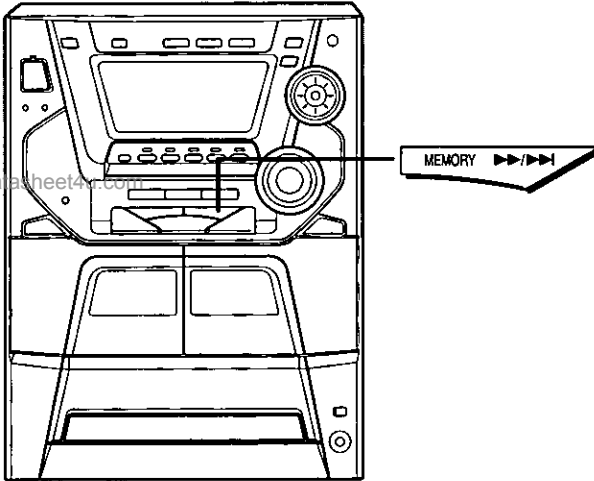

www.dataSheet4U.com

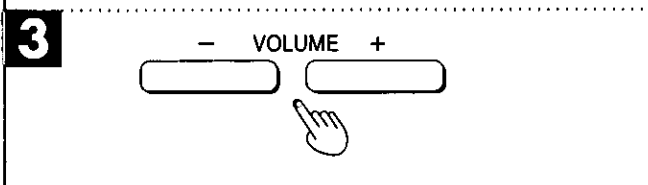
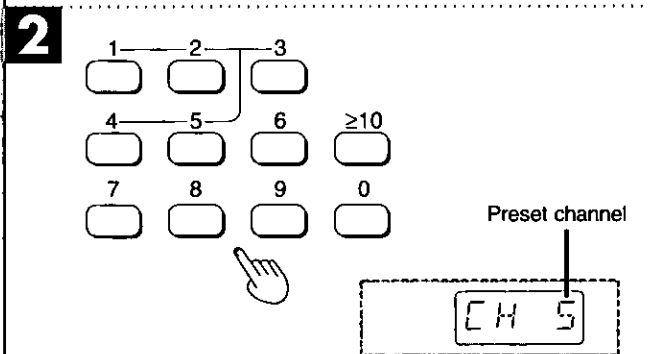
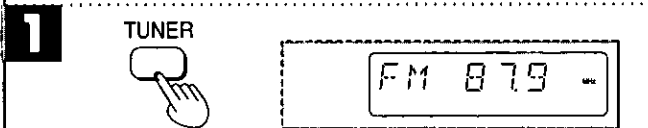
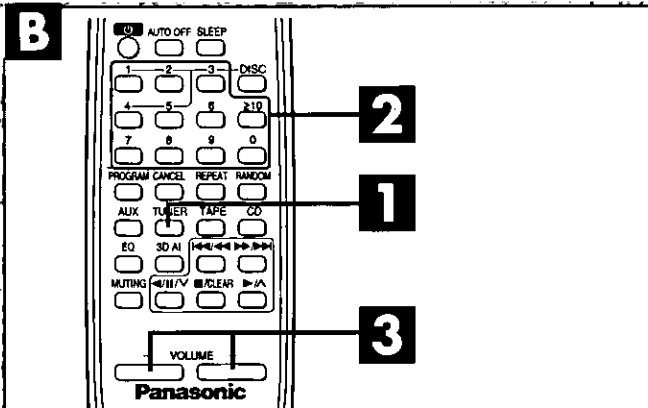
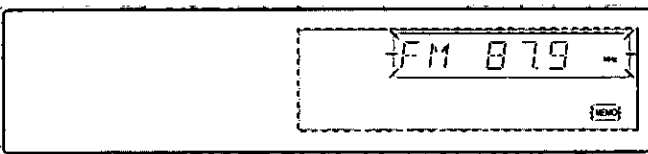

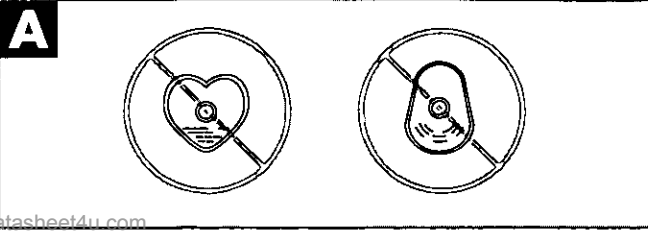

www.datasheet4u.com

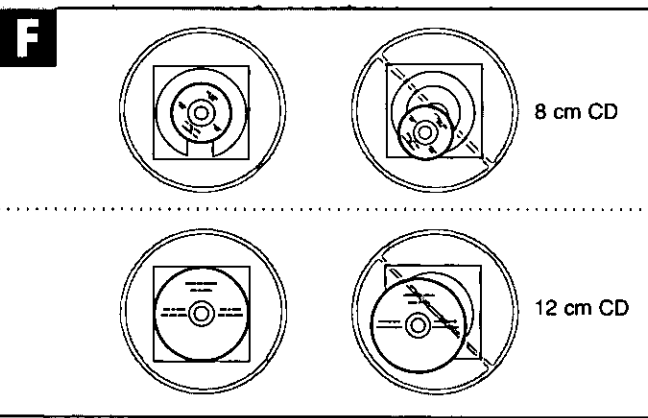
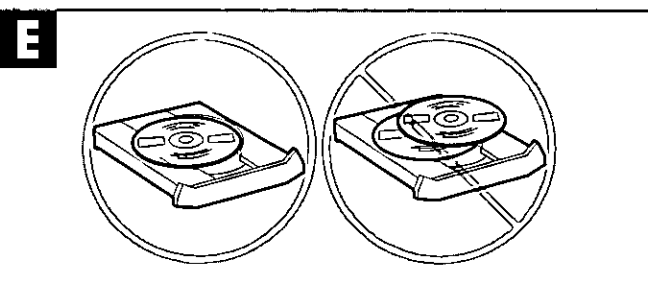
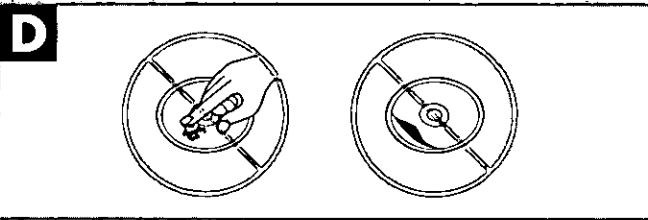
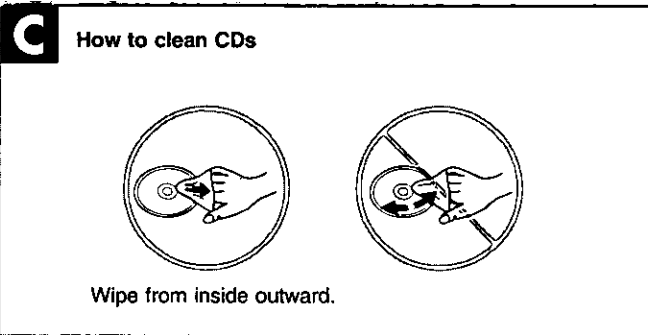
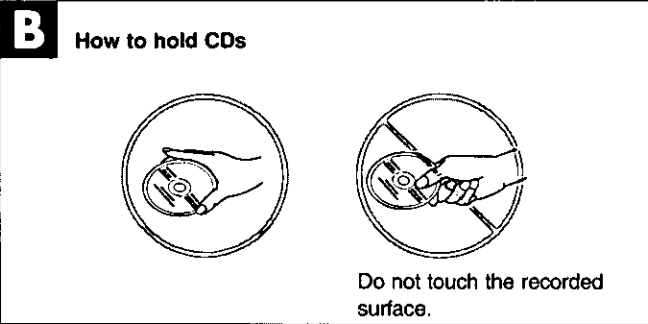

## Concerning compact discs

With this system, you can only play compact discs having this mark.



**A** However, do not use irregular shaped CDs. CDs of the sort can damage the unit.

## B ~ D Handling precautions

- If you are taking the disc from a cold to a warm environment, moisture may form on the disc. Wipe this off with a soft, dry, lint-free cloth before using the disc.
- Do not write on the label side with a ball-point pen or other writing instrument.
- Do not use record cleaning sprays, benzine, thinner, static electricity prevention liquids or any other solvent.
- Do not attach labels or stickers to CDs. (Do not use CDs with exposed adhesive from tape or left over peeled off stickers.)
- Do not use scratch-proof protectors or covers other than those specified for use with this system.
- Do not use CDs printed with label printers available on the market.

## Storage precautions

Be sure to store discs in their cases to protect them from dust, scratches, and warping.

**Do not place or store discs in the following places**

- Locations exposed to direct sunlight
- Humid or dusty locations
- Locations directly exposed to a heat vent or heating appliance
- In the glove compartment or on the rear deck of an automobile

## To prevent damage

Always observe the following points.

- **E** Load only 1 CD on the tray.
- **F** Load CDs as shown in the figure. The adapter is not needed with 8 cm CDs (singles).
- Set the system on a flat, level surface. Do not set it on top of magazines, inclined surfaces, etc.
- Do not move the system while tray is opening/closing, or when loaded. Always unload all CDs before moving the system.
- Do not put anything except CD in tray.
- Do not use cleaning CDs or CDs which are badly warped or cracked.
- Do not disconnect the power cord from the household AC outlet during disc changing operation.

## Listening to compact discs

This unit can play CD-DA format audio CD-R and CD-RW that have been finalized\* upon completion of recording. It may not be able to play some CD-R or CD-RW due to the condition of the recording.

\* Finalizing is a process that enables CD-R/CD-RW players to play audio CD-R and CD-RW.

- 1** Press [**△**, OPEN/CLOSE] button.  
The unit will come on automatically and the tray opens.
- 2** Set CD in the tray.  
To continue loading CDs in the other trays  
Press another [(CD 1) ~ (CD 5)] to select the required tray and press [**△**, OPEN/CLOSE] to open the tray.  
The current tray closes and the selected tray automatically opens.  
Press [**△**, OPEN/CLOSE] to close the tray.
- 3** Press [(CD 1) ~ (CD 5)] to play your desired disc.  
(If the desired CD is indicated on the display panel, the same operation can be accomplished by pressing [**▶**].)  
Play will start from the first track on the disc and will continue until the last track of the final disc is played (see below).
- 4** Adjust the volume.

**A** To stop the disc play  
Press [**■**].

**B** When ">" appears on the display  
It indicates there are 13 or more tracks on the disc in the playing position.

### Disc Indicators

The disc indicators light whenever the tray is in the playing position whether it is loaded or not.

### What is meant by "final disc"?

For example, if play starts from disc 4, disc 3 will be the "final disc".

### Order of progression:

Disc 4→5→1→2→3

### One touch play

If the unit is in standby mode and a CD is loaded, press [CD] or [(CD 1) ~ (CD 5)].

The unit will come on automatically and play will start.

<b>To pause</b>	(For SC-AK44) Press [ <b>⏸</b> ] during playback. To resume playback, press [ <b>⏸</b> ].  (For SC-AK33 and SC-AK22) Press [ <b>⏸</b> ] during playback. To resume playback, press [ <b>⏸</b> ].
<b>To search forward/backward (Search)</b>	Hold down [ <b>⏮</b> / <b>⏪</b> ] (backward) or [ <b>⏭</b> / <b>⏩</b> ] (forward) during playback or pause mode.
<b>To skip forward/backward</b>	Press [ <b>⏮</b> / <b>⏪</b> ] (backward) or [ <b>⏭</b> / <b>⏩</b> ] (forward) during playback or pause mode.

### Notes

- During random play (⇒ page 16), you cannot skip to tracks which have already been played.
- During program play (⇒ page 17) or random play, you can search forward or backward only within the current track.
- During program play, skipping is always in the programmed order, whether forward or backward.
- Always stop the changer before loading or changing CDs. You cannot change CDs while a disc is playing.

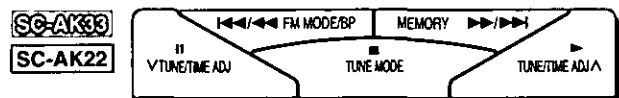
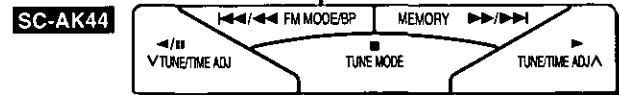
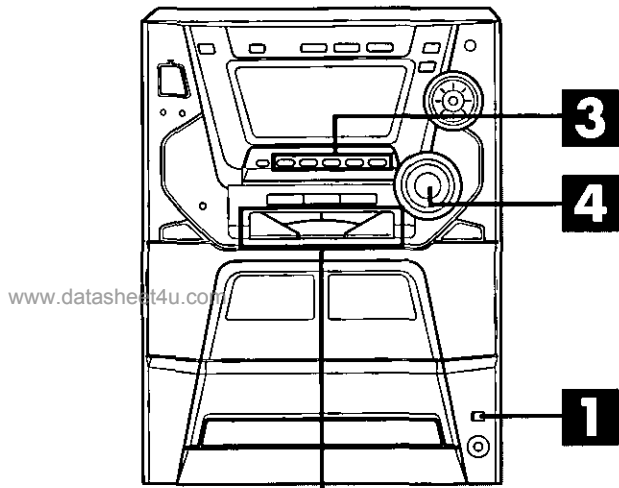

**1** OPEN/CLOSE

---

**2**  
  
Label must face upward.

---

**3**  
  
Track number  
Elapsed playing time (Of current track number)

---

**4**  
  
VOL

---

**A**  
  
Number of tracks  
Disc number Total playing time

---

**B**

www.datasheet4u.com

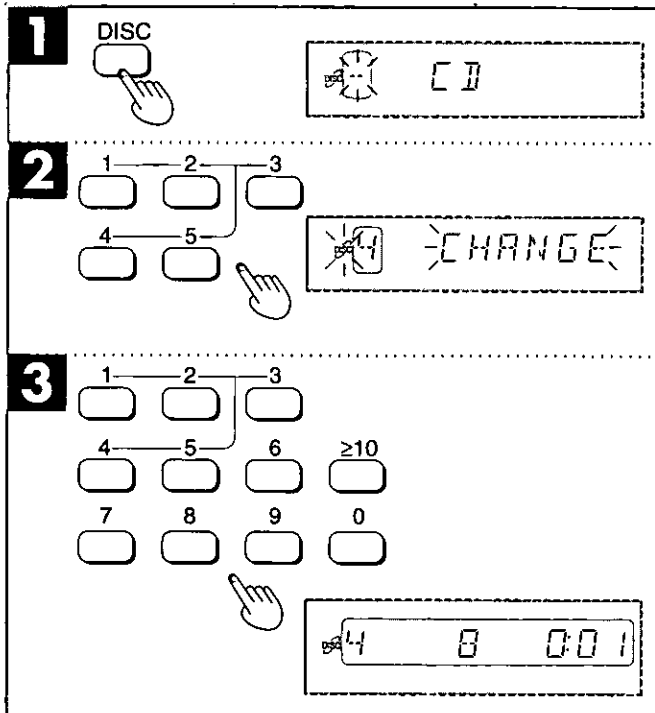
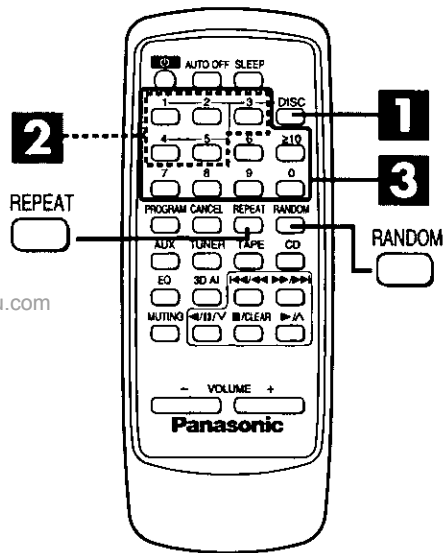

## Listening to compact discs

### Direct access play

by remote control only

- 1** Press [DISC].
- 2** (within 10 seconds or so)  
Press [1] – [5] to select the disc you want.
- 3** Press the numeric button to select the desired track number.  
The CD will be played from the selected track to the last track of the final disc (⇒ page 15).

#### To select a two-digit track

Press [ $\geq 10$ ] and then the two numbers you want within 10 seconds or so.

For example

Track no. 20: [ $\geq 10$ ] → [2] → [0]

Track no. 35: [ $\geq 10$ ] → [3] → [5]

### Repeat play

by remote control only

- A** Press [REPEAT] before or during play.  
All tracks on the loaded CDs are repeated.

#### To cancel repeat play

Press [REPEAT] once again.

#### To repeat your favorite tracks

1. Program the tracks you want (perform steps **1** ~ **6** on page 17).
2. Press [REPEAT] and make sure "CD" is displayed.
3. Press [▶/▲]. Playback will start.

#### To repeat just one track

Set the 1-TRACK mode (⇒ page 18), press [REPEAT] before or during playback, and make sure "CD" is displayed.

### Random play

by remote control only

- B** Press [RANDOM].

Every time you press the button:

1-DISC → ALL-DISC  
 ↑ Previous display ↓

#### To random play just one disc

Select the CD you want to random play with [(CD 1) ~ (CD 5)] and press [RANDOM] to select "1-DISC".

#### To random play all the loaded CDs

Press [RANDOM] to select "ALL-DISC".

All tracks on the CD(s) will be played in random order. Playback will stop automatically when all tracks have been played.

#### To cancel random play

Press [RANDOM] to clear "RANDOM" display.

#### Note

You can use random play with your program. Only the programmed tracks will be played, but in random order.



## Listening to compact discs

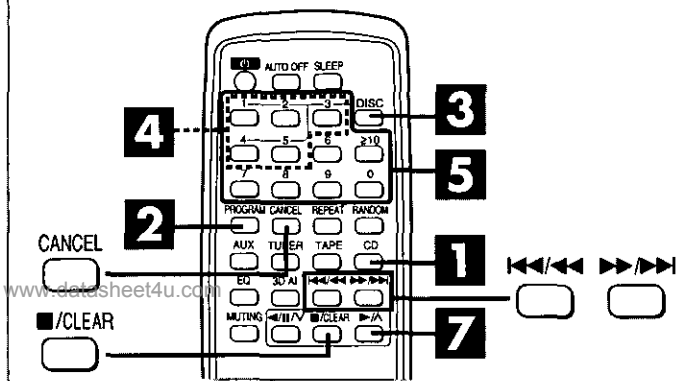

### Program play

#### by remote control only

You can program up to 24 tracks.

- 1** Press [CD].  
Ensure CD is stopped.
- 2** Press [PROGRAM].
- 3** Press [DISC].
- 4** (within 10 seconds or so)  
Press [1] - [5] to select the disc you want.
- 5** Press the numeric button to select the desired track.
- 6** Repeat steps **3** through **5** until you have programmed all the tracks you want.
- 7** Press [▶/▲].  
Play will start in the programmed sequence.

#### To cancel program play mode

Press [PROGRAM] in the stop mode.

Programmed contents will be saved in memory.

Pressing [■/CLEAR] will cancel program play, but it will also erase the entire program.

#### To select a two-digit track

Press [≥10] and then the two numbers you want.

#### A When "CD FULL" appears

The number of programmed tracks is limited to 24. No further tracks can be programmed.

#### B You can do the following during program mode

- Check program contents.  
Press [◀◀/▶▶] or [▶▶/▶▶].  
Every time you press one of the buttons, the track and program No. are shown on the display.
- Add to the program.  
Repeat steps **3** through **5**.
- Cancel entries.

From the last programmed track	Press [CANCEL].
A specified track only	Select the track with [◀◀/▶▶] or [▶▶/▶▶], and press [CANCEL] within 3 seconds.
All tracks	Press [■/CLEAR].

#### Memory retention

Your program is retained in memory for about 2 weeks while the system is unplugged.

#### To replay your program

If you turned OFF your program with [PROGRAM], you can play it again as explained below.

1. Press [PROGRAM].
2. Press [▶/▲].

#### If you program a track not on your CDs

The track is initially programmed, but during program play, the player will skip that track and will continue playing from the next programmed item.

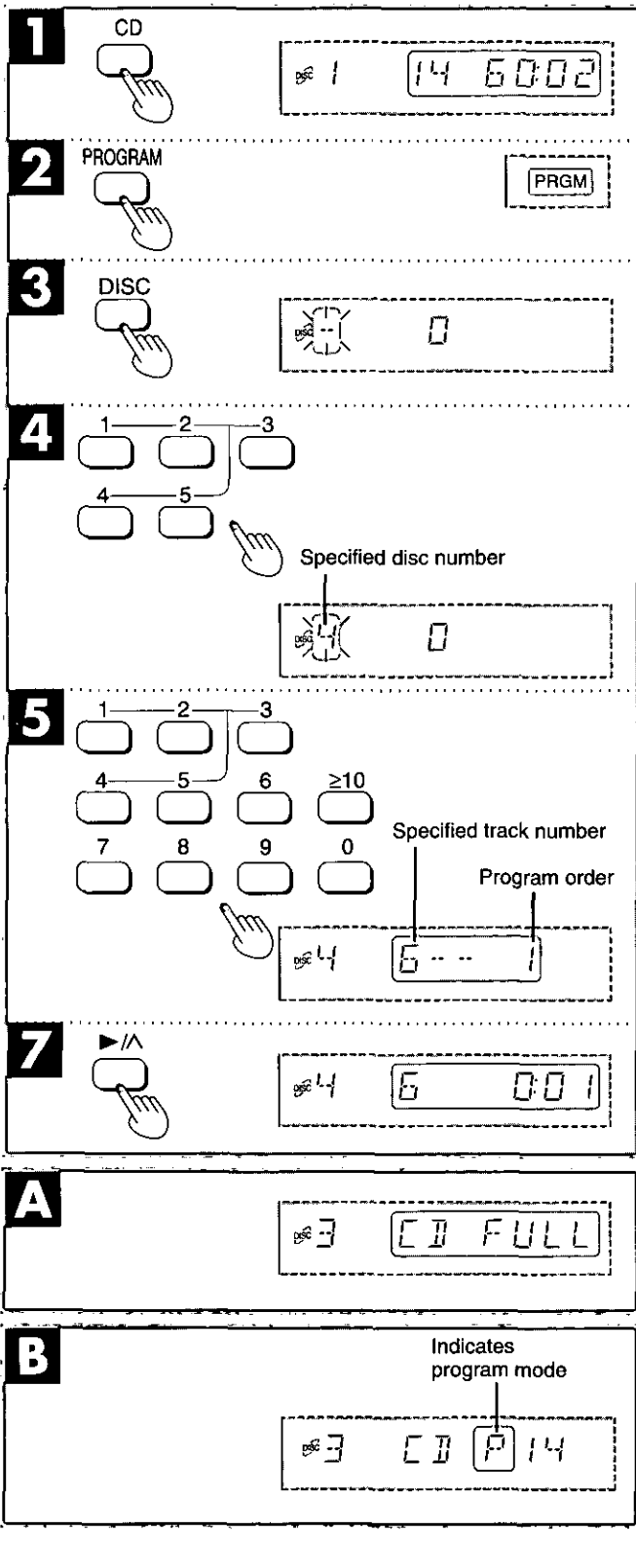

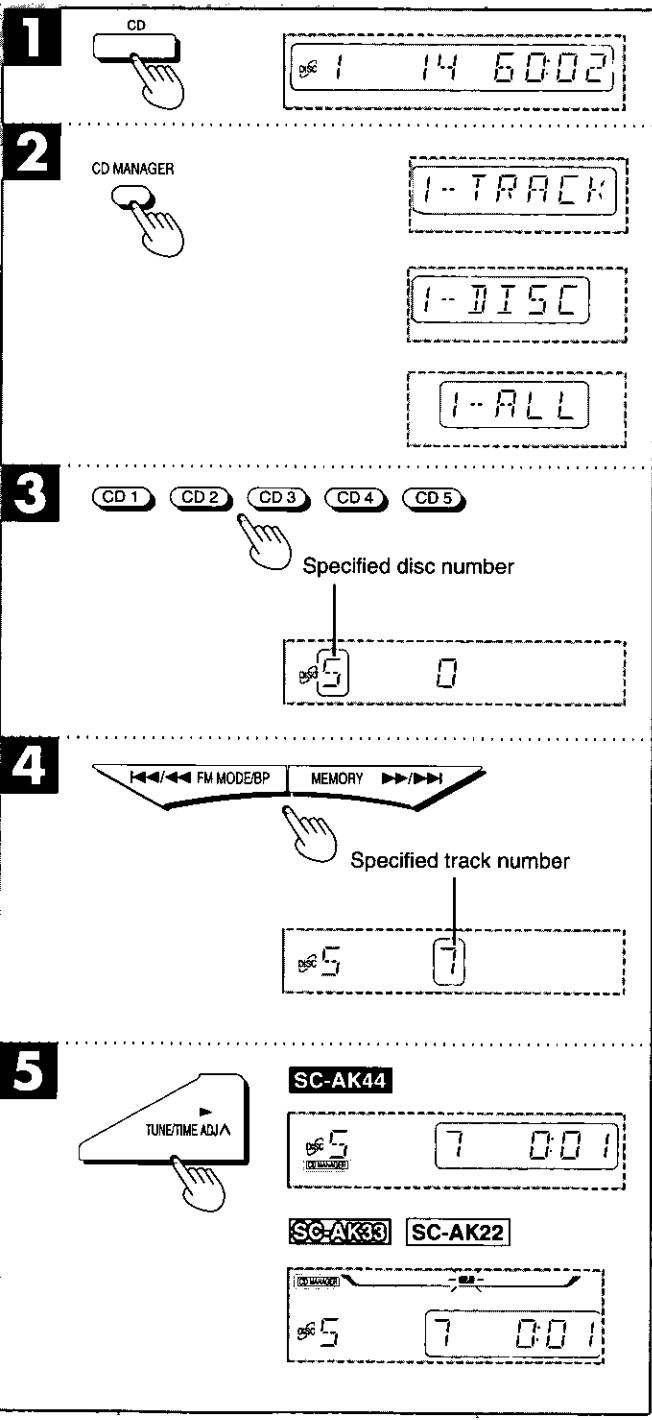
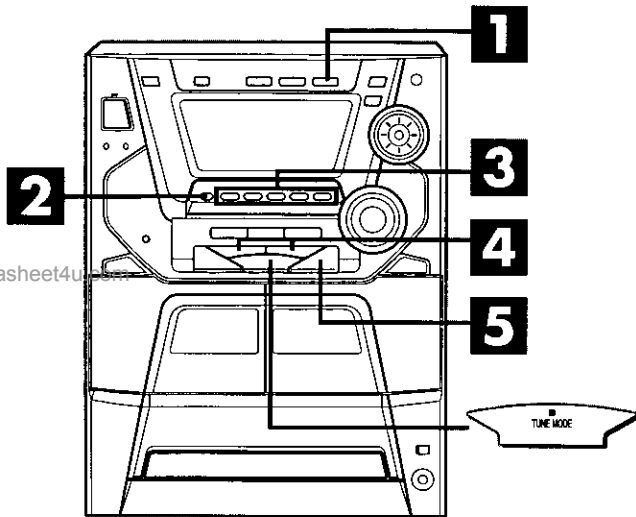

## Listening to compact discs

### To listen to special CDs and tracks (CD Manager function)

This function makes it easier for you to select special CDs and tracks from amongst those loaded in the player.

You can use this function to make recordings as well.

There are 3 CD/track selection modes.

- For playing back 1 track only from all loaded CDs  
1-Track mode (1-TRACK)
- For playing back 1 CD only from all loaded CDs  
1-Disc mode (1-DISC)
- For playing back 1 track on all loaded CDs  
1-Track All-Disc mode (1-ALL)

- 1 Press [CD].**  
Ensure CD is stopped.
- 2 Press [CD MANAGER] to select the desired mode.**  
Every time you press the button:  
1-TRACK → 1-DISC → 1-ALL  
← NORMAL (OFF) →  
  
1-TRACK: Only one particular track is played.  
1-DISC: The tracks on only one particular disc are played.  
1-ALL: The same track numbers on each of the CDs are played in succession.  
(NORMAL: The original display is restored in about 3 seconds.)
- 3 Press [(CD 1) ~ (CD 5)] to select the disc you want.**  
**Note**  
This step is not required if 1-ALL was selected in step 2.
- 4 Press [◀◀/▶▶] or [▶▶▶▶] to select the desired track.**  
**Note**  
This step is not required if 1-DISC was selected in step 2.
- 5 Press [▶].**  
The selected track will start.

#### To stop play

Press [■].

#### When playback ends

"NORMAL" will appear on the display for about 3 seconds, then the CD MANAGER function will turn OFF automatically.

#### During play in the 1-ALL mode:

- It is not possible to skip back to a CD whose track has already been played.
- If a CD does not have the designated track number, it is skipped and play continues.

#### Notes

- You can use the CD Manager function together with repeat play.
- CD Manager function will be canceled when you press the [RANDOM] button.

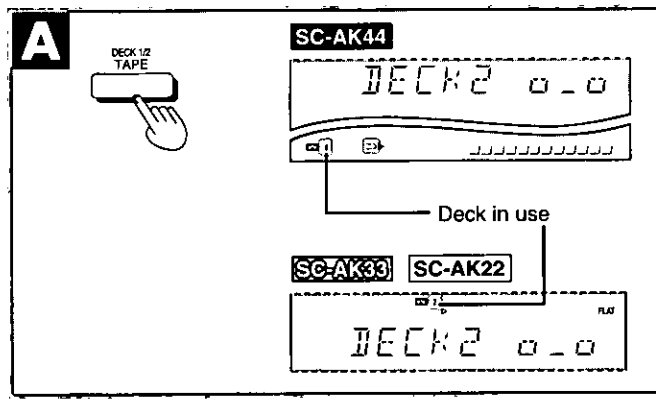
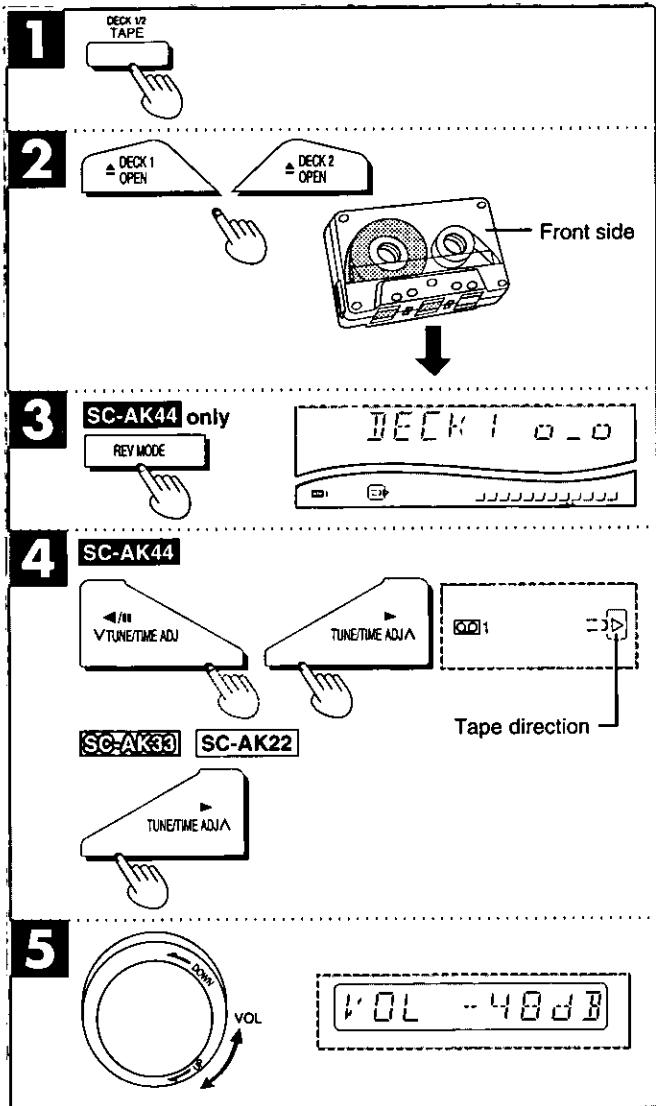
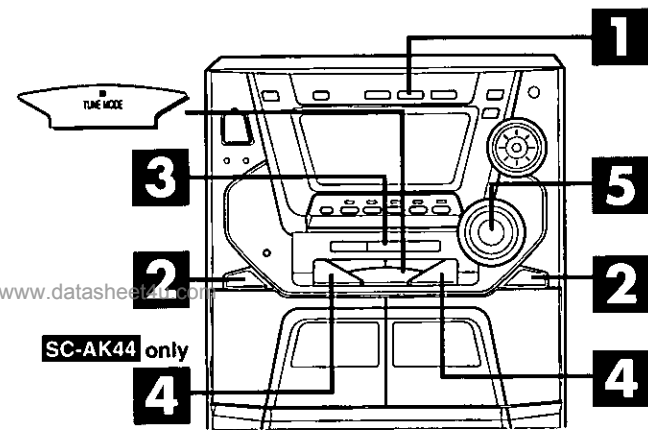

## Listening to tapes

You can use either deck 1 or deck 2 for tape playback.

### SC-AK44

The unit can play normal, high and metal position tapes. It identifies the type automatically.

### SC-AK33 SC-AK22

Use normal position tapes.

High position and metal position tapes can be played, but the unit will not be able to do full justice to the characteristics of these tapes.

### 1 Press [TAPE, DECK 1/2].

The unit will come on automatically.

If the unit was off and a cassette was loaded, play will start automatically (One touch play function).

### 2 Press [▲ DECK 1 OPEN] or [▲ DECK 2 OPEN] and insert the tape.

Insert the tape with the exposed tape facing down. Close the holder by hand.

### 3 SC-AK44 only

Press [REV MODE] to select the reverse mode.

Every time you press the button:

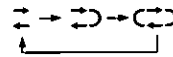

→ : One side is played.

↔ : Both sides are played.

↻ : Both sides are played 8 times each.

To listen to 2 tapes consecutively

Load a tape into each deck and select "↻". Both tapes will be played 8 times each.

### 4 SC-AK44

Press [◀/II] or [▶] to start playback.

[▶] : The forward side (front side) will play.

[◀/II] : The reverse side will play.

### SC-AK33 SC-AK22

Press [▶] to start playback.

One side is played, then playback stops automatically.

To play on the other side of the tape, turn the tape over and press [▶].

### 5 Adjust the volume.

To stop tape playback

Press [■].

### A To change the deck to be used

Press [TAPE, DECK 1/2] to select the deck you want to use when you load cassettes into both decks.

### Notes

- Playback is momentarily interrupted while playing back tapes, if you open the other deck.
- Tapes exceeding 100 minutes are thin and can break or get caught in the mechanism.
- Tape slack can get caught up in the mechanism and should be taken up before the tape is played.

### SC-AK44

Endless tapes can get caught up in the deck's moving parts if used incorrectly. Use tapes appropriate to this unit's auto-reverse mechanism.

### SC-AK33 SC-AK22

Failure to operate these tapes correctly may cause the tape to wind around the revolving parts. Always read the instructions provided with your tapes.

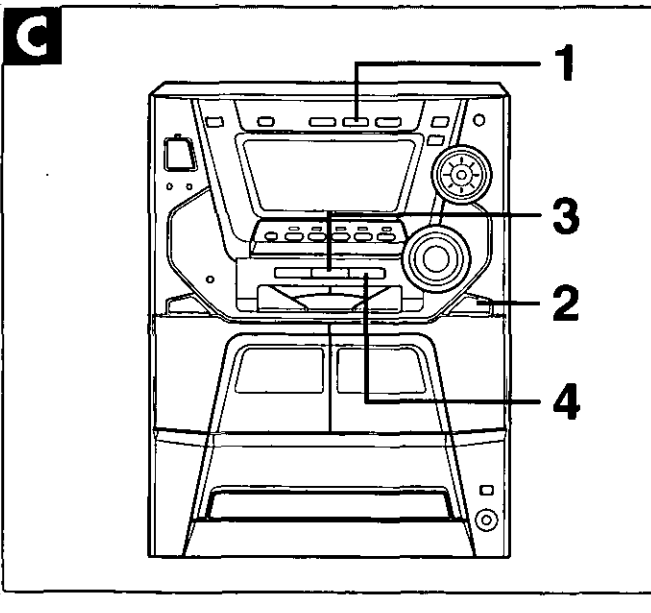
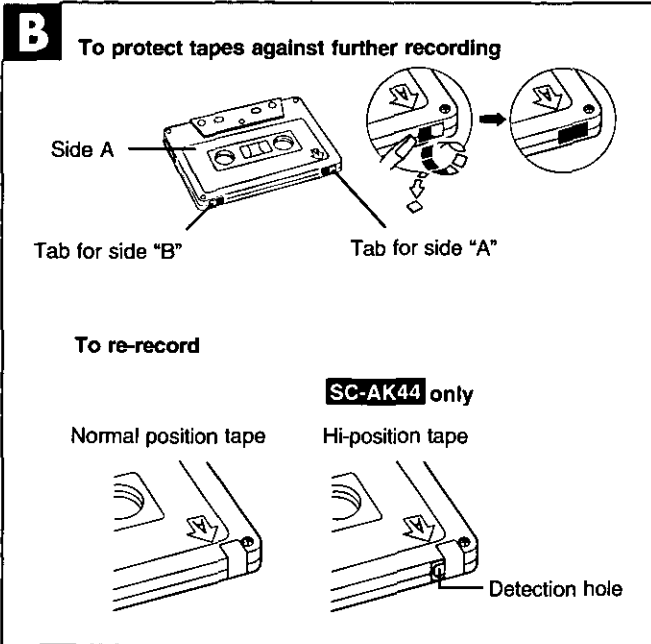
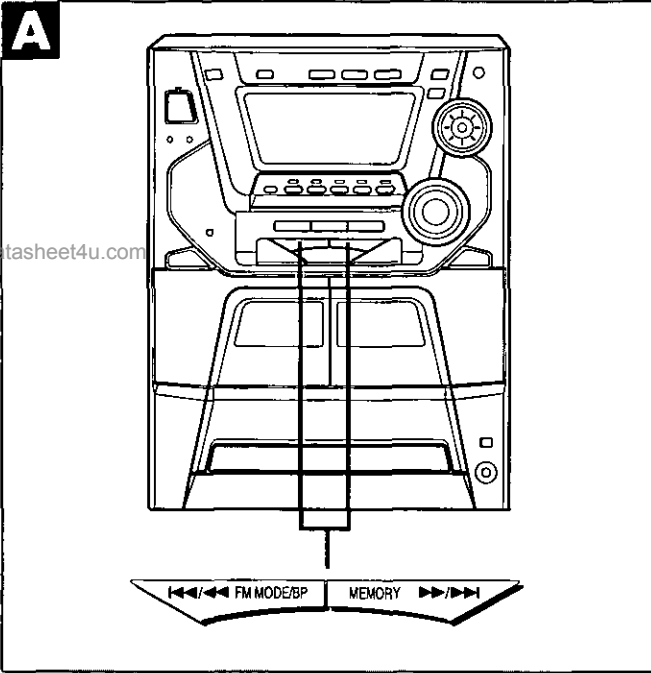

**Listening to tapes**

**A To fast-forward or rewind the tape**

Press [**◀◀/◀◀**] or [**▶▶/▶▶**] in the stop mode.

**SC-AK44**

Tape direction	To rewind	To fast-forward
"▶"	[ <b>◀◀/◀◀</b> ]	[ <b>▶▶/▶▶</b> ]
"◀"	[ <b>▶▶/▶▶</b> ]	[ <b>◀◀/◀◀</b> ]

**SC-AK33 SC-AK22**

To rewind	To fast-forward
[ <b>◀◀/◀◀</b> ]	[ <b>▶▶/▶▶</b> ]

**A To find the beginning of a program (TPS: Tape Program Sensor)**

TPS finds the beginning of a track and resumes play from there. Each press increases the number of tracks skipped, up to a maximum of 9.

Press [**◀◀/◀◀**] or [**▶▶/▶▶**] during play.

**Note**

- TPS may not operate correctly in the following situations:  
 If the interval between tracks is less than 4 seconds.  
 If there is noise between tracks.  
 If there are silent parts within tracks.

**Before recording (Deck 2 only)**

**Types of tapes which can be recorded correctly**

**SC-AK44**

Use normal and high position tapes. Metal position tapes can be used, but the unit will not be able to record or erase them correctly. The unit automatically identifies the type of tape.

**SC-AK33 SC-AK22**

Use normal position tapes. High position and metal position tapes can be used, but this unit will not be able to record or erase them correctly.

**B Erasure prevention**

The illustration shows how to remove the tabs to prevent recording. To record on the tape again, cover as shown, being careful not to cover the high position discrimination hole.

**How volume, sound quality/field affect recording**

The tape you are recording is not affected whatsoever by changes in volume, sound quality/field.

**C To erase a recorded sound**

1. Press [TAPE, DECK 1/2].
2. Insert the recorded tape into deck 2.
3. **SC-AK44** only  
Press [REV MODE] to select reverse mode.
4. Press [● REC/STOP].

**Notes**

- You cannot open deck 1 while recording.
- You cannot fast-forward or rewind one deck while recording with the other.

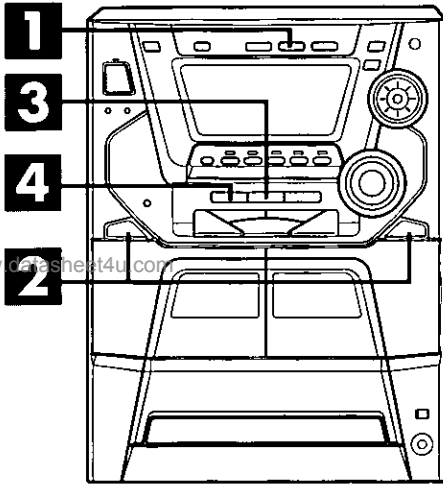

## Tape-to-tape recording

The recording level will be recorded as it is on the tape being played back.

**1** Press [TAPE, DECK 1/2].

**2** Press [▲ OPEN] on both decks and insert the tapes.  
 For playback: Into deck 1  
 For recording: Into deck 2  
 Close the holders by hand.

**3** **SC-AK44** only

Press [REV MODE] to select the reverse mode.

Every time you press the button:

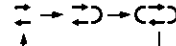

→ : One side records only.

↔ : Both sides record (front → reverse).

“↔” automatically changes to “→” when [TAPE EDIT] is pressed.

**4** Press [TAPE EDIT] to start recording.

### To stop recording

Press [■].

Both decks will stop.

### To record from a specific point on a tape

Before recording, advance the tape to the point from where you want to start recording.

### SC-AK44

#### To start recording on the reverse side

Load a tape and change the tape direction as follows:

1. Press [TAPE, DECK 1/2] and select tape deck 2.
2. Press [◀] and immediately thereafter [■]. The tape direction will be shown as “◀”.

### SC-AK33 SC-AK22

#### To record on the other side of the tape

Turn the tape over and press [TAPE EDIT].

**1** DECK 1/2 TAPE

**2** DECK 1 OPEN DECK 2 OPEN

**3** **SC-AK44** only  
REV MODE

**4** TAPE EDIT

**SC-AK44**  
DECK 2 0-0

**SC-AK33 SC-AK22**  
DECK 2 0-0

**SC-AK44**  
DECK 2 0-0

Tape direction of the tape you are recording onto

**SC-AK33 SC-AK22**  
DECK 1 - - 1 2

## Recording from radio broadcasts

Wind up the leader tape so recording can begin immediately.

**1** Press [**DECK 2 OPEN**] and insert the tape.  
Close the holder by hand.

**2** **SC-AK44** only  
Press [**REV MODE**] to select the reverse mode.  
Every time you press the button:

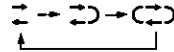

← : One side, only, records.

↔, ↔ : Both sides record (front side → reverse side).

↔ " automatically changes to "↔" when [**REC/STOP**] is pressed.

**3** Select a radio station. Perform steps **1** through **3** on page 12.

**4** Press [**REC/STOP**] to start recording.

### To stop recording

Press [**REC/STOP**] again.

Recording can also be stopped by pressing [**■**].

### To record from a specific point on a tape

Before recording, advance the tape to the point from where you want to start recording.

### To cut an unnecessary part while recording

1. Press [**REC/STOP**] during the unnecessary part. The cassette deck will go into the stop mode.
2. Press [**REC/STOP**] to resume recording again. Recording will continue in the same direction as before.

### SC-AK44

#### To start recording on the reverse side

Load a tape and change the tape direction as follows:

1. Press [**TAPE, DECK 1/2**] and select tape deck 2.
2. Press [**◀/||**] and immediately thereafter [**■**]. The tape direction will be shown as "<".

### SC-AK33 SC-AK22

#### To record on the other side of the tape

Turn the tape over and press [**REC/STOP**].

### Note

When recording an AM broadcast, sound is momentarily interrupted when you start and stop the recording.

### A To reduce noise while AM recording (Beat proof function)

Press [**◀◀/▶▶, FM MODE/BP**] while recording.

Each time you press the button, "BP1" and "BP2" will be displayed alternately.

Select the position where there is less noise.

www.datasheet4u.com

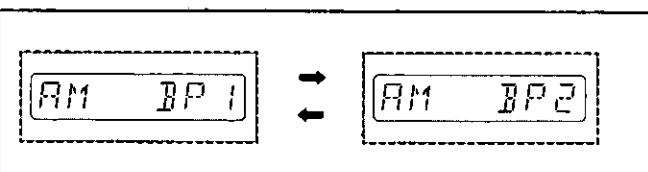
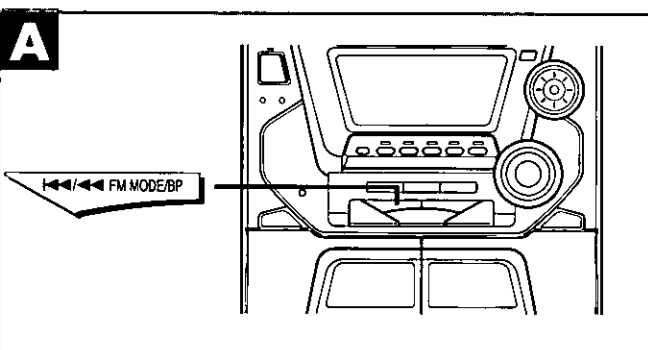
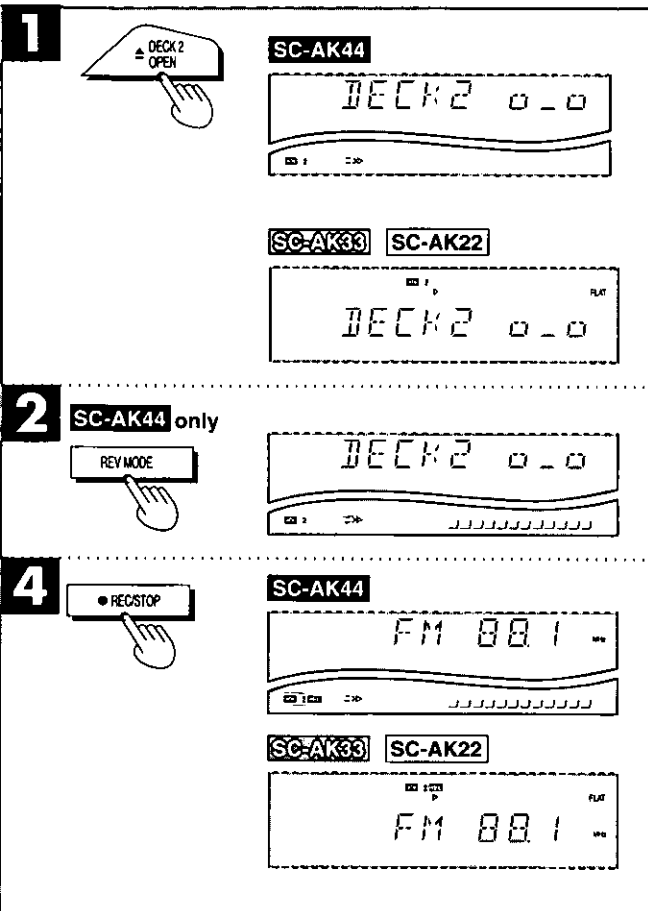
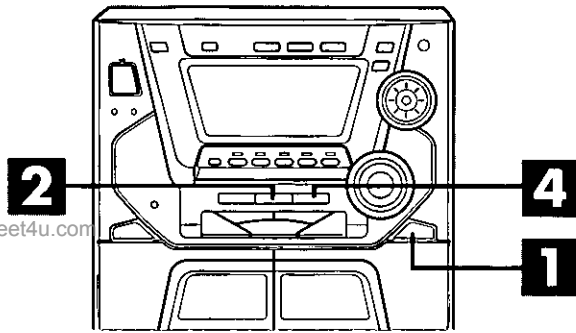

## Recording from compact discs

Wind up the leader tape so recording can begin immediately.

**1** Press [▲ DECK 2 OPEN], and insert the tape. Close the holder by hand.

**2** **SC-AK44** only  
Press [REV MODE] to select the reverse mode. Every time you press the button:

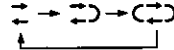

→ : One side only records.

↔, ⇄ : Both sides (front → reverse) record.

“⇄” automatically changes to “↔” when [● REC/STOP] is pressed.

**3** Press [CD].

**4** Insert CD in the tray.  
(Perform steps **1** ~ **2** on page 15).

**5** Press [(CD 1) ~ (CD 5)] to select the disc you want. Pressing [■] will stop playback.

**6** Press [● REC/STOP] to start recording.

- The recording will proceed from the first track on the selected CD and will continue on through the last track of the final disc (page 15).
- The tape deck stops automatically when the CD is finished.

### To stop recording

- To add a 4 second silent interval before stopping Press [■]. The CD will stop automatically too.
- To stop recording without a silent interval Press [● REC/STOP]. The CD will stop automatically too.

### To record programmed tracks

1. After step **4**, program the track you want (perform steps **2** ~ **6** on page 17).
2. Press [● REC/STOP] to start recording.

### SC-AK44

#### To start recording on the reverse side

Load a tape and change the tape direction as follows:

1. Press [TAPE, DECK 1/2] and select tape deck 2.
2. Press [◀/||] and immediately thereafter [■]. The tape direction will be shown as “<”.

### SC-AK33 SC-AK22

#### To record on the other side of the tape

Turn the tape over and press [● REC/STOP].

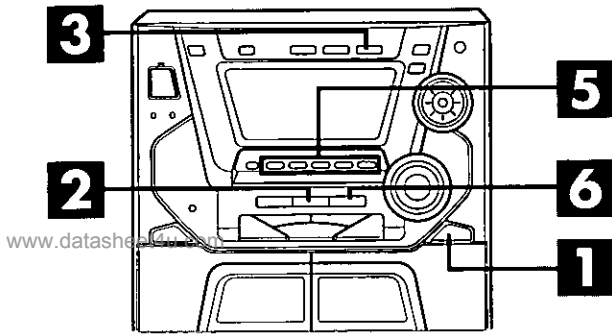

**1** **SC-AK44**

**SC-AK33 SC-AK22**

**2** **SC-AK44** only

**3** CD

↓

**5** ① (CD 1) (CD 2) (CD 3) (CD 4) (CD 5)

↓

② TUNE MODE

**6** ● REC/STOP

**SC-AK44**

**SC-AK33 SC-AK22**

www.datasheet4u.com

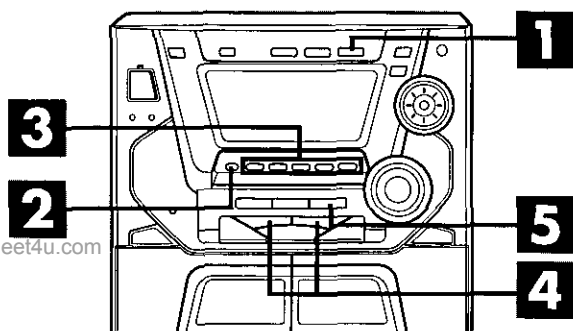

**1**

CD 1 14 60:02

**2**

CD MANAGER

1-TRACK

1-DISC

1-ALL

**3**

CD 1 CD 2 CD 3 CD 4 CD 5

1 0

**4**

FM MODE/BP MEMORY

3 6

**5**

REC/STOP

SC-AK44

5 1 0:01

SC-AK33 SC-AK22

5 1 0:01

**A**

Front side	1	2	3	4	5
Reverse side	9	8	7	6	5

The interrupted track is re-recorded in its entirety on the reverse side.

## Recording from compact discs

### To record special CDs and tracks (CD Manager function)

This function makes it easier for you to select special CDs and tracks from amongst those loaded in the player.

#### Preparation

Press [▲DECK 2 OPEN] and insert the tape. Wind up the leader tape so recording can begin immediately.

**1** Press [CD].

**2** Press [CD MANAGER] to select the desired mode. Every time you press the button:

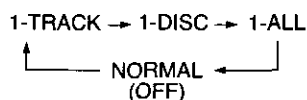

1-TRACK: Only one particular track is recorded.

1-DISC: The tracks on only one particular disc are recorded.

1-ALL: The same track numbers on each of the CDs are recorded in succession.

(NORMAL: The original display is restored in about 3 seconds.)

**3** Press [(CD 1) ~ (CD 5)] to select the disc you want.

#### Note

This step is not required if 1-ALL was selected in step 2.

**4** Press [◀◀/▶▶] or [▶▶/▶▶] to select the desired track.

#### Note

This step is not required if 1-DISC was selected in step 2.

**5** Press [● REC/STOP] to start recording.

#### To stop recording

- To add a 4 second silent interval before stopping Press [■]. The CD will stop automatically too.
- To stop recording without a silent interval Press [● REC/STOP]. The CD will stop automatically too.

#### SC-AK44

- A** While recording, if a track is cut off in the middle at the end of the front side, it is re-recorded from the beginning, on the reverse side.
- At the end of the reverse side recording stops and the current track will be interrupted.

#### SC-AK33 SC-AK22

#### If the tape finishes before the CD

The CD continues playing. Press [■] to stop it. (CD Manager function will also be canceled.)



# A

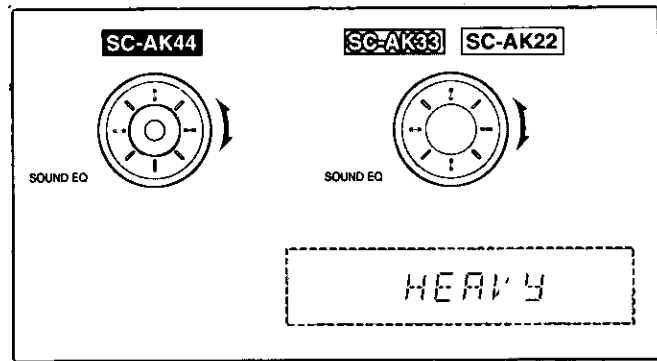
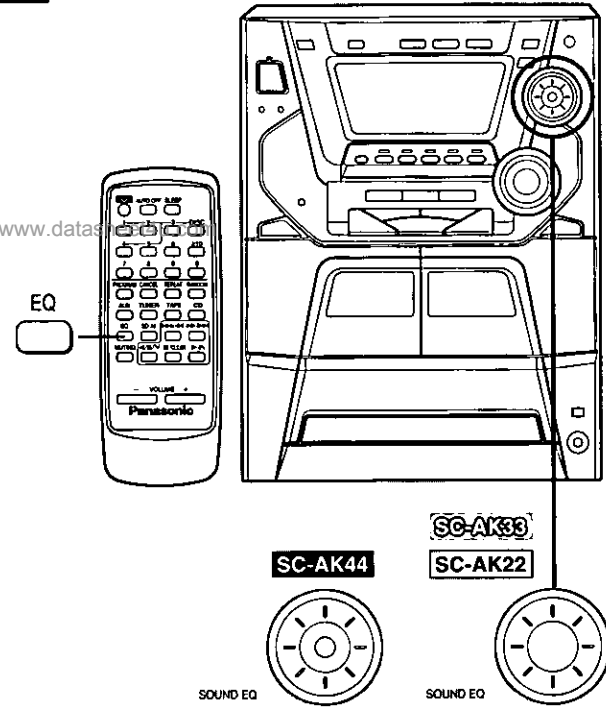

# B

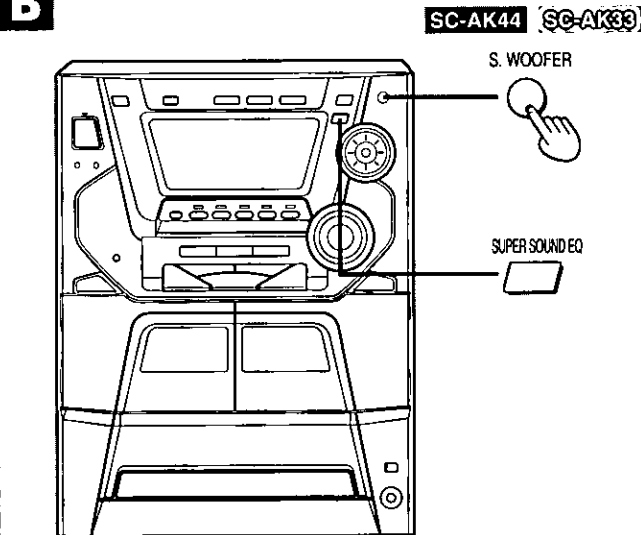

## A Using the built-in sound quality/sound field settings

**Dial [SOUND EQ]** to select the sound quality or sound field. When it is turned clockwise, the settings are selected in the following sequence.

- ① **HEAVY (sound quality)**  
Select this when playing rock or other kinds of music that sound better with an added punch.
- ② **CLEAR (sound quality)**  
Select this for jazz or other kinds of music for which clarity in the treble range is desired.
- ③ **SOFT (sound quality)**  
Select this when listening to background music.
- ④ **DISCO (sound field)**  
Select this to produce sound with the same kind of lengthy reverberations heard at a disco.
- ⑤ **LIVE (sound field)**  
Select this to make vocals more alive.
- ⑥ **HALL (sound field)**  
Select this to add an expansiveness to the sound to produce the atmosphere of a great concert hall.
- ⑦ **SC-AK44 only**  
**MANUAL** (see page 26)
- ⑧ **SC-AK44 only**  
**AI-EQ** (see page 26)

The original display is restored on the display panel in about 5 seconds.

**To release the equalizer**

Dial [SOUND EQ] to display "FLAT".

**When using the remote control to perform the operations described above**

Press [EQ].

Each time this button is pressed, the setting is changed in the sequence described above.

### Note

All recordings are performed at the flat setting even if an alternative sound quality/sound field setting has been selected.

## B Enhancing the sound quality

This feature enhances the bass and treble effect of the sound.

**Press [SUPER SOUND EQ].**

Press the button again to cancel.

The button light goes out.

## B Boosting the super woofer

**SC-AK44 and SC-AK33 only**

**Press [S.WOOFER].**

- When listening to the sound through the speakers  
MID (medium) → MAX (high) → Light off (OFF)



- When listening to the sound through the headphones

Light on (ON) = Light off (OFF)

### Note

You cannot record super woofer effect, but you can use it for playback sound.

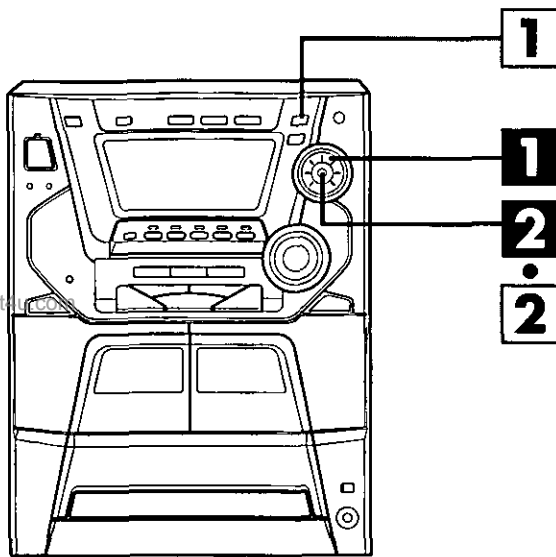

**1**

**2**

①

②

**1**

**2**

①

②

## Varying the sound quality with the manual equalizer

**SC-AK44** only

**1** Dial [SOUND EQ] to display "MANUAL".  
When it is turned clockwise, the settings are selected in the following sequence.

- ① HEAVY
- ② CLEAR
- ③ SOFT
- ④ DISCO
- ⑤ LIVE
- ⑥ HALL
- ⑦ **MANUAL**
- ⑧ AI-EQ
- ⑨ FLAT

**2** Adjust the sound quality.

① ← → direction: For selecting the range of the sound to be adjusted

**Characteristics of each sound range**

- Under 100 Hz: Super woofer range
- Around 330 Hz: Bass to midrange
- Around 1 kHz: Midrange
- Around 3.3 kHz: Midrange to treble
- Above 10 kHz: Treble

② ↓ ↑ direction: For adjusting the level (7 steps)

When the level is in the center, the dot flashes rapidly.

Repeat steps ① and ② to set the desired sound quality.

The original display is restored on the display panel in about 5 seconds.

**To release the equalizer**

Dial [SOUND EQ] to display "FLAT".

**Notes**

- The sound quality setting is stored automatically. It is recalled when "MANUAL" is next selected.
- All recordings are performed at the flat setting even if an alternative sound quality setting has been selected.

## Varying the sound quality with the acoustic image (AI) equalizer

**SC-AK44** only

The AI equalizer uses the SOFT, SHARP, HEAVY and LIGHT sound quality coordinates to achieve subtle sound quality settings with ease.

**1** Press [3D AI] to adjust the surround level.

Every time you press the button:

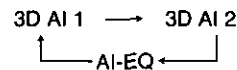

**2** Adjust the sound quality.

① ← → direction: SOFT-SHARP setting

② ↓ ↑ direction: LIGHT-HEAVY setting

Repeat steps ① and ② to set the desired sound quality.

The original display is restored on the display panel in about 5 seconds.

**To release the equalizer**

Dial [SOUND EQ] to display "FLAT".

**Notes**

- The sound quality setting is stored automatically. It is recalled when "AI-EQ" is next selected.
- All recordings are performed at the flat setting even if an alternative sound quality setting has been selected.

## Using the timer

### Using the play/record timer

The timer has two functions. It can be set to on at a certain time to wake you up, or it can be set to record the radio or from the aux source.

The play timer cannot be used in combination with the record timer.

#### Preparations

- Turn the unit on and set the clock (→ page 11).
- For the **play timer**, prepare the music source you want to listen to; tape, CD, radio or aux, and set the volume.
- For the **record timer**, check the cassette's erasure prevention tabs (→ page 20: **E**), insert the tape in deck 2, select the reverse mode (for SC-AK44) (→ page 22) and tune to the radio station (→ page 12) or select the aux source (→ page 29).

#### 1 Press [CLOCK/TIMER] to select the timer function.

Every time you press the button:

CLOCK → **⊖**PLAY → **⊖**REC

↑ Previous display ↓

**⊖**PLAY : to set the play timer

**⊖**REC : to set the record timer

#### Setting the start and finish times

- #### 2
- ① (Within 8 seconds or so)  
Press [TUNE/TIME ADJ (V) or (^)] to select the starting time.
  - ② Press [CLOCK/TIMER].

- #### 3
- ① Press [TUNE/TIME ADJ (V) or (^)] to select the finishing time.
  - ② Press [CLOCK/TIMER].

The start and finish times are now set.

#### Turning the timer on

- #### 4
- Press [**⊖**PLAY/**⊖**REC] to display the timer indicator.

Every time you press the button:

**⊖**PLAY → **⊖**REC

↑ (OFF) ↓

**⊖**PLAY : to turn the play timer on

**⊖**REC : to turn the record timer on

(The indicator doesn't appear if the start and finish times or the clock haven't been set.)

- #### 5
- Press [**⊖**/I, POWER] to turn the unit off.

The unit must be off for the timers to operate.

- For **play timer**  
The timer play will start at the preset time with volume increasing gradually up to the volume level you preset.
- For **record timer**  
The record timer comes on about 30 seconds earlier than the set time.

#### To cancel the timer

Press [**⊖**PLAY/**⊖**REC] to clear the timer indicators from the display. (The timer comes on at the set time everyday if the timer is on.)

#### To change the settings (when unit is on)

- To change the play/record times  
Do steps **1**, **2**, **3** and **5**.
- To change the source or volume
  1. Press [**⊖**PLAY/**⊖**REC] to clear the timer indicator from the display.
  2. Make changes to the source or volume.
  3. Do steps **4** to **5**.

(Continued on next page)

www.datasheet4u.com

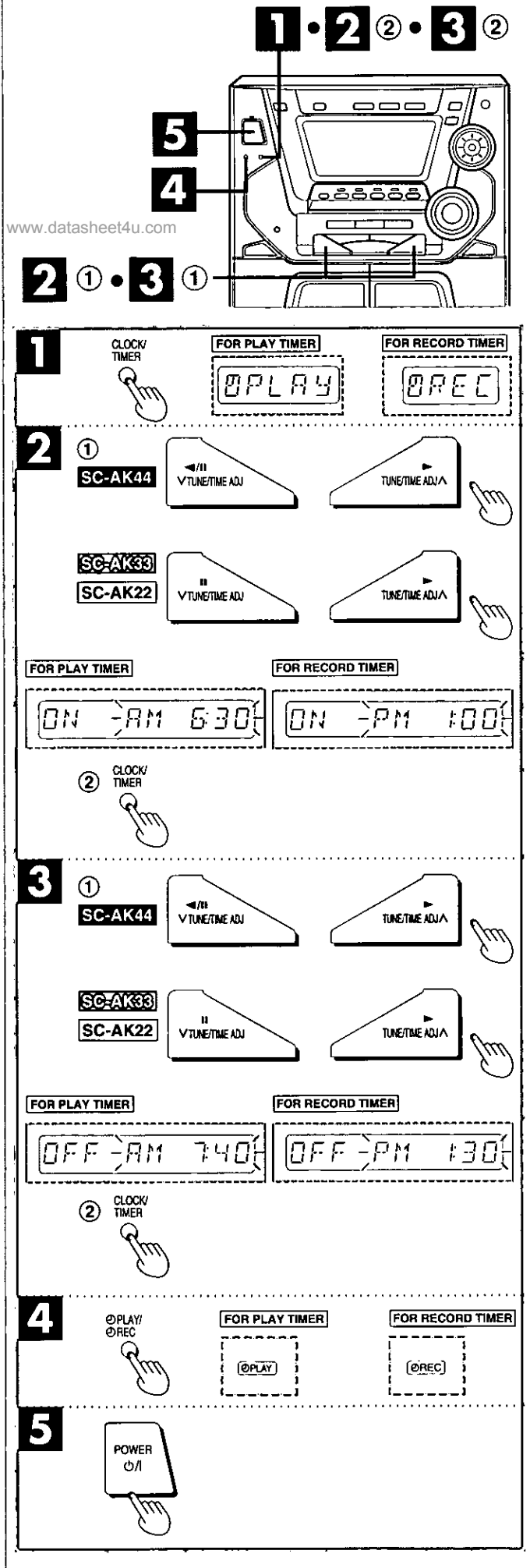

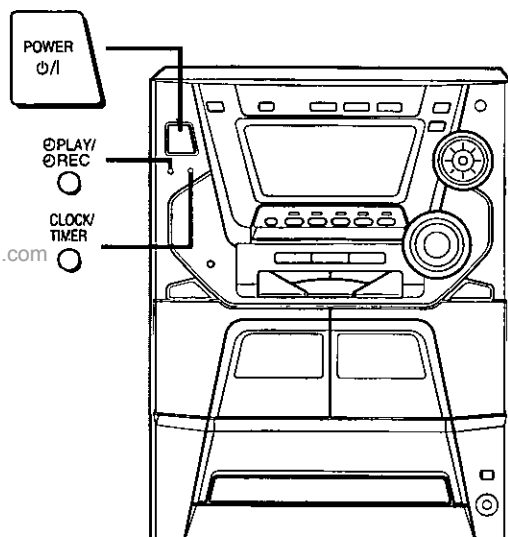

## Using the timer

### Using the play/record timer

#### To change the timer

Press [PLAY/REC] to select the desired timer.

Every time the button is pressed the setting changes as follows.

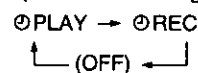

#### To check settings

While the unit is on and the "PLAY" (or "REC") indicator is on, press [CLOCK/TIMER] so "PLAY" (or "REC") appears on the display.

Two seconds after "PLAY" (or "REC") appear, the settings are displayed in the following order:

- |                    |                         |
|--------------------|-------------------------|
| • For play timer   | • For record timer      |
| ① Play start time  | ① Recording start time  |
| ② Play finish time | ② Recording finish time |
| ③ Play source      | ③ Recording source      |
| ④ Playback volume  |                         |

You can check the settings even when the system is OFF by pressing [CLOCK/TIMER] twice.

#### To enjoy the desired source after the timer setting is completed

The volume level (for play timer) and music source are stored in the timer memory and the timer will start in these preset conditions. However, the Disc numbers and reverse mode (for SC-AK44) do not get stored in the timer memory.

1. After step 4, start playing the desired source.
2. Reset the Disc numbers and reverse mode (for SC-AK44) if you have changed any of them, confirm that a Disc or cassette is inserted, then press [PAUSE], [POWER] to put the unit on standby.

#### Notes

- If you switch the system to the standby mode while the play/record timer is functioning, the OFF time setting will not be activated.
- If AUX is selected as the source, when the timer comes ON, the system will turn ON and will engage "AUX" as the source. If you want to playback or record from a connected component, set the component's timer to the same time. (See the instruction manual that came with the component.)

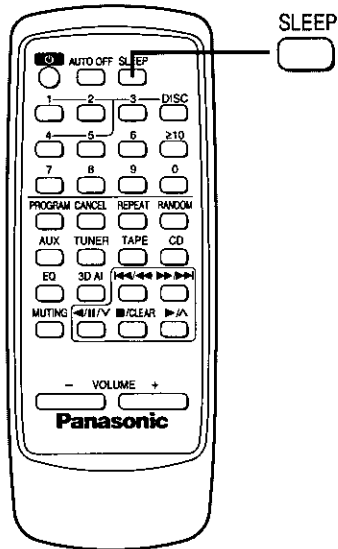
**A**

www.datasheet4u.com

## Using the timer

### A Using the sleep timer

#### by remote control only

This timer turns your system OFF at the set time (Max. 2 hours, settable at 30-minute intervals). It lets you fall asleep listening to music.

#### Preparation

Switch on the power.

The figure shows how to set the system to standby mode after 30 minutes.

While enjoying the desired source:

Press [SLEEP] to select the desired time.

Every time you press the button:

→ SLEEP 30 → SLEEP 60 → SLEEP 90 → SLEEP 120 → SLEEP OFF →

The system is turned off after the set time has elapsed.

#### To cancel the sleep timer:

Press [SLEEP] to select "SLEEP OFF".

#### To confirm the remaining time:

(only while system is ON)

Press [SLEEP].

#### To change the time remaining during operation:

Press [SLEEP] to show the remaining time then press [SLEEP] to select the desired time.

#### Notes

- The sleep timer turns OFF automatically the moment you attempt to edit-record a CD using CD Manager function.
- The sleep timer can be used in combination with the play/record timer.

The sleep timer always has priority.

Be sure not to overlap timer settings.

### B Using an external unit

#### Listening to an external source

(See page 7 for external unit connection)

1. Press [AUX].  
The system will come on automatically.
2. Start playback from the external source. (For details, refer to the owner's manual of the equipment.)

#### Recording from an external source

1. Press [AUX].
2. Press [● REC/STOP] (recording starts).
3. Start playback from the external source. (For details, refer to the owner's manual of the equipment.)

### C Listening with headphones

Reduce the volume level, and connect the headphones.

Plug type: 3.5 mm (1/8") stereo

#### Note

Avoid listening for prolonged periods of time to prevent hearing damage.

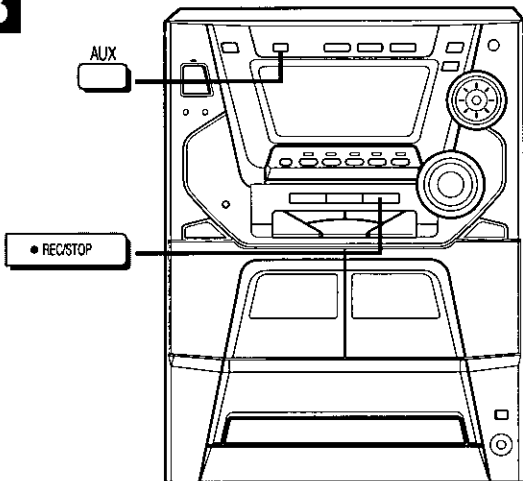
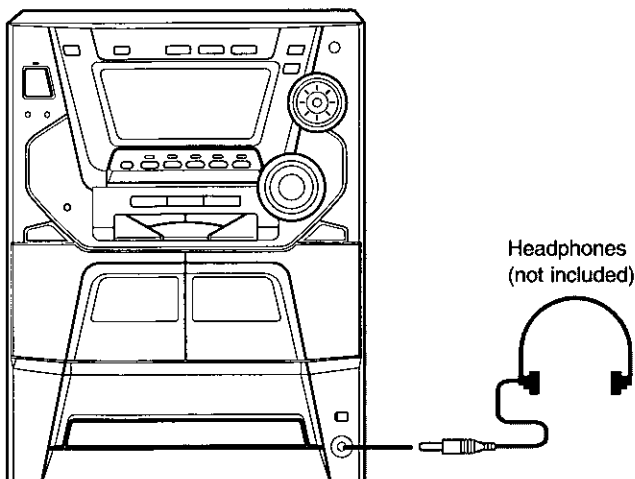
**B****C**

## Troubleshooting guide

Before requesting service, make the checks below. If you can't fix the system as described below, or if something not listed here occurs, refer to the enclosed directory to locate an Authorized Service Center convenient to you or contact your dealer.

For detailed instructions, contact an authorized servicenter in the U.S.A. and Panasonic Canada Inc. Customer Care Centre in Canada. In the U.S.A., call 1-800-211-7262, e-mail [consumerproducts@panasonic.com](mailto:consumerproducts@panasonic.com), or visit [www.panasonic.com](http://www.panasonic.com). In Canada, call 905-624-5505 or visit [www.panasonic.ca](http://www.panasonic.ca)

Reference pages are shown as black circled numbers ⑥.

### Common Problems

<p><b>No sound.</b></p> <p><b>Sound is unfixd, reversed or comes from one speaker only.</b></p> <p><b>Humming heard during play.</b></p> <p><b>"ERROR" is displayed.</b></p> <p><b>"- - -" appears on the display.</b></p> <p><b>"F61" is displayed.</b></p>	<p>Turn the volume up.</p> <p>The speaker cables may be shorted. Turn the unit off, check and correct the connections and turn the unit on. ⑥</p> <p>Check the speaker connections. ⑥</p> <p>An AC power supply cord or fluorescent light is near the cables. Keep other appliances and cords away from this unit's cables.</p> <p>Incorrect operation performed. Read the instructions and try again.</p> <p>You plugged the power supply cord in for the first time or there was a power failure recently. Set the time. ①</p> <p>Check and correct the speaker cords connection. ⑥</p> <p>If this does not fix the problem, there is a power supply problem. Consult the dealer.</p>
--	---

### Listening to the radio

<p><b>Noise is heard.</b></p> <p><b>The stereo indicator flickers or doesn't light.</b></p> <p><b>Sound is distorted.</b></p> <p><b>A beat sound is heard.</b></p> <p><b>A low hum is heard during AM broadcasts.</b></p>	<p>Use an outdoor antenna. ⑦</p> <p>Turn the TV off or separate it from the unit.</p> <p>Separate the antenna from other cables and cords.</p>
---	--

### When there is a television set nearby

<p><b>The picture on the TV disappears or stripes appear on the screen.</b></p>	<p>The location and orientation of the antenna are incorrect. If you are using an indoor antenna, change to an outdoor antenna.</p> <p>The TV antenna wire is too close to the unit. Separate the antenna wire of the TV set from the unit.</p>
---	---

### Using the cassette deck

<p><b>Poor quality sound.</b></p> <p><b>Recording is not possible.</b></p>	<p>Clean the heads. ⑩</p> <p>If the erasure prevention tabs have been removed, cover the holes with adhesive tape. ⑭</p>
--	--

### Playing discs

<p><b>The display is wrong or play won't start.</b></p> <p><b>"TAKE OUT/DISC" appears on the display.</b></p>	<p>The disc may be upside down. ⑮</p> <p>Wipe the disc.</p> <p>Replace the disc if it is scratched, warped, or non-standard.</p> <p>Condensation may have formed inside the unit due to a sudden change in temperature. Wait about an hour for it to clear and try again.</p> <p>There is a problem with the disc mechanism. (A power failure may have occurred.)</p> <p>The tray will open automatically. Remove the disc from the tray, and after ensuring there is no disc in the tray, close it. The unit will make the disc changing noises for a few moments and then it should operate normally.</p>
---	---

### Remote control

<p><b>Remote control doesn't work.</b></p>	<p>Check the batteries are inserted correctly. ⑤</p> <p>Replace the batteries if they are worn.</p>
--	---

## Maintenance

### If the surfaces are dirty

To clean this unit, wipe with a soft, dry cloth. If the surfaces are extremely dirty, use a soft cloth dipped in a soap-and-water solution or a weak detergent solution.

- Never use alcohol, paint thinner or benzine to clean this unit.
- Before using a chemically treated cloth, carefully read the instructions that came with the cloth.

### For a cleaner, crisper sound

Clean the heads regularly to assure good quality playback and recording. Use a cleaning tape (not included).

**Panasonic**

**Technics**

**Quasar**

*For Product Information, Operating Assistance, Literature Request, Dealer Locations, and all Customer Service inquiries please contact:*

*1-800-211-PANA (7262), Monday–Friday 9 am–9pm; Saturday–Sunday 9 am–7pm, EST.*

www.datasheet4u.com

*Web Site: <http://www.panasonic.com>  
You can purchase parts, accessories or locate your nearest servicenter by visiting our Web Site.*

**Accessory Purchases:**

1-800-332-5368 (Customer Orders Only)

Panasonic Services Company 20421 84th Avenue South, Kent, WA 98032

(6 am to 5 pm Monday–Friday; 6 am to 10:30 am Saturday; PST)

(Visa, MasterCard, Discover Card, American Express, Check)

**Factory Servicenters Locations**

<p><b>CALIFORNIA</b> 6550 Katella Avenue Cypress, CA 90630</p> <p>800 Dubuque Avenue S. San Francisco CA 94080</p> <p>20201 Sherman Way Suite 102 Canoga Park, CA 91306</p> <p>3878 Ruffin Road Suite A San Diego, CA 92123</p> <p><b>COLORADO</b> 1640 South Abilene Street Suite D Aurora, CO 80012</p> <p><b>FLORIDA</b> 3700 North 29<sup>th</sup> Avenue Suite 102 Hollywood, FL 33020</p>	<p><b>GEORGIA</b> 8655 Roswell Road Suite 100 Atlanta, GA 30350</p> <p><b>ILLINOIS</b> 9060 Golf Road Niles, IL 60714</p> <p>1703 North Randall Road Elgin, IL 60123 (Pick-up/Drop-off only)</p> <p><b>MARYLAND</b> 62 Mountain Road Glen Burnie, MD 21061</p> <p><b>MASSACHUSETTS</b> 60 Glacier Drive Suite G Westwood, MA 02090</p>	<p><b>MICHIGAN</b> 37048 Van Dyke Avenue Sterling Heights, MI 48312</p> <p><b>MINNESOTA</b> 7850-12<sup>th</sup> Avenue South Airport Business Center Bloomington, MN 55425</p> <p><b>OHIO</b> 2236 Waycross Road Civic Center Plaza Forest Park, OH 45240</p> <p><b>PENNSYLVANIA</b> 2221 Cabot Blvd. West Suite B Langhorne, PA 19047</p>	<p><b>TEXAS</b> 13615 Welch Road Suite 101 Farmers Branch TX 75244</p> <p><b>WASHINGTON</b> 20425-84<sup>th</sup> Avenue South Kent, WA 98032</p> <p><b>HAWAII</b> 99-859 Iwaiwa Street Aiea, Hawaii 96701 Phone (808) 488-1996 Fax (808) 486-4369</p>
---	--	---	--

**Service in Puerto Rico**

*Matsushita Electric of Puerto Rico, Inc. Panasonic Sales Company/Factory Servicenter:  
Ave. 65 de Infanteria, Km. 9.5, San Gabriel Industrial Park, Carolina, Puerto Rico 00985  
Phone (787) 750-4300 Fax (787) 768-2910*

F04030 As of APR '00

Reference

# Specifications

## AMPLIFIER SECTION **SC-AK44**

**Power output**  
 10% Total harmonic distortion  
 70 Hz–120 Hz, both channels driven  
 (Low channel) 100 W per channel (6 Ω)  
 120 Hz–16 kHz, both channels driven  
 (High channel) 40 W per channel (6 Ω)  
**Total Bi-Amp power** 140 W per channel

**Power output**  
 10% Total harmonic distortion  
 80 Hz, both channels driven  
 (Low channel) 105 W per channel (6 Ω)  
 1 kHz, both channels driven  
 (High channel) 45 W per channel (6 Ω)  
**Total Bi-Amp power** 150 W per channel

**Input sensitivity**  
 AUX 250 mV

**Input Impedance**  
 AUX 13 kΩ

## AMPLIFIER SECTION **SC-AK33**

**Power output**  
 10% Total harmonic distortion  
 70 Hz–120 Hz, both channels driven  
 (Low channel) 85 W per channel (6 Ω)  
 120 Hz–16 kHz, both channels driven  
 (High channel) 35 W per channel (6 Ω)  
**Total Bi-Amp power** 120 W per channel

**Power output**  
 10% Total harmonic distortion  
 80 Hz, both channels driven  
 (Low channel) 90 W per channel (6 Ω)  
 1 kHz, both channels driven  
 (High channel) 40 W per channel (6 Ω)  
**Total Bi-Amp power** 130 W per channel

**Input sensitivity**  
 AUX 250 mV

**Input Impedance**  
 AUX 13 kΩ

## AMPLIFIER SECTION **SC-AK22**

**Power output**  
 10% Total harmonic distortion  
 70 Hz–16 kHz, both channels driven  
 60 W per channel (6 Ω)

**Power output**  
 10% Total harmonic distortion  
 1 kHz, both channels driven  
 70 W per channel (6 Ω)

**Input sensitivity**  
 AUX 250 mV

**Input Impedance**  
 AUX 13 kΩ

## FM TUNER SECTION

**Frequency range**  
 87.9 – 107.9 MHz (200 kHz steps)  
 87.5 – 108.0 MHz (100 kHz steps)

**Sensitivity**  
 2.5 μV (IHF)  
 S/N 26 dB 2.2 μV

**Antenna terminal(s)** 75 Ω (unbalanced)

## AM TUNER SECTION

**Frequency range**  
 520 – 1710 kHz (10 kHz steps)

**Sensitivity**  
 S/N 20 dB (at 1000 kHz) 560 μV/m

## CASSETTE DECK SECTION

**Track system** 4 track, 2 channel

**Heads**  
**Record/playback** Solid permalloy head  
**Erasure** Double gap ferrite head

**Motor** DC servo motor

**Recording system** AC bias 100 kHz

**Erasing system** AC erase 100 kHz

**Tape speed** 4.8 cm/s

**Frequency response**  
 (+3 dB, –6 dB at DECK OUT)  
**NORMAL (TYPE I)** 35 Hz – 14 kHz  
**(SC-AK44 only)**  
**HIGH (TYPE II)** 35 Hz – 14 kHz

**S/N** 50 dB (A weighted)

**Wow and flutter** 0.18% (WRMS)

**Fast forward and rewind time**  
 Approx. 120 seconds with  
 C-60 cassette tape

## CD SECTION

**Sampling frequency** 44.1 kHz

**Decoding** 16 bit linear

**Beam source/wavelength**  
 Semiconductor laser/780 nm

**Number of channels** Stereo

**Frequency response**  
 20 Hz–20 kHz (+1, –2 dB)

**Wow and flutter** Below measurable limit

**Digital filter** 8 fs

**D/A converter** MASH (1 bit DAC)

## SPEAKER SECTION **SB-AK44** **SB-AK33**

**Type** 3 way speaker system

**Speaker(s)**  
**Super Woofer** 17 cm (6<sup>3</sup>/<sub>4</sub>" cone type  
**Woofer** 12 cm (4<sup>3</sup>/<sub>4</sub>" cone type  
**Tweeter** 6 cm (2<sup>3</sup>/<sub>8</sub>" cone type

**Impedance**  
**HIGH** 6 Ω  
**LOW** 6 Ω

**Input power**  
**HIGH** 60 W (Music)  
**LOW** 140 W (Music)

**Output sound pressure level**  
 87 dB/W (1.0 m)

**Cross over frequency** 150 Hz, 5 kHz

**Frequency range** 45 Hz–22 kHz (–16 dB)  
 55 Hz–20 kHz (–10 dB)

**Dimensions (WxHxD)** 230 x 332 x 291 mm  
 (9<sup>1</sup>/<sub>16</sub>" x 13<sup>1</sup>/<sub>16</sub>" x 11<sup>15</sup>/<sub>32</sub>"

**Mass** 4.3 kg (9.5 lb)

## SPEAKER SECTION **SB-AK22**

**Type** 2 way speaker system

**Speaker(s)**  
**Woofer** 12 cm (4<sup>3</sup>/<sub>4</sub>" cone type  
**Tweeter** 6 cm (2<sup>3</sup>/<sub>8</sub>" cone type

**Impedance** 6 Ω

**Input power** 100 W (Music)

**Output sound pressure level**  
 85 dB/W (1.0 m)

**Cross over frequency** 5 kHz

**Frequency range** 45 Hz–22 kHz (–16 dB)  
 55 Hz–20 kHz (–10 dB)

**Dimensions (WxHxD)** 211 x 332 x 250 mm  
 (8<sup>5</sup>/<sub>16</sub>" x 13<sup>1</sup>/<sub>16</sub>" x 9<sup>27</sup>/<sub>32</sub>"

**Mass** 2.8 kg (6.2 lb)

## GENERAL

**Power supply** AC 120 V, 60 Hz

**Power consumption** (SC-AK44) 180 W  
 (SC-AK33) 165 W  
 (SC-AK22) 155 W

**Standby** 0.29 W

**Dimensions (WxHxD)** 250 x 332 x 316 mm  
 (9<sup>27</sup>/<sub>32</sub>" x 13<sup>1</sup>/<sub>16</sub>" x 12<sup>7</sup>/<sub>16</sub>"

**Mass** (SC-AK44) 8.5 kg (18.7 lb)  
 (SC-AK33) 8.3 kg (18.3 lb)  
 (SC-AK22) 7.6 kg (16.8 lb)

## Notes:

- Specifications are subject to change without notice.  
 Mass and dimensions are approximate.
- Total harmonic distortion is measured by the digital spectrum analyzer.
- (For SB-AK44 and SB-AK33)  
 The labels "HIGH" and "LOW" on the rear of the speakers refer to High frequency and Low frequency.

## Product Service

Do not attempt to remove the cover(s) or repair the unit yourself.  
 Refer servicing to qualified personnel only.

## Product information

For product service, product information or assistance with product operation, refer to the servicenter directory.

Panasonic Consumer Electronics  
 Company, Division of Matsushita  
 Electric Corporation of America  
 One Panasonic Way Secaucus,  
 New Jersey 07094  
<http://www.panasonic.com>

Panasonic Sales Company,  
 Division of Matsushita Electric of  
 Puerto Rico, Inc. ("PSC")  
 Ave. 65 de Infantería, Km. 9.5  
 San Gabriel Industrial Park, Carolina,  
 Puerto Rico 00985

Panasonic Canada Inc.  
 5770 Ambler Drive  
 Mississauga, Ontario  
 L4W 2T3  
[www.panasonic.ca](http://www.panasonic.ca)

